



Brief Operating Instructions

Active barrier 24 VDC

Active barrier, 1-/2-channel/SD for 4 to 20 mA, HART® transparent with 24 V_{DC} and active/passive input and output, optionally available with SIL and Ex

These Instructions are Brief Operating Instructions; they do not replace the Operating Instructions included in the scope of supply.
Please refer to the Operating Instructions and other documentation provided by your supplier for detailed information.

Basic safety instructions

Requirements for the personnel

The personnel must fulfill the following requirements for its tasks:

- ▶ Trained, qualified specialists must have a relevant qualification for this specific function and task.
- ▶ Are authorized by the plant owner/operator.
- ▶ Are familiar with federal/national regulations.
- ▶ Before starting work, read and understand the instructions in the manual and supplementary documentation as well as the certificates (depending on the application).
- ▶ Follow instructions and comply with basic conditions.

Intended use

The active barrier is used for the safe isolation of 0/4 to 20 mA standard signal circuits. An intrinsically safe version is optionally available for operation in Zone 2. The device is designed for installation on DIN rails in accordance with IEC 60715.

Product liability: The manufacturer does not accept any responsibility for damage that results from non-designated use and from failure to comply with the instructions in this manual.

Operational safety

Risk of injury!

- ▶ Operate the device only if it is in proper technical condition, free from errors and faults.
- ▶ The operator is responsible for interference-free operation of the device.

Incoming acceptance and product identification

Incoming acceptance

On receipt of the delivery:

1. Check the packaging for damage.
 - ↳ Report all damage immediately to the manufacturer.
Do not install damaged components.
2. Check the scope of delivery using the delivery note.
3. Compare the data on the nameplate with the order specifications on the delivery note.
4. Check the technical documentation and all other necessary documents, e.g. certificates, to ensure they are complete.



If one of the conditions is not satisfied, contact the manufacturer.

Product identification

The device can be identified in the following ways:

- Nameplate specifications

Hazardous area

To eliminate danger to persons or the facility when the device is used in the hazardous area (e.g. explosion protection):

- ▶ Check the nameplate to verify if the device ordered can be put to its intended use in the hazardous area.
- ▶ Observe the specifications in the separate supplementary documentation that is an integral part of these instructions.

Product safety

This device is designed in accordance with good engineering practice to meet state-of-the-art safety requirements, has been tested, and left the factory in a condition in which it is safe to operate.

Installation instructions

- The device's IP20 degree of protection is intended for a clean and dry environment.
- Do not expose the device to mechanical and/or thermal stress that exceeds the specified limits.
- The device is intended for installation in a cabinet or similar housing. The device may only be operated as an installed device.
- To protect against mechanical or electrical damage, the device must be installed in an appropriate housing with a suitable degree of protection according to IEC/EN 60529.
- The device fulfills the EMC regulations for the industrial sector.
- NE 21: Electromagnetic compatibility (EMC) of industrial process and laboratory control equipment is met under the following condition: power failures of up to 20 ms must be bridged with a suitable power supply.

- Extended order code with breakdown of the measuring instrument features on the delivery note

Nameplate

Do you have the correct device?

The nameplate provides you with the following information on the device:

- Manufacturer identification, device designation
- Order code
- Extended order code
- Serial number
- Tag name (TAG) (optional)
- Technical values, e.g. supply voltage, current consumption, ambient temperature, communication-specific data (optional)
- Degree of protection
- Approvals with symbols
- Reference to Safety Instructions (XA) (optional)

- ▶ Compare the information on the nameplate with the order.

Name and address of manufacturer

Name of manufacturer:	Endress+Hauser Wetzer GmbH + Co. KG
Address of manufacturer:	Obere Wank 1, D-87484 Nesselwang
Model/type reference:	RN22

Storage and transport

Storage temperature: -40 to +80 °C (-40 to +176 °F)

Mounting

Mounting requirements

Dimensions

Width (B) x length (L) x height (H) (with terminals): 12.5 mm (0.49 in) x 116 mm (4.57 in) x 107.5 mm (4.23 in)

Mounting location

The device is designed for installation on 35 mm (1.38 in) DIN rails in accordance with IEC 60715 (TH35).

NOTICE

- ▶ When using in hazardous areas, the limit values of the certificates and approvals must be observed.

Important ambient conditions

Ambient temperature range	-40 to 60 °C (-40 to 140 °F)	Storage temperature	-40 to 80 °C (-40 to 176 °F)
Degree of protection	IP 20	Overvoltage category	II
Pollution degree	2	Humidity	5 to 95 %
Altitude	≤ 2 000 m (6 562 ft)	Insulation class	Class III

Mounting the DIN rail bus connector

- i** If using the DIN rail bus connector to the power supply, clip it onto the DIN rail BEFORE mounting the device. It is essential that you pay attention to the orientation of the module and the DIN rail bus connector: the snap-on clip should be at the bottom and the connector piece on the left.

Electrical connection

Connecting requirements

A flat-blade screw driver is required to establish an electrical connection to screw or push-in terminals.

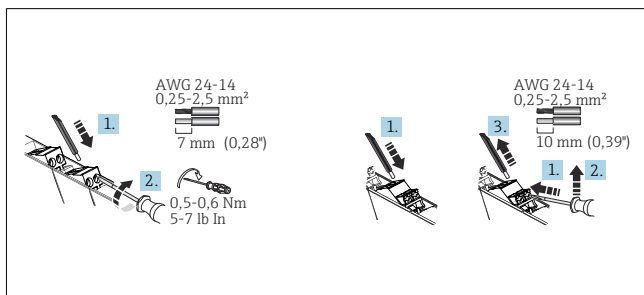

2 Electrical connection using screw terminals (left) and push-in terminals (right)

CAUTION

Destruction of parts of the electronics

- ▶ Switch off the power supply before installing and connecting the device.

NOTICE

Destruction or malfunction of parts of the electronics

- ▶ **ESD** - Electrostatic discharge. Protect the terminals and HART lugs on the front from electrostatic discharge.

Maximum relative humidity: < 95%

- i** Pack the device for storage and transportation in such a way that it is reliably protected against impact and external influences. The original packaging provides the best protection.

Avoid the following environmental influences during storage:

- Direct sunlight
- Proximity to hot objects
- Mechanical vibration
- Aggressive media

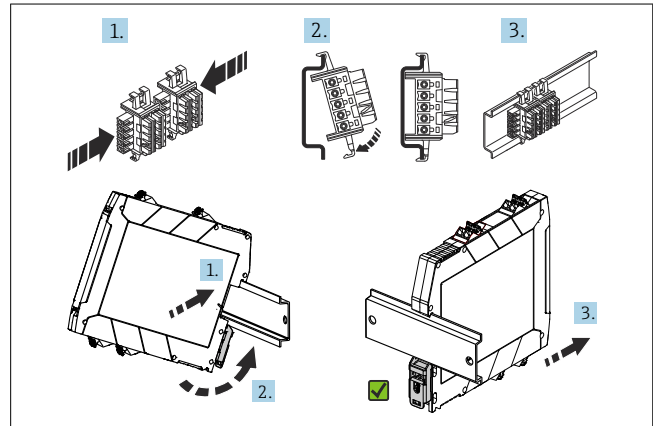

1 Mounting the DIN rail bus connector 12,5 mm (0,5 in) (top) and mounting on DIN rail (bottom)

Installing a DIN rail device

The device can be installed in any position (horizontal or vertical) on the DIN rail without lateral clearance from neighboring devices. No tools are required for installation. The use of end brackets (type WEW "35/1" or similar) on the DIN rail is recommended as an end support for the device.

- i** When installing several devices side by side, it is important to ensure that the maximum side wall temperature of 80 °C (176 °F) of the individual devices is not exceeded. If this cannot be guaranteed, mount the devices at a distance from one another or ensure sufficient cooling.

- ▶ A shielded cable is recommended for HART communication. Observe grounding concept of the plant.

- i** Only use copper cables with a minimum temperature rating of 75 °C (167 °F) as the connection cable.

Important connection data

Performance characteristics

Power supply ¹⁾

Supply voltage	24 V _{DC} (-20% / +25%)
Supply current to the DIN rail bus connector	max. 400 mA
Power consumption at 24 V _{DC}	1-channel: ≤ 1.5 W (20 mA) / ≤ 1.6 W (22 mA) 2-channel: ≤ 3 W (20 mA) / ≤ 3.2 W (22 mA) Signal doubler: ≤ 2.4 W (20 mA) / ≤ 2.5 W (22 mA)
Current consumption at 24 V _{DC}	1-channel: ≤ 0.07 A (20 mA) / ≤ 0.07 A (22 mA) 2-channel: ≤ 0.13 A (20 mA) / ≤ 0.14 A (22 mA) Signal doubler: ≤ 0.1 A (20 mA) / ≤ 0.11 A (22 mA)
Power loss at 24 V _{DC}	1-channel: ≤ 1.2 W (20 mA) / ≤ 1.3 W (22 mA) 2-channel: ≤ 2.4 W (20 mA) / ≤ 2.5 W (22 mA) Signal doubler: ≤ 2.1 W (20 mA) / ≤ 2.2 W (22 mA)

1) The data apply to the following operating scenario: input active/output active/output load 0 Ω. When external voltages are connected to the output, the power loss in the

device may increase. The power loss in the device can be reduced by connecting an external output load.

Input data

Input signal range (underrange/overrange)	0 to 22 mA
Function range, input signal	0/4 to 20 mA
Transmitter supply voltage	$\geq 16.5 \text{ V} / (20 \text{ mA})$

Output data

Output signal range (underload/overload range)	0 to 22 mA
Function range, output signal	0/4 to 20 mA
Transmission behavior	1:1 to input signal
Step response (10 to 90 %)	1 ms
Signal doubler output 2: signal delay due to HART filter	< 40 ms
Load	$\leq 500 \Omega$ (for active mode)
Transmissible communication protocols	HART

Accuracies

Transmission error max. (0 to 20.5 mA)	< 0.1 % / of full scale value (<20 μA)
Temperature coefficient	< 0.01 % /K

Galvanic isolation

Power supply / input; power supply / output	Testing voltage: 1500 V _{AC} 50 Hz, 1 min
Input / output; output / output	Testing voltage: 500 V _{AC} 50 Hz, 1 min



For detailed technical data, see the Operating Instructions

Quick wiring guide

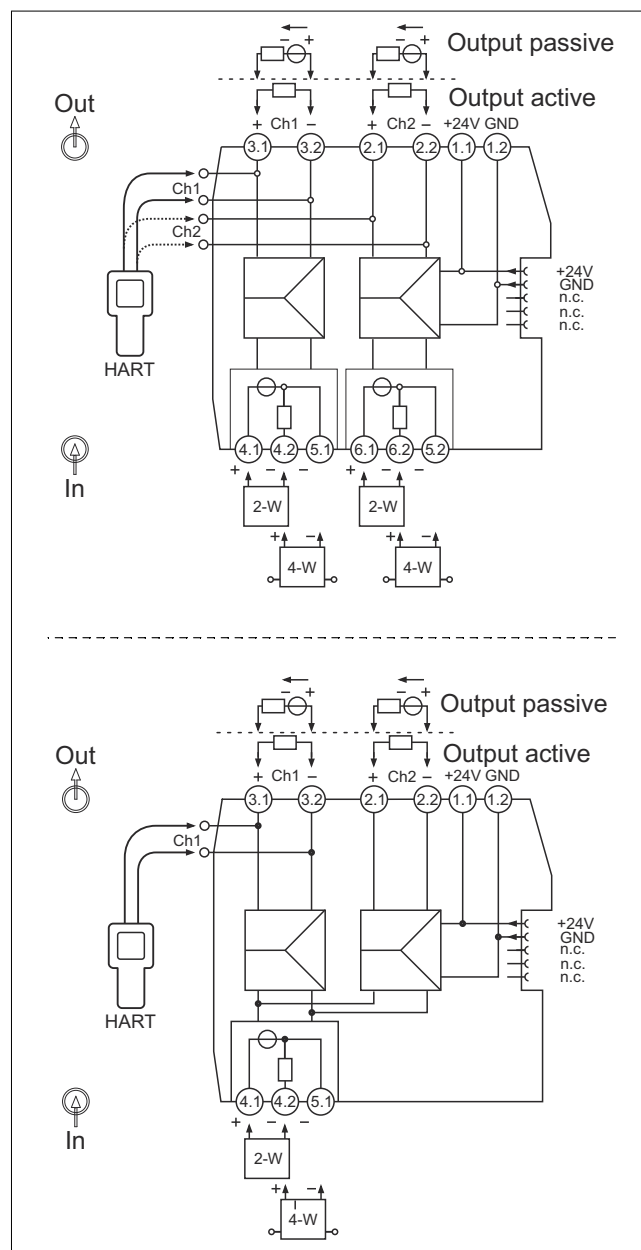

3 Terminal assignment: 1- and 2-channel version (top), signal doubler (bottom)

Connection for operation with active output:

1. Connect + with 3.2/2.2.
2. Connect - with 3.1/2.1.
 - ↳ The operating mode is switched automatically.

Connection for operation with passive output:

1. Connect + with 3.1/2.1.
2. Connect - to 3.2/2.2.
 - ↳ The operating mode is switched automatically.

i HART communicators can be connected to the HART connecting points. Ensure an adequate external resistance ($\geq 230 \Omega$) in the output circuit.

Connecting the supply voltage

Power can be supplied via terminals 1.1 and 1.2 or via the DIN rail bus connector.

i The device may only be powered by a power unit with an energy-limited circuit in accordance with UL/EN/IEC 61010-1, Section 9.4 and the requirements of Table 18.

Using the power and error message module to supply power

It is recommended to use the RNF22 power and error message module to provide the supply voltage to the DIN rail bus connector. An overall current of 3.75 A is possible with this option.

Supply to the DIN rail bus connector via terminals

Devices installed side by side can be powered via the terminals of the device up to a total current consumption of 400 mA. The connection is via the DIN rail bus

connector. The installation of a 630 mA fuse (semi-delay or slow-blow) upstream is recommended.

NOTICE

The simultaneous use of terminals and DIN rail bus connectors to supply power is not permitted! The tapping of energy from the DIN rail bus connector for further distribution is not permitted.

- ▶ The supply voltage must never be connected directly to the DIN rail bus connector!

Display and operating elements

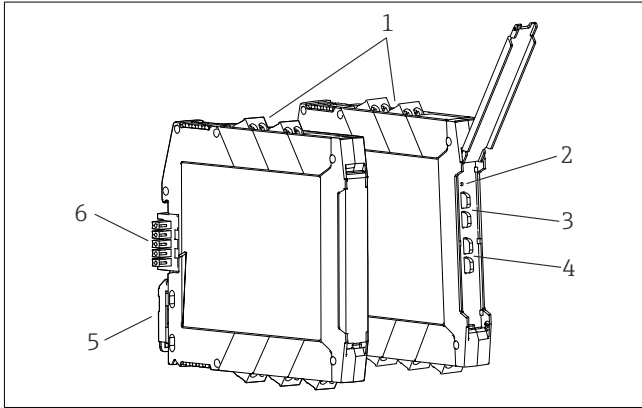

4 Display and operating elements

- 1 Plug-in screw or push-in terminal
- 2 Green LED "On", power supply
- 3 Connection lugs for HART communication (channel 1)
- 4 Connection lugs for HART communication (channel 2, option)
- 5 DIN rail clip for DIN rail mounting
- 6 DIN rail bus connector (optional)

Local operation

Hardware settings/configuration

No manual hardware settings are required at the device for commissioning.

Attention must be paid to the different terminal assignment when connecting 2-/4-wire transmitters. At the output side, the connected system is detected and automatic switching takes place between the active and passive mode.

Maintenance and cleaning

No special maintenance work is required for the device.

Cleaning of surfaces not in contact with the medium

- Recommendation: Use a lint-free cloth that is either dry or slightly dampened using water.
- Do not use any sharp objects or aggressive cleaning agents that corrode the surfaces (displays, housing, for example) and seals.

- Do not use high-pressure steam.
- Observe the degree of protection of the device.



The cleaning agent used must be compatible with the materials of the device configuration. Do not use cleaning agents with concentrated mineral acids, bases or organic solvents.