

# Safety Instructions

## Cerabar

### PMC21, PMP21, PMP23

ATEX, IECEx: Ex ia IIC T4 Ga/Gb  
Ex ia IIC T4 Gb





# Cerabar PMC21, PMP21, PMP23

## Table of contents

About this document .....	4
Associated documentation .....	4
Supplementary documentation .....	4
Certificates and declarations .....	4
Manufacturer address .....	5
Other standards .....	5
Extended order code .....	5
Safety instructions: General .....	7
Safety instructions: Specific conditions of use .....	7
Safety instructions: Installation .....	8
Safety instructions: Zone 0 .....	9
Temperature tables .....	9
Connection data .....	9

**About this document**

The document number of these Safety Instructions (XA) must match the information on the nameplate.

**Associated documentation**

All documentation is available on the Internet:

[www.endress.com/Deviceviewer](http://www.endress.com/Deviceviewer)  
(enter the serial number from the nameplate).



If not yet available, a translation into EU languages can be ordered.

To commission the device, please observe the Operating Instructions pertaining to the device:

BA01271P

**Supplementary documentation**

Explosion protection brochure: CP00021Z

The explosion protection brochure is available on the Internet:  
[www.endress.com/Downloads](http://www.endress.com/Downloads)

**Certificates and declarations****EU Declaration of Conformity**

Declaration Number:  
EU\_01165

The EU Declaration of Conformity is available on the Internet:  
[www.endress.com/Downloads](http://www.endress.com/Downloads)

**EU type-examination certificate**

Certificate number:  
SEV 14 ATEX 0134

List of applied standards: See EU Declaration of Conformity.

**IEC Declaration of Conformity**

Certificate number:  
IECEx SEV 14.0008

Affixing the certificate number certifies conformity with the following standards (depending on the device version):

- IEC 60079-0 : 2017
- IEC 60079-11 : 2011
- IEC 60079-26 : 2021

<b>Manufacturer address</b>	Endress+Hauser SE+Co. KG Hauptstraße 1 79689 Maulburg, Germany Address of the manufacturing plant: See nameplate.
<b>Other standards</b>	Among other things, the following standards shall be observed in their current version for proper installation: <ul style="list-style-type: none"> <li>■ IEC/EN 60079-14: "Explosive atmospheres - Part 14: Electrical installations design, selection and erection"</li> <li>■ EN 1127-1: "Explosive atmospheres - Explosion prevention and protection - Part 1: Basic concepts and methodology"</li> </ul>
<b>Extended order code</b>	The extended order code is indicated on the nameplate, which is affixed to the device in such a way that it is clearly visible. Additional information about the nameplate is provided in the associated Operating Instructions.

#### Structure of the extended order code

PMC21, PMP2x	-	*****	+	A*B*C*D*E*F*G*..
<i>(Device type)</i>		<i>(Basic specifications)</i>		<i>(Optional specifications)</i>

\* = Placeholder

At this position, an option (number or letter) selected from the specification is displayed instead of the placeholders.

#### *Basic specifications*

The features that are absolutely essential for the device (mandatory features) are specified in the basic specifications. The number of positions depends on the number of features available.

The selected option of a feature can consist of several positions.

#### *Optional specifications*

The optional specifications describe additional features for the device (optional features). The number of positions depends on the number of features available. The features have a 2-digit structure to aid identification (e.g. JA). The first digit (ID) stands for the feature group and consists of a number or a letter (e.g. J = Test, Certificate). The second digit constitutes the value that stands for the feature within the group (e.g. A = 3.1 material (wetted parts), inspection certificate).

More detailed information about the device is provided in the following tables. These tables describe the individual positions and IDs in the extended order code which are relevant to hazardous locations.

### Extended order code: Cerabar



The following specifications reproduce an extract from the product structure and are used to assign:

- This documentation to the device (using the extended order code on the nameplate).
- The device options cited in the document.

#### *Device type*

PMC21, PMP21, PMP23

#### *Basic specifications*

Position 1, 2 (Approval)		
Selected option		Description
PMC21 PMP2x	BA	ATEX II 1/2 G Ex ia IIC T4 Ga/Gb
	BB	ATEX II 2 G Ex ia IIC T4 Gb
	IA	IECEX Ex ia IIC T4 Ga/Gb

Position 3 (Output)		
Selected option		Description
PMC21 PMP2x	1	4 to 20 mA

Position 4 (Electrical Connection)		
Selected option		Description
PMC21 PMP2x	A	Cable 5 m, IP66/68 NEMA Type 4X/6P Encl.
	B	Cable 10 m, IP66/68 NEMA Type 4X/6P Encl.
	C	Cable 25 m, IP66/68 NEMA Type 4X/6P Encl.
	M	Plug M12, IP65/67 NEMA Type 4X Encl.
	U	Valve plug ISO4400 M16, IP65 NEMA Type 4X Encl.
	V	Valve plug ISO4400 NPT1/2, IP65 NEMA Type 4X Encl.
PMP23	N	Plug M12, IP66/69 NEMA Type 4X Encl.

### *Optional specifications*

No options specific to hazardous locations are available.

#### **Safety instructions: General**

- The device is intended to be used in explosive atmospheres as defined in the scope of IEC 60079-0 or equivalent national standards. If no potentially explosive atmospheres are present or if additional protective measures have been taken: The device may be operated according to the manufacturer's specifications.
- Staff must meet the following conditions for mounting, electrical installation, commissioning and maintenance of the device:
  - Be suitably qualified for their role and the tasks they perform
  - Be trained in explosion protection
  - Be familiar with national regulations
- Install the device according to the manufacturer's instructions and national regulations.
- Only use the device in media to which the wetted materials have sufficient durability.
- Avoid electrostatic charging:
  - Of plastic surfaces (e.g. enclosure, sensor element, special varnishing, attached additional plates, ...)
  - Of isolated capacities (e.g. isolated metallic plates)

#### **Safety instructions: Specific conditions of use**

- To avoid electrostatic charging: Do not rub surfaces with a dry cloth.
- In the event of additional or alternative special varnishing on the enclosure or other metal parts or for adhesive plates:
  - Observe the danger of electrostatic charging and discharge.
  - Do not install in the vicinity of processes ( $\leq 0.5$  m) generating strong electrostatic charges.

## Safety instructions: Installation

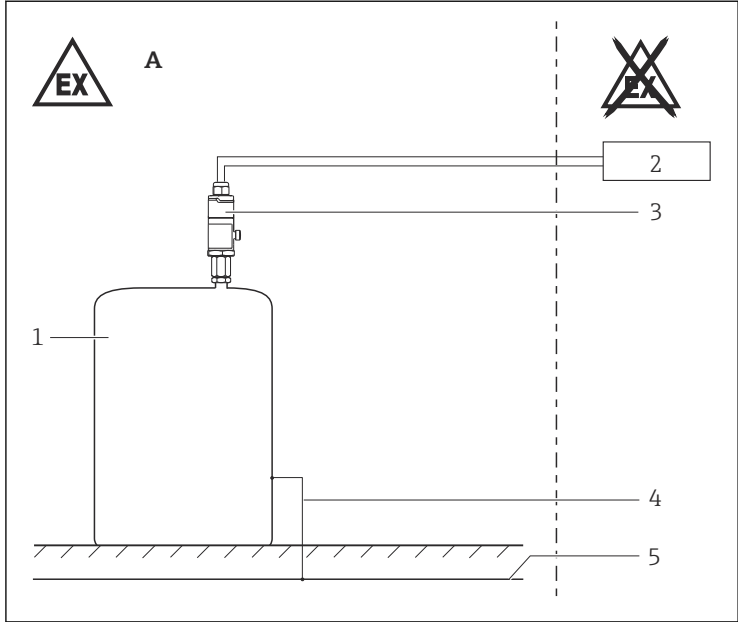

### 1

- A Zone 1  
 1 Tank; Zone 0  
 2 Certified associated apparatus  
 3 Transmitter enclosure  
 4 Potential equalization line  
 5 Potential equalization

### Intrinsic safety

- When the device is connected to certified intrinsically safe circuits of Category Ex ib for Equipment Groups IIC and IIB, the type of protection changes to Ex ib IIC and Ex ib IIB. Do not operate the sensor in Zone 0 if connecting to an intrinsically safe circuit of Category Ex ib.
- The intrinsically safe input power circuit of the device is isolated from ground. The dielectric strength is at least  $500 V_{\text{rms}}$ .

### Potential equalization

If the potential equalization cannot be guaranteed by the installation: In order to avoid electrostatic charging, integrate metallic parts of the enclosure into the potential equalization.



**Safety instructions:**  
**Zone 0**

Associated devices with galvanic isolation between the intrinsically safe and non-intrinsically safe circuits are preferred.

**Temperature tables**

Temperature class	Process temperature $T_p$ (process)	Ambient temperature $T_a$ (ambient): enclosure
T4	$\leq 100\text{ }^\circ\text{C}$	$-40\text{ }^\circ\text{C} \leq T_a \leq +70\text{ }^\circ\text{C}$

**Connection data**

Electrical data
$U_i \leq 30\text{ V}$ $I_i \leq 100\text{ mA}$ $P_i \leq 0.8\text{ W}$ $C_i \leq 11.6\text{ nF}$ $L_i = 0$







71645006

[www.addresses.endress.com](http://www.addresses.endress.com)

---