

Technical Information

Micropilot FMR62B

PROFIBUS PA

Free-space radar



Level measurement in liquids

Application

- Continuous, non-contact level measurement of liquids, pastes and sludges
- Process connections: Flanges
- Maximum measuring range: 80 m (262 ft)
- Temperature: -196 to +450 °C (-321 to +842 °F)
- Pressure: -1 to +160 bar (-14.5 to +2 321 psi)
- Accuracy: ±1 mm (±0.04 in)

Your benefits

- PTFE antenna or ceramic sealed high-temperature horn antenna
- Reliable measurement thanks to strong signal focusing, even with multiple internal fixtures
- Easy, guided commissioning with intuitive user interface
- *Bluetooth*® wireless technology for commissioning, operation and maintenance
- Longer calibration cycles with Radar Accuracy Index

Table of contents

Important document information	3	Process	43
Symbols	3	Process pressure range	43
Graphic conventions	4	Dielectric constant	44
Function and system design	4	Mechanical construction	45
Measuring principle	4	Dimensions	45
Reliability	5	Weight	54
Input	5	Materials	55
Measured variable	5	Operability	60
Measuring range	5	Operation concept	60
Operating frequency	12	Languages	60
Transmission power	12	Local operation	60
Output	12	Local display	60
PROFIBUS PA	12	Remote operation	62
Signal on alarm	12	System integration	62
Linearization	12	Supported operating tools	63
Protocol-specific data	13	Certificates and approvals	63
Power supply	14	CE mark	63
Terminal assignment	14	RoHS	63
Terminals	15	RCM marking	63
Available device plugs	15	Ex approvals	63
Supply voltage	15	Pressure equipment with permitted pressure ≤ 200 bar (2 900 psi)	63
Potential equalization	15	Radio approval	63
Cable entries	16	EN 302729 radio standard	63
Cable specification	16	EN 302372 radio standard	64
Overvoltage protection	16	FCC	64
Performance characteristics	17	Industry Canada	65
Reference operating conditions	17	External standards and guidelines	65
Maximum measured error	17	Ordering information	65
Measured value resolution	18	Calibration	66
Response time	18	Service	66
Influence of ambient temperature	18	Test, certificate, declaration	67
Influence of gas phase	18	Identification	67
Installation	19	Application packages	67
Mounting location	19	Heartbeat Technology	67
Orientation	20	Accessories	68
Installation instructions	21	Weather protection cover: 316L, XW112	68
Beam angle	24	Weather protection cover, plastic, XW111	69
Special mounting instructions	26	Remote display FHX50B	69
Environment	29	Gas-tight feedthrough	70
Ambient temperature range	29	Field Xpert SMT70	71
Ambient temperature limits	29	DeviceCare SFE100	71
Storage temperature	42	FieldCare SFE500	71
Climate class	42	RID14	71
Installation height as per IEC61010-1 Ed.3	42	RID16	71
Degree of protection	42	Fieldgate SFG500	72
Vibration resistance	43	Documentation	72
Electromagnetic compatibility (EMC)	43	Registered trademarks	73

Important document information

Symbols

Safety symbols

 **DANGER**

This symbol alerts you to a dangerous situation. Failure to avoid this situation will result in serious or fatal injury.

 **WARNING**

This symbol alerts you to a potentially dangerous situation. Failure to avoid this situation can result in serious or fatal injury.

 **CAUTION**

This symbol alerts you to a potentially dangerous situation. Failure to avoid this situation can result in minor or medium injury.

 **NOTICE**

This symbol alerts you to a potentially harmful situation. Failure to avoid this situation can result in damage to the product or something in its vicinity.

Electrical symbols



Direct current



Alternating current



Direct current and alternating current



Ground connection

A grounded terminal which, as far as the operator is concerned, is grounded via a grounding system.



Protective earth (PE)

Ground terminals that must be connected to ground prior to establishing any other connections. The ground terminals are located on the inside and outside of the device.

- Inner ground terminal; protective earth is connected to the mains supply.
- Outer ground terminal; device is connected to the plant grounding system.

Symbols for certain types of information and graphics

 **Permitted**

Procedures, processes or actions that are permitted

 **Preferred**

Procedures, processes or actions that are preferred

 **Forbidden**

Procedures, processes or actions that are forbidden

 **Tip**

Indicates additional information



Reference to documentation



Reference to graphic

1, 2, 3, ...

Item numbers

A, B, C, ...

Views

 **Hazardous area**

Indicates the hazardous area

 **Safe area (non-hazardous area)**

Indicates the non-hazardous area

Graphic conventions

- Installation, explosion and electrical connection drawings are presented in simplified format
- Devices, assemblies, components and dimensional drawings are presented in reduced-line format
- Dimensional drawings are not to-scale representations; the dimensions indicated are rounded off to 2 decimal places
- Unless otherwise described, flanges are presented with sealing surface form EN1091-1, B2; ASME B16.5, RF; JIS B2220, RF

Function and system design

Measuring principle

The Micropilot is a "downward-looking" measuring system, operating based on the frequency modulated continuous wave method (FMCW). The antenna emits an electromagnetic wave at a continuously varying frequency. This wave is reflected by the product and received again by the antenna.

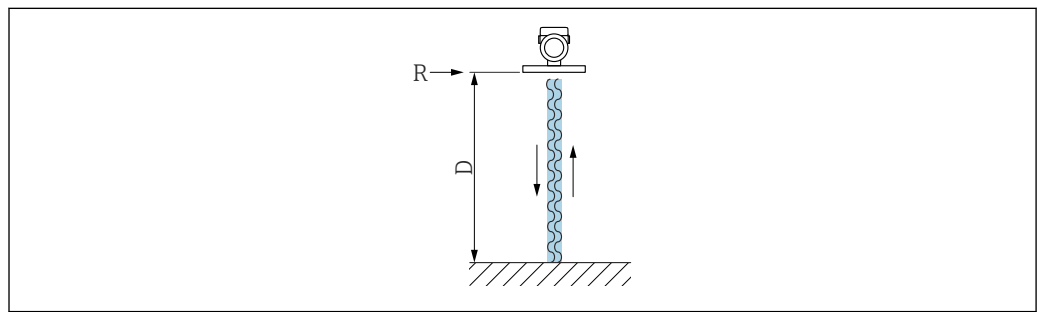

A0032017

1 FMCW principle: transmission and reflection of the continuous wave

R Reference point of measurement

D Distance between reference point and product surface

The frequency of this wave is modulated in the form of a sawtooth signal between two limit frequencies f_1 and f_2 :

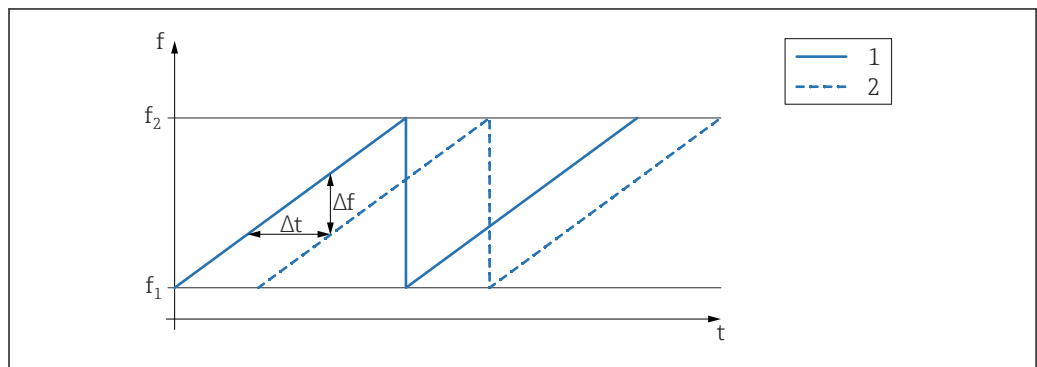

A0023771

2 FMCW principle: result of frequency modulation

1 Transmitted signal

2 Received signal

This results in the following difference frequency at any time between the transmitted signal and the received signal:

$$\Delta f = k \Delta t$$

where Δt is the run time and k is the specified increase in frequency modulation.

Δt is given by the distance D between the reference point R and the product surface:

$$D = (c \Delta t) / 2$$

where c is the speed of propagation of the wave.

In summary, D can be calculated from the measured difference frequency Δf . D is then used to determine the content of the tank or silo.

Reliability

IT security

The manufacturer warranty is valid only if the product is installed and used as described in the Operating Instructions. The product is equipped with security mechanisms to protect it against any inadvertent changes to the settings.

IT security measures, which provide additional protection for the product and associated data transfer, must be implemented by the operators themselves in line with their security standards.

Input

Measured variable

The measured variable is the distance between the reference point and the product surface. The level is calculated based on "E", the empty distance entered.

Measuring range

The measuring range starts at the point where the beam hits the tank floor. Levels below this point cannot be measured, particularly in the case of spherical bases or conical outlets.

Maximum measuring range

The maximum measuring range depends on the antenna size and design.

Antenna	Maximum measuring range
Horn, 316L, 65 mm (2.6 in)	80 m (262 ft)
Drip-off, PTFE, 50 mm (2 in)	50 m (164 ft)
Cladded flush mount, PTFE, 50 mm (2 in)	50 m (164 ft)
Cladded flush mount, PTFE, 80 mm (3 in)	80 m (262 ft)

Usable measuring range

The usable measuring range depends on the antenna size, the medium's reflective properties, the installation position and any possible interference reflections.

In principle, measurement is possible up to the tip of the antenna.

To avoid any material damage from corrosive or aggressive media or deposit buildup on the antenna, the end of the measuring range should be selected 10 mm (0.4 in) before the tip of the antenna.

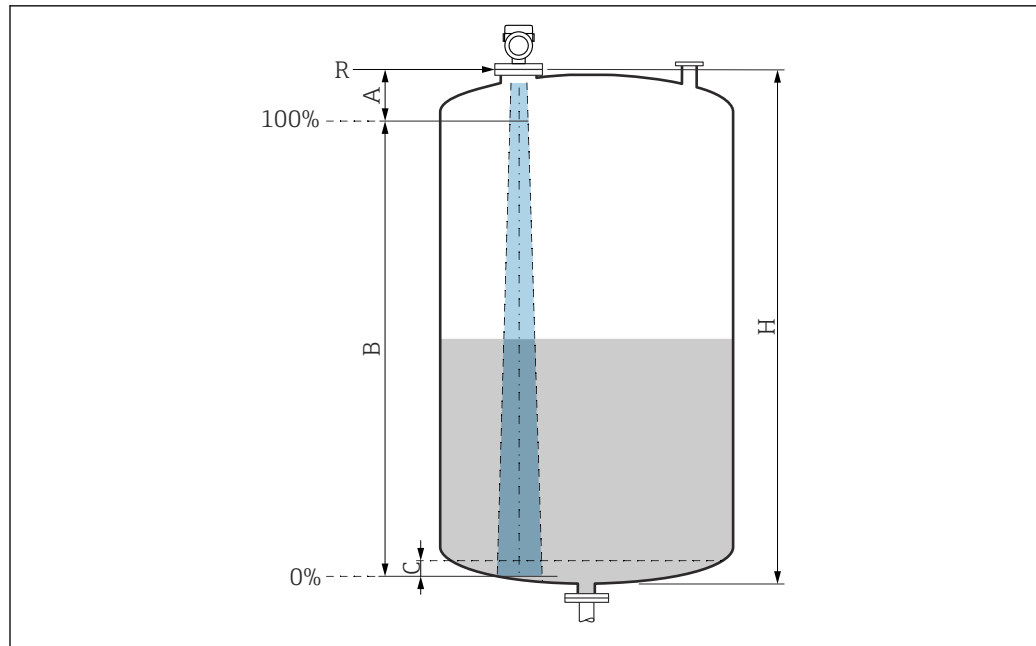

A0051658

3 Usable measuring range

- A Length of antenna + 10 mm (0.4 in)
- B Usable measuring range
- C 50 to 80 mm (1.97 to 3.15 in); medium $\epsilon_r < 2$
- H Vessel height
- R Reference point of measurement, varies depending on the antenna system

For further information on the reference point, see → Mechanical construction.

In the case of media with a low dielectric constant, $\epsilon_r < 2$, the tank floor may be visible through the medium at very low levels (lower than level C). Reduced accuracy must be expected in this range. If this is not acceptable, the zero point should be positioned at a distance C above the tank floor in these applications → Usable measuring range.

The media groups and the possible measuring range are described as a function of the application and media group in the following section. If the dielectric constant of the medium is not known, to ensure a reliable measurement assume the medium belongs to group B.

Media groups

- **A0** (ϵ_r 1.2 to 1.4)
e.g. n-butane, liquid nitrogen, liquid hydrogen
- **A** (ϵ_r 1.4 to 1.9)
Non-conductive liquids, e.g. liquefied gas
- **B** (ϵ_r 1.9 to 4)
Non-conductive liquids, e.g. gasoline, oil, toluene, etc.
- **C** (ϵ_r 4 to 10)
e.g. concentrated acid, organic solvents, ester, aniline, etc.
- **D** ($\epsilon_r >10$)
Conductive liquids, aqueous solutions, diluted acids, bases and alcohol

i **Measurement of the following media with absorbing gas phase**

For example:

- Ammonia
- Acetone
- Methylene chloride
- Methyl ethyl ketone
- Propylene oxide
- VCM (vinyl chloride monomer)

To measure absorbing gases, either use a guided radar, measuring devices with another measuring frequency or another measuring principle.

If measurements must be performed in one of these media, please contact Endress+Hauser.

i For the relative permittivity values (ϵ_r values) of many media commonly used in industry, please refer to:

- Relative permittivity (ϵ_r value), Compendium CP01076F
- The Endress+Hauser "DC Values app" (available for Android and iOS)

Measurement in storage vessel

Storage vessel - measuring conditions

Calm medium surface (e.g. bottom filling, filling via immersion tube or rare filling from above)

PTFE Drip-off antenna, 50 mm (2 in) in storage vessel

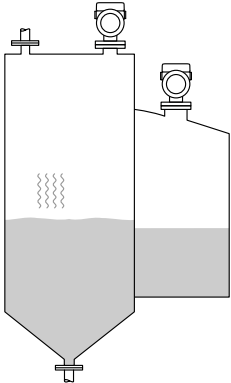
	Media group	Measuring range
	A0 (ϵ_r 1.2 to 1.4)	7 m (23 ft)
	A (ϵ_r 1.4 to 1.9)	12 m (39 ft)
	B (ϵ_r 1.9 to 4)	23 m (75 ft)
	C (ϵ_r 4 to 10)	40 m (131 ft)
	D ($\epsilon_r >10$)	50 m (164 ft)

Antenna, PTFE clad flush mount, 50 mm (2 in) in storage vessel

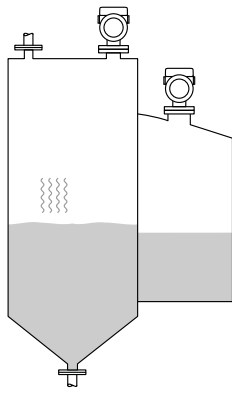
	Media group	Measuring range
	AO (ϵ_r 1.2 to 1.4)	7 m (23 ft)
	A (ϵ_r 1.4 to 1.9)	12 m (39 ft)
	B (ϵ_r 1.9 to 4)	23 m (75 ft)
	C (ϵ_r 4 to 10)	40 m (131 ft)
	D (ϵ_r >10)	50 m (164 ft)

Antenna, PTFE clad flush mount, 80 mm (3 in) in storage vessel

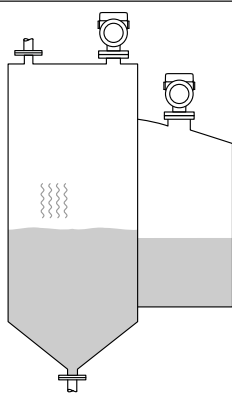
	Media group	Measuring range
	AO (ϵ_r 1.2 to 1.4)	22 m (72 ft)
	A (ϵ_r 1.4 to 1.9)	40 m (131 ft)
	B (ϵ_r 1.9 to 4)	50 m (164 ft)
	C (ϵ_r 4 to 10)	65 m (231 ft)
	D (ϵ_r >10)	80 m (262 ft)

Antenna, horn 316L, 65 mm (2.6 in) in storage vessel

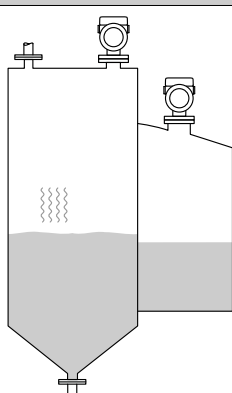
	Media group	Measuring range
	AO (ϵ_r 1.2 to 1.4)	20 m (66 ft)
	A (ϵ_r 1.4 to 1.9)	36 m (118 ft)
	B (ϵ_r 1.9 to 4)	45 m (148 ft)
	C (ϵ_r 4 to 10)	58 m (190 ft)
	D (ϵ_r >10)	72 m (236 ft)

Measurement in buffer vessel

Buffer vessel - measuring conditions

Moving medium surface (e.g. permanent free filling from above, mixing jets)

PTFE Drip-off antenna, 50 mm (2 in) in buffer vessel

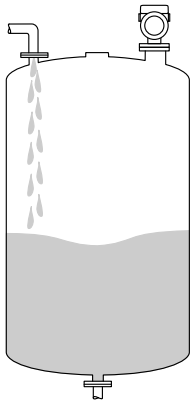
	Media group	Measuring range
	A0 (ϵ_r 1.2 to 1.4)	4 m (13 ft)
	A (ϵ_r 1.4 to 1.9)	7 m (23 ft)
	B (ϵ_r 1.9 to 4)	13 m (43 ft)
	C (ϵ_r 4 to 10)	28 m (92 ft)
	D (ϵ_r >10)	44 m (144 ft)

Antenna, PTFE cladded flush mount, 50 mm (2 in) in buffer vessel

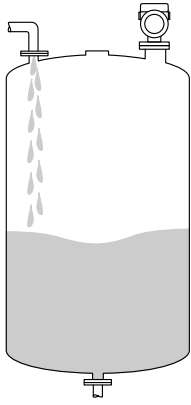
	Media group	Measuring range
	A0 (ϵ_r 1.2 to 1.4)	4 m (13 ft)
	A (ϵ_r 1.4 to 1.9)	7 m (23 ft)
	B (ϵ_r 1.9 to 4)	13 m (43 ft)
	C (ϵ_r 4 to 10)	28 m (92 ft)
	D (ϵ_r >10)	44 m (144 ft)

Antenna, PTFE cladded flush mount, 80 mm (3 in) in buffer vessel

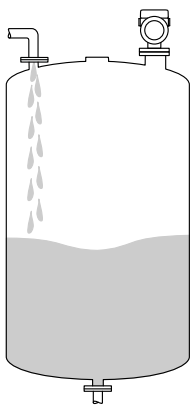
	Media group	Measuring range
	A0 (ϵ_r 1.2 to 1.4)	12 m (39 ft)
	A (ϵ_r 1.4 to 1.9)	23 m (75 ft)
	B (ϵ_r 1.9 to 4)	45 m (148 ft)
	C (ϵ_r 4 to 10)	60 m (197 ft)
	D (ϵ_r >10)	70 m (230 ft)

Antenna, horn 316L, 65 mm (2.6 in) in buffer vessel

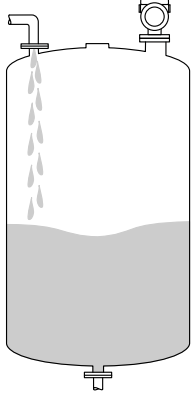
	Media group	Measuring range
	A0 (ϵ_r 1.2 to 1.4)	11 m (36 ft)
	A (ϵ_r 1.4 to 1.9)	21 m (69 ft)
	B (ϵ_r 1.9 to 4)	40 m (131 ft)
	C (ϵ_r 4 to 10)	54 m (177 ft)
	D (ϵ_r >10)	63 m (207 ft)

*Measurement in vessel with agitator***Vessel with agitator - measuring conditions**

Turbulent medium surface (e.g. from filling from above, stirrers and baffles)

PTFE Drip-off antenna, 50 mm (2 in) in vessel with agitator

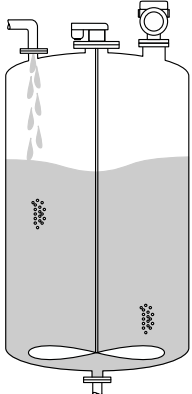
	Media group	Measuring range
	A0 (ϵ_r 1.2 to 1.4)	2 m (7 ft)
	A (ϵ_r 1.4 to 1.9)	4 m (13 ft)
	B (ϵ_r 1.9 to 4)	7 m (23 ft)
	C (ϵ_r 4 to 10)	15 m (49 ft)
	D (ϵ_r >10)	25 m (82 ft)

Antenna, PTFE clad flush mount, 50 mm (2 in) in vessel with agitator

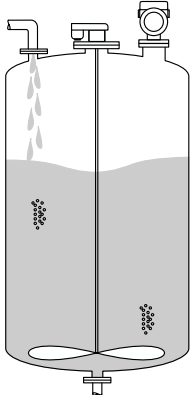
	Media group	Measuring range
	A0 (ϵ_r 1.2 to 1.4)	2 m (7 ft)
	A (ϵ_r 1.4 to 1.9)	4 m (13 ft)
	B (ϵ_r 1.9 to 4)	7 m (23 ft)
	C (ϵ_r 4 to 10)	15 m (49 ft)
	D (ϵ_r >10)	25 m (82 ft)

Antenna, PTFE cladded flush mount, 80 mm (3 in) in vessel with agitator

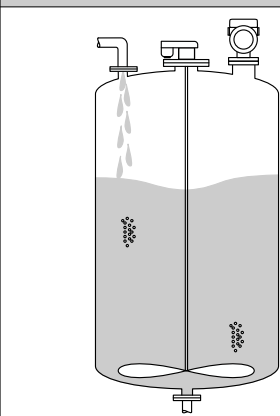
	Media group	Measuring range
	A0 (ϵ_r 1.2 to 1.4)	7 m (23 ft)
	A (ϵ_r 1.4 to 1.9)	13 m (43 ft)
	B (ϵ_r 1.9 to 4)	25 m (82 ft)
	C (ϵ_r 4 to 10)	50 m (164 ft)
	D (ϵ_r >10)	60 m (197 ft)

Antenna, horn 316L, 65 mm (2.6 in) in vessel with agitator

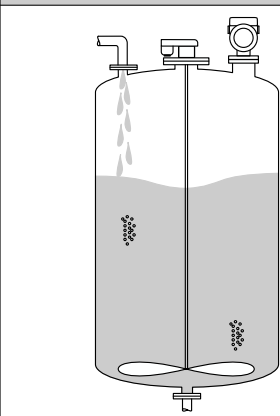
	Media group	Measuring range
	A0 (ϵ_r 1.2 to 1.4)	6 m (20 ft)
	A (ϵ_r 1.4 to 1.9)	12 m (39 ft)
	B (ϵ_r 1.9 to 4)	22 m (72 ft)
	C (ϵ_r 4 to 10)	45 m (147 ft)
	D (ϵ_r >10)	54 m (177 ft)

Measurement in stilling well

Stilling well process conditions

Application in vessels with a calm medium surface (e.g. bottom filling, filling via protection pipe or rare filling from above).

 Reduced accuracy can be expected depending on the stilling well diameter and quality of the stilling well.

Antenna, PTFE cladded flush mount, 80 mm (3 in) in stilling well

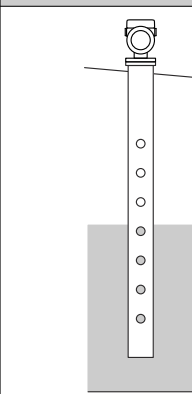
	Media group	Measuring range
	A0 (ϵ_r 1.2 to 1.4)	20 m (66 ft)
	A (ϵ_r 1.4 to 1.9)	20 m (66 ft)
	B (ϵ_r 1.9 to 4)	20 m (66 ft)
	C (ϵ_r 4 to 10)	20 m (66 ft)
	D (ϵ_r >10)	20 m (66 ft)

Measurement in bypass

Bypass process conditions

Application in vessels with moving medium surface (e.g. permanent free filling from above, mixing jets).



Reduced accuracy can be expected depending on the bypass diameter and quality of the pipe.

Antenna, PTFE clad flush mount, 80 mm (3 in) in bypass

	Media group	Measuring range
	A0 (ϵ_r 1.2 to 1.4)	20 m (66 ft)
	A (ϵ_r 1.4 to 1.9)	20 m (66 ft)
	B (ϵ_r 1.9 to 4)	20 m (66 ft)
	C (ϵ_r 4 to 10)	20 m (66 ft)
	D (ϵ_r >10)	20 m (66 ft)

Operating frequency

Approx. 80 GHz

Up to 8 devices can be installed in a tank without the devices mutually influencing one another.

Transmission power

- Peak power: <1.5 mW
- Average output power: <70 μ W

Output

PROFIBUS PA

According to EN 50170 Volume 2, IEC 61158-2

Signal coding:

Manchester Bus Powered (MBP) type 1

Data transmission rate:

31.25 kBit/s, voltage mode

Galvanic isolation:

Yes

Signal on alarm

Diagnostics in accordance with PROFIBUS PA Profile 3.02

Local display

Status signal (in accordance with NAMUR Recommendation NE 107):
Plain text display

Operating tool via service interface (CDI)

Status signal (in accordance with NAMUR Recommendation NE 107):
Plain text display

Operating tool via PROFIBUS PA communication

Status signal (in accordance with NAMUR Recommendation NE 107):
Plain text display

Linearization

The linearization function of the device allows the conversion of the measured value into any unit of length, weight, flow or volume.

Pre-programmed linearization curves

Linearization tables for calculating the volume in the following vessels are preprogrammed into the device:

- Pyramid bottom
- Conical bottom
- Angled bottom
- Horizontal cylinder
- Sphere

Other linearization tables of up to 32 value pairs can be entered manually.

Protocol-specific data

PROFIBUS PA

Manufacturer ID:
17 (0x11)

Ident number:
0x1568 or 0x9700

Profile version:
3.02

GSD file and version

Information and files available at:

- www.endress.com
On the product page for the device: Documents/Software → Device drivers
- www.profibus.com

Output values

Analog Input:

- Level linearized
- Distance
- Volume
- Terminal voltage
- Electronic temperature
- Sensor temperature
- Absolute echo amplitude
- Relative echo amplitude
- Area of incoupling
- Build-up index, optional (Guidance → Heartbeat Technology → Build-up detection → Build-up index)
- Foam index, optional (Diagnostics → Heartbeat Technology → Foam detection → Foam index)

Digital Input:

-  Is only available if the "Heartbeat Verification + Monitoring" application package was selected.
- 168 Build-up detected, optional (Guidance → Heartbeat Technology → Build-up detection → 168 Build-up detected)
- 952 Foam detected, optional (Guidance → Heartbeat Technology → Foam detection → 952 Foam detected)

Input values

Analog Output:

Analog value from PLC to be indicated on the display

Supported functions

- Identification & maintenance
Straightforward device identification on the part of the control system and nameplate
- Automatic Ident Number adoption
GSD compatibility mode for generic profile 0x9700 "Transmitter with 1 Analog Input"
- Physical layer diagnostics
Installation check of the PROFIBUS segment and device using terminal voltage and message monitoring
- PROFIBUS upload/download
Reading and writing parameters is up to ten times faster with PROFIBUS upload/download
- Condensed status
Straightforward and self-explanatory diagnostic information by categorizing diagnostic messages that occur

Power supply

Terminal assignment

Single compartment housing

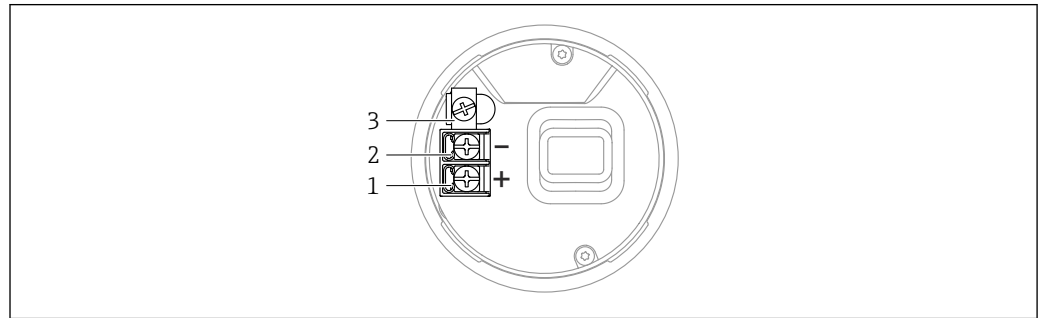

A0042594

▣ 4 Connection terminals and ground terminal in the connection compartment, single compartment housing

- 1 Positive terminal
- 2 Negative terminal
- 3 Internal ground terminal

Dual compartment housing

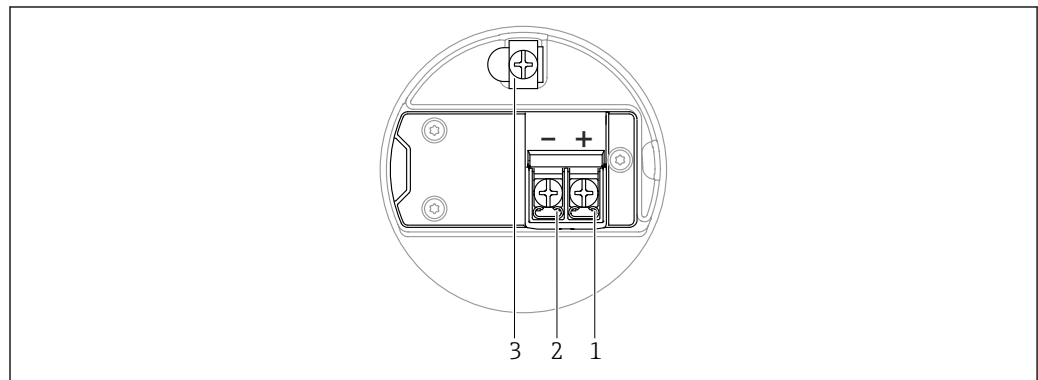

A0042803

▣ 5 Connection terminals and ground terminal in the connection compartment

- 1 Plus terminal
- 2 Minus terminal
- 3 Internal ground terminal

Dual compartment housing, L-shaped

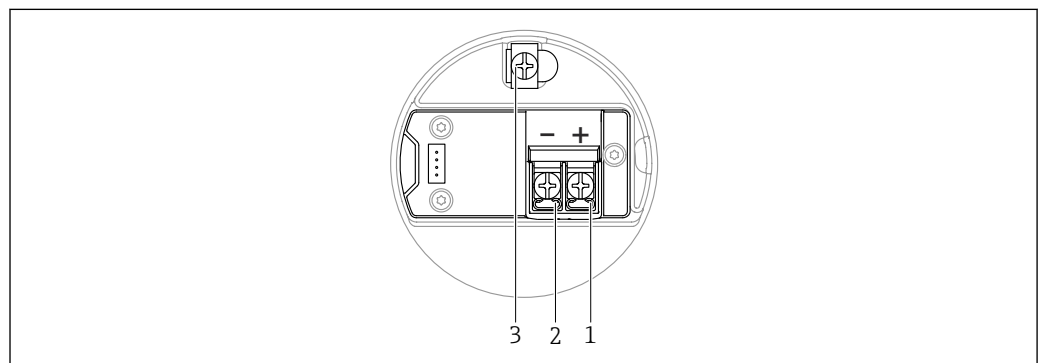

A0045842

▣ 6 Connection terminals and ground terminal in the connection compartment

- 1 Plus terminal
- 2 Minus terminal
- 3 Internal ground terminal

Terminals

- Supply voltage and inner ground terminal
Clamping range: 0.5 to 2.5 mm² (20 to 14 AWG)
- External ground terminal
Clamping range: 0.5 to 4 mm² (20 to 12 AWG)

Available device plugs

 In the case of devices with a plug, it is not necessary to open the housing for connection purposes.

Use the enclosed seals to prevent the penetration of moisture into the device.

Devices with M12 plug

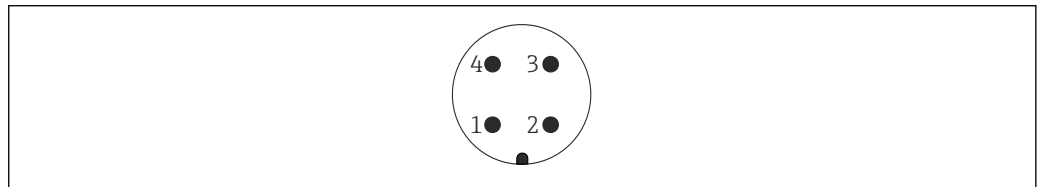

A0011175

 7 View of the plug-in connection on the device

- 1 Signal +
- 2 Not used
- 3 Signal -
- 4 Ground

Various M12 plug sockets are available as accessories for devices with M12 plugs.

Supply voltage

The supply voltage depends on the selected type of device approval

Non-hazardous, Ex d, Ex e	9 to 32 V _{DC}
Ex i	9 to 30 V _{DC}
Nominal current	14 mA
Error current FDE (Fault Disconnection Electronic)	0 mA

-  Use only suitable and certified Profibus PA components (e.g. DP/PA segment coupler) for the power supply
- FISCO/FNICO-compliant in accordance with IEC 60079-27
- The supply is not polarity-dependent

Potential equalization

The protective ground on the device must not be connected. If necessary, the potential matching line can be connected to the outer ground terminal of the housing before the device is connected.

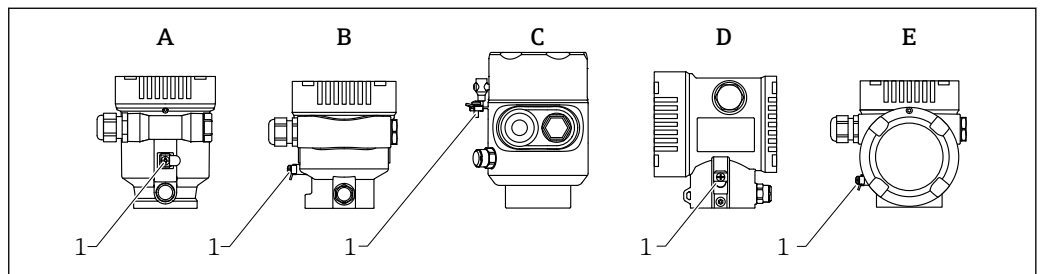

A0046583

- A Single compartment housing, plastic
- B Single compartment housing, aluminum, coated
- C Single compartment housing, 316L, hygiene (Ex device)
- D Dual compartment housing, aluminum, coated
- E Dual compartment housing, L-shaped, aluminum, coated
- 1 Ground terminal for connecting the potential matching line

⚠ WARNING**Ignitable sparks or impermissible high surface temperatures.**

Explosion hazard!

- ▶ Please refer to the separate documentation on applications in hazardous areas for the safety instructions.



For optimum electromagnetic compatibility:

- Keep potential matching line as short as possible
- Observe minimum cross-section of 2.5 mm² (14 AWG)

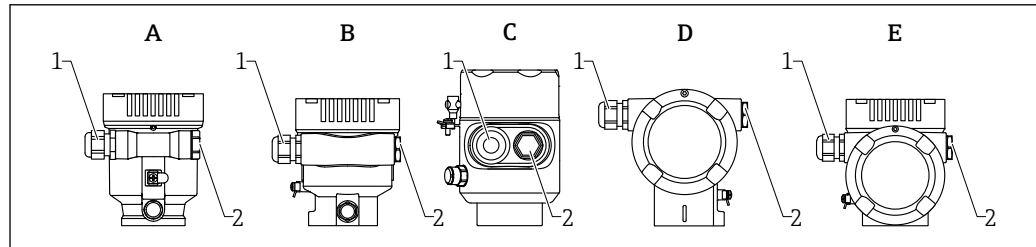
Cable entries

A0046584

- A Single compartment housing, plastic
 B Single compartment housing, aluminum, coated
 C Single compartment housing, 316L, hygiene
 D Dual compartment housing, aluminum, coated
 E Dual compartment housing, L-shaped, aluminum, coated
 1 Cable entry
 2 Dummy plug

The number and type of cable entries depend on the device version ordered.



Always route connecting cables downwards so that moisture cannot penetrate the connection compartment.

If necessary, create a drip loop or use a weather protection cover.

Cable specification**Rated cross-section**

- Supply voltage
0.5 to 2.5 mm² (20 to 13 AWG)
- Protective earth or grounding of the cable shield
> 1 mm² (17 AWG)
- External ground terminal
0.5 to 4 mm² (20 to 12 AWG)

Cable outer diameter

The cable outer diameter depends on the cable gland used

- Coupling, plastic:
ø5 to 10 mm (0.2 to 0.38 in)
- Coupling, nickel-plated brass:
ø7 to 10.5 mm (0.28 to 0.41 in)
- Coupling, stainless steel:
ø7 to 12 mm (0.28 to 0.47 in)



Use a twisted, shielded twin-core cable, preferably cable type A.

For further information on the cable specification:

- Operating Instructions BA00034S "PROFIBUS DP/PA: Guidelines for planning and commissioning"
- PROFIBUS Assembling Guideline 8.022
- IEC 61158-2 (MBP).

Overvoltage protection

The overvoltage protection can optionally be ordered as a "Mounted accessory" via the product structure.

Devices without optional overvoltage protection

The devices satisfy the IEC/DIN EN IEC 61326-1 product standard (Table 2 Industrial environment).

Depending on the type of port (DC power supply, input/output port) different testing levels according to IEC/DIN EN 61326-1 against transient overvoltages are applied (IEC/DIN EN 61000-4-5 Surge):
Test level on DC power ports and input/output ports is 1 000 V line to earth

Devices with optional overvoltage protection

- Spark-over voltage: min. 400 V_{DC}
- Tested according to IEC/DIN EN 60079-14 sub chapter 12.3 (IEC/DIN EN 60060-1 chapter 7)
- Nominal discharge current: 10 kA

NOTICE

The device can be destroyed by excessively high electrical voltages.

- ▶ Always ground the device with integrated overvoltage protection.

Overvoltage category

Overvoltage category II

Performance characteristics

Reference operating conditions

- Temperature = +24 °C (+75 °F) ±5 °C (±9 °F)
- Pressure = 960 mbar abs. (14 psia) ±100 mbar (±1.45 psi)
- Humidity = 60 % ±15 %
- Reflector: metal plate with diameter ≥ 1 m (40 in)
- No major interference reflections inside the signal beam

Maximum measured error

Reference accuracy

Accuracy

The accuracy is the sum of the non-linearity, non-repeatability and hysteresis.

- Measuring distance up to 0.8 m (2.62 ft): max. ±4 mm (±0.16 in)
- Measuring distance > 0.8 m (2.62 ft): ±1 mm (±0.04 in)

Non-repeatability

Non-repeatability is already included in the accuracy.

≤ 1 mm (0.04 in)



If conditions deviate from the reference operating conditions, the offset/zero point that results from the installation conditions can be up to ±4 mm (±0.16 in). This additional offset/zero point can be eliminated by entering a correction (**Level correction** parameter) during commissioning.

Differing values in near-range applications

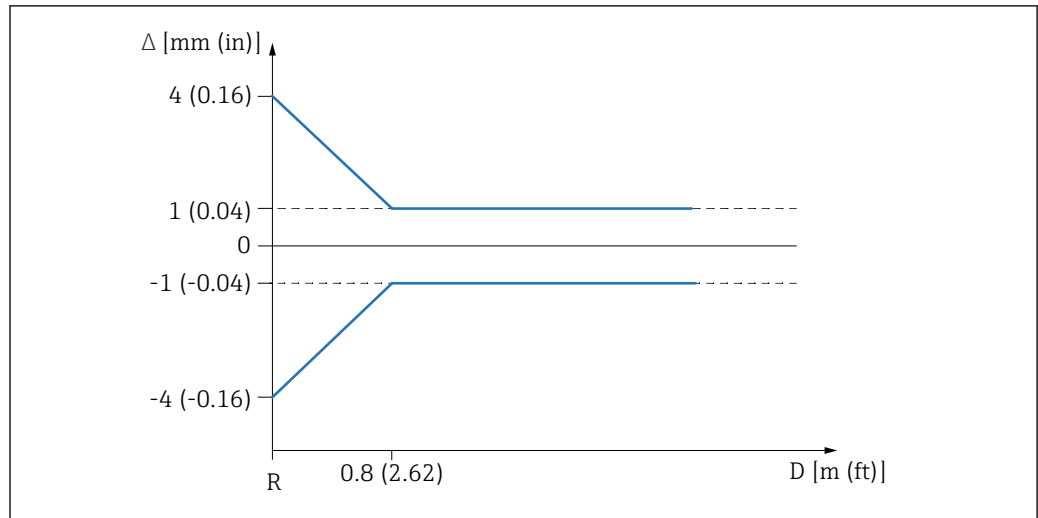

A0032636

8 Maximum measured error in near-range applications

- Δ Maximum measured error
- R Reference point of the distance measurement
- D Distance from reference point of antenna

Measured value resolution Dead band according to DIN EN IEC 61298-2/DIN EN IEC 60770-1:
Digital: 1 mm

Response time According to DIN EN IEC 61298-2 / DIN EN IEC 60770-1, the step response time is the time following an abrupt change in the input signal up until the changed output signal has adopted 90% of the steady-state value for the first time.

The response time can be configured.

The following step response times apply (in accordance with DIN EN IEC 61298-2/DIN EN IEC 60770-1) when damping is switched off:

- Pulse frequency $\geq 5/s$ (cycle time ≤ 200 ms)
- Step response time < 1 s

Influence of ambient temperature  The output changes due to the effect of the ambient temperature with respect to the reference temperature.

The measurements are carried out in accordance with DIN EN IEC 61298-3/DIN EN IEC 60770-1
Average $T_C = 2$ mm/10 K

Influence of gas phase High pressure reduces the speed of propagation of the measuring signals in the gas or vapor above the medium. This effect depends on the type of gas phase and its temperature. This results in a systematic measured error that increases with increasing distance between the reference point of the measurement (flange) and the surface of the product.

The following table shows the systematic measured error for some typical gases and vapors in relation to the distance.

Measured error for some typical gases and vapors

Gas phase	Temperature	Pressure ¹⁾		
		1 bar (14.5 psi)	10 bar (145 psi)	25 bar (362 psi)
Air Nitrogen	+20 °C (+68 °F)	0.00 %	+0.22 %	+0.58 %
	+200 °C (+392 °F)	-0.01 %	+0.13 %	+0.36 %
	+400 °C (+752 °F)	-0.02 %	+0.08 %	+0.29 %

Gas phase	Temperature	Pressure ¹⁾		
		1 bar (14.5 psi)	10 bar (145 psi)	25 bar (362 psi)
Hydrogen	+20 °C (+68 °F)	-0.01 %	+0.10 %	+0.25 %
	+200 °C (+392 °F)	-0.02 %	+0.05 %	+0.17 %
	+400 °C (+752 °F)	-0.02 %	+0.03 %	+0.11 %
Water (saturated steam)	+100 °C (+212 °F)	+0.02 %	-	-
	+180 °C (+356 °F)	-	+2.10 %	-
	+263 °C (+505 °F)	-	-	+4.15 %
	+310 °C (+590 °F)	-	-	-
	+364 °C (+687 °F)	-	-	-

1) A positive value means that the distance measured is too great

 With a known, constant pressure, it is possible to compensate for this measured error with a linearization, for example.

Installation

Mounting location

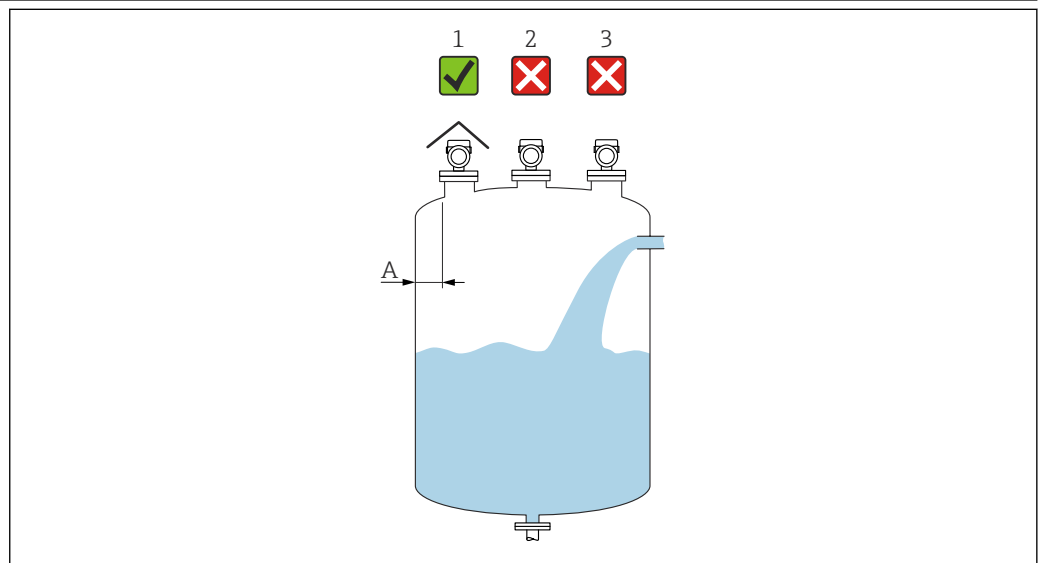

A0016882

A Recommended distance from wall to nozzle outer edge $\sim 1/6$ of the vessel diameter. However, the device must not under any circumstances be mounted closer than 15 cm (5.91 in) to the tank wall.

1 Use of a weather protection cover; protection from direct sunlight or rain

2 Installation in the center, interference can cause signal loss

3 Do not install above the filling curtain

Orientation

Internal vessel fittings

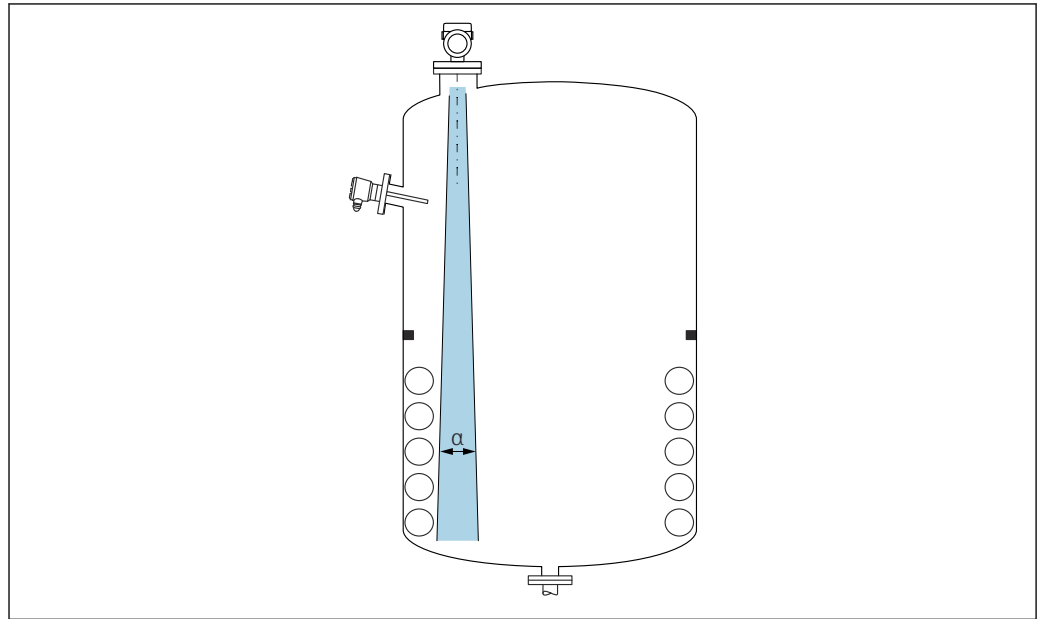

A0031777

Avoid internal fittings (level switches, temperature sensors, struts, vacuum rings, heating coils, baffles etc.) inside the signal beam. Pay attention to the beam angle α .

Avoiding interference echoes

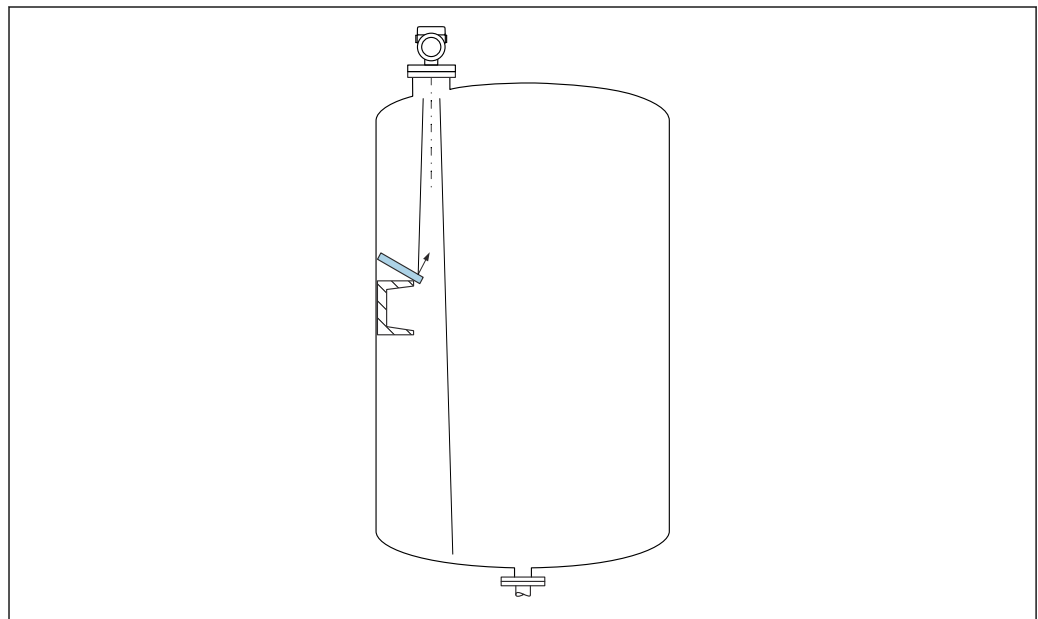

A0031813

Metal deflector plates, installed at an angle to scatter the radar signals, help prevent interference echoes.

Vertical alignment of antenna axis

Align the antenna so that it is perpendicular to the product surface.

i The maximum reach of the antenna can be reduced, or additional interference signals can occur, if the antenna is not installed perpendicular to the product.

Radial alignment of the antenna

Based on the directional characteristic, radial alignment of the antenna is not necessary.

Installation instructions

Horn antenna 65 mm (2.56 in)

Insertion hole

The diameter of the insertion hole must be larger than the outer diameter of the antenna horn of 65 mm (2.56 in)

i In the case of the 42 to 66 mm (1.65 to 2.60 in) insertion hole, the antenna horn must first be removed (e.g. process connection NPS2", DN50, 50A)

The horn is installed by guiding it from the inside through the insertion hole in the vessel and reattaching it to the process connection. The maximum permissible torque is 3 Nm.

Information about the mounting nozzle

The maximum nozzle length H_{max} depends on the nozzle diameter D .

Maximum nozzle length H_{max} as a function of the nozzle diameter D

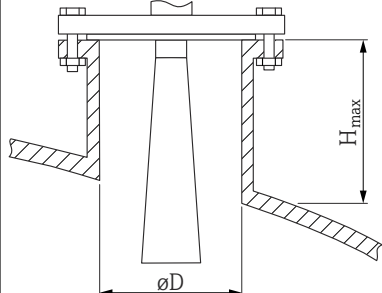
	ϕD	H_{max}
	80 to 100 mm (3.2 to 4 in)	1700 mm (67 in)
	100 to 150 mm (4 to 6 in)	2100 mm (83 in)
	≥ 150 mm (6 in)	3200 mm (126 in)

i In the case of longer nozzles, reduced measuring performance must be expected.

Please note the following:

- The end of the nozzle must be smooth and free from burrs.
- The edge of the nozzle should be rounded.
- Mapping must be performed.
- Please contact the manufacturer's support department for applications with nozzles that are higher than indicated in the table.

PTFE drip-off antenna 50 mm (2 in)

Information about the mounting nozzle

The maximum nozzle length H_{max} depends on the nozzle diameter D .

The maximum length of the nozzle H_{max} depends on the nozzle diameter D

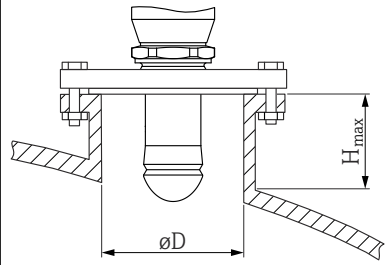
	ϕD	H_{max}
	50 to 80 mm (2 to 3.2 in)	750 mm (30 in)
	80 to 100 mm (3.2 to 4 in)	1 150 mm (46 in)
	100 to 150 mm (4 to 6 in)	1 450 mm (58 in)
	≥ 150 mm (6 in)	2 200 mm (88 in)

i In the case of longer nozzles, reduced measuring performance must be expected.

Please note the following:

- The end of the nozzle must be smooth and free from burrs.
- The edge of the nozzle should be rounded.
- Mapping must be performed.
- Please contact the manufacturer's support department for applications with nozzles that are higher than indicated in the table.

Antenna, PTFE clad, flush mount 50 mm (2 in)

Mounting cladded flanges

i Note the following for cladded flanges:

- Use the same number of flange screws as the number of flange bores provided.
- Tighten the screws with the necessary torque (see Table).
- Retighten after 24 hours or after the first temperature cycle.
- Depending on the process pressure and temperature, check and retighten the screws, where necessary, at regular intervals.

The PTFE flange cladding normally acts simultaneously as a seal between the nozzle and the device flange.

Flange size	Number of screws	Tightening torque
EN		
DN50 PN10/16	4	45 to 65 Nm
DN50 PN25/40	4	45 to 65 Nm
ASME		
NPS 2" Cl.150	4	35 to 55 Nm
NPS 2" Cl.300	8	20 to 30 Nm
JIS		
10K 50A	4	40 to 60 Nm

Information about the mounting nozzle

The maximum nozzle length H_{max} depends on the nozzle diameter D .

The maximum length of the nozzle H_{max} depends on the nozzle diameter D

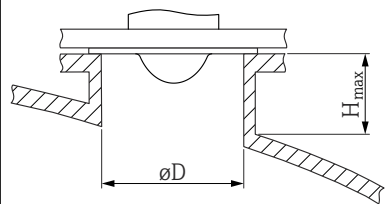
	ϕD	H_{max}
	50 to 80 mm (2 to 3.2 in)	600 mm (24 in)
	80 to 100 mm (3.2 to 4 in)	1 000 mm (40 in)

	ϕD	H_{max}
	100 to 150 mm (4 to 6 in)	1250 mm (50 in)
	≥ 150 mm (6 in)	1850 mm (74 in)

 In the case of longer nozzles, reduced measuring performance must be expected.

Please note the following:

- The end of the nozzle must be smooth and free from burrs.
- The edge of the nozzle should be rounded.
- Mapping must be performed.
- Please contact the manufacturer's support department for applications with nozzles that are higher than indicated in the table.

Antenna, PTFE clad, flush mount 80 mm (3 in)

Mounting clad flanges

 Note the following for clad flanges:

- Use the same number of flange screws as the number of flange bores provided.
- Tighten the screws with the necessary torque (see Table).
- Retighten after 24 hours or after the first temperature cycle.
- Depending on the process pressure and temperature, check and retighten the screws, where necessary, at regular intervals.

The PTFE flange cladding normally acts simultaneously as a seal between the nozzle and the device flange.

Flange size	Number of screws	Tightening torque
EN		
DN80 PN10/16	8	40 to 55 Nm
DN80 PN25/40	8	40 to 55 Nm
DN100 PN10/16	8	40 to 60 Nm
DN100 PN25/40	8	55 to 80 Nm
DN150 PN10/16	8	75 to 105 Nm
ASME		
NPS 3" Cl.150	4	65 to 95 Nm
NPS 3" Cl.300	8	40 to 55 Nm
NPS 4" Cl.150	8	45 to 65 Nm
NPS 4" Cl.300	8	55 to 80 Nm
NPS 6" Cl.150	8	85 to 125 Nm
NPS 6" Cl.300	12	60 to 85 Nm
NPS 8" Cl.150	8	115 to 170 Nm
JIS		
10K 50A	4	40 to 60 Nm
10K 80A	8	25 to 35 Nm
10K 100A	8	35 to 55 Nm
10K 150A	8	75 to 115 Nm

Information about the mounting nozzle

The maximum nozzle length H_{max} depends on the nozzle diameter D .

The maximum length of the nozzle H_{max} depends on the nozzle diameter D

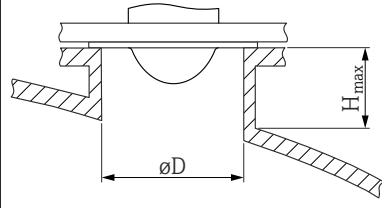
	ϕD	H_{max}
	80 to 100 mm (3.2 to 4 in)	1 750 mm (70 in)
	100 to 150 mm (4 to 6 in)	2 200 mm (88 in)
	≥ 150 mm (6 in)	3 300 mm (132 in)

i In the case of longer nozzles, reduced measuring performance must be expected.

Please note the following:

- The end of the nozzle must be smooth and free from burrs.
- The edge of the nozzle should be rounded.
- Mapping must be performed.
- Please contact the manufacturer's support department for applications with nozzles that are higher than indicated in the table.

Beam angle

The beam angle is defined as the angle α where the energy density of the radar waves reaches half the value of the maximum energy density (3 dB width). Microwaves are also emitted outside the signal beam and can be reflected off interfering installations.

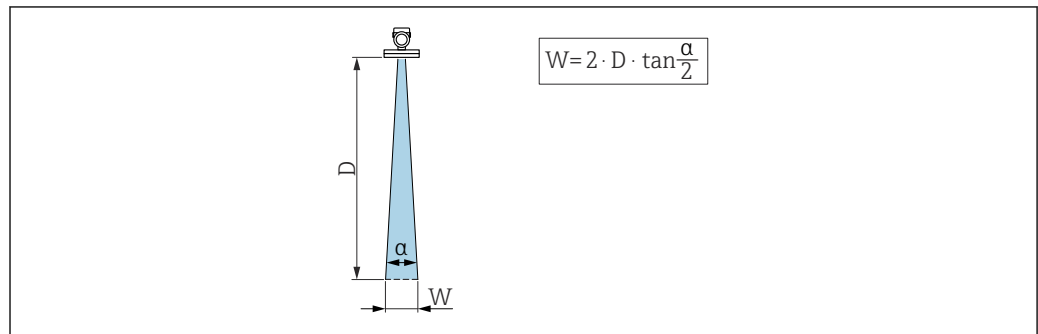

9 Relationship between beam angle α , distance D and beamwidth diameter W

i The beamwidth diameter W depends on the beam angle α and the distance D .

Horn antenna 65 mm (2.56 in), α 4 °

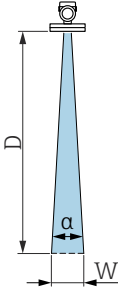
$W = D \times 0.07$	D	W
	5 m (16 ft)	0.35 m (1.15 ft)
	10 m (33 ft)	0.70 m (2.30 ft)
	15 m (49 ft)	1.05 m (3.45 ft)
	20 m (66 ft)	1.40 m (4.59 ft)
	25 m (82 ft)	1.75 m (5.74 ft)
	30 m (98 ft)	2.10 m (6.89 ft)
	35 m (115 ft)	2.45 m (8.04 ft)
	40 m (131 ft)	2.80 m (9.19 ft)
	45 m (148 ft)	3.15 m (10.33 ft)
	50 m (164 ft)	3.50 m (11.48 ft)
	80 m (262 ft)	5.60 m (18.37 ft)

Drip-off antenna, PTFE 50 mm (2 in), $\alpha = 6^\circ$

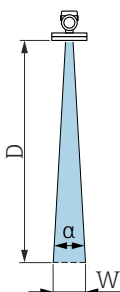
$W = D \times 0.10$	D	W
	5 m (16 ft)	0.52 m (1.70 ft)
	10 m (33 ft)	1.04 m (3.41 ft)
	15 m (49 ft)	1.56 m (5.12 ft)
	20 m (66 ft)	2.08 m (6.82 ft)
	25 m (82 ft)	2.60 m (8.53 ft)
	30 m (98 ft)	3.12 m (10.24 ft)
	35 m (115 ft)	3.64 m (11.94 ft)
	40 m (131 ft)	4.16 m (13.65 ft)
	45 m (148 ft)	4.68 m (15.35 ft)
	50 m (164 ft)	5.20 m (17.06 ft)

Antenna, PTFE clad, flush mount 50 mm (2 in), $\alpha = 7^\circ$

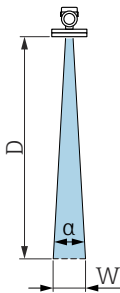
$W = D \times 0.12$	D	W
	5 m (16 ft)	0.61 m (2.00 ft)
	10 m (33 ft)	1.22 m (4.00 ft)
	15 m (49 ft)	1.83 m (6.00 ft)
	20 m (66 ft)	2.44 m (8.01 ft)
	25 m (82 ft)	3.05 m (10.01 ft)
	30 m (98 ft)	3.66 m (12.01 ft)
	35 m (115 ft)	4.27 m (14.01 ft)
	40 m (131 ft)	4.88 m (16.01 ft)
	45 m (148 ft)	5.50 m (18.04 ft)
	50 m (164 ft)	6.11 m (20.05 ft)

Antenna, PTFE clad, flush mount 80 mm (3 in), $\alpha = 3^\circ$

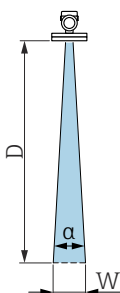
$W = D \times 0.05$	D	W
	5 m (16 ft)	0.25 m (0.82 ft)
	10 m (33 ft)	0.50 m (1.64 ft)
	15 m (49 ft)	0.75 m (2.46 ft)
	20 m (66 ft)	1.00 m (3.28 ft)
	25 m (82 ft)	1.25 m (4.10 ft)
	30 m (98 ft)	1.50 m (4.92 ft)
	35 m (115 ft)	1.75 m (5.74 ft)
	40 m (131 ft)	2.00 m (6.56 ft)
	45 m (148 ft)	2.25 m (7.38 ft)
	50 m (164 ft)	2.50 m (8.20 ft)
	60 m (197 ft)	3.00 m (9.84 ft)
	70 m (230 ft)	3.50 m (11.48 ft)
	80 m (262 ft)	4.00 m (13.12 ft)

Special mounting instructions

Measurement through a ball valve

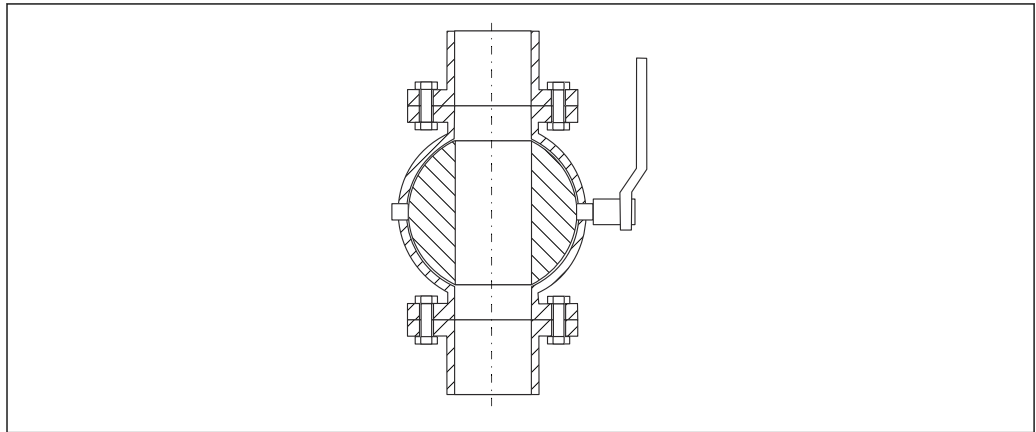

- Measurements can be performed through an open full bore ball valve without any problems.
- At the transitions, no gap exceeding 1 mm (0.04 in) may be left.
- Opening diameter of ball valve must always correspond to the pipe diameter; avoid edges and constrictions.

Installation in stilling well

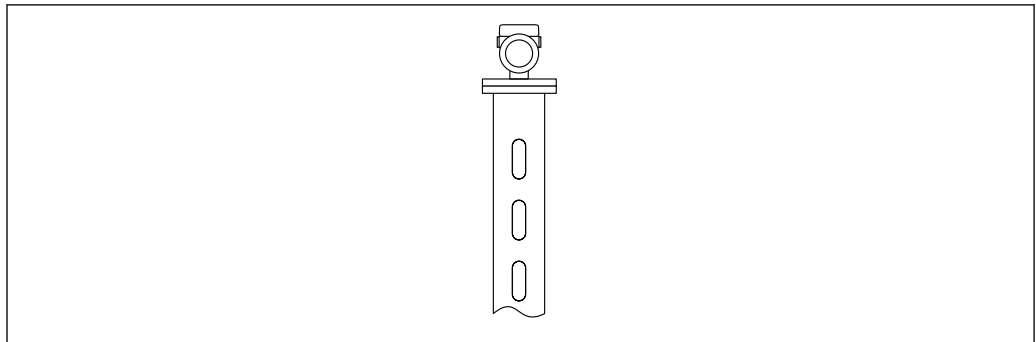

 10 Installation in stilling well

-  Measurements can be performed through an open full bore ball valve without any problems.

Recommendations for the stilling well

- Metal (no enamel liner; plastic liner on request)
- Constant diameter
- Difference in diameter between antenna and inner diameter of the stilling well as small as possible
- Weld seam as even as possible
- Slot width or diameter of boreholes maximum 1/10 of pipe diameter, deburred
The length and number do not affect the measurement
- Select an antenna that is as big as possible
Recommendation, use 80 mm (3 in) antenna
- At transition points, e.g. when a ball valve is used or individual pipe segments are joined, any gaps that occur should not exceed 1 mm (0.04 in)
- The inside of the stilling well must be smooth
 - Use an extruded or parallel-welded metal pipe as the measuring pipe
 - The pipe can be extended with welding neck flanges or pipe sleeves
 - Flush-align the flange and pipe properly on the inside
-  Do not weld through the pipe wall. The inside of the stilling well must remain smooth. If the pipe is welded through unintentionally, carefully remove and smoothen any weld seams and unevenness on the inside, as otherwise this will cause strong interference echoes and encourage material buildup.

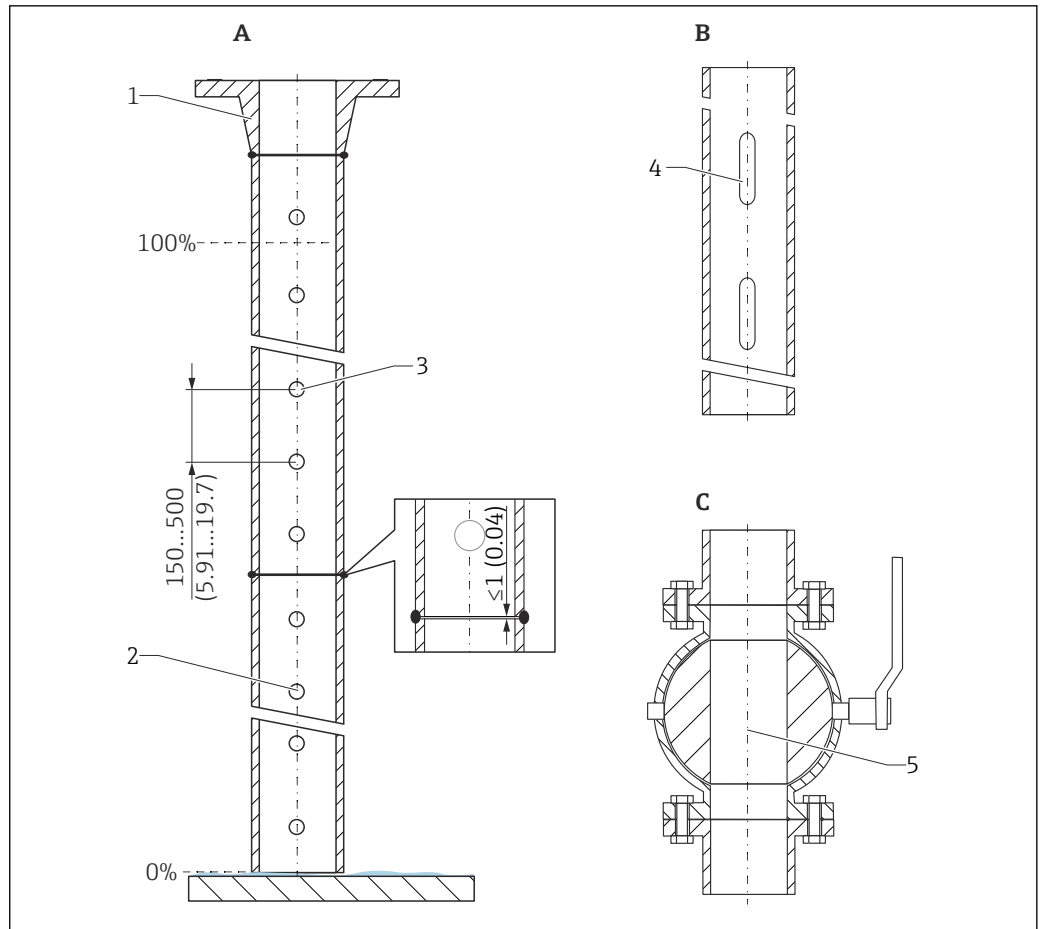

A0046559

11 Example of stilling well design. Unit of measurement mm (in)

A Stilling well with holes; example for flush mount antenna 80 mm (3 in)

B Stilling well with slots

C Full bore ball valve

1 e.g. welding neck flange DIN2633

2 Borehole always deburred

3 Borehole diameter maximum 1/10 of the pipe diameter; borehole on one side or drilled through

4 Slot width maximum 1/10 of the pipe diameter; slot on one side or drilled through

5 Opening diameter of ball valve must always correspond to the pipe diameter, avoid edges and constrictions

Installation in the bypass

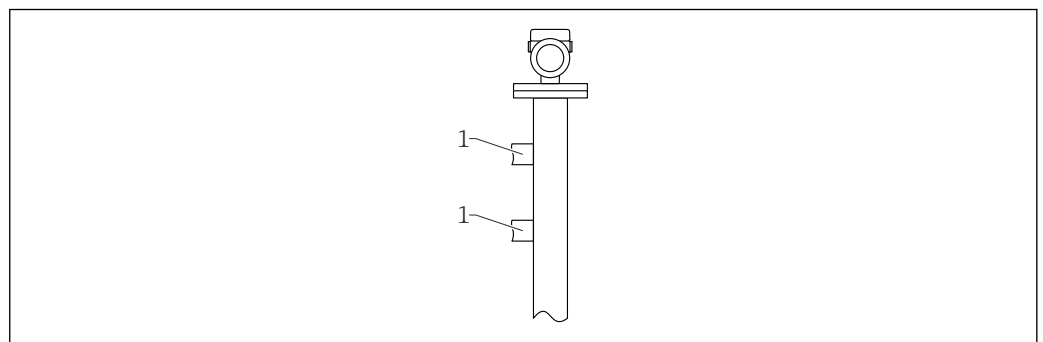

A0046560

12 Installation in the bypass

1 Tank connectors

 Measurements can be performed through an open full bore ball valve without any problems.

Recommendations for the bypass

- Metal (no plastic or enamel liner)
- Constant diameter
- Select an antenna that is as big as possible; recommendation, use 80 mm (3 in)
- Difference in diameter between antenna and inner diameter of the bypass as small as possible
- At transition points, e.g. when a ball valve is used or individual pipe segments are joined, any gaps that occur should not exceed 1 mm (0.04 in)

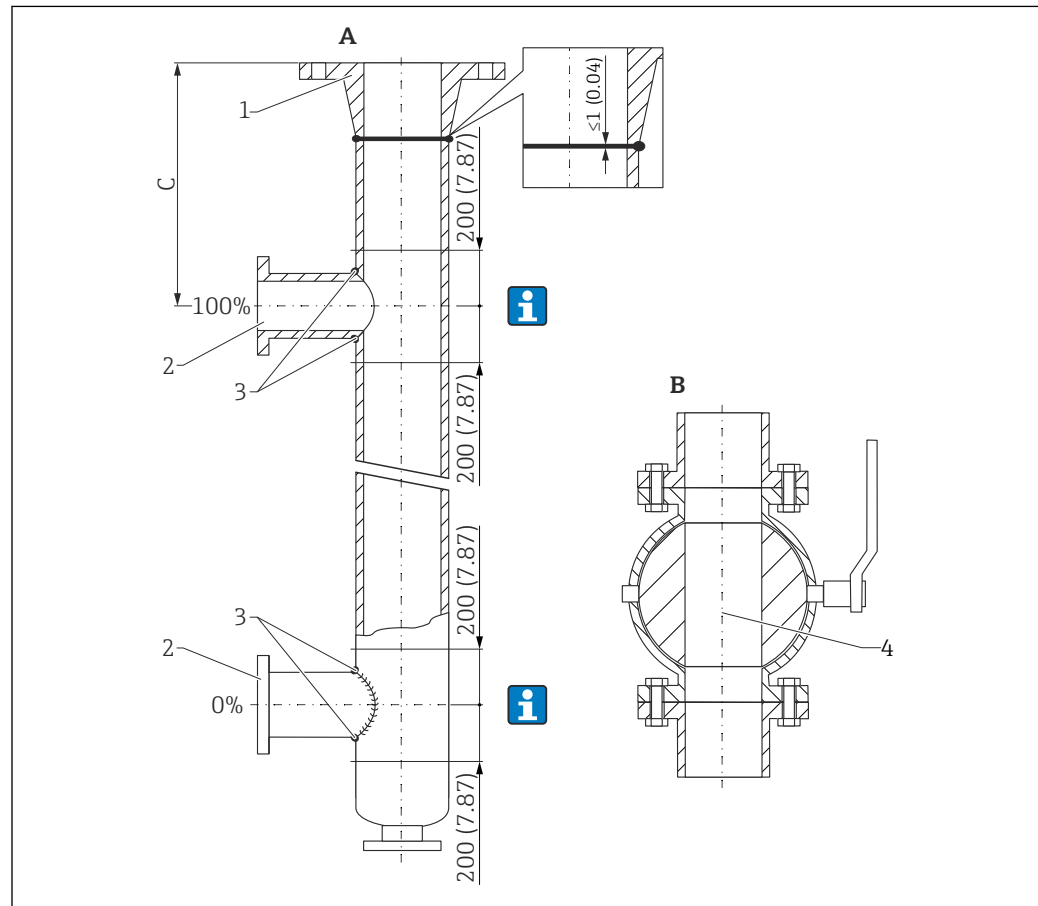

13 Example of bypass design. Unit of measurement mm (in)

- A Example for flush mount antenna 80 mm (3 in)
 B Full bore ball valve
 C Minimum distance to upper connection pipe: 400 mm (15.7 in)
 1 e.g. welding neck flange DIN2633
 2 Diameter of connecting pipes as small as possible
 3 Do not weld through the pipe wall; the inside of the pipe must remain smooth
 4 Opening diameter of ball valve must always correspond to the pipe diameter, avoid edges and constrictions

i In the area of the tank connection pieces ($\sim \pm 20$ cm (± 7.87 in)), reduced measurement accuracy can be expected.

External measurement through plastic cover or dielectric windows

- Dielectric constant of medium: $\epsilon_r \geq 10$
- The distance from the tip of the antenna to the tank should be approx. 100 mm (4 in).
- Avoid installation positions where condensate or buildup can form between the antenna and the vessel
- In the case of outdoor installations, ensure that the area between the antenna and the tank is protected from the weather
- Do not install any fittings or attachments between the antenna and the tank that could reflect the signal

The thickness of the tank ceiling or the dielectric window depends on the ϵ_r of the material.

The material thickness can be a full multiple of the optimum thickness (table); it is important to note, however, that the microwave transparency decreases significantly with increasing material thickness.

Optimum material thickness

Material	Optimum material thickness
PE; ϵ_r 2.3	1.25 mm (0.049 in)
PTFE; ϵ_r 2.1	1.30 mm (0.051 in)
PP; ϵ_r 2.3	1.25 mm (0.049 in)
Perspex; ϵ_r 3.1	1.10 mm (0.043 in)

Container with heat insulation

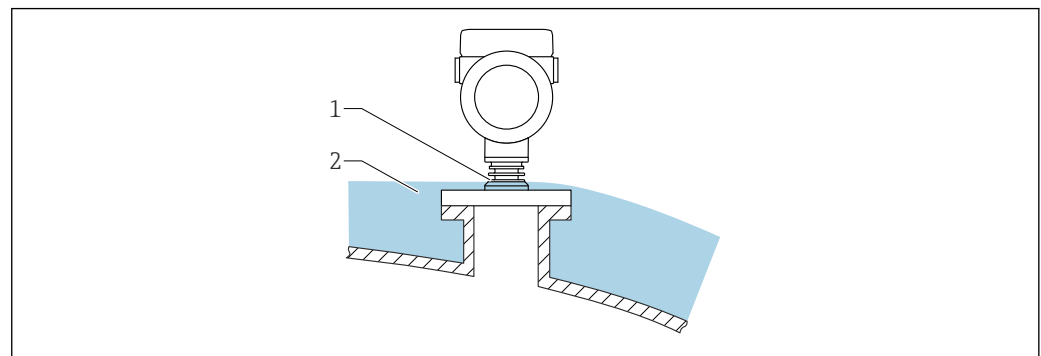

A0046566

If process temperatures are high, the device should be included in the usual container insulation system (2) to prevent the electronics from heating as a result of thermal radiation or convection. The rib structure (1) must not be insulated.

Environment

- Ambient temperature range** The following values apply up to a process temperature of +85 °C (+185 °F). At higher process temperatures, the permitted ambient temperature is reduced.
- Without LCD display:
Standard: -40 to +85 °C (-40 to +185 °F)
 - With LCD display: -40 to +85 °C (-40 to +185 °F) with limitations in optical properties such as display speed and contrast for example. Can be used without limitations up to -20 to +60 °C (-4 to +140 °F)
- i** If operating outdoors in strong sunlight:
- Mount the device in the shade.
 - Avoid direct sunlight, particularly in warm climatic regions.
 - Use a weather protection cover (see accessories).

Ambient temperature limits The permitted ambient temperature (T_a) depends on the selected housing material (Product Configurator → Housing; Material →) and the selected process temperature range (Product Configurator → Application →).

In the event of temperature (T_p) at the process connection, the permitted ambient temperature (T_a) is reduced.

i The following information only takes functional aspects into consideration. Additional restrictions may apply for certified device versions.

Plastic housing

Plastic housing; process temperature -20 to $+150$ °C (-4 to $+302$ °F)

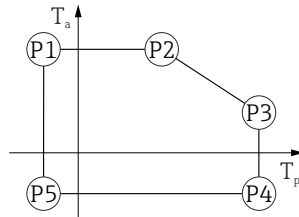

A0032024

▣ 14 Plastic housing; process temperature -20 to $+150$ °C (-4 to $+302$ °F)

- P1 = T_p : -20 °C (-4 °F) | T_a : $+76$ °C ($+169$ °F)
- P2 = T_p : $+76$ °C ($+169$ °F) | T_a : $+76$ °C ($+169$ °F)
- P3 = T_p : $+150$ °C ($+302$ °F) | T_a : $+25$ °C ($+77$ °F)
- P4 = T_p : $+150$ °C ($+302$ °F) | T_a : -20 °C (-4 °F)
- P5 = T_p : -20 °C (-4 °F) | T_a : -20 °C (-4 °F)

i In the case of devices with a plastic housing and CSA C/US approval, the selected process temperature of -20 to $+150$ °C (-4 to $+302$ °F) is limited to 0 to $+150$ °C ($+32$ to $+302$ °F).

Restriction to a process temperature of 0 to $+150$ °C ($+32$ to $+302$ °F) with CSA C/US approval and plastic housing

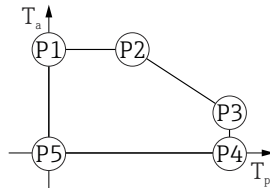

A0048826

▣ 15 Plastic housing; process temperature 0 to $+150$ °C ($+32$ to $+302$ °F) with CSA C/US approval

- P1 = T_p : 0 °C ($+32$ °F) | T_a : $+76$ °C ($+169$ °F)
- P2 = T_p : $+76$ °C ($+169$ °F) | T_a : $+76$ °C ($+169$ °F)
- P3 = T_p : $+150$ °C ($+302$ °F) | T_a : $+25$ °C ($+77$ °F)
- P4 = T_p : $+150$ °C ($+302$ °F) | T_a : 0 °C ($+32$ °F)
- P5 = T_p : 0 °C ($+32$ °F) | T_a : 0 °C ($+32$ °F)

Plastic housing; process temperature -20 to $+200$ °C (-4 to $+392$ °F)

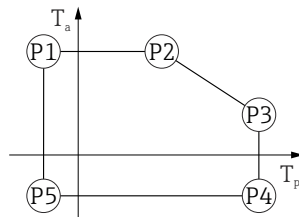

A0032024

▣ 16 Plastic housing; process temperature -20 to $+200$ °C (-4 to $+392$ °F)

- P1 = T_p : -20 °C (-4 °F) | T_a : $+76$ °C ($+169$ °F)
- P2 = T_p : $+76$ °C ($+169$ °F) | T_a : $+76$ °C ($+169$ °F)
- P3 = T_p : $+200$ °C ($+392$ °F) | T_a : $+27$ °C ($+81$ °F)
- P4 = T_p : $+200$ °C ($+392$ °F) | T_a : -20 °C (-4 °F)
- P5 = T_p : -20 °C (-4 °F) | T_a : -20 °C (-4 °F)

i In the case of devices with a plastic housing and CSA C/US approval, the selected process temperature of -20 to $+200$ °C (-4 to $+392$ °F) is limited to 0 to $+200$ °C ($+32$ to $+392$ °F).

Restriction to a process temperature of 0 to +200 °C (+32 to +392 °F) with CSA C/US approval and plastic housing

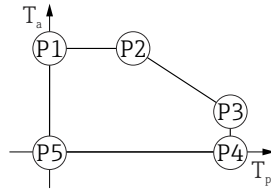

A0048826

17 Plastic housing; process temperature 0 to +200 °C (+32 to +392 °F) with CSA C/US approval

- P1 = T_p : 0 °C (+32 °F) | T_a : +76 °C (+169 °F)
- P2 = T_p : +76 °C (+169 °F) | T_a : +76 °C (+169 °F)
- P3 = T_p : +200 °C (+392 °F) | T_a : +27 °C (+81 °F)
- P4 = T_p : +200 °C (+392 °F) | T_a : 0 °C (+32 °F)
- P5 = T_p : 0 °C (+32 °F) | T_a : 0 °C (+32 °F)

Plastic housing; process temperature -40 to +150 °C (-40 to +302 °F)

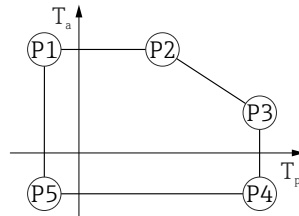

A0032024

18 Plastic housing; process temperature -40 to +150 °C (-40 to +302 °F)

- P1 = T_p : -40 °C (-40 °F) | T_a : +76 °C (+169 °F)
- P2 = T_p : +76 °C (+169 °F) | T_a : +76 °C (+169 °F)
- P3 = T_p : +150 °C (+302 °F) | T_a : +25 °C (+77 °F)
- P4 = T_p : +150 °C (+302 °F) | T_a : -40 °C (-40 °F)
- P5 = T_p : -40 °C (-40 °F) | T_a : -40 °C (-40 °F)

i In the case of devices with a plastic housing and CSA C/US approval, the selected process temperature of -40 to +150 °C (-40 to +302 °F) is limited to 0 to +150 °C (+32 to +302 °F).

Restriction to a process temperature of 0 to +150 °C (+32 to +302 °F) with CSA C/US approval and plastic housing

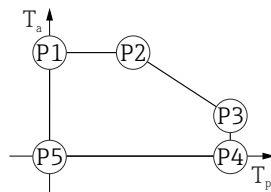

A0048826

19 Plastic housing; process temperature 0 to +150 °C (+32 to +302 °F) with CSA C/US approval

- P1 = T_p : 0 °C (+32 °F) | T_a : +76 °C (+169 °F)
- P2 = T_p : +76 °C (+169 °F) | T_a : +76 °C (+169 °F)
- P3 = T_p : +150 °C (+302 °F) | T_a : +25 °C (+77 °F)
- P4 = T_p : +150 °C (+302 °F) | T_a : 0 °C (+32 °F)
- P5 = T_p : 0 °C (+32 °F) | T_a : 0 °C (+32 °F)

Plastic housing; process temperature -40 to $+200$ °C (-40 to $+392$ °F)

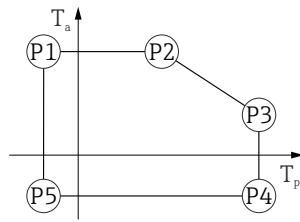

A0032024

▣ 20 Plastic housing; process temperature -40 to $+200$ °C (-40 to $+392$ °F)

P1 = T_p : -40 °C (-40 °F) | T_a : $+76$ °C ($+169$ °F)

P2 = T_p : $+76$ °C ($+169$ °F) | T_a : $+76$ °C ($+169$ °F)

P3 = T_p : $+200$ °C ($+392$ °F) | T_a : $+27$ °C ($+81$ °F)

P4 = T_p : $+200$ °C ($+392$ °F) | T_a : -40 °C (-40 °F)

P5 = T_p : -40 °C (-40 °F) | T_a : -40 °C (-40 °F)

i In the case of devices with a plastic housing and CSA C/US approval, the selected process temperature of -40 to $+200$ °C (-40 to $+392$ °F) is limited to 0 to $+200$ °C ($+32$ to $+392$ °F).

Restriction to a process temperature of 0 to $+200$ °C ($+32$ to $+392$ °F) with CSA C/US approval and plastic housing

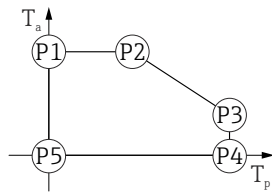

A0048626

▣ 21 Plastic housing; process temperature 0 to $+200$ °C ($+32$ to $+392$ °F) with CSA C/US approval

P1 = T_p : 0 °C ($+32$ °F) | T_a : $+76$ °C ($+169$ °F)

P2 = T_p : $+76$ °C ($+169$ °F) | T_a : $+76$ °C ($+169$ °F)

P3 = T_p : $+200$ °C ($+392$ °F) | T_a : $+27$ °C ($+81$ °F)

P4 = T_p : $+200$ °C ($+392$ °F) | T_a : 0 °C ($+32$ °F)

P5 = T_p : 0 °C ($+32$ °F) | T_a : 0 °C ($+32$ °F)

Plastic housing; process temperature -40 to $+280$ °C (-40 to $+536$ °F)

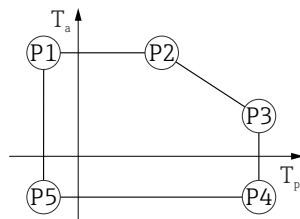

A0032024

▣ 22 Plastic housing; process temperature -40 to $+280$ °C (-40 to $+536$ °F)

P1 = T_p : -40 °C (-40 °F) | T_a : $+76$ °C ($+169$ °F)

P2 = T_p : $+76$ °C ($+169$ °F) | T_a : $+76$ °C ($+169$ °F)

P3 = T_p : $+280$ °C ($+536$ °F) | T_a : $+48$ °C ($+118$ °F)

P4 = T_p : $+280$ °C ($+536$ °F) | T_a : -40 °C (-40 °F)

P5 = T_p : -40 °C (-40 °F) | T_a : -40 °C (-40 °F)

i In the case of devices with a plastic housing and CSA C/US approval, the selected process temperature of -40 to $+280$ °C (-40 to $+536$ °F) is limited to 0 to $+280$ °C ($+32$ to $+536$ °F).

Restriction to a process temperature of 0 to +280 °C (+32 to +536 °F) with CSA C/US approval and plastic housing

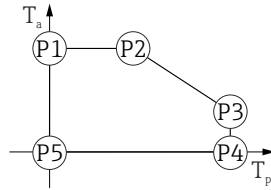

A0048826

23 Plastic housing; process temperature 0 to +280 °C (+32 to +536 °F) with CSA C/US approval

- P1 = T_p : 0 °C (+32 °F) | T_a : +76 °C (+169 °F)
- P2 = T_p : +76 °C (+169 °F) | T_a : +76 °C (+169 °F)
- P3 = T_p : +280 °C (+536 °F) | T_a : +48 °C (+118 °F)
- P4 = T_p : +280 °C (+536 °F) | T_a : 0 °C (+32 °F)
- P5 = T_p : 0 °C (+32 °F) | T_a : 0 °C (+32 °F)

Plastic housing; process temperature -40 to +450 °C (-40 to +842 °F)

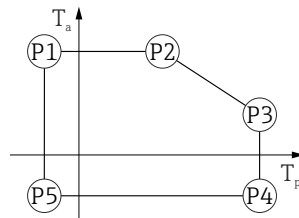

A0032024

24 Plastic housing; process temperature -40 to +450 °C (-40 to +842 °F)

- P1 = T_p : -40 °C (-40 °F) | T_a : +76 °C (+169 °F)
- P2 = T_p : +76 °C (+169 °F) | T_a : +76 °C (+169 °F)
- P3 = T_p : +450 °C (+842 °F) | T_a : +20 °C (+68 °F)
- P4 = T_p : +450 °C (+842 °F) | T_a : -40 °C (-40 °F)
- P5 = T_p : -40 °C (-40 °F) | T_a : -40 °C (-40 °F)

i In the case of devices with a plastic housing and CSA C/US approval, the selected process temperature of -40 to +450 °C (-40 to +842 °F) is limited to 0 to +450 °C (+32 to +842 °F).

Restriction to a process temperature of 0 to +450 °C (+32 to +842 °F) with CSA C/US approval and plastic housing

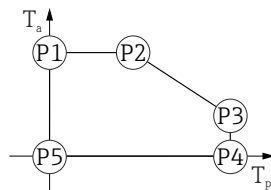

A0048826

25 Plastic housing; process temperature 0 to +450 °C (+32 to +842 °F) with CSA C/US approval

- P1 = T_p : 0 °C (+32 °F) | T_a : +76 °C (+169 °F)
- P2 = T_p : +76 °C (+169 °F) | T_a : +76 °C (+169 °F)
- P3 = T_p : +450 °C (+842 °F) | T_a : +20 °C (+68 °F)
- P4 = T_p : +450 °C (+842 °F) | T_a : 0 °C (+32 °F)
- P5 = T_p : 0 °C (+32 °F) | T_a : 0 °C (+32 °F)

Plastic housing; process temperature -60 to $+150$ °C (-76 to $+302$ °F)

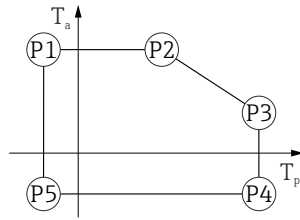

A0032024

▣ 26 Plastic housing; process temperature -60 to $+150$ °C (-76 to $+302$ °F)

- P1 = T_p : -60 °C (-76 °F) | T_a : $+76$ °C ($+169$ °F)
- P2 = T_p : $+76$ °C ($+169$ °F) | T_a : $+76$ °C ($+169$ °F)
- P3 = T_p : $+150$ °C ($+302$ °F) | T_a : $+25$ °C ($+77$ °F)
- P4 = T_p : $+150$ °C ($+302$ °F) | T_a : -60 °C (-76 °F)
- P5 = T_p : -60 °C (-76 °F) | T_a : -60 °C (-76 °F)

i In the case of devices with a plastic housing and CSA C/US approval, the selected process temperature of -60 to $+150$ °C (-76 to $+302$ °F) is limited to 0 to $+150$ °C ($+32$ to $+302$ °F).

Restriction to a process temperature of 0 to $+150$ °C ($+32$ to $+302$ °F) with CSA C/US approval and plastic housing

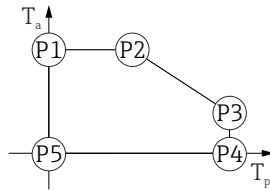

A0048626

▣ 27 Plastic housing; process temperature 0 to $+150$ °C ($+32$ to $+302$ °F) with CSA C/US approval

- P1 = T_p : 0 °C ($+32$ °F) | T_a : $+76$ °C ($+169$ °F)
- P2 = T_p : $+76$ °C ($+169$ °F) | T_a : $+76$ °C ($+169$ °F)
- P3 = T_p : $+150$ °C ($+302$ °F) | T_a : $+25$ °C ($+77$ °F)
- P4 = T_p : $+150$ °C ($+302$ °F) | T_a : 0 °C ($+32$ °F)
- P5 = T_p : 0 °C ($+32$ °F) | T_a : 0 °C ($+32$ °F)

Plastic housing; process temperature -196 to $+200$ °C (-320 to $+392$ °F)

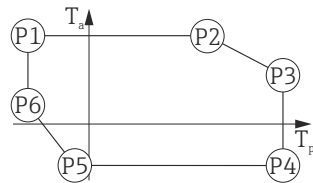

A0050248

▣ 28 Plastic housing; process temperature -196 to $+200$ °C (-320 to $+392$ °F)

- P1 = T_p : -196 °C (-320 °F) | T_a : $+76$ °C ($+169$ °F)
- P2 = T_p : $+76$ °C ($+169$ °F) | T_a : $+76$ °C ($+169$ °F)
- P3 = T_p : $+200$ °C ($+392$ °F) | T_a : $+27$ °C ($+81$ °F)
- P4 = T_p : $+200$ °C ($+392$ °F) | T_a : -40 °C (-40 °F)
- P5 = T_p : -40 °C (-40 °F) | T_a : -40 °C (-40 °F)
- P6 = T_p : -196 °C (-320 °F) | T_a : $+30$ °C ($+86$ °F)

i In the case of devices with a plastic housing and CSA C/US approval, the selected process temperature of -196 to $+200$ °C (-320 to $+392$ °F) is limited to 0 to $+200$ °C ($+32$ to $+392$ °F).

Restriction to a process temperature of 0 to +200 °C (+32 to +392 °F) with CSA C/US approval and plastic housing

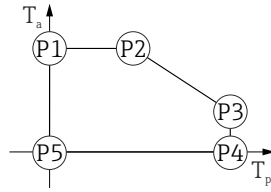

A0048826

▣ 29 CSA C/US approval and plastic housing; process temperature 0 to +200 °C (+32 to +392 °F)

- P1 = $T_p: 0\text{ °C (+32 °F)}$ | $T_a: +76\text{ °C (+169 °F)}$
- P2 = $T_p: +76\text{ °C (+169 °F)}$ | $T_a: +76\text{ °C (+169 °F)}$
- P3 = $T_p: +200\text{ °C (+392 °F)}$ | $T_a: +27\text{ °C (+81 °F)}$
- P4 = $T_p: +200\text{ °C (+392 °F)}$ | $T_a: 0\text{ °C (+32 °F)}$
- P5 = $T_p: 0\text{ °C (+32 °F)}$ | $T_a: 0\text{ °C (+32 °F)}$

Aluminum housing, coated

Aluminum housing; process temperature -20 to +150 °C (-4 to +302 °F)

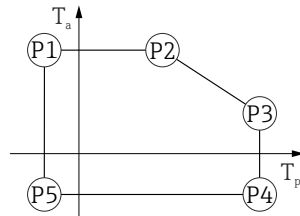

A0032024

▣ 30 Aluminum housing, coated; process temperature -20 to +150 °C (-4 to +302 °F)

- P1 = $T_p: -20\text{ °C (-4 °F)}$ | $T_a: +79\text{ °C (+174 °F)}$
- P2 = $T_p: +79\text{ °C (+174 °F)}$ | $T_a: +79\text{ °C (+174 °F)}$
- P3 = $T_p: +150\text{ °C (+302 °F)}$ | $T_a: +53\text{ °C (+127 °F)}$
- P4 = $T_p: +150\text{ °C (+302 °F)}$ | $T_a: -20\text{ °C (-4 °F)}$
- P5 = $T_p: -20\text{ °C (-4 °F)}$ | $T_a: -20\text{ °C (-4 °F)}$

Aluminum housing; process temperature -20 to +200 °C (-4 to +392 °F)

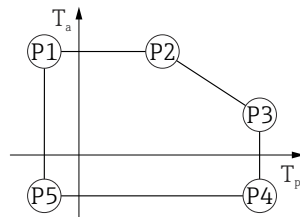

A0032024

▣ 31 Aluminum housing, coated; process temperature -20 to +200 °C (-4 to +392 °F)

- P1 = $T_p: -20\text{ °C (-4 °F)}$ | $T_a: +79\text{ °C (+174 °F)}$
- P2 = $T_p: +79\text{ °C (+174 °F)}$ | $T_a: +79\text{ °C (+174 °F)}$
- P3 = $T_p: +200\text{ °C (+392 °F)}$ | $T_a: +47\text{ °C (+117 °F)}$
- P4 = $T_p: +200\text{ °C (+392 °F)}$ | $T_a: -20\text{ °C (-4 °F)}$
- P5 = $T_p: -20\text{ °C (-4 °F)}$ | $T_a: -20\text{ °C (-4 °F)}$

Aluminum housing; process temperature -40 to $+150$ °C (-40 to $+302$ °F)

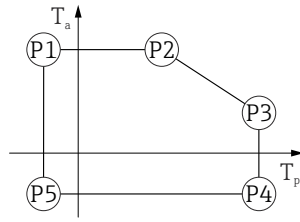

A0032024

▣ 32 Aluminum housing, coated; process temperature -40 to $+150$ °C (-40 to $+302$ °F)

- P1 = T_p : -40 °C (-40 °F) | T_a : $+79$ °C ($+174$ °F)
- P2 = T_p : $+79$ °C ($+174$ °F) | T_a : $+79$ °C ($+174$ °F)
- P3 = T_p : $+150$ °C ($+302$ °F) | T_a : $+53$ °C ($+127$ °F)
- P4 = T_p : $+150$ °C ($+302$ °F) | T_a : -40 °C (-40 °F)
- P5 = T_p : -40 °C (-40 °F) | T_a : -40 °C (-40 °F)

Aluminum housing; process temperature -40 to $+200$ °C (-40 to $+392$ °F)

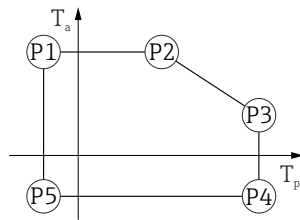

A0032024

▣ 33 Aluminum housing, coated; process temperature -40 to $+200$ °C (-40 to $+392$ °F)

- P1 = T_p : -40 °C (-40 °F) | T_a : $+79$ °C ($+174$ °F)
- P2 = T_p : $+79$ °C ($+174$ °F) | T_a : $+79$ °C ($+174$ °F)
- P3 = T_p : $+200$ °C ($+392$ °F) | T_a : $+47$ °C ($+117$ °F)
- P4 = T_p : $+200$ °C ($+392$ °F) | T_a : -40 °C (-40 °F)
- P5 = T_p : -40 °C (-40 °F) | T_a : -40 °C (-40 °F)

Aluminum housing; process temperature -40 to $+280$ °C (-40 to $+536$ °F)

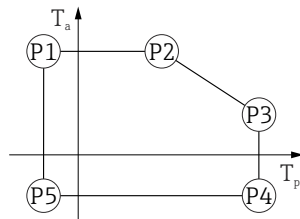

A0032024

▣ 34 Aluminum housing, coated; process temperature -40 to $+280$ °C (-40 to $+536$ °F)

- P1 = T_p : -40 °C (-40 °F) | T_a : $+79$ °C ($+174$ °F)
- P2 = T_p : $+79$ °C ($+174$ °F) | T_a : $+79$ °C ($+174$ °F)
- P3 = T_p : $+280$ °C ($+536$ °F) | T_a : $+59$ °C ($+138$ °F)
- P4 = T_p : $+280$ °C ($+536$ °F) | T_a : -40 °C (-40 °F)
- P5 = T_p : -40 °C (-40 °F) | T_a : -40 °C (-40 °F)

Aluminum housing; process temperature -40 to $+450$ °C (-40 to $+842$ °F)

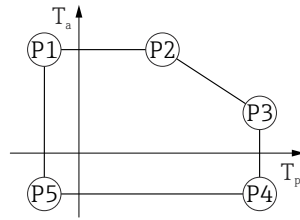

A0032024

35 Aluminum housing, coated; process temperature -40 to $+450$ °C (-40 to $+842$ °F)

- P1 = $T_p: -40$ °C (-40 °F) | $T_a: +79$ °C ($+174$ °F)
- P2 = $T_p: +79$ °C ($+174$ °F) | $T_a: +79$ °C ($+174$ °F)
- P3 = $T_p: +450$ °C ($+842$ °F) | $T_a: +39$ °C ($+102$ °F)
- P4 = $T_p: +450$ °C ($+842$ °F) | $T_a: -40$ °C (-40 °F)
- P5 = $T_p: -40$ °C (-40 °F) | $T_a: -40$ °C (-40 °F)

Aluminum housing; process temperature -60 to $+150$ °C (-76 to $+302$ °F)

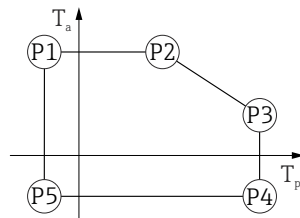

A0032024

36 Aluminum housing, coated; process temperature -60 to $+150$ °C (-76 to $+302$ °F)

- P1 = $T_p: -60$ °C (-76 °F) | $T_a: +79$ °C ($+174$ °F)
- P2 = $T_p: +79$ °C ($+174$ °F) | $T_a: +79$ °C ($+174$ °F)
- P3 = $T_p: +150$ °C ($+302$ °F) | $T_a: +53$ °C ($+127$ °F)
- P4 = $T_p: +150$ °C ($+302$ °F) | $T_a: -60$ °C (-76 °F)
- P5 = $T_p: -60$ °C (-76 °F) | $T_a: -60$ °C (-76 °F)

Aluminum housing; process temperature -196 to $+200$ °C (-320 to $+392$ °F)

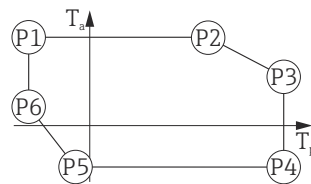

A0050248

37 Aluminum housing, coated; process temperature -196 to $+200$ °C (-320 to $+392$ °F)

- P1 = $T_p: -196$ °C (-320 °F) | $T_a: +79$ °C ($+174$ °F)
- P2 = $T_p: +79$ °C ($+174$ °F) | $T_a: +79$ °C ($+174$ °F)
- P3 = $T_p: +200$ °C ($+392$ °F) | $T_a: +47$ °C ($+117$ °F)
- P4 = $T_p: +200$ °C ($+392$ °F) | $T_a: -40$ °C (-40 °F)
- P5 = $T_p: -40$ °C (-40 °F) | $T_a: -40$ °C (-40 °F)
- P6 = $T_p: -196$ °C (-320 °F) | $T_a: +7$ °C ($+45$ °F)

Housing 316L

316L housing; process temperature -20 to $+150$ °C (-4 to $+302$ °F)

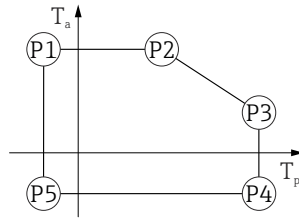

A0032024

▣ 38 316L housing; process temperature -20 to $+150$ °C (-4 to $+302$ °F)

- P1 = T_p : -20 °C (-4 °F) | T_a : $+77$ °C ($+171$ °F)
- P2 = T_p : $+77$ °C ($+171$ °F) | T_a : $+77$ °C ($+171$ °F)
- P3 = T_p : $+150$ °C ($+302$ °F) | T_a : $+43$ °C ($+109$ °F)
- P4 = T_p : $+150$ °C ($+302$ °F) | T_a : -20 °C (-4 °F)
- P5 = T_p : -20 °C (-4 °F) | T_a : -20 °C (-4 °F)

316L housing; process temperature -20 to $+200$ °C (-4 to $+392$ °F)

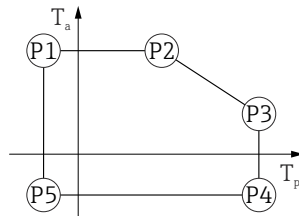

A0032024

▣ 39 316L housing; process temperature -20 to $+200$ °C (-4 to $+392$ °F)

- P1 = T_p : -20 °C (-4 °F) | T_a : $+77$ °C ($+171$ °F)
- P2 = T_p : $+77$ °C ($+171$ °F) | T_a : $+77$ °C ($+171$ °F)
- P3 = T_p : $+200$ °C ($+392$ °F) | T_a : $+38$ °C ($+100$ °F)
- P4 = T_p : $+200$ °C ($+392$ °F) | T_a : -20 °C (-4 °F)
- P5 = T_p : -20 °C (-4 °F) | T_a : -20 °C (-4 °F)

316L housing; process temperature -40 to $+150$ °C (-40 to $+302$ °F)

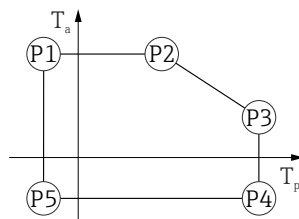

A0032024

▣ 40 316L housing; process temperature range: -40 to $+150$ °C (-40 to $+302$ °F)

- P1 = T_p : -40 °C (-40 °F) | T_a : $+77$ °C ($+171$ °F)
- P2 = T_p : $+77$ °C ($+171$ °F) | T_a : $+77$ °C ($+171$ °F)
- P3 = T_p : $+150$ °C ($+302$ °F) | T_a : $+43$ °C ($+109$ °F)
- P4 = T_p : $+150$ °C ($+302$ °F) | T_a : -40 °C (-40 °F)
- P5 = T_p : -40 °C (-40 °F) | T_a : -40 °C (-40 °F)

316L housing; process temperature -40 to $+200$ °C (-40 to $+392$ °F)

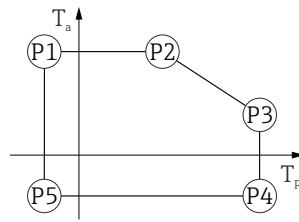

A0032024

▣ 41 316L housing; process temperature -40 to $+200$ °C (-40 to $+392$ °F)

- P1 = $T_p: -40$ °C (-40 °F) | $T_a: +77$ °C ($+171$ °F)
- P2 = $T_p: +77$ °C ($+171$ °F) | $T_a: +77$ °C ($+171$ °F)
- P3 = $T_p: +200$ °C ($+392$ °F) | $T_a: +38$ °C ($+100$ °F)
- P4 = $T_p: +200$ °C ($+392$ °F) | $T_a: -40$ °C (-40 °F)
- P5 = $T_p: -40$ °C (-40 °F) | $T_a: -40$ °C (-40 °F)

316L housing; process temperature -40 to $+280$ °C (-40 to $+536$ °F)

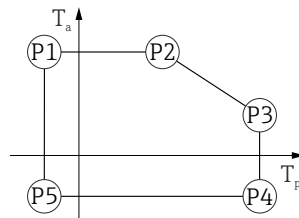

A0032024

▣ 42 316L housing; process temperature -40 to $+280$ °C (-40 to $+536$ °F)

- P1 = $T_p: -40$ °C (-40 °F) | $T_a: +77$ °C ($+171$ °F)
- P2 = $T_p: +77$ °C ($+171$ °F) | $T_a: +77$ °C ($+171$ °F)
- P3 = $T_p: +280$ °C ($+536$ °F) | $T_a: +54$ °C ($+129$ °F)
- P4 = $T_p: +280$ °C ($+536$ °F) | $T_a: -40$ °C (-40 °F)
- P5 = $T_p: -40$ °C (-40 °F) | $T_a: -40$ °C (-40 °F)

316L housing; process temperature -40 to $+450$ °C (-40 to $+842$ °F)

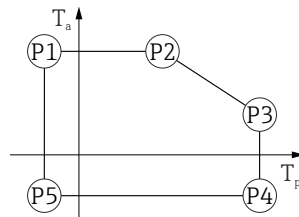

A0032024

▣ 43 316L housing; process temperature -40 to $+450$ °C (-40 to $+842$ °F)

- P1 = $T_p: -40$ °C (-40 °F) | $T_a: +77$ °C ($+171$ °F)
- P2 = $T_p: +77$ °C ($+171$ °F) | $T_a: +77$ °C ($+171$ °F)
- P3 = $T_p: +450$ °C ($+842$ °F) | $T_a: +31$ °C ($+88$ °F)
- P4 = $T_p: +450$ °C ($+842$ °F) | $T_a: -40$ °C (-40 °F)
- P5 = $T_p: -40$ °C (-40 °F) | $T_a: -40$ °C (-40 °F)

316L housing; process temperature -60 to $+150$ °C (-76 to $+302$ °F)

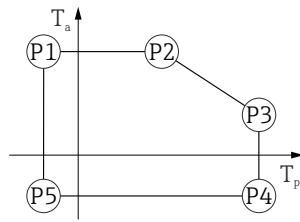

A0032024

▣ 44 316L housing; process temperature -60 to $+150$ °C (-76 to $+302$ °F)

- P1 = T_p : -60 °C (-76 °F) | T_a : $+77$ °C ($+171$ °F)
- P2 = T_p : $+77$ °C ($+171$ °F) | T_a : $+77$ °C ($+171$ °F)
- P3 = T_p : $+150$ °C ($+302$ °F) | T_a : $+43$ °C ($+109$ °F)
- P4 = T_p : $+150$ °C ($+302$ °F) | T_a : -60 °C (-76 °F)
- P5 = T_p : -60 °C (-76 °F) | T_a : -60 °C (-76 °F)

316L housing; process temperature -196 to $+200$ °C (-320 to $+392$ °F)

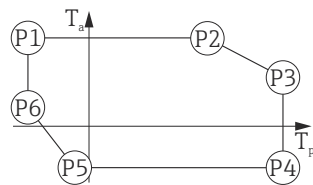

A0050248

▣ 45 316L housing; process temperature -196 to $+200$ °C (-320 to $+392$ °F)

- P1 = T_p : -196 °C (-320 °F) | T_a : $+77$ °C ($+171$ °F)
- P2 = T_p : $+77$ °C ($+171$ °F) | T_a : $+77$ °C ($+171$ °F)
- P3 = T_p : $+200$ °C ($+392$ °F) | T_a : $+38$ °C ($+100$ °F)
- P4 = T_p : $+200$ °C ($+392$ °F) | T_a : -40 °C (-40 °F)
- P5 = T_p : -40 °C (-40 °F) | T_a : -40 °C (-40 °F)
- P6 = T_p : -196 °C (-320 °F) | T_a : $+17$ °C ($+63$ °F)

316L housing, hygiene

316L housing, hygiene; process temperature -20 to $+150$ °C (-4 to $+302$ °F)

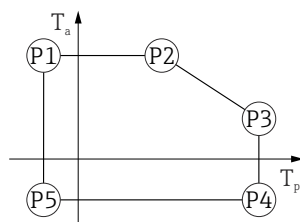

A0032024

▣ 46 316L housing, hygiene; process temperature -20 to $+150$ °C (-4 to $+302$ °F)

- P1 = T_p : -20 °C (-4 °F) | T_a : $+76$ °C ($+169$ °F)
- P2 = T_p : $+76$ °C ($+169$ °F) | T_a : $+76$ °C ($+169$ °F)
- P3 = T_p : $+150$ °C ($+302$ °F) | T_a : $+41$ °C ($+106$ °F)
- P4 = T_p : $+150$ °C ($+302$ °F) | T_a : -20 °C (-4 °F)
- P5 = T_p : -20 °C (-4 °F) | T_a : -20 °C (-4 °F)

316L housing, hygiene; process temperature -20 to +200 °C (-4 to +392 °F)

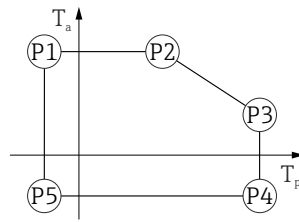

A0032024

47 316L housing, hygiene; process temperature -20 to +200 °C (-4 to +392 °F)

- P1 = T_p : -20 °C (-4 °F) | T_a : +76 °C (+169 °F)
- P2 = T_p : +76 °C (+169 °F) | T_a : +76 °C (+169 °F)
- P3 = T_p : +200 °C (+392 °F) | T_a : +32 °C (+90 °F)
- P4 = T_p : +200 °C (+392 °F) | T_a : -20 °C (-4 °F)
- P5 = T_p : -20 °C (-4 °F) | T_a : -20 °C (-4 °F)

316L housing, hygiene; process temperature -40 to +150 °C (-40 to +302 °F)

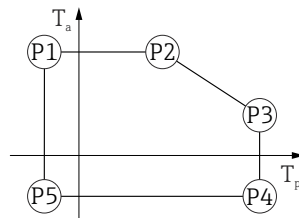

A0032024

48 316L housing, hygiene; process temperature range: -40 to +150 °C (-40 to +302 °F)

- P1 = T_p : -40 °C (-40 °F) | T_a : +76 °C (+169 °F)
- P2 = T_p : +76 °C (+169 °F) | T_a : +76 °C (+169 °F)
- P3 = T_p : +150 °C (+302 °F) | T_a : +41 °C (+106 °F)
- P4 = T_p : +150 °C (+302 °F) | T_a : -40 °C (-40 °F)
- P5 = T_p : -40 °C (-40 °F) | T_a : -40 °C (-40 °F)

316L housing, hygiene; process temperature -40 to +200 °C (-40 to +392 °F)

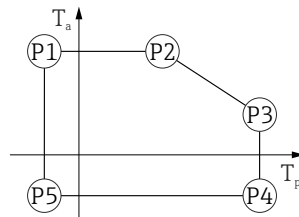

A0032024

49 316L housing, hygiene; process temperature -40 to +200 °C (-40 to +392 °F)

- P1 = T_p : -40 °C (-40 °F) | T_a : +76 °C (+169 °F)
- P2 = T_p : +76 °C (+169 °F) | T_a : +76 °C (+169 °F)
- P3 = T_p : +200 °C (+392 °F) | T_a : +32 °C (+90 °F)
- P4 = T_p : +200 °C (+392 °F) | T_a : -40 °C (-40 °F)
- P5 = T_p : -40 °C (-40 °F) | T_a : -40 °C (-40 °F)

316L housing, hygiene; process temperature -60 to $+150$ °C (-76 to $+302$ °F)

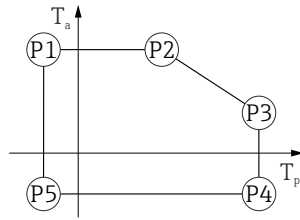

A0050248

50 316L housing, hygiene; process temperature -60 to $+150$ °C (-76 to $+302$ °F)

- P1 = T_p : -60 °C (-76 °F) | T_a : $+76$ °C ($+169$ °F)
- P2 = T_p : $+76$ °C ($+169$ °F) | T_a : $+76$ °C ($+169$ °F)
- P3 = T_p : $+150$ °C ($+302$ °F) | T_a : $+41$ °C ($+106$ °F)
- P4 = T_p : $+150$ °C ($+302$ °F) | T_a : -60 °C (-76 °F)
- P5 = T_p : -60 °C (-76 °F) | T_a : -60 °C (-76 °F)

316L housing, hygiene; process temperature -196 to $+200$ °C (-320 to $+392$ °F)

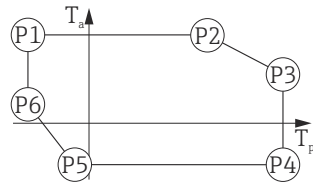

A0050248

51 316L housing, hygiene; process temperature -196 to $+200$ °C (-320 to $+392$ °F)

- P1 = T_p : -196 °C (-320 °F) | T_a : $+76$ °C ($+169$ °F)
- P2 = T_p : $+76$ °C ($+169$ °F) | T_a : $+76$ °C ($+169$ °F)
- P3 = T_p : $+200$ °C ($+392$ °F) | T_a : $+32$ °C ($+90$ °F)
- P4 = T_p : $+200$ °C ($+392$ °F) | T_a : -40 °C (-40 °F)
- P5 = T_p : -40 °C (-40 °F) | T_a : -40 °C (-40 °F)
- P6 = T_p : -196 °C (-320 °F) | T_a : $+32$ °C ($+90$ °F)

Storage temperature

- Without LCD display:
 - Standard: -40 to $+90$ °C (-40 to $+194$ °F)
 - Optionally available: -60 to $+90$ °C (-76 to $+194$ °F) with restricted operating life and performance; below -50 °C (-58 °F): Ex d devices can be permanently damaged
- With LCD display: -40 to $+85$ °C (-40 to $+185$ °F)

Climate class

DIN EN 60068-2-38 (test Z/AD)

Installation height as per IEC61010-1 Ed.3

Generally up to 5 000 m (16 404 ft) above sea level

Degree of protection

Testing in accordance with IEC 60529 and NEMA 250

Housing

IP66/68, NEMA TYPE 4X/6P

IP68 test condition: 1.83 m Under water for 24 hours.

Cable entries

- M20 coupling, plastic, IP66/68 NEMA type 4X/6P
- M20 coupling, nickel-plated brass, IP66/68 NEMA type 4X/6P
- M20 coupling, 316L, IP66/68 NEMA type 4X/6P
- M20 coupling, hygiene, IP66/68/69 NEMA type 4X/6P
- M20 thread, IP66/68 NEMA type 4X/6P

- G ½ thread, IP66/68 NEMA TYPE 4X/6P
If the G ½ thread is selected, the device is provided with an M20 thread as standard and an M20 adapter to G M20 ½ is included, along with the associated documentation
- NPT ½ thread, IP66/68 NEMA TYPE 4X/6P
- M12 plug
 - If the housing is closed and the connecting cable is plugged in: IP66/67 NEMA type 4X
 - If the housing is open or the connecting cable is not plugged in: IP20, NEMA type 1

NOTICE

M12 plug: Loss of IP protection class due to incorrect installation!

- ▶ The degree of protection only applies if the connecting cable used is plugged in and screwed tight.
- ▶ The degree of protection only applies if the connecting cable used is specified according to IP67 NEMA 4X.
- ▶ The protection classes are only fulfilled if the dummy cap is used or the cable is connected.

Vibration resistance	DIN EN 60068-2-64 / IEC 60068-2-64 for 5 to 2 000 Hz: 1.25 (m/s ²)/Hz
Electromagnetic compatibility (EMC)	<ul style="list-style-type: none"> ▪ Electromagnetic compatibility as per EN 61326 series and NAMUR recommendation EMC (NE21) ▪ Maximum measured error during EMC testing: < 0.5 % of the current digital measured value <p>For more details refer to the EU Declaration of Conformity.</p>

Process

Process pressure range



The maximum pressure for the device depends on the lowest-rated component with regard to pressure (components are: process connection, optional mounted parts or accessories).

- ▶ Only operate the device within the specified limits for the components!
- ▶ MWP (Maximum Working Pressure): The MWP is specified on the nameplate. This value refers to a reference temperature of +20 °C (+68 °F) and may be applied to the device for an unlimited time. Note temperature dependence of MWP. For flanges, refer to the following standards for the permitted pressure values at higher temperatures: EN 1092-1 (with regard to their stability/temperature property, the materials 1.4435 and 1.4404 are grouped together under EN 1092-1; the chemical composition of the two materials can be identical), ASME B16.5, JIS B2220 (the latest version of the standard applies in each case). MWP data that deviate from this are provided in the relevant sections of the Technical Information.
- ▶ The Pressure Equipment Directive (2014/68/EU) uses the abbreviation **PS**. This corresponds to the maximum working pressure (MWP) of the device.

The following tables show the dependencies between the seal material, process temperature (T_p) and process pressure range for each process connection that can be selected for the antenna used.

Horn antenna 65 mm (2.6 in)

Process connection standard flange

	Seal	T _p	Process pressure range
	Graphite	-40 to +280 °C (-40 to +536 °F)	-1 to 160 bar (-14.5 to 2 320.6 psi)
	Graphite	-40 to +450 °C (-40 to +842 °F)	-1 to 160 bar (-14.5 to 2 320.6 psi)
	Graphite	-196 to +200 °C (-320 to +392 °F)	-1 to 160 bar (-14.5 to 2 320.6 psi)



The pressure range may be further restricted in the event of a CRN approval.

Drip-off antenna 50 mm (2 in)

Process connection flange

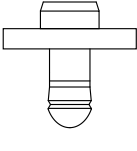
	Seal	T _p	Process pressure range
 <p>A0047953</p>	FKM Viton GLT	-40 to +150 °C (-40 to +302 °F)	-1 to 16 bar (-14.5 to 232 psi)
	FKM Viton GLT	-40 to +200 °C (-40 to +392 °F)	-1 to 16 bar (-14.5 to 232 psi)
	EPDM	-40 to +150 °C (-40 to +302 °F)	-1 to 16 bar (-14.5 to 232 psi)
	HNBR	-20 to +150 °C (-4 to +302 °F)	-1 to 16 bar (-14.5 to 232 psi)
	FFKM Kalrez	-20 to +150 °C (-4 to +302 °F)	-1 to 16 bar (-14.5 to 232 psi)
	FFKM Kalrez	-20 to +200 °C (-4 to +392 °F)	-1 to 16 bar (-14.5 to 232 psi)

i The pressure range may be further restricted in the event of a CRN approval.

Antenna, cladded flush mount, PTFE, 50 mm (2 in)

Process connection flange ASME , EN1092-1, JIS B2220

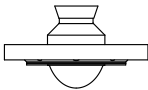
	Seal	T _p	Process pressure range
 <p>A0047824</p>	PTFE cladded	-40 to +150 °C (-40 to +302 °F)	-1 to 25 bar (-14.5 to 362.6 psi)
	PTFE cladded	-40 to +200 °C (-40 to +392 °F)	-1 to 25 bar (-14.5 to 362.6 psi)
	PTFE cladded	-60 to +150 °C (-76 to +302 °F)	-1 to 25 bar (-14.5 to 362.6 psi)
	PTFE cladded	-196 to +200 °C (-320 to +392 °F)	-1 to 25 bar (-14.5 to 362.6 psi)
	PTFE cladded	Steam application -20 to +150 °C (-4 to +302 °F)	-1 to 25 bar (-14.5 to 362.6 psi)
	PTFE cladded	Steam application -20 to +200 °C (-4 to +392 °F)	-1 to 25 bar (-14.5 to 362.6 psi)

i The pressure range may be further restricted in the event of a CRN approval.

Antenna, PTFE cladded, flush mount, 80 mm (3 in)

Process connection flange ASME , EN1092-1, JIS B2220

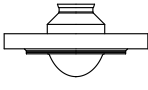
	Seal	T _p	Process pressure range ¹⁾
 <p>A0047835</p>	PTFE cladded	-40 to +150 °C (-40 to +302 °F)	-1 to 25 bar (-14.5 to 362.6 psi)
	PTFE cladded	-40 to +200 °C (-40 to +392 °F)	-1 to 25 bar (-14.5 to 362.6 psi)
	PTFE cladded	-60 to +150 °C (-76 to +302 °F)	-1 to 25 bar (-14.5 to 362.6 psi)
	PTFE cladded	-196 to +200 °C (-320 to +392 °F)	-1 to 25 bar (-14.5 to 362.6 psi)
	PTFE cladded	Steam application -20 to +150 °C (-4 to +302 °F)	-1 to 25 bar (-14.5 to 362.6 psi)
	PTFE cladded	Steam application -20 to +200 °C (-4 to +392 °F)	-1 to 25 bar (-14.5 to 362.6 psi)

1) The process pressure range is restricted to 0 to 25 bar (0 to 362.6 psi) at a process temperature > +100 °C (+212 °F) and flange ≥ DN150/6"/150A.

i The pressure range may be further restricted in the event of a CRN approval.

Dielectric constant

For liquids

ε_r ≥ 1.2

Contact Endress+Hauser for applications with lower dielectric constants than indicated.

Mechanical construction

Dimensions



The dimensions of the individual components must be added together for the total dimensions.

Single compartment housing, plastic

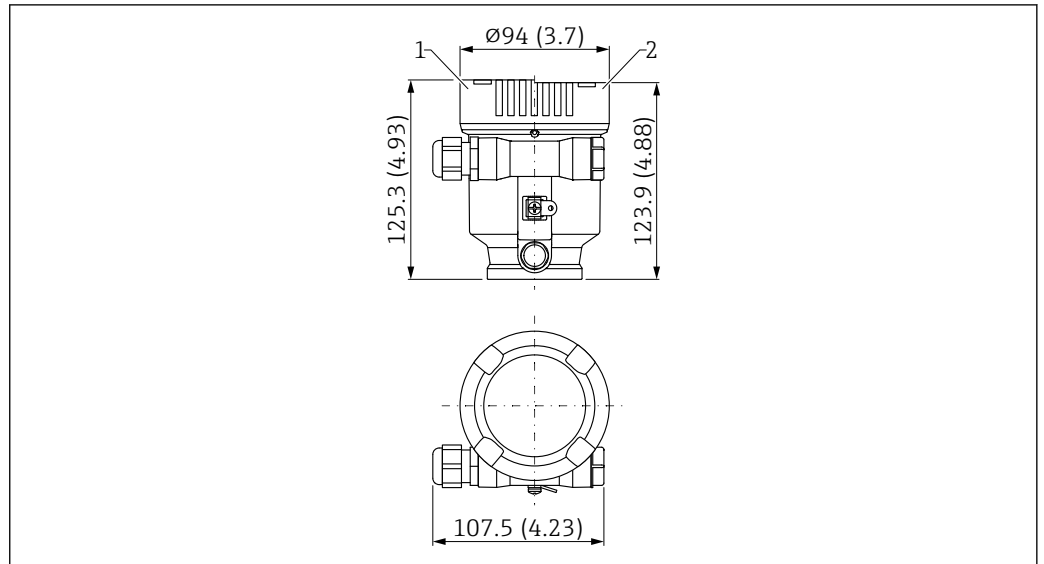

A0048768

52 Dimensions; single compartment housing, plastic; incl. M20 coupling and plug, plastic. Unit of measurement mm (in)

- 1 Height with cover comprising plastic sight glass
- 2 Height with cover without sight glass

Single compartment housing, aluminum, coated

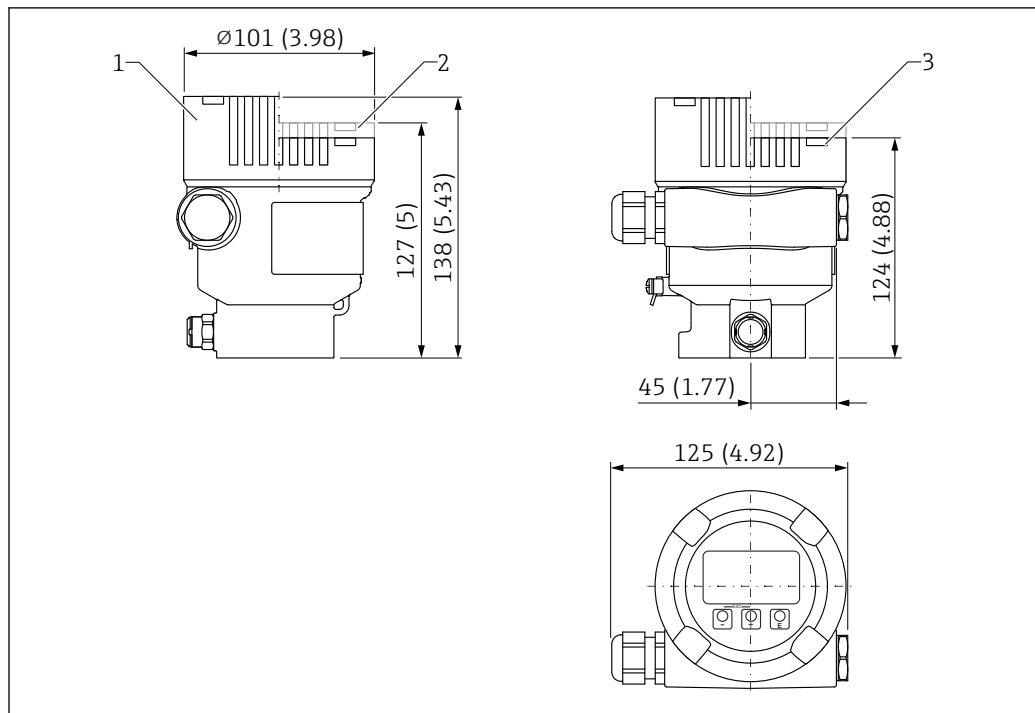

A0038380

53 Dimensions; single compartment housing, aluminum, coated; incl. M20 coupling and plug, plastic. Unit of measurement mm (in)

- 1 Height with cover comprising glass sight glass (devices for Ex d/XP, dust Ex)
- 2 Height with cover comprising plastic sight glass
- 3 Cover without sight glass

Single compartment housing, 316L, hygiene

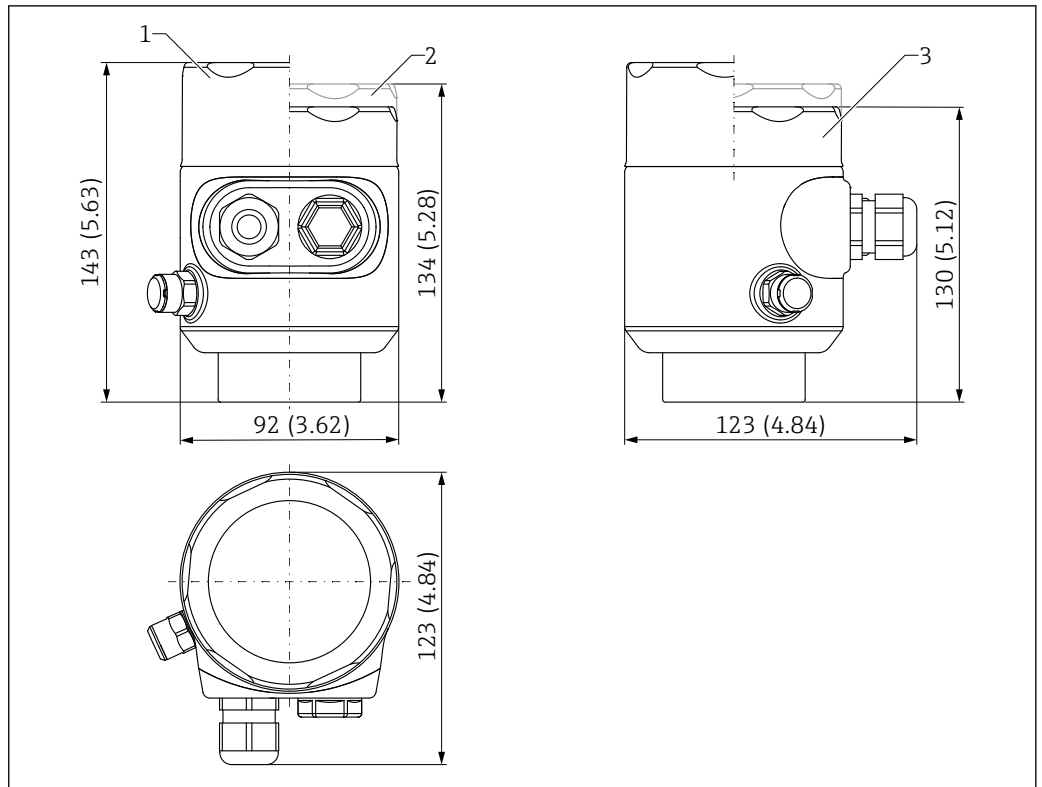

54 Dimensions; single compartment housing, 316 L, hygiene; incl. M20 coupling and plug, plastic. Unit of measurement mm (in)

- 1 Height with cover comprising glass sight glass (dust ignition-proof)
- 2 Height with cover comprising plastic sight glass
- 3 Cover without sight glass

Dual compartment housing, aluminum, coated

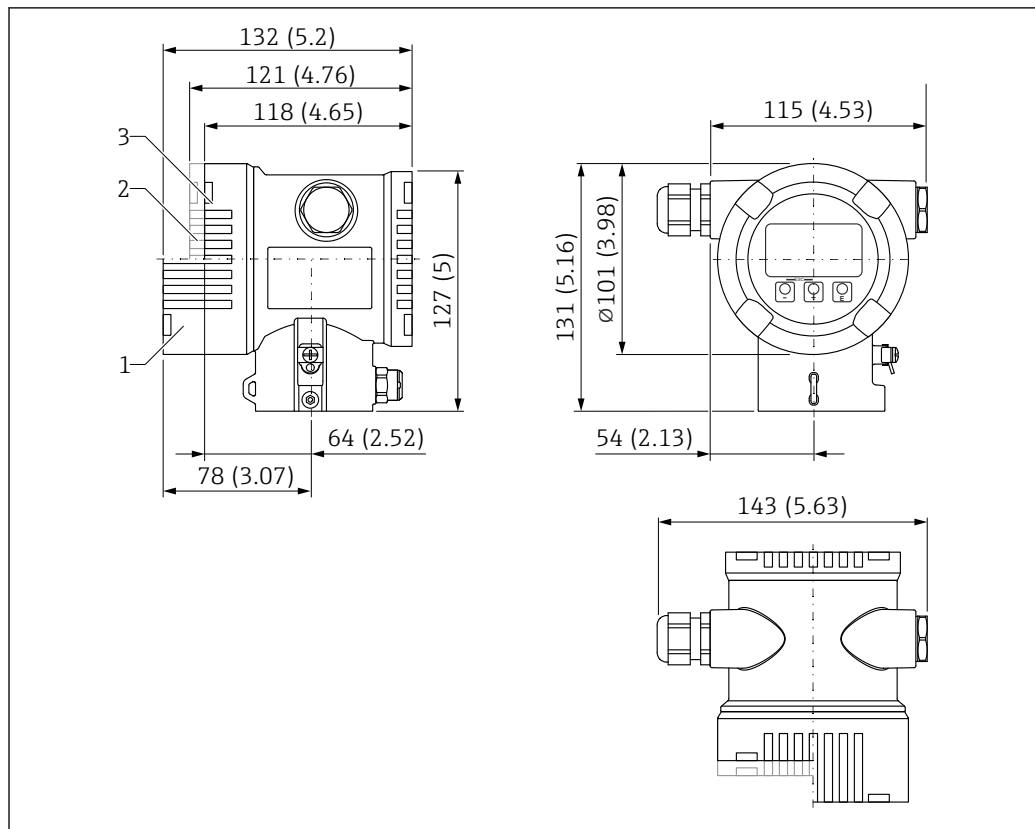

A0038377

55 Dimensions; dual compartment housing, aluminum, coated; incl. M20 coupling and plug, plastic. Unit of measurement mm (in)

- 1 Height with cover comprising glass sight glass (devices for Ex d/XP, dust Ex)
- 2 Height with cover comprising plastic sight glass
- 3 Cover without sight glass

Dual compartment housing, L-shaped, aluminum, coated

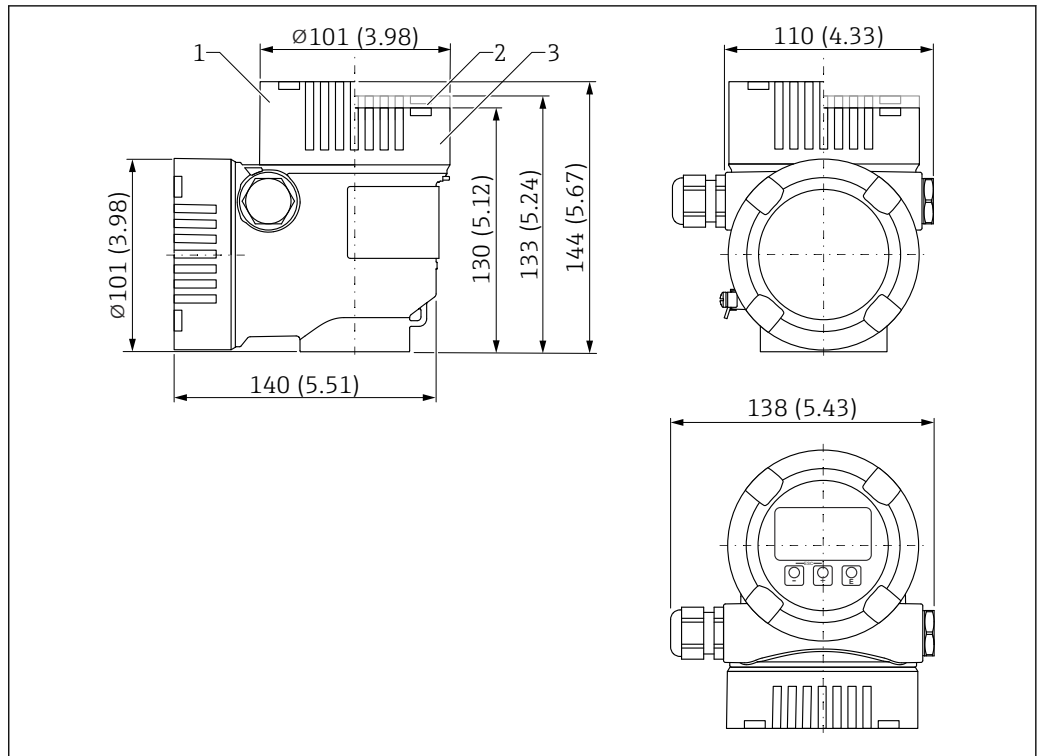

56 Dimensions; dual compartment housing L-shaped, aluminum, coated; incl. M20 coupling and plug, plastic. Unit of measurement mm (in)

- 1 Height with cover comprising glass sight glass (devices for Ex d/XP, dust Ex)
- 2 Height with cover comprising plastic sight glass
- 3 Cover without sight glass

Dual compartment housing, L-shaped, 316L

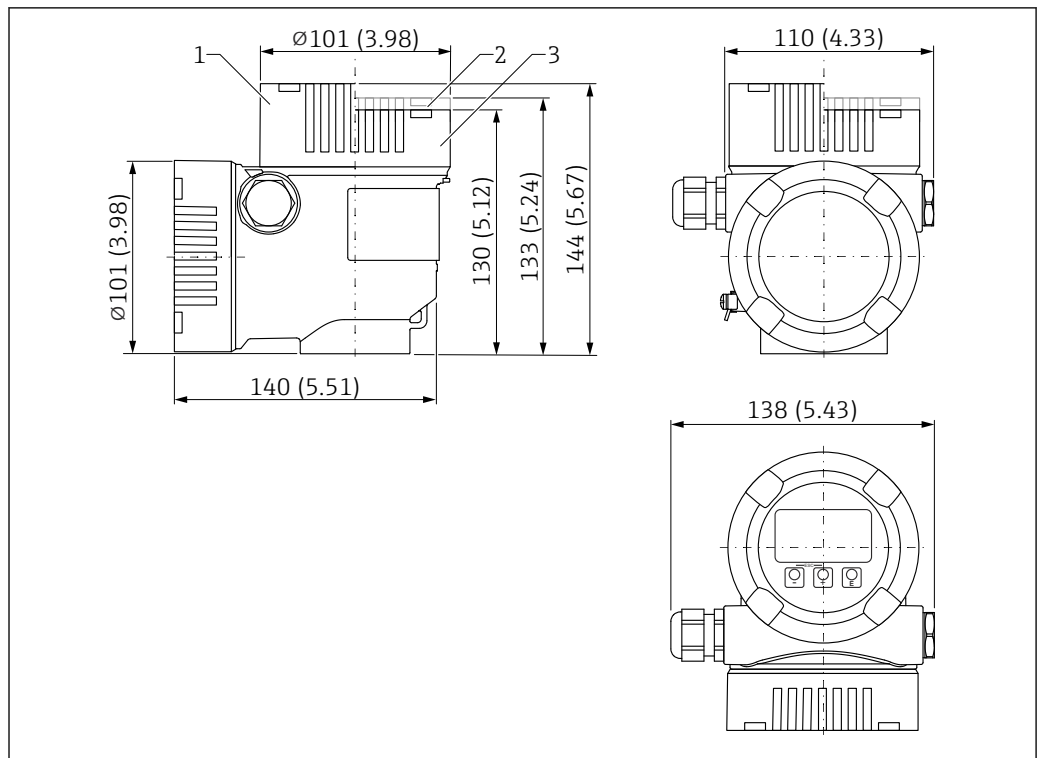

A0038381

57 Dimensions; dual compartment housing L-shaped, 316L; incl. M20 coupling and plug, plastic. Unit of measurement mm (in)

- 1 Height with cover comprising glass sight glass (devices for Ex d/XP, dust Ex)
- 2 Height with cover comprising plastic sight glass
- 3 Cover without sight glass

DN65 horn antenna - flange process connection

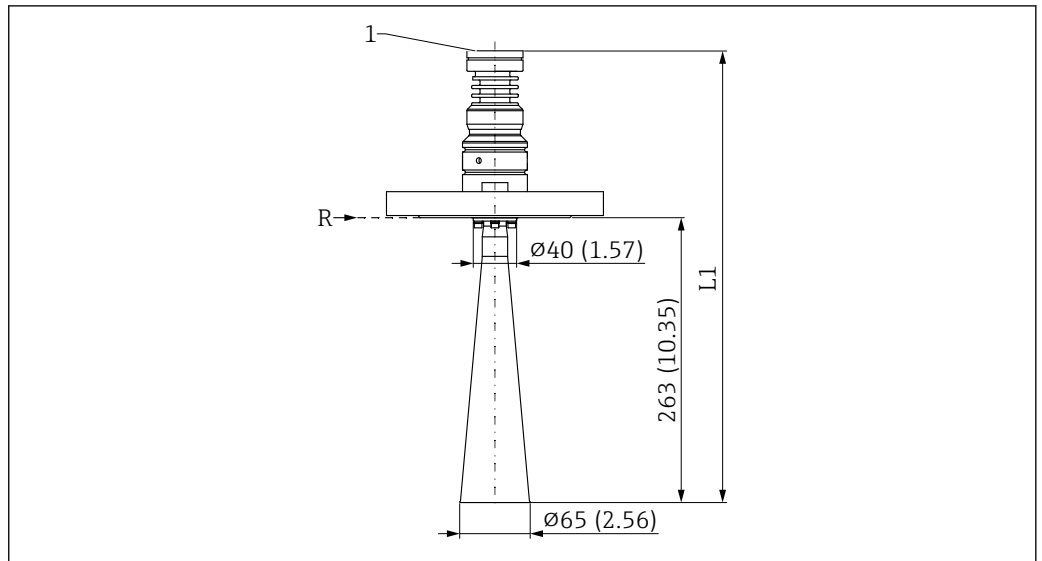

A0046495

58 Dimensions of DN65 horn antenna - flange process connection. Unit of measurement mm (in)

R Reference point of the measurement

1 Lower edge of housing

L1 466 mm (18.35 in); version with Ex d or XP approval +5 mm (+0.20 in)



The flange dimensions depend on the selected standard and sealing surface (order options). Dimensions that deviate from the standard are indicated.

Drip-off antenna - flange process connection

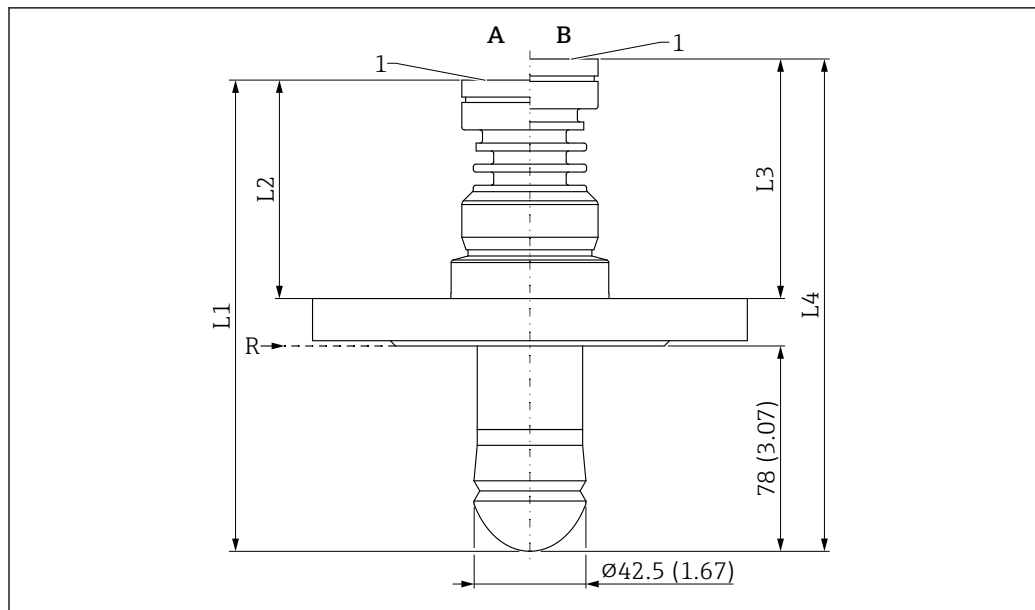

A0046498

59 Dimensions of flange process connection. Unit of measurement mm (in)

A Process temperature version ≤ 150 °C (302 °F)

B Process temperature version ≤ 200 °C (392 °F)

R Reference point of measurement

1 Bottom edge of housing

L1 175 mm (6.89 in); version with Ex d or XP approval +5 mm (+0.20 in)

L2 Variable dimension due to flange thickness (standard flange)

L3 Variable dimension due to flange thickness (standard flange)

L4 187 mm (7.36 in); version with Ex d or XP approval +5 mm (+0.20 in)



The flange dimensions depend on the selected standard and sealing surface (order options).

Dimensions that deviate from the standard are indicated.

Antenna, cladded flush mount, PTFE, 50 mm (2 in), with flange

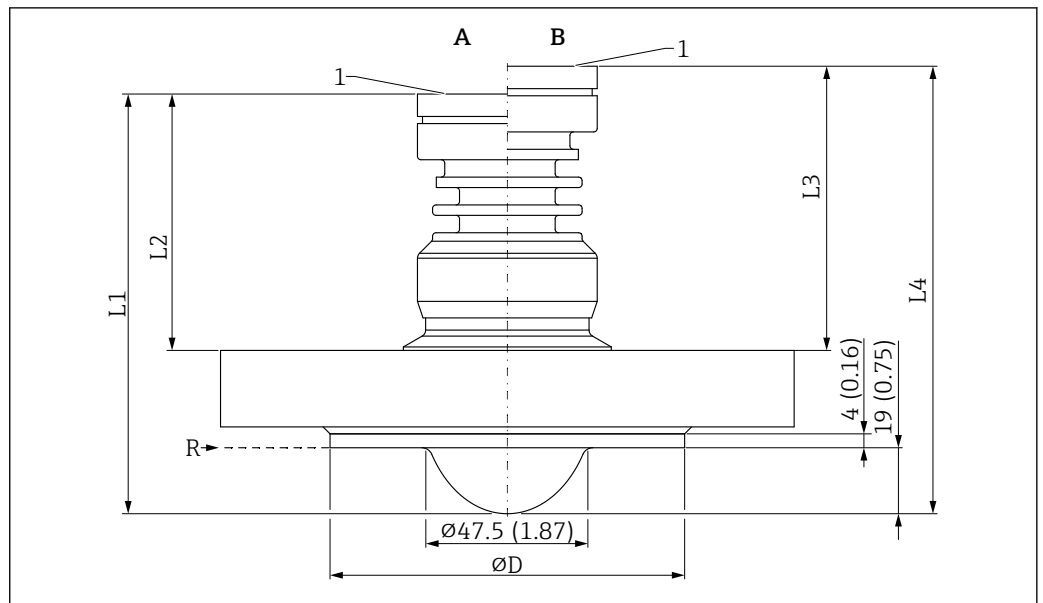

60 Dimensions of antenna, cladded flush mount, PTFE, 50 mm (2 in), with flange. Unit of measurement mm (in)

A Process temperature version ≤ 150 °C (302 °F)

B Process temperature version ≤ 200 °C (392 °F)

R Reference point of measurement

1 Bottom edge of housing

ØD Cladding = sealing surface according to flange standard ASME B16.5 / EN1092-1 / JIS B2220

L1 117 mm (4.61 in); version with Ex d or XP approval +5 mm (+0.20 in)

L2 Variable dimension due to flange thickness (standard flange)

L3 Variable dimension due to flange thickness (standard flange)

L4 129 mm (5.08 in); version with Ex d or XP approval +5 mm (+0.20 in)

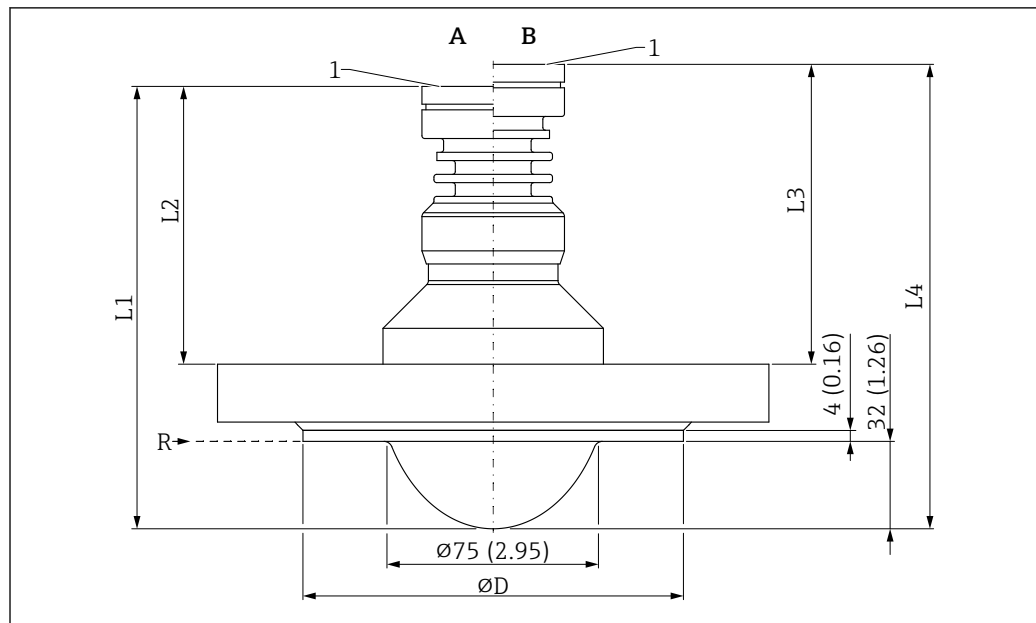

The flange dimensions depend on the selected standard and sealing surface (order options). Dimensions that deviate from the standard are indicated.

Antenna, cladded flush mount, PTFE, 80 mm (3 in), with flange

61 Dimensions of antenna, cladded flush mount, PTFE, 80 mm (3 in), with flange. Unit of measurement mm (in)

A Process temperature version $\leq 150\text{ °C}$ (302 °F)

B Process temperature version $\leq 200\text{ °C}$ (392 °F)

R Reference point of measurement

1 Bottom edge of housing

ØD Cladding = sealing surface according to flange standard ASME B16.5 / EN1092-1 / JIS B2220

L1 157 mm (6.18 in); version with Ex d or XP approval +5 mm (+0.20 in)

L2 Variable dimension due to flange thickness (standard flange)

L3 Variable dimension due to flange thickness (standard flange)

L4 169 mm (6.65 in); version with Ex d or XP approval +5 mm (+0.20 in)



The flange dimensions depend on the selected standard and sealing surface (order options). Dimensions that deviate from the standard are indicated.

Weight

The weights of the individual components must be added together for the total weight.

Housing

Weight including electronics and display.

Single compartment housing

- Plastic: 0.5 kg (1.10 lb)
- Aluminum: 1.2 kg (2.65 lb)
- 316L hygiene: 1.2 kg (2.65 lb)

Dual compartment housing

Aluminum: 1.4 kg (3.09 lb)

Dual compartment housing, L-shaped

- Aluminum: 1.7 kg (3.75 lb)
- Stainless steel: 4.5 kg (9.9 lb)

Antenna and process connection adapter

The flange weight (316/316L) depends on the selected standard and sealing surface. Details -> TI00426F or in the relevant standard



The heaviest version is indicated for the antenna weights

DN65 horn antenna

2.80 kg (6.17 lb) + flange weight

Drip-off antenna 50 mm (2 in)

1.70 kg (3.75 lb) + flange weight

Antenna, cladded flush mount, PTFE, 50 mm (2 in)

1.50 kg (3.31 lb) + flange weight

Antenna, cladded flush mount, PTFE, 80 mm (3 in)

2.9 kg (6.39 lb) + flange weight

Materials

Materials not in contact with process

Single compartment housing, plastic

- Housing: PBT/PC
- Dummy cover: PBT/PC
- Cover with sight glass: PBT/PC and PC
- Cover seal: EPDM
- Potential equalization: 316L
- Seal under potential equalization: EPDM
- Plug: PBT-GF30-FR
- Seal on plug: EPDM
- Nameplate: plastic foil
- TAG plate: plastic foil, metal or provided by the customer

 The cable entry (material: Stainless steel, nickel-plated brass, plastic) can be ordered via the "Electrical connection" product structure.

Single compartment housing, aluminum, coated

- Housing: aluminum EN AC 43400
- Housing coating, cover: polyester
- EN AC-43400 aluminum cover with Lexan 943A PC sight glass
EN AC-443400 aluminum cover with borosilicate sight glass; dust-Ex for Ex d/XP
- Dummy cover: aluminum EN AC 43400
- Cover sealing materials: HNBR
- Cover sealing materials: FVMQ (in low temperature version only)
- Plug: PBT-GF30-FR or aluminum
- Plug sealing material: EPDM
- Nameplate: plastic foil
- TAG plate: plastic foil, stainless steel or provided by the customer

 The cable entry (material: Stainless steel, nickel-plated brass, plastic) can be ordered via the "Electrical connection" product structure.

Single compartment housing, 316L, hygienic

- Housing: stainless steel 316 L (1.4404)
- Dummy cover: stainless steel 316 L (1.4404)
- Cover stainless steel 316 L (1.4404) with PC Lexan 943A sight glass
Cover stainless steel 316 L (1.4404) with borosilicate sight glass; can optionally be ordered as a mounted accessory
For dust ignition-proof applications, the sight glass is always made of borosilicate.
- Cover sealing materials: VMQ
- Plug: PBT-GF30-FR or stainless steel
- Plug sealing material: EPDM
- Nameplate: stainless steel housing labeled directly
- TAG plate: plastic foil, stainless steel or provided by the customer

 The cable entry (material: Stainless steel, nickel-plated brass, plastic) can be ordered via the "Electrical connection" product structure.

Dual compartment housing, aluminum, coated

- Housing: aluminum EN AC 43400
- Housing coating, cover: polyester
- EN AC-43400 aluminum cover with Lexan 943A PC sight glass
EN AC-443400 aluminum cover with borosilicate sight glass; dust-Ex for Ex d/XP
- Dummy cover: aluminum EN AC 43400
- Cover sealing materials: HNBR
- Cover sealing materials: FVMQ (in low temperature version only)

- Plug: PBT-GF30-FR or aluminum
- Plug sealing material: EPDM
- Nameplate: plastic foil
- TAG plate: plastic foil, stainless steel or provided by the customer

 The cable entry (material: Stainless steel, nickel-plated brass, plastic) can be ordered via the "Electrical connection" product structure.

Dual compartment housing; 316L

- Housing: stainless steel AISI 316L (1.4409)
Stainless steel (ASTM A351 : CF3M (cast equivalent to AISI 316L material)/DIN EN 10213 : 1.4409)
- Dummy cover: stainless steel AISI 316L (1.4409)
- Cover: stainless steel AISI 316L (1.4409) with borosilicate sight glass
- Cover sealing materials: HNBR
- Cover sealing materials: FVMQ (in low temperature version only)
- Plug: stainless steel
- Plug sealing material: EPDM
- Nameplate: stainless steel
- TAG plate: plastic foil, stainless steel or provided by the customer

 The cable entry (material: Stainless steel, nickel-plated brass, plastic) can be ordered via the "Electrical connection" product structure.

Dual compartment housing, L-shaped, aluminum, coated

- Housing: aluminum EN AC 43400
- Housing coating, cover: polyester
- EN AC-43400 aluminum cover with Lexan 943A PC sight glass
EN AC-443400 aluminum cover with borosilicate sight glass; dust-Ex for Ex d/XP
- Dummy cover: aluminum EN AC 43400
- Cover sealing materials: HNBR
- Cover sealing materials: FVMQ (in low temperature version only)
- Plug: PBT-GF30-FR or aluminum
- Plug sealing material: EPDM
- Nameplate: plastic foil
- TAG plate: plastic foil, stainless steel or provided by the customer

 The cable entry (material: Stainless steel, nickel-plated brass, plastic) can be ordered via the "Electrical connection" product structure.

Dual compartment housing, L-shaped, 316L

- Housing: stainless steel AISI 316L (1.4409)
Stainless steel (ASTM A351 : CF3M (cast equivalent to AISI 316L material)/DIN EN 10213 : 1.4409)
- Dummy cover: stainless steel AISI 316L (1.4409)
- Cover: stainless steel AISI 316L (1.4409) with borosilicate sight glass
- Cover sealing materials: HNBR
- Cover sealing materials: FVMQ (in low temperature version only)
- Plug: stainless steel
- Plug sealing material: EPDM
- Nameplate: stainless steel housing labeled directly
- TAG plate: plastic foil, stainless steel or provided by the customer

 The cable entry (material: Stainless steel, nickel-plated brass, plastic) can be ordered via the "Electrical connection" product structure.

Cable entry

Coupling M20, plastic

- Material: PA
- Seal on cable gland: EPDM
- Dummy plug: plastic

Coupling M20, nickel-plated brass

- Material: nickel-plated brass
- Seal on cable gland: EPDM
- Dummy plug: plastic

Coupling M20, 316L

- Material: 316L
- Seal on cable gland: EPDM
- Dummy plug: plastic

M20 coupling, 316 L, hygiene

- Material: 316L
- Seal on cable gland: EPDM

M20 thread

The device is supplied with M20 thread as standard.

Transport plug: LD-PE

Thread G ½

The device is supplied as standard with an M20 thread and an enclosed adapter to G ½ including documentation (aluminum housing, 316L housing, hygienic housing) or with a mounted adapter to G ½ (plastic housing).

- Adapter made of PA66-GF or aluminum or 316L (depends on housing version ordered)
- Transport plug: LD-PE

NPT ½ thread

The device is supplied as standard with an NPT ½ thread (aluminum housing, 316L housing) or with a mounted adapter to NPT ½ (plastic housing, hygienic housing).

- Adapter made of PA66-GF or 316L (depends on housing version ordered)
- Transport plug: LD-PE

M20 coupling, blue plastic

- Material: PA, blue
- Seal on cable gland: EPDM
- Dummy plug: plastic

M12 plug

- Material: nickel-plated CuZn or 316L (depends on housing version ordered)
- Transport cap: LD-PE

HAN7D plug

Material: aluminum, die-cast zinc, steel

Materials in contact with the medium

DN65 horn antenna

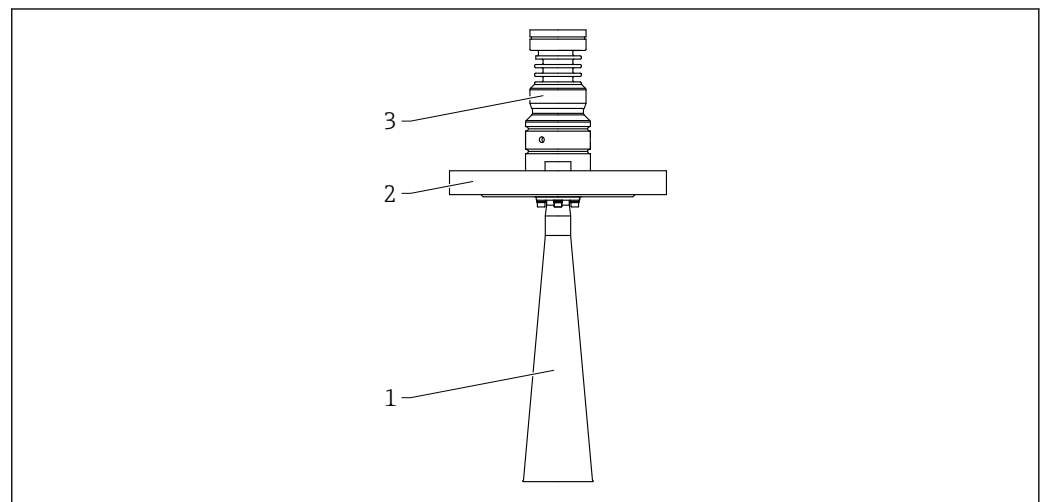

A0046618

62 Material; DN65 horn antenna. Unit of measurement mm (in)

- 1 Horn: 316L (1.4404)
Antenna: Al₂O₃ (ceramic)
Antenna seal: graphite
- 2 Process connection: 316L (1.4404)
- 3 Housing adapter: 316L (1.4404)

Drip-off antenna

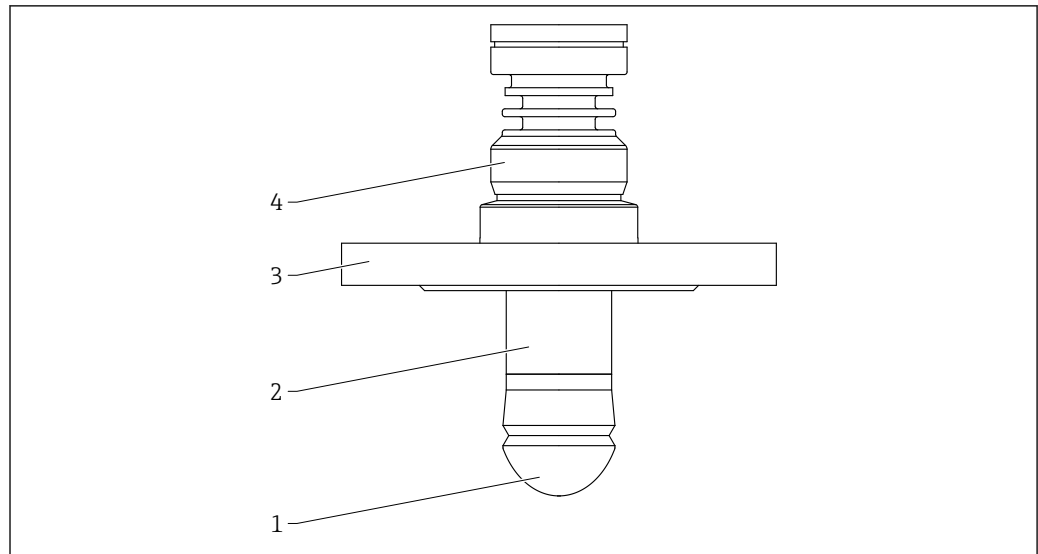

A0046621

63 *Material; Drip-off antenna*

- 1 *Antenna: PTFE, seal material can be selected (order option)*
- 2 *Antenna adapter: 316 L (1.4404)*
- 3 *Process connection: 316L (1.4404)*
- 4 *Housing adapter: 316L (1.4404)*

Antenna, cladded flush mount, PTFE, 50 mm (2 in), with flange

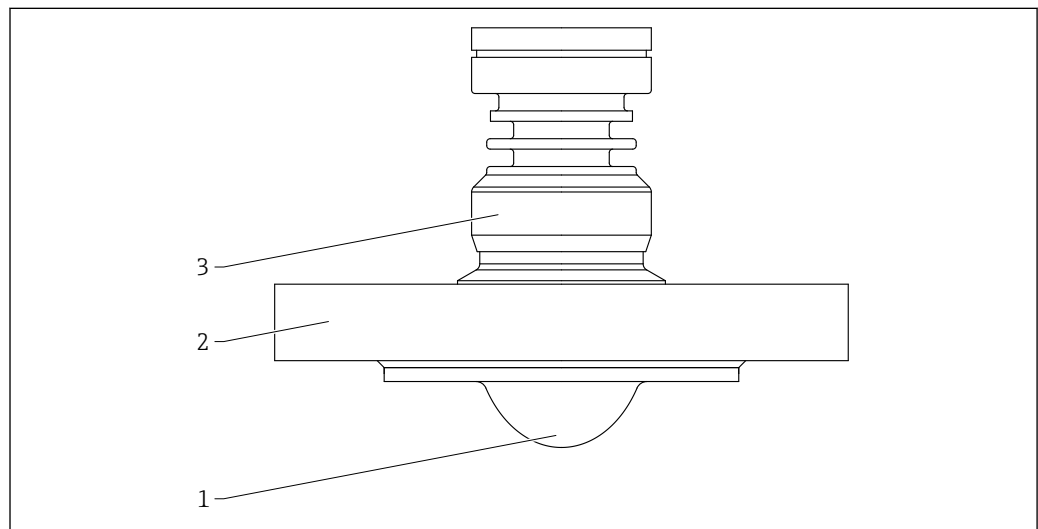

A0046609

64 *Material; antenna, cladded flush mount, PTFE, 50 mm (2 in), with flange*

- 1 *Antenna: PTFE, seal material: PTFE (cladding)*
- 2 *Process connection: 316L (1.4404)*
- 3 *Housing adapter: 316L (1.4404)*

Antenna, cladded flush mount, PTFE, 80 mm (3 in), with flange

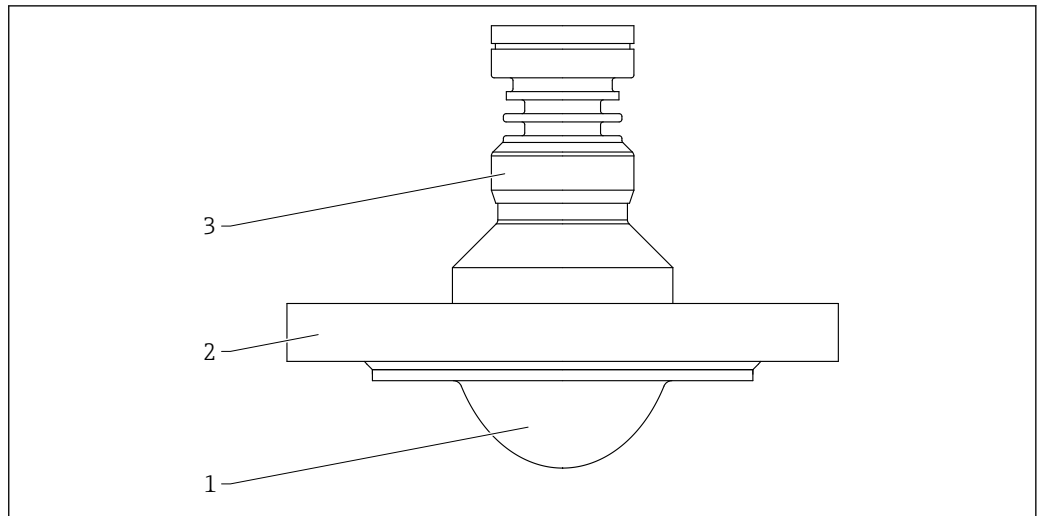

A0046610

▣ 65 *Material; antenna, cladded flush mount, PTFE, 80 mm (3 in), with flange*

- 1 *Antenna: PTFE, seal material: PTFE (cladding)*
- 2 *Process connection: 316L (1.4404)*
- 3 *Housing adapter: 316L (1.4404)*

Operability

Operation concept

Operator-oriented menu structure for user-specific tasks

- User navigation
- Diagnosis
- Application
- System

Quick and safe commissioning

- Interactive wizard with graphical interface for guided commissioning in FieldCare, DeviceCare or DTM and PDM-based tools from third-party users or SmartBlue
- Menu guidance with brief descriptions of the individual parameter functions
- Standardized operation at the device and in the operating tools

Integrated HistoROM data memory

- Adoption of data configuration when electronics modules are replaced
- Up to 100 event messages recorded in the device
- A reference signal curve is saved during commissioning for later use as a reference during operation

Efficient diagnostics increase measurement reliability

- Remedial measures are integrated in plain text
- Diverse simulation options

Bluetooth module (optionally integrated in local display)

- Easy and fast setup via SmartBlue app or PC with DeviceCare from version 1.07.00 or FieldXpert SMT70
- No additional tools or adapters needed
- Encrypted single point-to-point data transmission (tested by Fraunhofer Institute) and password-protected communication via *Bluetooth*® wireless technology

Languages

The operating language of the local display (optional) can be selected via the Product Configurator. The local display is delivered with English from the factory if a different language was not selected. The operating language can be changed subsequently via the **Language** parameter.

Local operation

Local operation with 3 keys (⊕, ⊖, E) on the display.

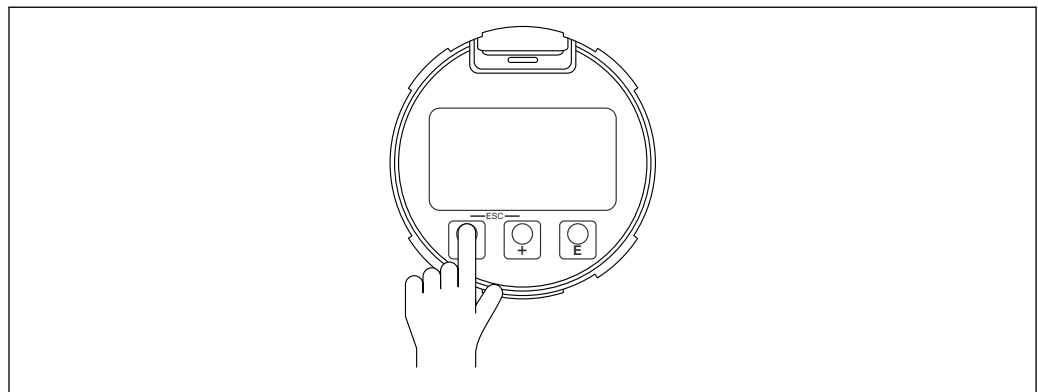

A0046640



The operating elements are also accessible in the various hazardous areas.

Local display

Device display (optional)

Functions

- Display measured values, also fault and notice messages
- Background lighting, which switches from green to red in the event of an error
- The device display can be removed for easier operation



The device displays are available with the additional option of Bluetooth® wireless technology.

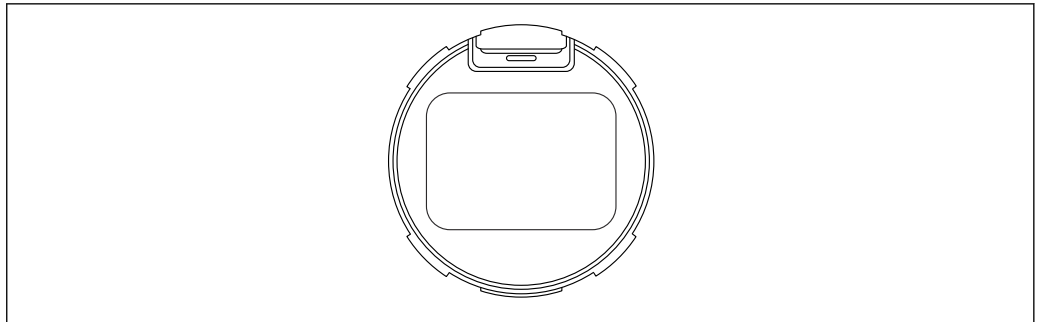

A0043059

66 Segment display without keys

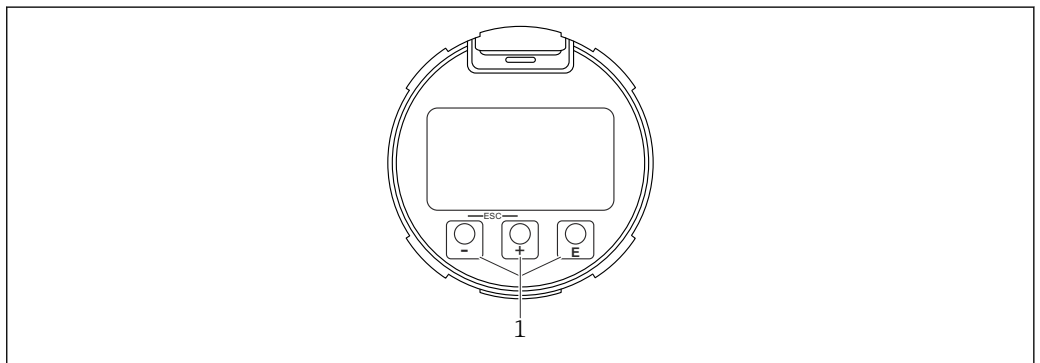

A0039284

67 Graphic display

1 Optical operating keys

Permitted ambient temperature for the display: -20 to $+70$ °C (-4 to $+158$ °F)

The readability of the display may be impaired at temperatures outside the temperature range.

Local operation with 3 keys (+, ESC, E) on the display.

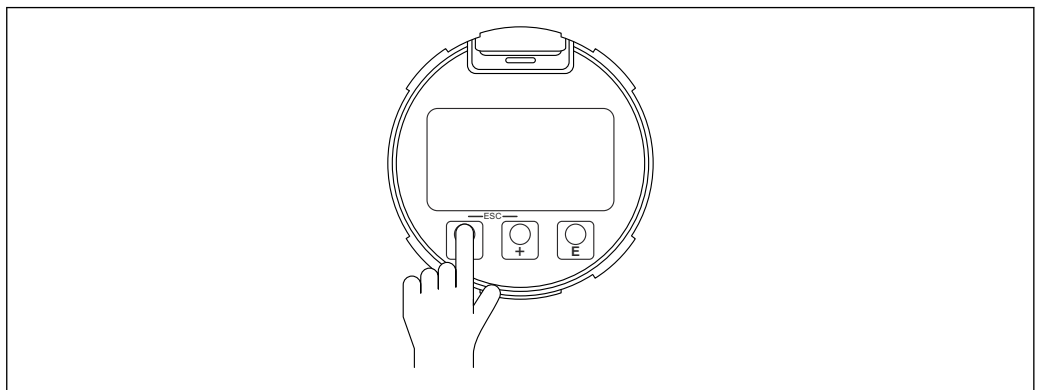

A0046640

 The operating elements are also accessible in the various hazardous areas.

Installation position of device display exchangeable

The installation position of the display can be changed in the case of the dual compartment housing, L-form.

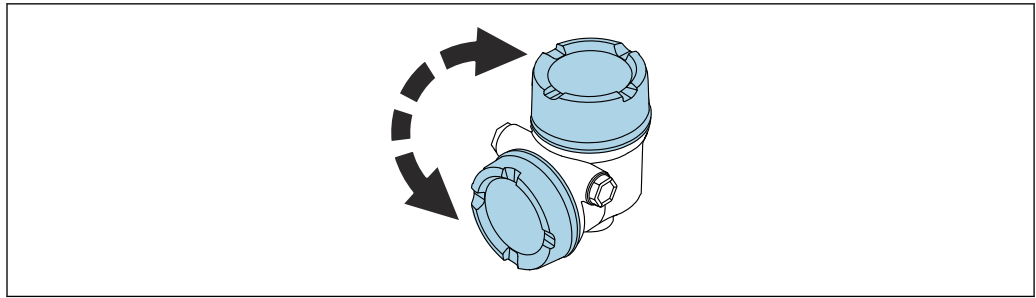

A004B401

Remote operation

Via PROFIBUS PA protocol

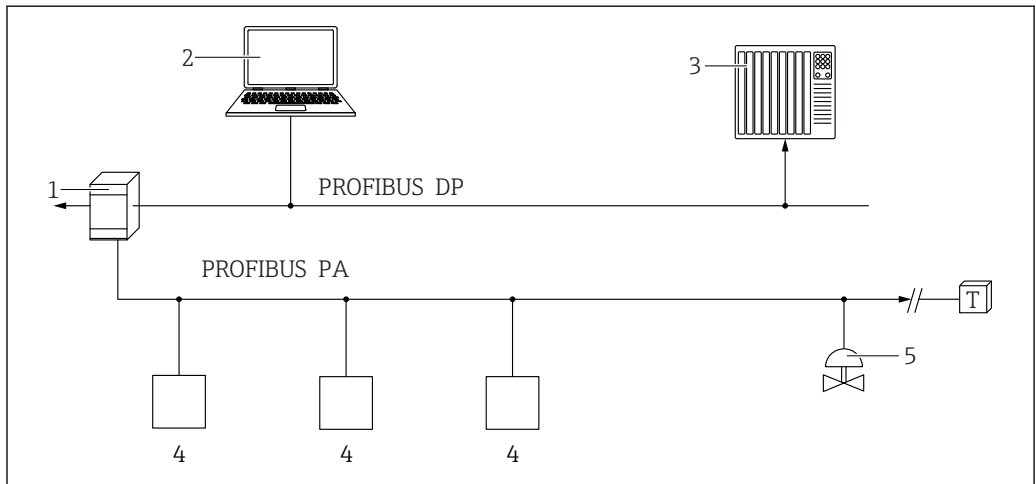

A0050944

- 1 Segment coupler
- 2 Computer with PROFlusb and operating tool (e.g. DeviceCare/FieldCare)
- 3 PLC (programmable logic controller)
- 4 Transmitter
- 5 Additional functions (valves etc.)

Via service interface (CDI)

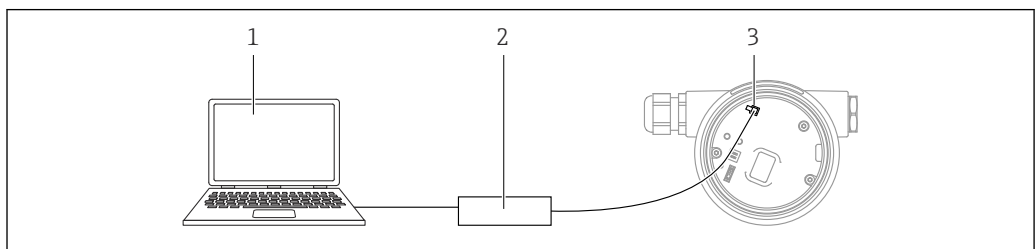

A0039148

- 1 Computer with FieldCare/DeviceCare operating tool
- 2 Commubox
- 3 Service interface (CDI) of the device (= Endress+Hauser Common Data Interface)

Operation via Bluetooth® wireless technology (optional)

Prerequisite

- Measuring device with Bluetooth display
- Smartphone or tablet with SmartBlue app or PC with DeviceCare, version 1.07.00 and higher, or FieldXpert SMT70

The connection has a range of up to 25 m (82 ft). The range can vary depending on environmental conditions such as attachments, walls or ceilings.

System integration

According to EN 50170 Volume 2, IEC 61158-2 (MBP) type 1 PROFIBUS PA Profile Version 3.02

Supported operating tools Smartphone or tablet with Endress+Hauser SmartBlue (app), DeviceCare, version 1.07.00 and higher, FieldCare, DTM, and PDM.

Certificates and approvals

Current certificates and approvals for the product are available at www.endress.com on the relevant product page:

1. Select the product using the filters and search field.
2. Open the product page.
3. Select **Downloads**.

CE mark The measuring system meets the legal requirements of the applicable EU directives. These are listed in the corresponding EU Declaration of Conformity together with the standards applied.
The manufacturer confirms successful testing of the device by affixing to it the CE mark.

RoHS The measuring system meets the substance restrictions of the Directive on the Restriction of the Use of Certain Hazardous Substances 2011/65/EU (RoHS 2) and the Delegated Directive (EU) 2015/863 (RoHS 3).

RCM marking The supplied product or measuring system meets the ACMA (Australian Communications and Media Authority) requirements for network integrity, interoperability, performance characteristics as well as health and safety regulations. Here, especially the regulatory arrangements for electromagnetic compatibility are met. The products bear the RCM marking on the nameplate.



A0029561

Ex approvals Additional safety instructions must be followed for use in hazardous areas. Please refer to the separate "Safety Instructions" (XA) document included in the delivery. Reference to the applicable XA can be found on the nameplate.

Explosion-protected smartphones and tablets

If used in hazardous areas, mobile end devices with an Ex approval must be used.

Pressure equipment with permitted pressure ≤ 200 bar (2 900 psi) Pressure instruments with a process connection that does not have a pressurized housing do not fall within the scope of the Pressure Equipment Directive, irrespective of the maximum allowable pressure.

Reasons:

According to Article 2, point 5 of EU Directive 2014/68/EU, pressure accessories are defined as "devices with an operational function and having pressure-bearing housings".

If a pressure instrument does not have a pressure-bearing housing (no identifiable pressure chamber of its own), there is no pressure accessory present within the meaning of the Directive.

Radio approval Displays with Bluetooth LE have radio licenses according to CE and FCC. The relevant certification information and labels are provided on display.

EN 302729 radio standard The devices comply with the LPR (Level Probing Radar) radio standard EN 302729.
The devices are approved for unrestricted use inside and outside closed containers in countries of the EU and the EFTA. As a prerequisite, the countries must have already implemented this standard.
The standard is already implemented in the following countries:

Belgium, Bulgaria, Germany, Denmark, Estonia, France, Greece, UK, Ireland, Iceland, Italy, Liechtenstein, Lithuania, Latvia, Malta, The Netherlands, Norway, Austria, Poland, Portugal, Romania, Sweden, Switzerland, Slovakia, Spain, Czech Republic and Cyprus.

Implementation is still underway in all of the countries not listed.

Please note the following for operation of the devices outside of closed vessels:

- Installation must be carried out by properly trained, expert staff
- The device antenna must be installed in a fixed location pointing vertically downwards
- The mounting site must be located at a distance of 4 km (2.49 mi) from the astronomy stations listed below or otherwise approval must be provided by the relevant authority. If a device is installed within a radius of 4 to 40 km (2.49 to 24.86 mi) around one of the listed stations, it must not be installed at a height of more than 15 m (49 ft) above the ground

Astronomy stations

Country	Name of the station	Latitude	Longitude
Germany	Effelsberg	50° 31' 32" North	06° 53' 00" East
Finland	Metsähovi	60° 13' 04" North	24° 23' 37" East
	Tuorla	60° 24' 56" North	24° 26' 31" East
France	Plateau de Bure	44° 38' 01" North	05° 54' 26" East
	Floirac	44° 50' 10" North	00° 31' 37" West
Great Britain	Cambridge	52° 09' 59" North	00° 02' 20" East
	Damhall	53° 09' 22" North	02° 32' 03" West
	Jodrell Bank	53° 14' 10" North	02° 18' 26" West
	Knockin	52° 47' 24" North	02° 59' 45" West
	Pickmere	53° 17' 18" North	02° 26' 38" West
Italy	Medicina	44° 31' 14" North	11° 38' 49" East
	Noto	36° 52' 34" North	14° 59' 21" East
	Sardinia	39° 29' 50" North	09° 14' 40" East
Poland	Fort Skala Krakow	50° 03' 18" North	19° 49' 36" East
Russia	Dmitrov	56° 26' 00" North	37° 27' 00" East
	Kalyazin	57° 13' 22" North	37° 54' 01" East
	Pushchino	54° 49' 00" North	37° 40' 00" East
	Zelenchukskaya	43° 49' 53" North	41° 35' 32" East
Sweden	Onsala	57° 23' 45" North	11° 55' 35" East
Switzerland	Bleien	47° 20' 26" North	08° 06' 44" East
Spain	Yebes	40° 31' 27" North	03° 05' 22" West
	Robledo	40° 25' 38" North	04° 14' 57" West
Hungary	Penc	47° 47' 22" North	19° 16' 53" East



As a general rule, the requirements outlined in EN 302729 must be observed.

EN 302372 radio standard

The devices comply with the TLPR (Tanks Level Probing Radar) radio standard EN 302372 and are permitted for use in closed vessels. Points a to f in Annex E of EN 302372 must be observed for the installation.

FCC

This device complies with Part 15 of the FCC rules. Operation is subject to the following two conditions: (1) This device may not cause harmful interference, and (2) this device must accept any interference received, including interference that may cause undesired operation.

[Any] changes or modifications not expressly approved by the party responsible for compliance could void the user's authority to operate the equipment.

The devices are compliant with the FCC Code of Federal Regulations, CFR 47, Part 15, Sections 15.205, 15.207, 15.209.

 In addition, the devices are compliant with Section 15.256. For these LPR (Level Probe Radar) applications the devices must be professionally installed in a downward operating position. In addition, the devices are not allowed to be mounted in a zone of 4 km (2.49 mi) around RAS stations and within a radius of 40 km (24.86 mi) around RAS stations the maximum operation height of devices is 15 m (49 ft) above ground.

Industry Canada

Canada CNR-Gen Section 7.1.3

This device complies with Industry Canada licence-exempt RSS standard(s). Operation is subject to the following two conditions: (1) This device may not interfere, and (2) this device must accept any interference, including interference that may cause undesired operation of the device.

Le présent appareil est conforme aux CNR d'Industrie Canada applicables aux appareils radio exempts de licence. L'exploitation est autorisée aux deux conditions suivantes : (1) l'appareil ne doit pas produire de brouillage, et (2) l'utilisateur de l'appareil doit accepter tout brouillage radioélectrique subi, même si le brouillage est susceptible d'en compromettre le fonctionnement.

[Any] changes or modifications not expressly approved by the party responsible for compliance could void the user's authority to operate the equipment.

- The installation of the LPR/TLPR device shall be done by trained installers, in strict compliance with the manufacturer's instructions.
- The use of this device is on a "no-interference, no-protection" basis. That is, the user shall accept operations of high-powered radar in the same frequency band which may interfere with or damage this device. However, devices found to interfere with primary licensing operations will be required to be removed at the user's expense.
- This device shall be installed and operated in a completely enclosed container to prevent RF emissions, which can otherwise interfere with aeronautical navigation.
- The installer/user of this device shall ensure that it is at least 10 km from the Dominion Astrophysical Radio Observatory (DRAO) near Penticton, British Columbia. The coordinates of the DRAO are latitude 49°19'15" N and longitude 119°37'12" W. For devices not meeting this 10 km separation (e.g., those in the Okanagan Valley, British Columbia,) the installer/user must coordinate with, and obtain the written concurrence of, the Director of the DRAO before the equipment can be installed or operated. The Director of the DRAO may be contacted at 250-497-2300 (tel.) or 250-497-2355 (fax). (Alternatively, the Manager, Regulatory Standards Industry Canada, may be contacted.)

External standards and guidelines

- EN 60529
Degrees of protection provided by enclosures (IP code)
- EN 61010-1
Safety requirements for electrical equipment for measurement, control and laboratory use
- IEC/EN 61326
Emission in accordance with Class A requirements A; Electromagnetic compatibility (EMC requirements)
- NAMUR NE 21
Electromagnetic compatibility (EMC) of industrial process and laboratory control equipment
- NAMUR NE 53
Software of field devices and signal-processing devices with digital electronics
- NAMUR NE 107
Status categorization in accordance with NE 107
- NAMUR NE 131
Requirements for field devices for standard applications

Ordering information

Detailed ordering information is available from your nearest sales organization www.addresses.endress.com or in the Product Configurator at www.endress.com:

1. Select the product using the filters and search field.
2. Open the product page.

3. Select Configuration.

i Product Configurator - the tool for individual product configuration

- Up-to-the-minute configuration data
- Depending on the device: direct input of information specific to the measuring point, such as the measuring range or operating language
- Automatic verification of exclusion criteria
- Automatic creation of the order code and its breakdown in PDF or Excel output format
- Ability to order directly in the Endress+Hauser Online Shop

Calibration

Factory calibration certificate

The calibration points are spread evenly over the measuring range (0 to 100 %). The Empty calibration **E** and Full calibration **F** must be specified to define the measuring range. If this information is missing, antenna-dependent default values are used instead.

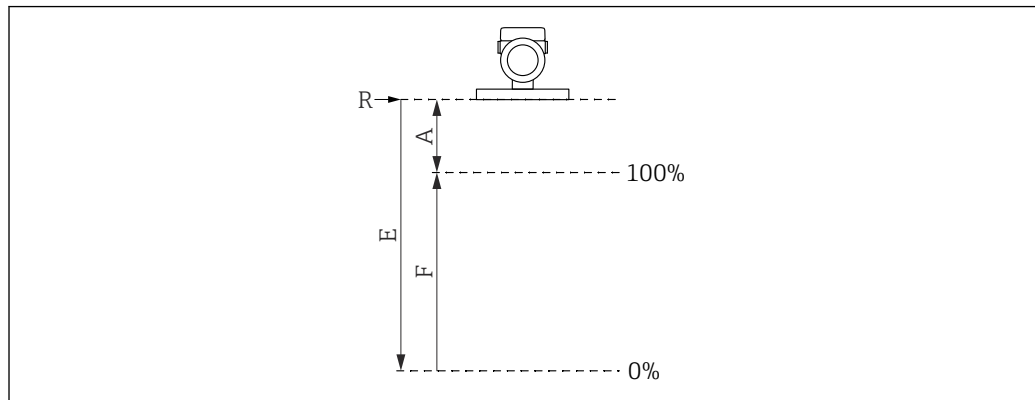

A0032643

- R* Reference point of measurement
A Minimum distance between reference point **R** and 100% mark
E Empty calibration
F Full calibration

Measuring range restrictions

The following restrictions must be considered when selecting **E** and **F**:

- Minimum distance between reference point **R** and 100% mark
 $A \geq 400 \text{ mm (16 in)}$
- Minimum span
 $F \geq 45 \text{ mm (1.77 in)}$
- Maximum value for Empty calibration
 $E \geq 450 \text{ mm (17.72 in)}$ (maximum 50 m (164 ft))

- i** Calibration takes place under reference conditions .
- The selected values for Empty calibration and Full calibration are only used to create the factory calibration certificate. Afterwards, the values are reset to the default values specific for the antenna. If values other than the default values are required, they must be ordered as a customized empty/full calibration.
 Product Configurator → Optional → Service → **Customized empty/full calibration**

Service

Services that can be selected via the product structure in the Product Configurator include.

- Cleaned of oil+grease (wetted)
- PWIS-free (paint-wetting impairment substances)
 - i** The plastic protective cover is excluded from the PWIS cleaning
- ANSI Safety Red coating, coated housing cover
- Set damping
- Bluetooth communication is disabled on delivery
- Customized empty/full calibration
- Product documentation on paper
 A printed (hard copy) version of test reports, declarations and inspection certificates can optionally be ordered via the **Service** feature, **Product documentation on paper** option. The required documents can be selected under the feature **Test, certificate, declaration** and are then included with the device on delivery.

Test, certificate, declaration All test reports, declarations and inspection certificates are provided electronically in the *Device Viewer*:
Enter the serial number from the nameplate (www.endress.com/deviceviewer)

Identification

Measuring point (tag)

The device can be ordered with a tag name.

Location of tag name

In the additional specification, select:

- Stainless steel tag plate
- Paper adhesive label
- Tag provided by the customer
- RFID TAG
- RFID TAG + stainless steel tag plate
- RFID TAG + paper adhesive label
- RFID TAG + TAG provided by the customer
- IEC 61406 stainless steel TAG
- IEC 61406 stainless steel TAG + NFC TAG
- IEC 61406 stainless steel TAG, stainless steel TAG
- IEC 61406 stainless steel TAG + NFC, stainless steel TAG
- IEC 61406 stainless steel TAG, plate provided
- IEC 61406 stainless steel TAG + NFC, plate provided

Definition of tag name

In the additional specification, specify:

3 lines of maximum 18 characters each

The specified tag name appears on the selected plate and/or on the RFID TAG.

Presentation in the SmartBlue app

The first 18 characters of the tag name

The tag name can always be changed specifically for the measuring point via Bluetooth.

Display in electronic nameplate (ENP)

The first 18 characters of the tag name

Display in PROFIBUS PA

The first 18 characters of the tag name are part of the electronic nameplate (ENP) and are also used as TAG_DESC in accordance with the PA Profile 3.02.



For further information, please refer to SD01502F, SD02796P

Available in the Download Area of the Endress+Hauser website (www.endress.com/downloads).

Application packages

Heartbeat Technology

The Heartbeat Verification + Monitoring application package offers diagnostic functionality through continuous self-monitoring, the transmission of additional measured variables to an external Condition Monitoring system and the in-situ verification of devices in the application.

The application package can be ordered together with the device or can be activated subsequently with an activation code. Detailed information on the order code is available via the Endress+Hauser website www.endress.com or from your local Endress+Hauser Sales Center.

Heartbeat Verification

Heartbeat Verification is carried out on request and supplements self-monitoring, which is performed continuously, by carrying out further tests. During verification, the system checks whether the device components comply with the factory specifications. Both the sensor and the electronics modules are included in the tests.

Heartbeat Verification confirms the device function on request within the specified measuring tolerance with a total test coverage TTC (Total Test Coverage) in percent.

Heartbeat Verification meets the requirements for metrological traceability in accordance with ISO 9001 (ISO 9001:2015 Section 7.1.5.2).

The result of the verification is either Passed or Failed. The verification data are saved in the device and optionally archived on a PC with the FieldCare asset management software or in the Netilion Library. Based on this data, a verification report is generated automatically to ensure that traceable documentation of the verification results is available.

Heartbeat Monitoring

Foam detection wizard and **Build-up detection** wizard are available, process windows can be configured. Furthermore, additional monitoring parameters can be displayed and used for predictive maintenance or application optimization.

"Foam detection" wizard

This wizard configures the automatic foam detection.

Foam detection can be linked to an output variable or status information e.g. to control a sprinkler used to dissolve the foam. It is also possible to monitor the foam increase in a so called foam index. The foam index can also be linked to an output variable and can be shown on the display.

Preparation:

The Foam monitoring initialization should only be done without or less foam.

Areas of application

- Measurement in liquids
- Reliable detection of foam on the medium

"Build-up detection" wizard

This wizard configures the build-up detection.

Basic idea:

The build-up detection can, for example, be linked to a compressed-air system to clean the antenna. With the build-up monitoring the maintenance cycles can be optimized.

Preparation:

The build-up monitoring initialization should only be done without or less build-up.

Areas of application

- Measurement in liquids and solids
- Reliable detection of buildup on the antenna

Detailed description



Special documentation SD03093F

Accessories

Weather protection cover: 316L, XW112

The weather protection cover can be ordered together with the device via the "Accessory enclosed" product structure.

It is used to protect against direct sunlight, precipitation and ice.

Weather protection cover 316L is suitable for the dual compartment housing made of aluminum or 316L. The delivery includes the holder for direct mounting on the housing.

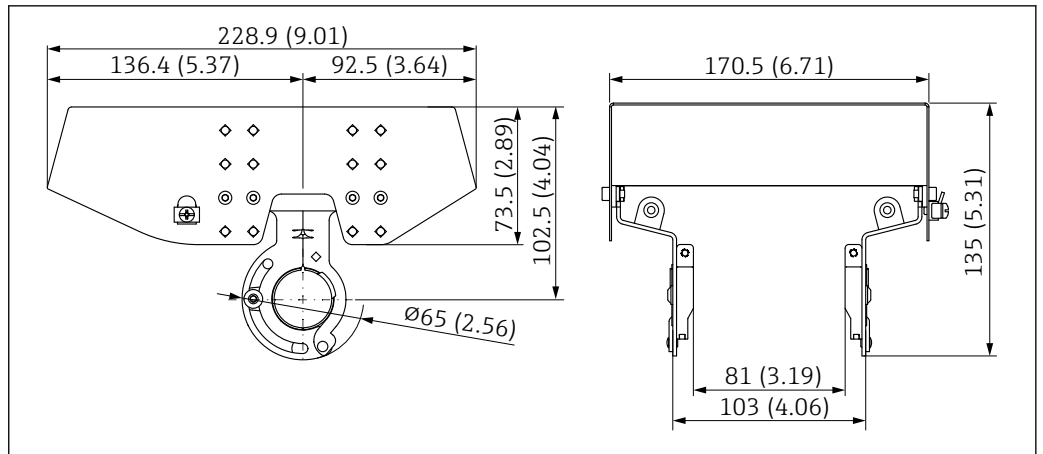

A0039231

68 Dimensions of weather protection cover, 316 L, XW112. Unit of measurement mm (in)

Material

- Weather protection cover: 316L
- Clamping screw: A4
- Holder: 316L

Accessory order code:

71438303

 Special documentation SD02424F

Weather protection cover, plastic, XW111

The weather protection cover can be ordered together with the device via the "Accessory enclosed" product structure.

It is used to protect against direct sunlight, precipitation and ice.

The plastic weather protection cover is suitable for the single compartment housing made of aluminum. The delivery includes the holder for direct mounting on the housing.

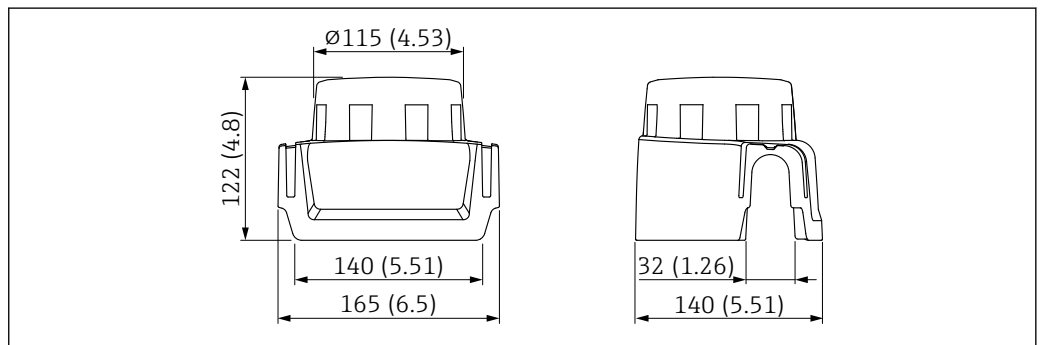

A0038280

69 Dimensions of weather protection cover, plastic, XW111. Unit of measurement mm (in)

Material

Plastic

Accessory order code:

71438291

 Special documentation SD02423F

Remote display FHX50B

The remote display is ordered via the Product Configurator.

If the remote display is to be used, the device version **Prepared for display FHX50B** must be ordered.

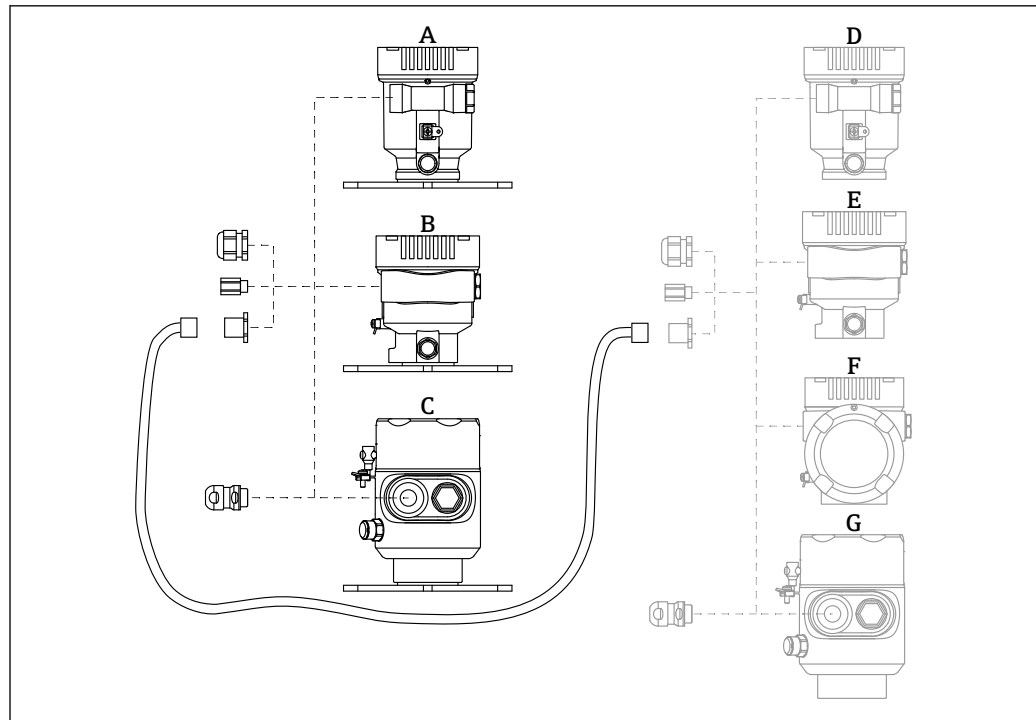

A0046692

- A Single compartment housing, plastic, remote display
 B Single compartment housing, aluminum, remote display
 C Single-compartment housing, 316L hygiene, remote display
 D Device side, single compartment housing, plastic, prepared for FHX50B display
 E Device side, single compartment housing, aluminum, prepared for FHX50B display
 F Device side, dual compartment housing, L-shaped, prepared for FHX50B display
 G Device side, single compartment housing, 316 L hygiene, prepared for FHX50B display

Single compartment housing material, remote display

- Aluminum
- Plastic

Degree of protection:

- IP68 / NEMA 6P
- IP66 / NEMA 4x

Connecting cable:

- Connecting cable (option) up to 30 m (98 ft)
- Standard cable supplied by customer up to 60 m (197 ft)
 Recommendation: EtherLine®-P CAT.5e from LAPP.

Specification of customer-supplied connecting cable

Push-in CAGE CLAMP® connection technology, push actuation

- Conductor cross-section:
 - Solid conductor 0.2 to 0.75 mm² (24 to 18 AWG)
 - Fine-stranded conductor 0.2 to 0.75 mm² (24 to 18 AWG)
 - Fine-stranded conductor; with insulated ferrule 0.25 to 0.34 mm²
 - Fine-stranded conductor; without insulated ferrule 0.25 to 0.34 mm²
- Stripping length 7 to 9 mm (0.28 to 0.35 in)
- Outer diameter: 6 to 10 mm (0.24 to 0.4 in)
- Maximum cable length: 60 m (197 ft)

Ambient temperature:

- -40 to +80 °C (-40 to +176 °F)
- Option: -50 to +80 °C (-58 to +176 °F)



Special documentation SD02991F

Gas-tight feedthrough

Chemically inert glass feedthrough, which prevents gases from entering the electronics housing.

Can optionally be ordered as "Accessory mounted" via the product structure.

Field Xpert SMT70

Universal, high-performance tablet PC for device configuration in Ex Zone 2 and non-Ex areas

 Technical Information TI01342S

DeviceCare SFE100

Configuration tool for HART, PROFIBUS and FOUNDATION Fieldbus field devices

 Technical Information TI01134S

FieldCare SFE500

FDT-based plant asset management tool

It can configure all smart field units in your system and helps you manage them. By using the status information, it is also a simple but effective way of checking their status and condition.

 Technical Information TI00028S

RID14

8-channel field indicator for fieldbus systems

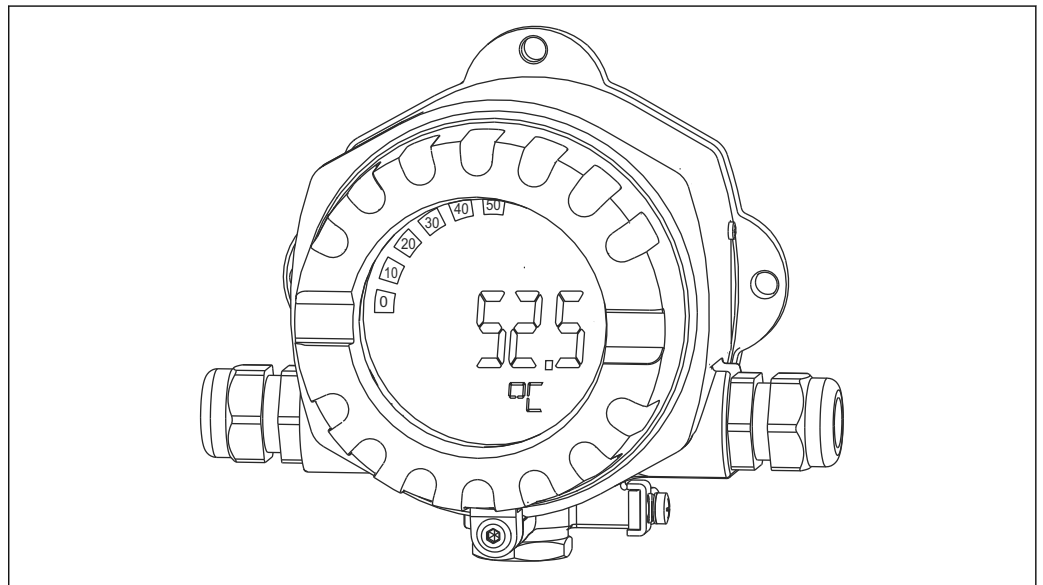

A0011631

Displays 8 process- or calculated values for FOUNDATION Fieldbus™ or PROFIBUS® PA protocol

 Technical Information TI00145R and Operating Instructions BA01267K

RID16

8-channel field indicator for fieldbus systems

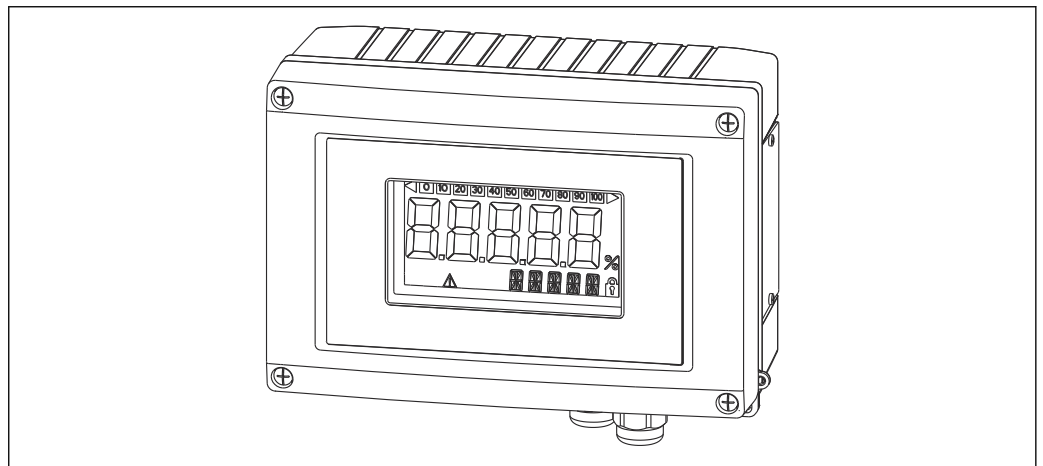

A0011634

Displays 8 process- or calculated values for FOUNDATION Fieldbus™ or PROFIBUS® PA protocol

 Technical Information TI00146R and Operating Instructions BA00284R

Fieldgate SFG500

Smart Ethernet/PROFIBUS gateway

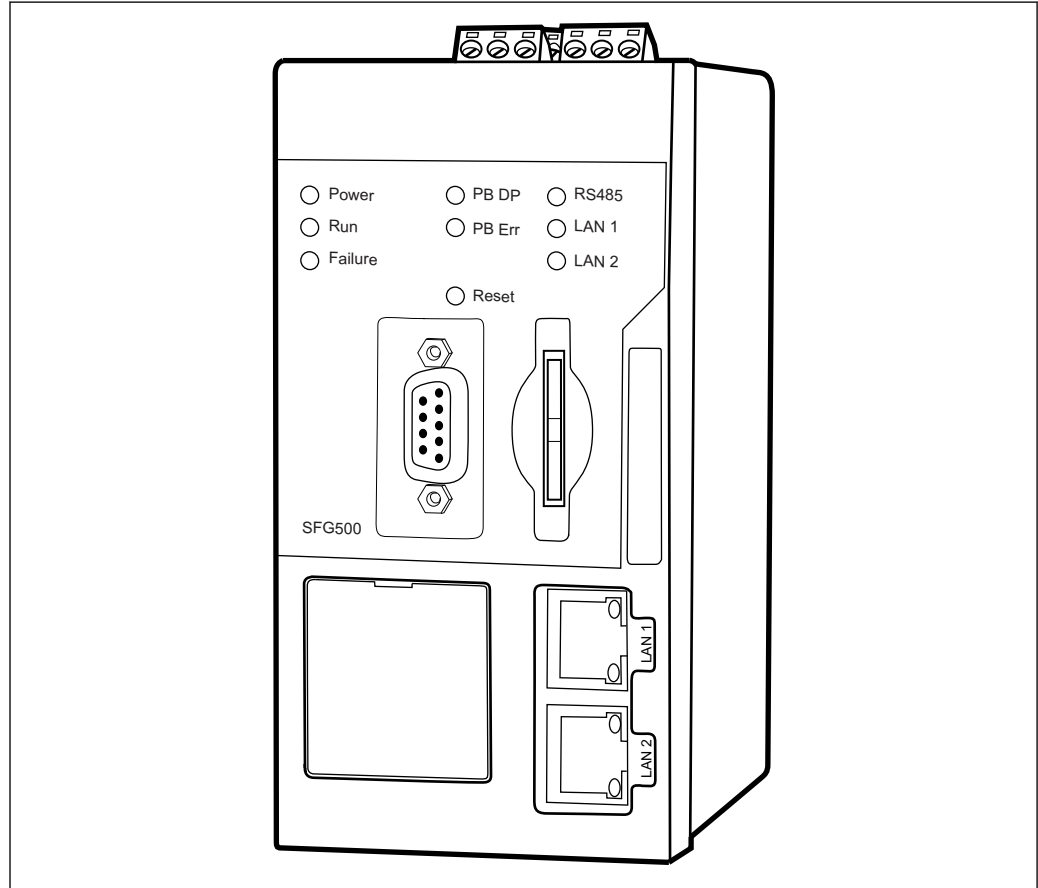

A0028262

Parallel access to PROFIBUS networks, PROFIBUS and HART device status monitoring

Ethernet gateway basic mode with integrated web server and adaptive PROFIBUS master, Class 2 for communication with PROFIBUS devices.

Order number for accessories:
71116672

 Operating Instructions BA01579S

Documentation

The following document types are available in the Downloads area of the Endress+Hauser website (www.endress.com/downloads), depending on the device version:

Document type	Purpose and content of the document
Technical Information (TI)	Planning aid for your device The document contains all the technical data on the device and provides an overview of the accessories and other products that can be ordered for the device.
Brief Operating Instructions (KA)	Guide that takes you quickly to the 1st measured value The Brief Operating Instructions contain all the essential information from incoming acceptance to initial commissioning.

Document type	Purpose and content of the document
Operating Instructions (BA)	<p>Your reference document</p> <p>The Operating Instructions contain all the information that is required in various phases of the life cycle of the device: from product identification, incoming acceptance and storage, to mounting, connection, operation and commissioning through to troubleshooting, maintenance and disposal.</p>
Description of Device Parameters (GP)	<p>Reference for your parameters</p> <p>The document provides a detailed explanation of each individual parameter. The description is aimed at those who work with the device over the entire life cycle and perform specific configurations.</p>
Safety instructions (XA)	<p>Depending on the approval, safety instructions for electrical equipment in hazardous areas are also supplied with the device. These are an integral part of the Operating Instructions.</p> <p> The nameplate indicates which Safety Instructions (XA) apply to the device.</p>
Supplementary device-dependent documentation (SD/FY)	<p>Always comply strictly with the instructions in the relevant supplementary documentation. The supplementary documentation is a constituent part of the device documentation.</p>

Registered trademarks

PROFIBUS®

PROFIBUS and the associated trademarks (The Association Trademark, the Technology Trademarks, the Certification Trademark and the Certified by PI Trademark) are registered trademarks of the PROFIBUS User Organization e.V. (Profibus User Organization), Karlsruhe - Germany

Bluetooth®

The *Bluetooth*® word mark and logos are registered trademarks owned by the Bluetooth SIG, Inc. and any use of such marks by Endress+Hauser is under license. Other trademarks and trade names are those of their respective owners.

Apple®

Apple, the Apple logo, iPhone, and iPod touch are trademarks of Apple Inc., registered in the U.S. and other countries. App Store is a service mark of Apple Inc.

Android®

Android, Google Play and the Google Play logo are trademarks of Google Inc.

KALREZ®, VITON®

Registered trademarks of DuPont Performance Elastomers L.L.C., Wilmington, DE USA



71685538

www.addresses.endress.com
