

Safety Instructions

Raman Rxn5





Raman Rxn5

Table of Contents







1	Warning labels	6
	The warning labels attached to the Raman Rxn5 are shown.....	6
2	Basic safety instructions.....	7
2.1	Requirements for the personnel	7
2.2	Intended use	7
2.3	Electrical safety	7
2.4	Operational safety.....	7
2.5	Product safety.....	8
2.6	Important safeguards.....	8
2.7	Health and safety considerations	8
2.8	Safety and handling notice.....	8
2.9	Laser safety	8
2.9.1	Optical safety	9
2.9.2	Electrical safety	9
2.9.3	CDRH compliance	9
2.9.4	EMC mitigation measures	10
2.9.5	WEEE directive compliance.....	10
2.9.6	Specific conditions of use.....	10
2.10	Explosion hazard safety.....	11
2.11	Construction materials	11
3	Raman Rxn5 safety information	12
3.1	Construction materials	12
3.2	Protective gas.....	12
3.3	Pressurizing system	12
3.4	Purge inlet connection and purge alarm connection.....	12
3.5	Purge inlet connection.....	12
3.6	Air supply requirements	13
3.7	Commissioning	14
3.8	Operation	14
3.9	Maintenance.....	15
4	Certificates and approvals	16
4.1	Certificates and approvals – production center.....	16
4.2	Declarations of conformity – analyzers.....	16
4.3	Certificates and approvals – analyzers.....	17
4.3.1	CSA Certificate of Compliance: Raman Rxn5 analyzer	17

4.3.2	ATEX Certificate of Conformity: Raman Rxn5 analyzers.....	17
4.3.3	IECEX Certificate of Conformity: Raman Rxn5 analyzers	18
4.3.4	UKCA Certificate of Conformity: Endress+Hauser Raman analyzers	19
4.3.5	JPEX Certificate of Conformity: Endress+Hauser Raman analyzers	20
5	Hazardous area installation	22
6	Safety-related specifications	24
6.1	Base unit.....	24
6.2	Purge air supply	24

Warnings

Structure of Information	Meaning
<p> WARNING</p> <p>Causes (/consequences) Consequences of noncompliance (if applicable) ► Corrective action</p>	<p>This symbol alerts you to a dangerous situation. Failure to avoid the dangerous situation can result in a fatal or serious injury.</p>
<p> CAUTION</p> <p>Causes (/consequences) Consequences of noncompliance (if applicable) ► Corrective action</p>	<p>This symbol alerts you to a dangerous situation. Failure to avoid this situation can result in minor or more serious injuries.</p>
<p>NOTICE</p> <p>Cause/situation Consequences of noncompliance (if applicable) ► Action/note</p>	<p>This symbol alerts you to situations which may result in damage to property.</p>

Symbols

Symbol	Description
	The Laser Radiation symbol is used to alert the user to the danger of exposure to hazardous visible laser radiation when using the analyzer.
	The High Voltage symbol that alerts people to the presence of electric potential large enough to cause injury or damage. In certain industries, high voltage refers to voltage above a certain threshold. Equipment and conductors that carry high voltage warrant special safety requirements and procedures.
	The WEEE symbol indicates that the product should not be discarded as unsorted waste but must be sent to separate collection facilities for recovery and recycling.
	The CE Marking indicates conformity with health, safety, and environmental protection standards for products sold within the European economic area (EEA).
	The RCM marking indicates regulatory compliance with EESS and ACMA's labelling requirements for products sold within the Australian communications media authority (ACMA)
	The FCC mark indicates that the electromagnetic radiation from the device is below the limits specified by the Federal Communications Commission and the manufacturer has followed the requirements of the Supplier's Declaration of Conformity authorization procedures.

U.S. export compliance

The policy of Endress+Hauser is strict compliance with U.S. export control laws as detailed in the website of the [Bureau of Industry and Security](#) at the U.S. Department of Commerce.

1 Warning labels

The warning labels attached to the Raman Rxn5 are shown.

<p>WARNING</p> <p>INSTALL ONLY INTRINSICALLY SAFE FIELD WIRING BEHIND THIS PANEL</p>	<p>WARNING</p> <p>TO REDUCE THE RISK OF ELECTRIC SHOCK, THIS EQUIPMENT MUST BE USED WITH A GROUNDING-TYPE PLUG THAT HAS A THIRD (GROUNDING) PIN.</p> <p>DO NOT OPERATE RAMAN RXN5 WITHOUT GROUND CONNECTION.</p>	<p>WARNING</p> <p>RISK OF STATIC ELECTRICITY CLEAN ONLY WITH A DAMP CLOTH SOLVENTS MUST NOT BE USED</p>
<p>WARNING</p> <p>WHEN USED IN HAZARDOUS LOCATIONS, THE SAFETY OF THIS EQUIPMENT RELIES ON THE PROVISION FOR PROPER PURGING AND ADEQUATE PURGE GAS SUPPLY PRESSURE. IT MUST NOT BE PUT INTO SERVICE WITHOUT "SPECIAL PERMISSION" FROM THE INSPECTION AUTHORITY HAVING JURISDICTION.</p>	<p>WARNING</p> <p>PRESSURE ENCLOSURE</p> <p>THIS ENCLOSURE MUST NOT BE OPENED UNLESS THE AREA ATMOSPHERE IS KNOWN TO BE BELOW THE IGNITABLE CONCENTRATION OF COMBUSTIBLE MATERIALS OR UNLESS ALL DEVICES WITHIN HAVE BEEN DE-ENERGIZED.</p>	<p>WARNING</p> <p>POWER SHALL NOT BE RESTORED AFTER ENCLOSURE HAS BEEN OPENED UNTIL ENCLOSURE HAS BEEN PURGED FOR 9.5 MINUTES WITH REGULATOR PRESSURE A MINIMUM OF 1.5 psi.</p>
<p>WARNING</p> <p>BATTERIES ARE LOCATED INSIDE THIS ENCLOSURE. DO NOT OPEN WHEN AN EXPLOSIVE ATMOSPHERE IS PRESENT.</p>	<p>WARNING</p> <p>THIS ASSEMBLY CONTAINS A BATTERY MFR/TYPE: VARTA/CR2032 OR SAFT/LS 14500. REPLACEMENT BATTERIES MUST BE IDENTICAL. FAILURE TO OBSERVE THIS WARNING WILL INVALIDATE THE GOVERNING CERTIFICATES.</p>	<p>WARNING</p> <p>THIS PRESSURIZED ENCLOSURE CONTAINS A BATTERY WHICH REMAINS CONNECTED AFTER THE EXTERNAL POWER HAS BEEN ISOLATED. CONSIDERATION SHOULD BE GIVEN TO THE REMOVAL OF THE BATTERY IF THE ENCLOSURE IS TO REMAIN UNPROTECTED BY EX P FOR A SIGNIFICANT TIME.</p>
<p>CAUTION</p> <p>ELECTRIC SHOCK HAZARD</p> <p>THIS EQUIPMENT TO BE SERVICED BY TRAINED PERSONNEL ONLY</p>	<p>VISIBLE AND/OR INVISIBLE LASER RADIATION AVOID EXPOSURE TO BEAM CLASS 3B LASER PRODUCT</p> <p>THIS PRODUCT COMPLIES WITH 21 CFR SUBCHAPTER J AND IEC 60825-1:2014 ED 3</p>	

2 Basic safety instructions

2.1 Requirements for the personnel

- Installation, commissioning, operation, and maintenance of the measuring system may be carried out only by specially trained technical personnel.
- Technical personnel must be authorized by the plant operator to carry out the specified activities.
- Electrical connections may be performed only by an electrical technician.
- Technical personnel must have read and understood these Operating Instructions and must follow the instructions contained herein.
- Faults at the measuring point may only be rectified by authorized trained personnel. Repairs not described in this document must be carried out only directly at the manufacturer's site or by the service organization.

2.2 Intended use

The Raman Rxn5 analyzer is designed for use in chemical composition measurements of gases and some liquids in a process development environment.

The Raman Rxn5 is particularly suited for measuring the composition of gases at the input and output of the following process units and processes that are often found in refineries, ammonia plants, methanol plants, captive, and merchant hydrogen plants, and regasification terminals:

- Steam methane reformers
- Partial oxidation reformers
- Coal, petcoke, biomass, and waste gasifiers
- Primary and secondary shift converters
- Acid gas removal
- Methanators
- Ammonia and methanol synthesis loops
- Hydrotreaters
- Hydrocrackers
- Mixed refrigerant composition optimization

Use of the device for any purpose other than that described, poses a threat to the safety of people and of the entire measuring system and is not permitted.

2.3 Electrical safety

As the user, you are responsible for complying with the following safety conditions:

- Installation guidelines
- Local standards and regulations for electromagnetic compatibility

The product has been tested for electromagnetic compatibility in accordance with the applicable international standards for industrial applications.

The electromagnetic compatibility indicated applies only to a product that has been properly connected.

2.4 Operational safety

Before commissioning the entire measuring point:

1. Verify that all connections are correct.
2. Ensure that electrical cables and hose connections are not damaged.
3. Do not operate damaged products. Protect them against unintentional operation.
4. Label damaged products as defective.

During operation:

1. If faults cannot be rectified, products must be taken out of service and protected against unintentional operation.
2. Keep the door closed when not carrying out service and maintenance work.



CAUTION

Activities while the analyzer is in operation introduce risk of exposure to hazardous materials.

- ▶ Follow standard procedures for limiting exposure to chemical or biological materials.
- ▶ Follow workplace policies on personal protective equipment including wearing protective clothing, goggles and gloves and limiting physical access to analyzer location.
- ▶ Clean any spills following the appropriate site policies and cleaning procedures.

2.5 Product safety

The product is designed to meet local safety requirements for the intended application, and has been tested accordingly, leaving the factory in a condition in which it is safe to operate. All applicable regulations and international standards have been observed. Devices connected to the analyzer must also comply with the applicable safety standards, and users should follow the probe-specific product safety instructions. See *Laser safety* →  for additional details.

2.6 Important safeguards

- Do not use the Raman Rxn5 for anything other than its intended use.
- Do not drape the power cord over counters or on hot surfaces, or in areas where damage to the integrity of the power cord may occur.
- Do not open the enclosure of the Raman Rxn5 while it is actively collecting data.
- Do not look directly into the laser beam.
- Do not allow emitted laser light to reflect off mirrored or shiny surfaces in an uncontrolled way.
- Minimize the presence of shiny surfaces in the working area and always use a laser beam block to prevent uncontrolled transmission of the laser light.
- Do not leave attached and unused probes uncapped or unblocked while they are still attached to the analyzer.

2.7 Health and safety considerations

It is the user's responsibility to understand and comply with all applicable safety regulations. These will be variable based on the installation location of the analyzer. Endress+Hauser takes no responsibility for determining a complete list of safe operating practices at any given installation site and leaves that responsibility to the local user or owner of the equipment.

However, the following actions and laser safety precautions must always be observed while using the Raman Rxn5:

- The Raman Rxn5 is a [Center for Devices and Radiological Health \(CDRH\)](#) Class 3B device. The user should wear appropriate eye protection.
- The Raman Rxn5 should only be used in a location with a suitable and stable power supply.
- If an interlock is required to meet local safety regulations, all doors and entryways to the room or area housing the Raman Rxn5 analyzer must be fitted with clearly visible Class 3B laser area warning signs.

2.8 Safety and handling notice

Raman Rxn5 analyzers incorporate a 532 nm laser excitation source. Take the following precautions when handling the analyzer and probes when the laser is **ON**:

- Before making fiber connections and probe inspections, use the laser on/off key for the appropriate channel on the front of the Raman Rxn5 to turn **OFF** the laser power.
- Do not look directly into the fiber probe output (when the optic is disconnected) or the output (window) of any probes.

2.9 Laser safety

Laser light presents special safety hazards not associated with other light sources. All laser users, and others present, need to be aware of the special properties and dangers involved in laser radiation. Familiarity with the Raman Rxn5 and the properties of intense laser radiation will aid in the safe operation of the Raman Rxn5. The Raman Rxn5 may contain one to four 532 nm lasers. Refer to your system specification information to determine how many lasers you have, and which channels they are associated with. The combination of intense monochromatic light concentrated in a small area means that, under certain conditions, exposure to laser light is potentially hazardous. In workplace environments, a laser safety program provides environmental, training, and safety controls which may reduce the risk of laser-related injuries or workplace damage. For more assistance with taking appropriate precautions and setting the proper controls when dealing with lasers and their hazards, refer to the most current version of [ANSI Z136.1 for Safe Use of Lasers](#) or [IEC 60825-14 for Safety of laser products](#). The Raman Rxn5 analyzer has hardware safety controls to reduce the risk of laser-based injuries including an interlock and a spring-loaded protective cap covering the laser output of the fiber-optic cables.

The beam is routed from the bottom panel of the instrument via a fiber-optic cable using an industrial quality electrooptic connector. In the unlikely event that the fiber optic probe cable is removed, the interlock is overridden, and the spring-loaded protective cap is overridden, there will be a laser beam exiting the analyzer unit. The beam emerges from a fiber with core diameter of 103 μm and numerical aperture (NA) of 0.29 in.

The below table provides the fiber core size and mode and the nominal ocular hazard distance equation for the case of laser exiting directly from the analyzer unit.

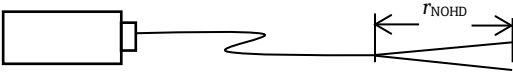
Base Unit Used	Fiber Core Size and Mode	Nominal ocular hazard distance (NOHD) Equation
		
Raman Rxn5	103 μm multi-mode (NA =0.29)	$r_{\text{NOHD}} = 1.7/\text{NA} (\Phi/\pi\text{MPE})^{1/2}$ multimode equation
MPE at 532 nm continuous viewing – $1 \times 10^{-3} \text{ W}\cdot\text{cm}^{-2}$		
Φ = Maximum Power in Watts (W)		

Another nominal hazard zone calculation needs to be performed to account for the scenario when the analyzer is equipped with a probe. Depending upon the probe utilized, the beam diameter, numerical aperture of the fiber optical cable to the probe head and focusing characteristics of the probe head, the nominal hazard zone calculation will change depending upon if the potential exposure point is at the tip of the probe or at a broken optical fiber. Refer to the specifications section in the pertinent Endress+Hauser Raman probe operating instructions for the appropriate information to complete the nominal hazard zone calculations pertaining to other exposure points.

CAUTION

- ▶ Laser beams can cause ignition of certain substances such as volatile chemicals. The two possible mechanisms for ignition are direct heating of the sample to a point causing ignition and the heating of a contaminant (such as dust) to a critical point leading to ignition of the sample.

WARNING

- ▶ The Raman Rxn5 uses a Class 3B laser as defined in [ANSI Z136.1](#). Direct eye contact with the output beam from the laser will cause severe damage and possible blindness.
- ▶ Use of controls or adjustments or performance of procedures other than those specified in this manual may result in hazardous radiation exposure.

For more assistance on appropriate precautions and setting the proper controls when dealing with lasers and their hazards, refer to the most current version of ANSI Z136.1 for Safe Use of Lasers.

2.9.1 Optical safety

The Raman Rxn5 is outfitted with 1 to 4 Class 3B lasers. Always be aware of the initial direction and possible scattering paths of the laser. The use of OD3 safety glasses is highly recommended for a 532 nm excitation wavelength.

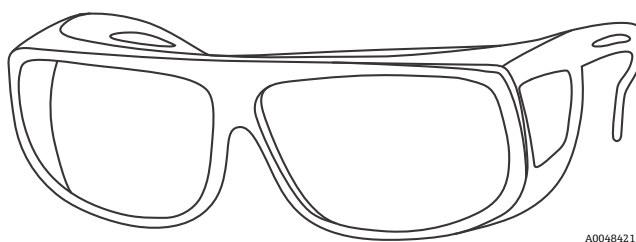

A0048421

Figure 1. Laser safety glasses

2.9.2 Electrical safety

The Raman Rxn5 utilizes AC and DC voltages inside the enclosure. Do not disassemble the laser enclosure as there are no serviceable parts inside the laser assembly. Only qualified personnel familiar with high voltage electronics should open the system enclosure to perform necessary maintenance or service.

2.9.3 CDRH compliance

The Raman Rxn5 is designed and built to meet the laser performance requirements of [U.S. 21 CFR, Chapter I, Subchapter \(J\)](#) and is registered with the CDRH.

The product report for the Raman Rxn5 can be found under accession number 1110062.

2.9.3.1 Protective housing

The Raman Rxn5 is enclosed in a protective housing to prevent human access in excess of the limits of Class I radiation as specified in U.S. 21 CFR Section 1040.10 (f) (1) except for the output, which is Class 3B.

2.9.3.2 Remote interlock connector

The Raman Rxn5 is supplied with a remote interlock connector for each channel. These connectors allow the operator to utilize an external interlock circuit in conjunction with Raman Rxn5 operations. Design and function of an external interlock circuit should meet the capability and intent of the most current revision of the [ANSI Z136.1](#) standard. No laser radiation for a particular channel is emitted unless both the fiber and remote interlock connectors are connected.

2.9.3.3 Compliance labels

The Raman Rxn5 analyzer is certified to comply with U.S. 21 CFR, Chapter I, Subchapter (J), as administered by the CDRH.

2.9.4 EMC mitigation measures

Per CFR 47 Chapter I subchapter A part 15 subpart B the Rxn5 is designed and built to meet EMC requirements for unintentional radiators with Class A limits. In areas with high Radio Frequency interference the user may see the analyzer start a self-recovery mode where the display will turn off then start again. In all cases the removal of the RF disturbances will result in the Rxn5 returning to normal operation. This also fulfills the requirement to the end-user per IEC/EN 61326

This equipment has been tested and found to comply with the limits for a Class A digital device, pursuant to part 15 of the FCC Rules. These limits are designed to provide reasonable protection against harmful interference when the equipment is operated in a commercial environment. This equipment generates, uses, and can radiate radio frequency energy and, if not installed and used in accordance with the instruction manual, may cause harmful interference to radio communications. Operation of this equipment in a residential area is likely to cause harmful interference in which case the user will be required to correct the interference at their own expense.

2.9.5 WEEE directive compliance

The Raman Rxn5 complies with the [waste electrical and electronic equipment](#) (WEEE) Directive 2012/19/EU. The WEEE Symbol shown below is placed on all WEEE-compliant assemblies.

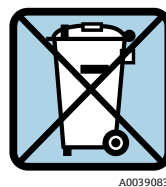

Figure 2. WEEE symbol

If no other means of disposal are available, Endress+Hauser offers a “Take Back” disposal program at no cost. To participate in the “Take Back” disposal program, refer to our website (<https://endress.com/contact>) for a list of contacts in your area.

2.9.6 Specific conditions of use

1. The fiber-optic cable linking the laser output to the probe shall be installed so that the minimum bend radius specified by the cable manufacturer is not exceeded.
2. Sometimes it is necessary to monitor the process level to ensure that the optical beam is not inadvertently exposed to a potentially explosive atmosphere. In these situations, the devices used to monitor the level shall be intrinsically safe or classed as simple apparatus and be installed so as to provide a fault tolerance of 2 for category 1 equipment. The functional safety of this arrangement has not been assessed as part of this certification and it is the responsibility of the installer or user to ensure that an appropriate mechanism is in place.
3. The user shall purge the enclosure prior to start-up and upon loss of pressurization in accordance with the instruction marks on the Raman Rxn5 enclosure. An appropriate means of isolation shall be provided by the user, appropriately certified for the area of use and correctly installed.
4. Where intrinsically safe (IS) galvanic isolators are added to the main enclosure in order to produce IS signals to external apparatus not covered by this certification, the IS galvanic isolators shall have an ambient working temperature upper limit of at least 60 °C (140 °F). The IS parameters pertaining to these isolators shall be conveyed to the user in an appropriate manner. The IS nature of any such circuits has not been assessed as part of this certification and this certificate is not to be taken as indication that these IS circuits comply with relevant requirements.

2.10 Explosion hazard safety

The Raman Rxn5 is designed for use in potentially explosive atmospheres with an output designed for use in explosive atmospheres when purged per the procedures. Usage parameter limits vary based upon the processed material and probe head used.

The Raman Rxn5 must be installed following all federal, state, and local codes for equipment located in a potentially explosive area classified as Class I, Division 2, or Zone 2. The protective gas shall not exceed 40 °C (104 °F) at the inlet to the Raman Rxn5.

2.11 Construction materials

Materials used in the construction of the Raman Rxn5 enclosure, including all sealing materials, are compatible with the chemicals that the enclosure would typically encounter in the field. The enclosure surfaces have been designed and evaluated to ensure that they do not present hazards such as static buildup.

3 Raman Rxn5 safety information

3.1 Construction materials

Materials used in the construction of the Raman Rxn5 enclosure, including all sealing materials, are compatible with the chemicals that the enclosure would typically encounter in the field. The enclosure surfaces have been designed and evaluated to ensure that they do not present hazards such as static buildup.

3.2 Protective gas

The protective gas shall be essentially free of contaminants or foreign matter and shall contain no more than trace amounts of flammable gas or vapor. If using compressed air, the air intake of the compressor must be located in a non-hazardous zone. The temperature of the protective gas shall not exceed 40 °C (104 °F).

WARNING

- ▶ The protective gas supply shall have an alarm that is located at a constantly attended location.
- ▶ Power must not be restored after enclosure has been opened until enclosure has been purged for 9.5 minutes with a minimum pressure of 2.0 psi as read at the inlet regulator.
- ▶ FOLLOW INSTRUCTIONS BEFORE CLOSING THE PROTECTIVE GAS SUPPLY VALVE.

If the protective gas supply to this enclosure has an isolation valve, that valve must have the following label:

PROTECTIVE GAS SUPPLY VALVE – This valve must be kept open unless the area atmosphere is known to be below the ignitable concentration of combustible materials, or unless all equipment within the protected enclosure is de-energized.

NOTICE

- ▶ The protective gas pressure shall be set between 2.0 and 2.5 psig (0.13 and 0.17 barg) at the inlet regulator. Pressure below 2.0 psig will result in inadequate purge rates.
- ▶ Pressure above 2.5 psig may result in exceeding the maximum rated overpressure as specified on the nameplate.
- ▶ Inlet pressure must be monitored at all times during the purging operation.

3.3 Pressurizing system

Refer to the [Purge Solutions CYCLOPS Z- Purge Indicator IOM manual](#) for additional information on installation, operating, and maintenance instructions for the pressurizing system. For ease of use it is recommended that the installation instructions are utilized.

3.4 Purge inlet connection and purge alarm connection

The purge indicator installed on the Raman Rxn5 analyzer is of the Z-Purge variety from Purge Solutions, Inc. The indicator is certified for use in Division 2/Zone 2 hazardous areas. The Z-purge indicator has a green indicator light that indicates that the pressure inside the enclosure is above 0.20" water column. The indicator provides a dry contact alarm relay for a remote alarm if needed; it is the installer's and/or customer's responsibility to interface to the alarm contacts.

3.5 Purge inlet connection

The Z-Purge indicator is paired with a Purge Solutions manual leakage compensation valve. There are 2 modes of operation for the valve—dilution and leakage compensation. For purging, the dial on the valve should be turned so the slot in the dial is horizontal and lined up with the "ON" position. Once the purging has been performed for the specified time, the valve may be switched to the leakage compensation mode by turning the dial so the slot in the dial is vertical. Leakage compensation mode allows the enclosure to remain pressurized with a much smaller usage of air after the purging has occurred.

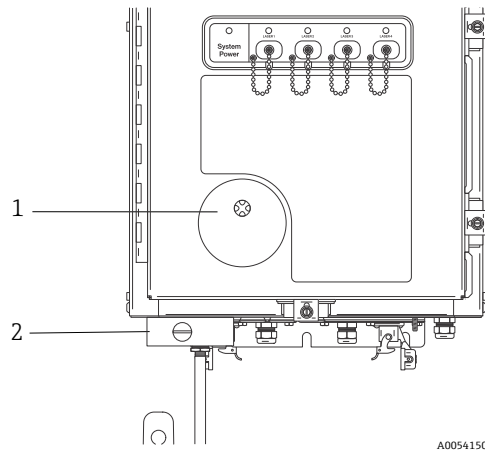

Figure 3. Purge indicator and valve system

#	Description
1	Z-Purge indicator
2	Manual leakage compensation valve

The Raman Rxn5 is shipped without the purge regulator and filter assembly installed. It is the installer’s responsibility to install the purge regulator and filter assembly and interface the air supply to the assembly. The inlet to the filter is ¼-18 NPT. Use appropriate thread sealant.

3.6 Air supply requirements

- **Inlet Fitting.** ¼-18 NPT.
- **ISA Grade.** Hydrocarbon free.
- **Water and Oil Free.** -40 °C (-40 °F) dew-point.
- **Particle Size.** 5 micron maximum.
- **Pressure Range.** 3.45 to 8.27 bar (50 to120 psi).
- **Max Flow Rate for Purging.** 56.63 SLPM (2.0 SCFM).
- **Max Flow Rate for Leakage Compensation.** 21.24 SLPM (0.75 SCFM).

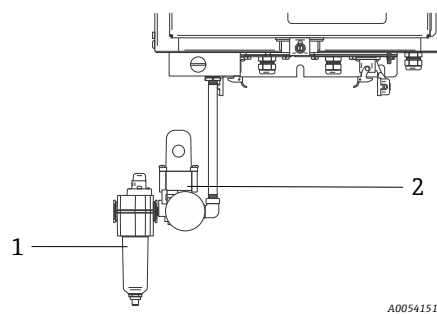

Figure 4. Purge regulator and filter assembly

#	Description
1	Filter
2	Regulator and gauge

NOTICE

- ▶ Commissioning of the system is required to validate that the protective gas supply system is functioning properly after initial installation. This procedure must be followed after initial installation and after any maintenance operation requiring removal or replacement of protective gas system components.
- ▶ The procedure must be followed after initial commissioning is complete and any operation requiring opening the enclosure is performed. This procedure must be followed prior to re-energizing the system.

3.7 Commissioning

Commissioning is required to verify that the air supply will provide an adequate flow during purging and that the minimum internal overpressure is maintained when in the leakage compensation mode (the dial on the valve is turned so the slot in the dial is vertical).

1. Verify that a flammable atmosphere is not present.
2. Tighten door clamps in five places with a flat blade screwdriver or 3/8" nut driver to ensure proper seal.
3. Verify cable glands on all I/O connections are tight.
4. Apply protective gas to inlet filter assembly.
5. Turn the dial on the valve so the slot is in the horizontal ON position.
6. Verify that the regulator pressure is no less than 13.78 kPa (2.0 psi). If the pressure is less than 10.34 kPa (1.5 psi), adjust to obtain 10.34 kPa (1.5 psi) and tighten the locknut. If this pressure cannot be obtained then there is excessive pressure drop in the air supply lines and either the supply pressure must be increased or larger air lines installed.
7. Apply power to analyzer and verify the indicator light is Green.
8. Turn the dial on the valve so the slot is vertical OFF position.
9. Verify the indicator light is still Green. If the indicator is no longer green, then there is excessive leakage from the enclosure. The source of the leakage must be found and corrected.

3.8 Operation

The purge regulator has been pre-set at the factory to 0.148 bar (2.15 psi) during the purging. It may be necessary to reset the operating pressure at installation. The normal operating range for the regulator is 0.14 to 0.17 bar (2.0 to 2.5 psi) during purging (**ON** position). Operating in the pressure range will ensure appropriate air flow into the enclosure.

After commissioning has taken place, any time the enclosure is opened, before being put into service, take the following steps:

1. Tighten the door clamps in five places with a flat blade screwdriver or 3/8" nut driver to ensure a proper seal.
2. Apply air to inlet filter assembly.
3. Turn the dial on the valve to the ON position.
4. Purge for a minimum of 9.5 minutes.
5. Apply power to analyzer and observe the indicator light. If the indicator light turns on, turn the valve to the leakage compensation position if desired and observe the indicator light.
6. If at any time, the indicator light does not light up, there is a leak and power should be removed from the analyzer while the source of the leak is found and corrected and the 9.5 minute purge should be repeated before re-applying power.

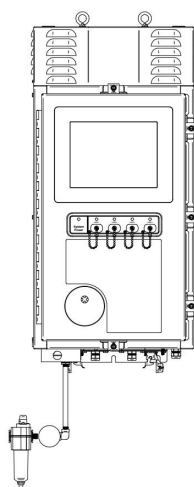

Figure 46. Door closure points

3.9 Maintenance

 **WARNING**

The Raman Rxn5 must be located in a non hazardous zone in order for maintenance to safely take place. You should also make sure the Raman Rxn5 is shut down and cooled before attempting to open it to perform internal maintenance.

4 Certificates and approvals

4.1 Certificates and approvals – production center

Document	Document Number	Products / Processes	Standards / Requirements
ISO 14001:2015 Declaration of Conformance	4002039 (manufacturer)	Manufacture of Raman Spectrographic Instruments including Software; Specialty Holographic Assemblies, Elements and Components	ISO 14001:2015
ISO 9001:2015 Certificate	Certificate Registration No. 74 300 2705	Design and Manufacture of Raman Spectrographic Instruments including Software; Specialty Holographic Assemblies, Elements and Components	ISO 9001:2015
Quality assurance notification (QAN) Raman Analyzers and Probes	Certificate Registr. No. 01 220 093059	Production, final inspection and testing of Endress+Hauser Rxn* Analyzer base units and Rxn-20, Rxn- 30, Rxn-40, and Rxn-41 Probes Types of protection: "p", "I", "op is"	Directive 2014/34/EU Annex IV
IECEx Quality assessment report (QAR) Certificate	QAR Reference No. DE/TUR/QAR11.0001/XX* Related Certificates for previous versions	Endress+Hauser, Analyzer Base Units, Rxn-20, Rxn-30, and Rxn-40 probes Protection concept Pressurized enclosures "p";; Intrinsic safety "I";; Optical radiation "op is"	Related QARs DE/TUR/QAR11.0001/00 DE/TUR/QAR11.0001/01 DE/TUR/QAR11.0001/02 DE/TUR/QAR11.0001/03

*The last two numbers change depending on the newest report.

4.2 Declarations of conformity – analyzers

Document (Manufacturer Doc #)	Products	Regulations	Standards	Certification
ATEX Declaration of Conformity - Raman Rxn5 Analyzer	Raman Rxn5, RXN5	European Directives: EMC 2014/30/EU ATEX 2014/34/EU LVD 2014/35/EU RoHS 2011/65/EU	Applied harmonized standards or normative documents: IEC 61010 : 1 2010 EN IEC 60079-0 : 2018 EN 60079-2 : 2015 EN 60079-11 : 2012 EN IEC 60079-7 : 2015 +A1 :2018 EN 60079-28 : 2015 EN 50495 : 2010 EN IEC 61326 : 2021	CE-Type Examination Certificate No. CSANe 22ATEX 1097 X issued by CSA(2813) Quality assurance TÜVRheinland (0035)

4.3 Certificates and approvals – analyzers

Revision date of applicable standards and list: Protective Device Safety Certification Notice No. 2021-22.

4.3.1 CSA Certificate of Compliance: Raman Rxn5 analyzer

The Raman Rxn5 analyzer has been approved for use in hazardous areas in the United States and Canada by the [Canadian Standards Association](#) when installed in accordance with the Hazardous Area Installation Drawing (4002396).

The products listed are eligible to bear the CSA Mark shown with adjacent indicators 'C' and 'US' for Canada and US (indicating that products have been manufactured to the requirements of both Canadian and U.S. Standards) or with adjacent indicator 'US' for US only or without either indicator for Canada only.



Figure 5. Label showing equipment is approved for use in hazardous areas in the United States and Canada

Products:	Raman Rxn5 analyzer CLASS - C225804 - PROCESS CONTROL EQUIPMENT-Intrinsically Safe, Entity - For Hazardous Locations CLASS - C225884 - PROCESS CONTROL EQUIPMENT - Intrinsically Safe, Entity - For Hazardous Locations - Certified to US Standards
Marking:	Raman Rxn5 analyzer Class I, Division 2, Groups B, C, or D, T4 Class I, Zone 2; IIB + H ₂ , T4
Tambient:	– 20 to 50 °C (–4 to 122 °F)

Conditions of certification:

None

Applicable requirements/standards:

- [CAN/CSA Standard C22.2 No. 0-10](#) Tenth Edition (2010) General Requirements – Canadian Electrical Code, Part II
- [CAN/CSA Standard C22.2 No.157-92](#) Third Edition (Reaffirmed 2006) Intrinsically Safe and Non-Incendive Equipment for Use in Hazardous Locations
- [CSA LTR E-010-2005](#) Purged and Pressurized Enclosures for Use in Class I, Division 1 or 2 Hazardous Locations
- [CAN/CSA-C22.2 No. 61010-1-12](#) (Third Edition) Safety requirements for electrical equipment for measurement, control, and laboratory use – Part 1: General requirements
- [NFPA 496:2008](#) Standard for Purged and Pressurized Enclosures for Electrical Equipment
- [UL Standard 913](#) (Sixth Edition) Intrinsically Safe Apparatus and Associated Apparatus for Use in Class I, II, and III, Division 1, Hazardous (Classified) Locations
- [UL 61010-1](#), May 11, 2012 (Third Edition) Electrical Equipment For Measurement, Control, and Laboratory Use; Part 1: General Requirements
- [CSA Standard C22.2 No. 14](#) Eleventh Edition (2010) Industrial Control Equipment
- [CSA Standard C22.2 No.142-M1987](#) Third Edition (Reaffirmed 2009) Process Control Equipment Industrial Products
- [UL Standard 916](#) (Fourth Edition) Energy Management Equipment

NOTICE

Handle probes and cables with care.

- ▶ Fiber cables should NOT be kinked and should be routed to maintain the minimum bend radius of 152.4 mm (6 in).
- ▶ Permanent damage to the cables may result if they are bent beyond the minimum radius.

4.3.2 ATEX Certificate of Conformity: Raman Rxn5 analyzers

The Raman Rxn5 analyzer have been third-party approved for use in hazardous areas in accordance with certifies that this equipment or protective system has been found to comply with the Essential Health and Safety Requirements relating to the design and construction of equipment and protective systems intended for use in potentially explosive atmospheres given in Annex II to the Directive.



Figure 6. ATEX label for use in hazardous areas

Products:	Raman Rxn5 Analyzer
Marking:	Ex ec ic [ia Ga] [op sh Gb] pzc IIC T4 Gc CE 0035  3(2)(1) G
Tambient:	–20 to 50 °C (–4 to 122 °F)

Conditions of certification:

1. The fiber-optic cable linking the laser output to the probe shall be installed so that the minimum bend radius specified by the cable manufacturer is not exceeded.
2. Where it is necessary to monitor the process level to ensure that the optical beam is not exposed to a potentially explosive atmosphere, the devices used to monitor the level shall be intrinsically safe or classed as simple apparatus and be installed so as to provide a fault tolerance of 2 for category 1 equipment. The functional safety of this arrangement has not been assessed as part of this certification and it is the responsibility of the installer I user to ensure that an appropriate mechanism is in place.
3. The user shall purge the enclosure prior to start-up and upon loss of pressurization in accordance with the instruction marks on the Raman Rxn5 enclosure. An appropriate means of isolation shall be provided by the user, appropriately certified for the area of use and correctly installed.
4. Where IS galvanic isolators are added to the main enclosure in order to produce IS signals to external apparatus not covered by this certification, the IS galvanic isolators shall have an ambient working temperature upper limit of at least 60°C (140°F). The IS parameters pertaining to these isolators shall be conveyed to the user in an appropriate manner. The IS nature of any such circuits has not been assessed as part of this certification and this certificate is not to be taken as indication that these IS circuits comply with relevant requirements.

Applicable requirements/standards:

Compliance with the Essential Health and Safety Requirements has been assured by compliance with:

- EN 60079-0:2012
- EN IEC 60079-0 : 2018
- EN 60079-2 : 2015
- EN 60079-11 : 2012
- EN IEC 60079-7 : 2015 +A1 :2018
- EN 60079-28 : 2015
- EN 50495 : 2010

NOTICE

Handle probes and cables with care.

- ▶ Fiber cables should NOT be kinked and should be routed to maintain the minimum bend radius of 152.4 mm (6 in).
- ▶ Permanent damage to the cables may result if they are bent beyond the minimum radius.

4.3.3 IECEx Certificate of Conformity: Raman Rxn5 analyzers

The Raman Rxn5 analyzer can also be marked for [International electrotechnical commission](#) (IEC) Certification Systems for Explosive Atmospheres when installed in accordance with the Hazardous Area Installation Drawing (4002396).

Product:	Raman Rxn5 Analyser
Marking:	Ex ec ic [ia Ga] [op sh Gb] pzc IIC T4 Gc IECEx CSAE 22.0067X
Tambient:	–20 to 50 °C (–4 to 122 °F)

Conditions of certification:

1. The fiber-optic cable linking the laser output to the probe shall be installed so that the minimum bend radius specified by the cable manufacturer is not exceeded.
2. Where it is necessary to monitor the process level to ensure that the optical beam is not exposed to a potentially explosive atmosphere, the devices used to monitor the level shall be intrinsically safe or classed as simple apparatus and be installed so as to provide a fault tolerance of 2 for EPL Ga equipment or a fault tolerance of 1 for EPL Gb equipment. The functional safety of this arrangement has not been assessed as part of this certification and it is the responsibility of the installer / user to ensure that an appropriate mechanism is in place.
3. The user shall purge the enclosure prior to start-up and upon loss of pressurization in accordance with the instructions marked on the Raman Rxn5 enclosure. An appropriate means of isolation shall be provided by the user, appropriately certified for the area of use and correctly installed.
4. Where IS Galvanic isolators are added to the main enclosure in order to produce IS signals to external apparatus not covered by this certification, the IS galvanic isolators shall have an ambient working temperature upper limit of at least 60 °C (140 °F). The IS parameters pertaining to these isolators shall be conveyed to the user in an appropriate manner. The IS nature of any such circuits has not been assessed as part of this certification and this certificate is not to be taken as indication that these IS circuits comply with relevant requirements.

Applicable requirements/standards:

The electrical apparatus and any acceptable variations to it specified in the schedule of this certificate and the identified documents, was found to comply with the following standards:

- IEC 60079-0:2017
- IEC 60079-11:2011
- IEC 60079-2:2014-07
- IEC 60079-28:2015
- IEC 60079-7:2017

NOTICE**Handle probes and cables with care.**

- ▶ Fiber cables should NOT be kinked and should be routed to maintain the minimum bend radius of 152.4 mm (6 in).
- ▶ Permanent damage to the cables may result if they are bent beyond the minimum radius.

4.3.4 UKCA Certificate of Conformity: Endress+Hauser Raman analyzers

The Raman Rxn5 analyzer has been third-party approved for use in hazardous areas in accordance with Regulation 42 of the Equipment and Protective Systems Intended for Use in Potentially Explosive Atmospheres Regulations 2016, UKSI 2016:1107.



Figure 7. UK product certification label

Products:	Raman Rxn5 Analyzer
Marking:	Ex ec ic [ia Ga] [op sh Gb] pzc IIC T4 Gc CE 0035 UKCA II 3(2)(1) G
Tambient:	– 20 to 50 °C (– 4 to 122 °F)

Applicable requirements/standards:

Compliance with the Essential Health and Safety Requirements has been assured by compliance with:

- EN IEC 60079-0:2018
- EN 60079-11:2012
- EN 60079-28:2015
- EN 50495:2010

Conditions of certification:

1. The fiber-optic cable linking the laser output to the probe shall be installed so that the minimum bend radius specified by the cable manufacturer is not exceeded.
2. Where it is necessary to monitor the process level to ensure that the optical beam is not exposed to a potentially explosive atmosphere, the devices used to monitor the level shall be intrinsically safe or classed as simple apparatus and be installed so as to provide a fault tolerance of 2 for EPL Ga equipment or a fault tolerance of 1 for EPL Gb equipment. The functional safety of this arrangement has not been assessed as part of this certification and it is the responsibility of the installer / user to ensure that an appropriate mechanism is in place.
3. The user shall purge the enclosure prior to start-up and upon loss of pressurization in accordance with the instructions marked on the Raman Rxn5 enclosure. An appropriate means of isolation shall be provided by the user, appropriately certified for the area of use and correctly installed.
4. Where IS galvanic isolators are added to the main enclosure in order to produce IS signals to external apparatus not covered by this certification, the IS galvanic isolators shall have an ambient working temperature upper limit of at least 60 °C (140 °F). The IS parameters pertaining to these isolators shall be conveyed to the user in an appropriate manner. The IS nature of any such circuits has not been assessed as part of this certification and this certificate is not to be taken as indication that these IS circuits comply with relevant requirements.

NOTICE

Handle probes and cables with care.

- ▶ Fiber cables should NOT be kinked and should be routed to maintain the minimum bend radius of 152.4 mm (6 in).
- ▶ Permanent damage to the cables may result if they are bent beyond the minimum radius.

4.3.5 JPEX Certificate of Conformity: Endress+Hauser Raman analyzers

The Raman Rxn5 analyzer has been third-party approved for use in hazardous areas in and been found to comply when installed in accordance with the Hazardous Area Installation Drawing (4002396).

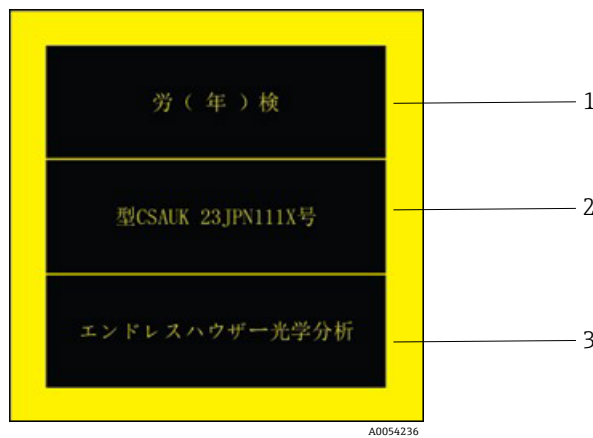

Figure 8. JPEX label for use in hazardous areas

#	Name
1	Date of approval year (Japanese calendar) and month
2	Certificate number
3	Number of manufacturer

Products: Raman Rxn5 Analyzer

Marking: Ex ec ic [ia Ga] [op sh Gb] pzc IIC T4 Gc

Tambient: -20 to 50 °C (-4 to 122 °F)

Conditions of certification:

1. The fiber-optic cable linking the laser output to the probe shall be installed so that the minimum bend radius specified by the cable manufacturer is not exceeded.
2. Where it is necessary to monitor the process level to ensure that the optical beam is not exposed to a potentially explosive atmosphere, the devices used to monitor the level shall be intrinsically safe or classed as simple apparatus and be installed so as to provide a fault tolerance of 2 for EPL Ga equipment or a fault tolerance of 1 for EPL Gb equipment. The functional safety of this arrangement has not been assessed as part of this certification and it is the responsibility of the installer / user to ensure that an appropriate mechanism is in place.
3. The user shall purge the enclosure prior to start-up and upon loss of pressurization in accordance with the instructions marked on the Raman Rxn5 enclosure. An appropriate means of isolation shall be provided by the user, appropriately certified for the area of use and correctly installed.
4. Where IS galvanic isolators are added to the main enclosure in order to produce IS signals to external apparatus not covered by this certification, the IS galvanic isolators shall have an ambient working temperature upper limit of at least 60°C (140°F). The IS parameters pertaining to these isolators shall be conveyed to the user in an appropriate manner. The IS nature of any such circuits has not been assessed as part of this certification and this certificate is not to be taken as indication that these IS circuits comply with relevant requirements.

Applicable requirements/standards:

Compliance with the Essential Health and Safety Requirements has been assured by compliance with:

- [IEC 60079-0:2017](#)
- [IEC 60079-11:2011](#)
- [IEC 60079-2:2014-07](#)
- [IEC 60079-28:2015](#)
- [IEC 60079-7:2017](#)

NOTICE**Handle probes and cables with care.**

- ▶ Fiber cables should NOT be kinked and should be routed to maintain the minimum bend radius of 152.4 mm (6 in).
- ▶ Permanent damage to the cables may result if they are bent beyond the minimum radius.

5 Hazardous area installation

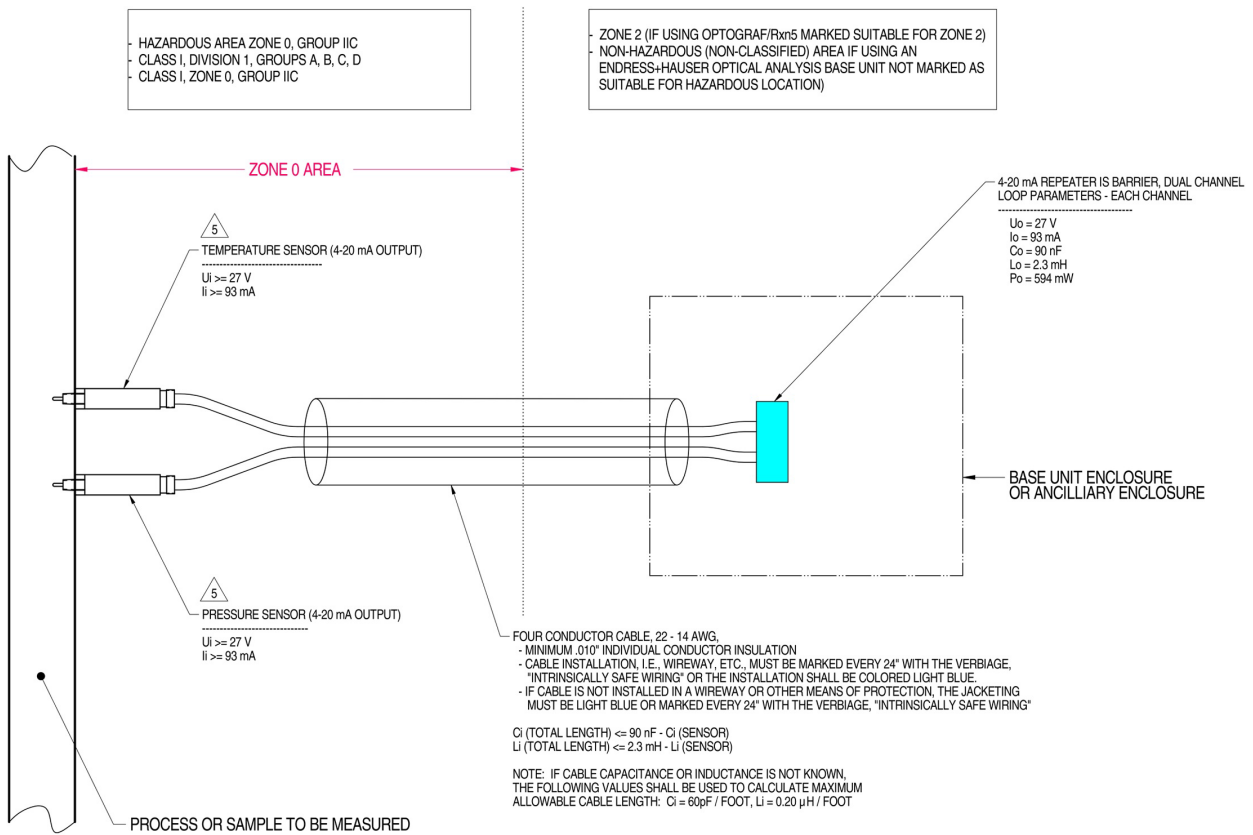

MATERIAL: NA
FINISH: NA

NOTES: 1) CONTROL EQUIPMENT CONNECTED TO THE ASSOCIATED APPARATUS MUST NOT USE OR GENERATE MORE THAN 250 VRMS OR VDC.

2) INSTALLATION IN THE U.S. SHOULD BE IN ACCORDANCE WITH ANSI/ISA RP12.6 "INSTALLATION OF INTRINSICALLY SAFE SYSTEMS FOR HAZARDOUS (CLASSIFIED) LOCATIONS" AND THE NATIONAL ELECTRICAL CODE® (ANSI/NFPA 70) SECTIONS 504 AND 505.

3) INSTALLATION IN CANADA SHOULD BE IN ACCORDANCE WITH THE CANADIAN ELECTRICAL CODE, CSA C22.1, PART 1, APPENDIX F.

4) ASSOCIATED APPARATUS MANUFACTURER'S INSTALLATION DRAWING MUST BE FOLLOWED WHEN INSTALLING THIS EQUIPMENT

5) THE TEMPERATURE AND PRESSURE SENSORS MUST BE ENTITY APPROVED FOR CLASS I, ZONE 0, IIC OR CLASS I DIVISION 1, GROUPS A, B, C, D.

6) NO REVISION TO DRAWING WITHOUT PRIOR CSA-INTERNATIONAL APPROVAL.

7) WARNING: SUBSTITUTION OF COMPONENTS MAY IMPAIR INTRINSIC SAFETY.

8) SYSTEM MAY BE COMPRISED OF MULTIPLE CHANNELS, EACH WITH ITS OWN CABLE, TEMPERATURE AND PRESSURE SENSOR AND ASSOCIATED 4-20 mA REPEATER IS BARRIER

A0050082

Figure 9. Control drawing for temperature and pressure I.S. circuit (2012682 X7)

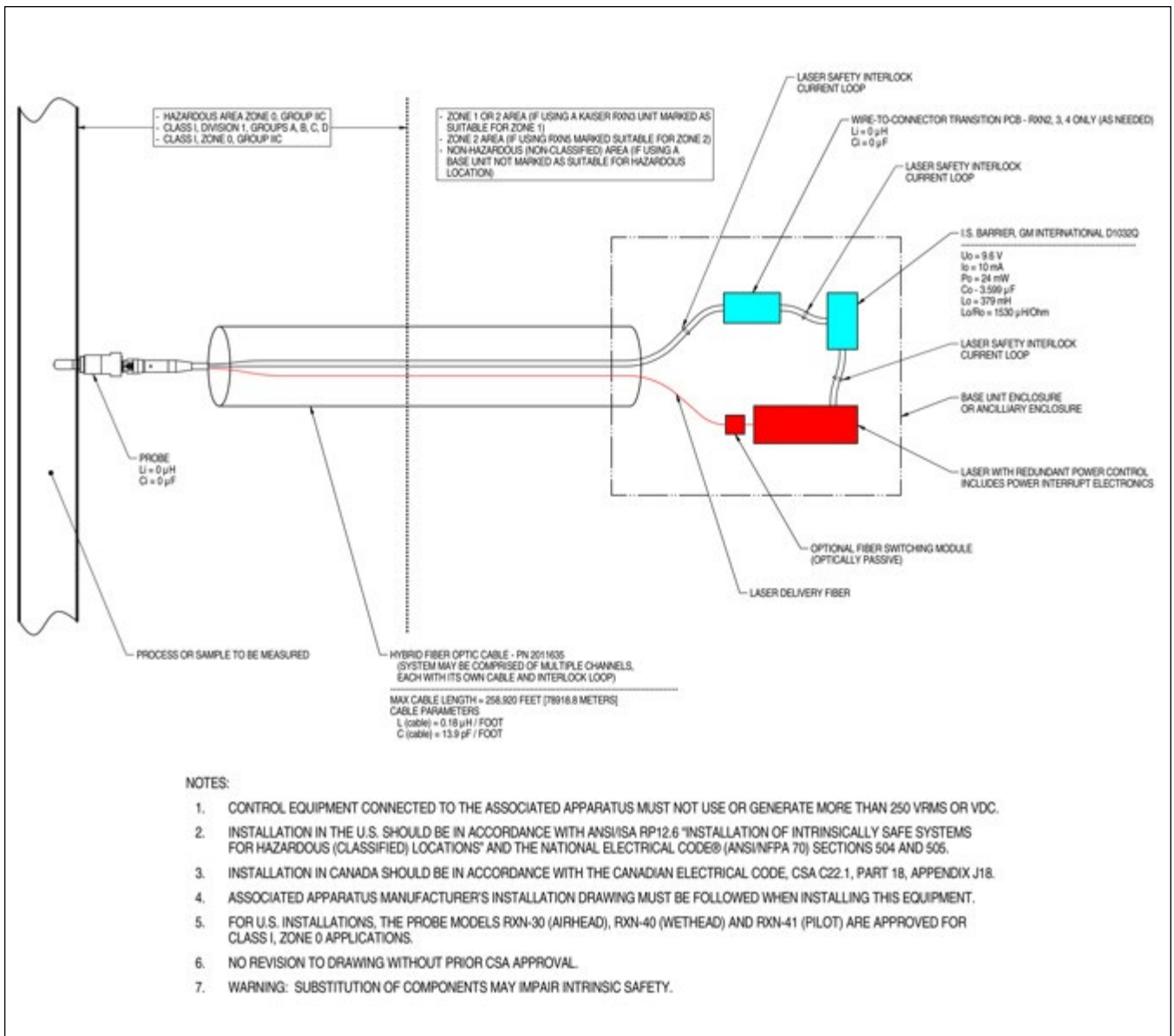

Figure 10. Control drawing for probe I.S. circuit (4002396 X6)

A0049010

6 Safety-related specifications

The following are specifications for the Raman Rxn5 analyzer. Specifications may change without notice.

6.1 Base unit

Item	Description
Operating temperature (base unit)	-20 to 50 °C (-4 to 122 °F)
Operating temperature (cable and connector)	-40 to 80 °C (-40 to 176 °F)
Operating humidity	0 to 90 % RH non-condensing
Environmental temp range	-20 to 50 °C (-4 to 122 °F) solid state cooling – no vortex or external cooling
Input voltage	AC 100 to 240 V, 50 to 60 Hz standard
Max power	< 300 W max (startup), 200 W typical
Sound level (from operator's perspective)	60.1 dB max, A-weighted
Ingress protection rating	IP54

6.2 Purge air supply

Item	Description
Purge air maximum temperature	40 °C (104 °F)
Purge air dewpoint	-40 °C (-40 °F)
Purge air pressure range	1.38 to 8.27 bar (20 to 120 psi)

www.addresses.endress.com
