

Special Documentation

IEC 61406

Automatic identification of physical objects



Table of contents

1	Introduction	4
2	Tagging options according to IEC 61406-1 for field devices	5
2.1	Metal TAG	5
2.2	NFC TAG	5
3	Ordering information	6
4	Data content	7
5	Access to data and information	8
5.1	Reading the metal TAG (optically)	8
5.2	Reading data from an NFC TAG (electromagnetic)	8
5.3	Tooling	9
6	Technical data	10
6.1	Metal TAG	10
6.2	NFC TAG	10
7	Maintenance	12
8	Accessories and Spare Parts	13

1 Introduction

"Automatic identification of physical objects"

To enable maintenance work to be organized as efficiently as possible, all components installed in a plant must be clearly identifiable. Approximately 30 companies from the process industry have joined forces to develop a global standard for this purpose. The result is the IEC 61406-1 standard. It describes a globally unique, machine-readable ID that is applied to a physical object—similar to a nameplate or label—and facilitates the identification of plant equipment. This will enable mobile devices to recognize the equipment in a plant, thus ensuring that production employees are provided with the appropriate information and maintenance schedules directly on site.

2 Tagging options according to IEC 61406-1 for field devices

2.1 Metal TAG

The IEC option is available as an additional tagging option. If the IEC option is selected, this always contains the metal TAG. The metal TAG shows the data matrix code, which includes a globally unique URL to the corresponding device.

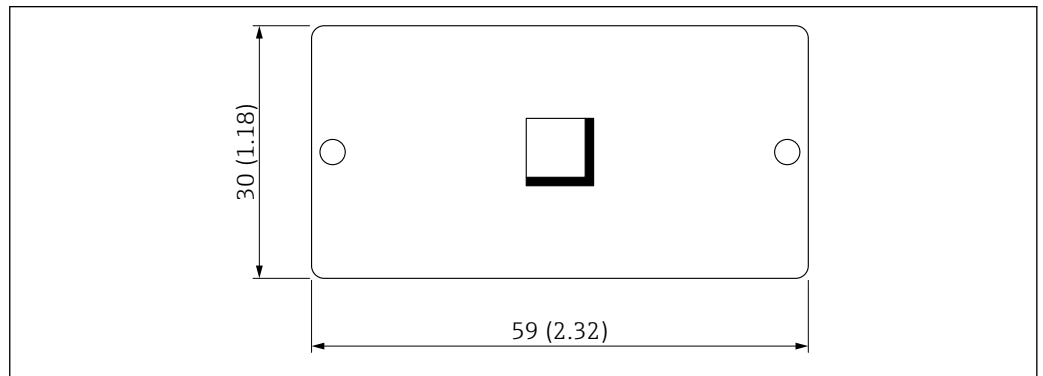

A0045999

Unit of measurement mm (in)

2.2 NFC TAG

An NFC TAG can be selected as an option in addition to the metal TAG. An NFC TAG is particularly suitable for use in harsh and difficult conditions. It can ensure readability over a long period of time. The NFC TAG can be used if this does not limit the specification of the field device, e.g. ambient temperature.

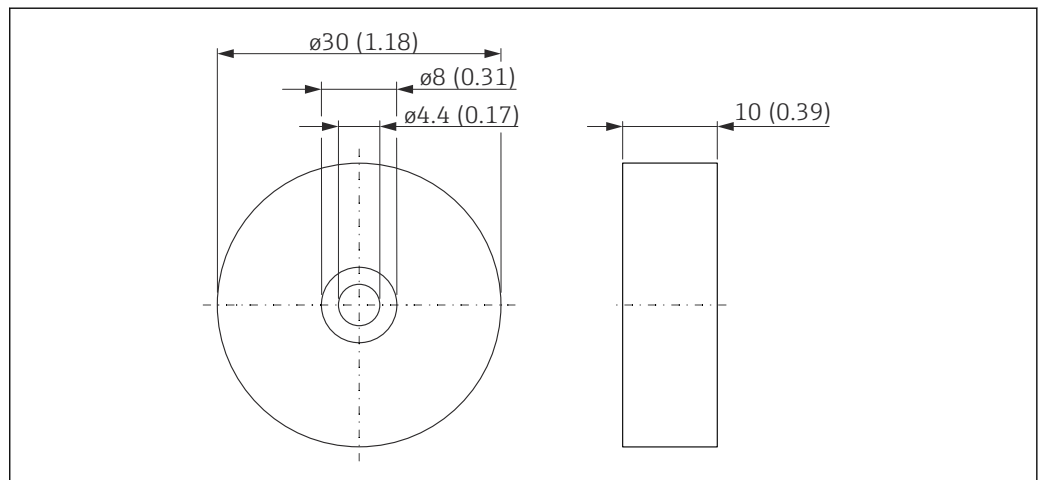

A0026580

Unit of measurement mm (in)

3 Ordering information

Detailed ordering information is available from your nearest sales organization www.addresses.endress.com or in the Product Configurator at www.endress.com:

1. Select the product using the filters and search field.
2. Open the product page.
3. Select **Configuration**.



Product Configurator - the tool for individual product configuration

- Up-to-the-minute configuration data
- Depending on the device: direct input of information specific to the measuring point, such as the measuring range or operating language
- Automatic verification of exclusion criteria
- Automatic creation of the order code and its breakdown in PDF or Excel output format
- Ability to order directly in the Endress+Hauser Online Shop

4 Data content

With the introduction of the IEC 61406-1 standard, a unique tag is defined for each device. This tag is assigned to the device throughout its entire life cycle. A tag for a device based on IEC 61406 -1 does not constitute a device tag.

For Endress+Hauser field devices, the format of the unique TAG of a device is as follows:
[https://dsp.endress.com/serial/"serial_number"](https://dsp.endress.com/serial/)

Example: For Endress+Hauser field devices with serial number M304A10109C, the corresponding TAG is: <https://dsp.endress.com/M304A10109C>

The content of a metal TAG and an NFC TAG for the device is identical.

5 Access to data and information

- i** ▪ Internet access is required to access data provided by Endress+Hauser.
- The user gets access to general information about the device in question.
- The information can be read out optically via the metal TAG or via NFC technology from the NFC TAG.

5.1 Reading the metal TAG (optically)

The stored data content can be read using 2D matrix code terminals. These include mobile terminals with a corresponding app that supports the reading of 2D matrix codes.

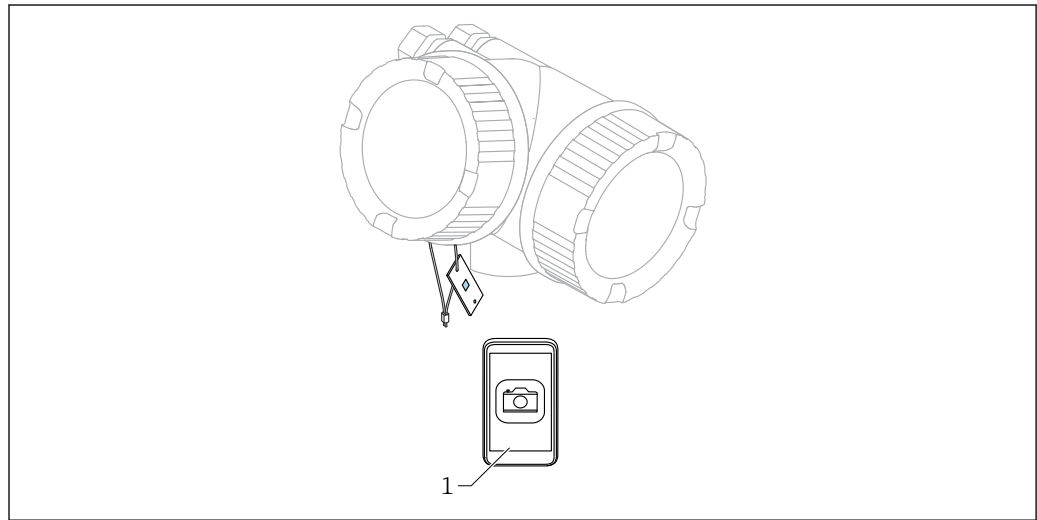

A0046001

1 Mobile terminal with app that supports the reading of 2D matrix codes

5.2 Reading data from an NFC TAG (electromagnetic)

The stored data content can be read using NFC-enabled terminals.

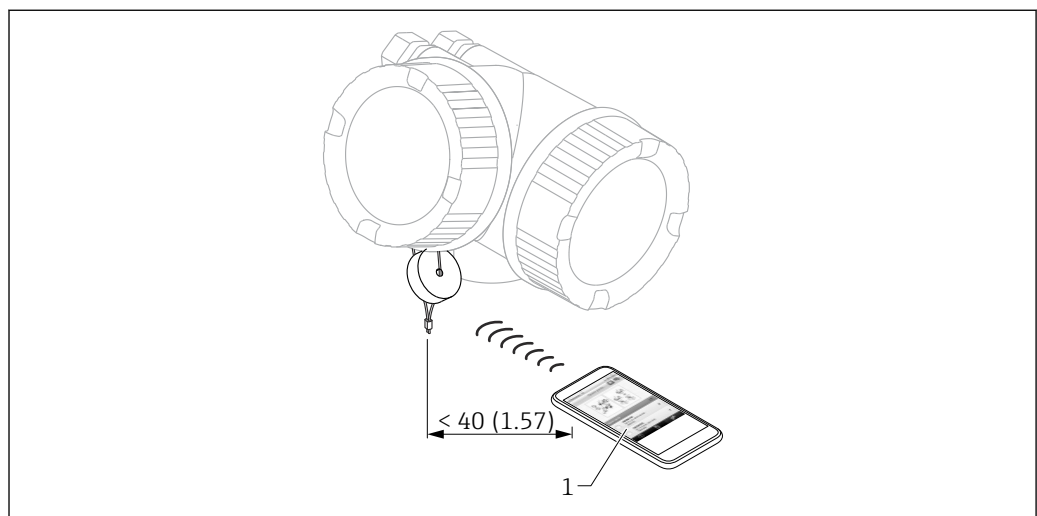

A0026587

i 1 Measurement unit: mm (in)

1 Mobile device that supports NFC

- i** The communication distance between the NFC TAG and the terminal must not exceed 40 mm (1.57 in).

5.3 Tooling

5.3.1 Metal TAG

The stored data content can be read using 2D matrix code terminals. These include mobile terminals with a corresponding app that supports the reading of 2D matrix codes.

5.3.2 NFC TAG

The stored data content can be read using NFC-enabled terminals.

6 Technical data

6.1 Metal TAG

6.1.1 General

- Material:
 - 1.4404 as per DIN EN 10088
 - 316L as per AISI
- Dimensions: 59 x 30 x 0.8 mm (2.32 x 1.18 x 0.03 in)

6.2 NFC TAG

6.2.1 General

- Operating frequency: 13.56 MHz
- Transmission rate: 106 kBit/s
- Communication: ISO/IEC 14443, type A, NFC Forum type 2, text
- Data content: NDEF message format

6.2.2 Mechanical data

- Degree of protection: IP66/68 (24 h at 1.83 m (6 ft) under water)
- Housing material: polyurethane (PUR - 3 components)
- Degree of hardness of housing: 60 to 65 shore D acc. to ASTM D 2240 SE 004
- Weight: 8 g (0.282 oz)
- Color:
 - Standard: anthracite (RAL 7016)
 - Ex version: light blue (RAL 5012)

6.2.3 Memory

- Chip type: NTAG216 (NXP)
- Type/size: EEPROM 888 byte, ROM 36 byte
- Read cycles: no limit
- Write cycles: 100 000 cycles (at +22 °C (+72 °F))
- Data retention: 10 years (at +22 °C (+72 °F))

6.2.4 Environment

- Permitted storage temperature: -55 to +130 °C (-67 to +266 °F)
- Permitted operating temperature: -55 to +80 °C (-67 to +176 °F)
- Ex ambient temperature: -50 °C (-58 °F) ≤ Ta ≤ +70 °C (+158 °F)
- Climate class: 4K4H; as per EN 60721-3-4:1995
- Salt spray and seawater: visually OK, as per ASTM B 117 to 240 h
- Humidity test: visually OK after 240 h
- UV resistance: > 4 gray scale, as per SAE J 2020
- Flammability: UL94-HB
- EMC immunity: ≤12 V/m (at 80 to 6 000 MHz)
- ESD capability: non-critical

6.2.5 Approvals



The following approvals apply only to the Ex version of the NFC TAG (light blue).

ATEX

- II2G Ex ia IIC T6/T4 Gb
- II2D Ex ia IIIC T80°C/T130°C Db
- Certificate number: EPS 15 ATEX 1 1011 X

IECEX

- Ex ia IIC T6/T4 Gb
- Ex ia IIIC T80°C/T130°C Db
- Certificate number: IECEX EPS 15.0042X

UKCA Ex

- II 2G Ex ia IIC T6/T4 Gb
- II 2D Ex ia IIIC T80°C/T130°C Db
- Certificate number: EPS 22 UKEX 1 086 X

6.2.6 Norms/standards

- CE: CE-compliant
- RoHS-compliance: compliant with RoHS 2
- TSE (transmissible spongiform encephalopathies): free from human and animal ingredients

6.2.7 Chemical resistance

- Alcohols: ethanol, benzene
- Chemical liquids: acids, cleaners, chemicals
- Cleaning agents: P3 (Topactive 200, 500, Okto, Topax 66)

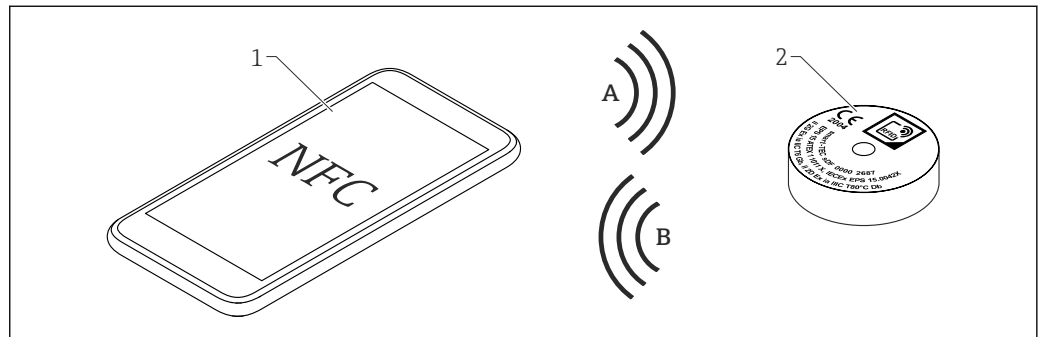
6.2.8 Labeling on NFC TAGs

A0026682

- A Data, energy
 B Data
 1 Mobile device that supports NFC
 2 NFC TAG

7 Maintenance

The metal TAG and the NFC TAG are maintenance-free.

When cleaning the NFC TAG, make sure that the cleaning agent used does not corrode the NFC TAG.

8 Accessories and Spare Parts

- i** ■ For ordering information, see → 6.
- If the device is difficult to access, the NFC TAG can also be mounted in another location where it is possible to identify which device the NFC TAG belongs to.
- Use the information printed on the TAG to verify that the TAG is assigned to the correct device. The serial number of the device must match the serial number printed on the packaging of the NFC TAG.

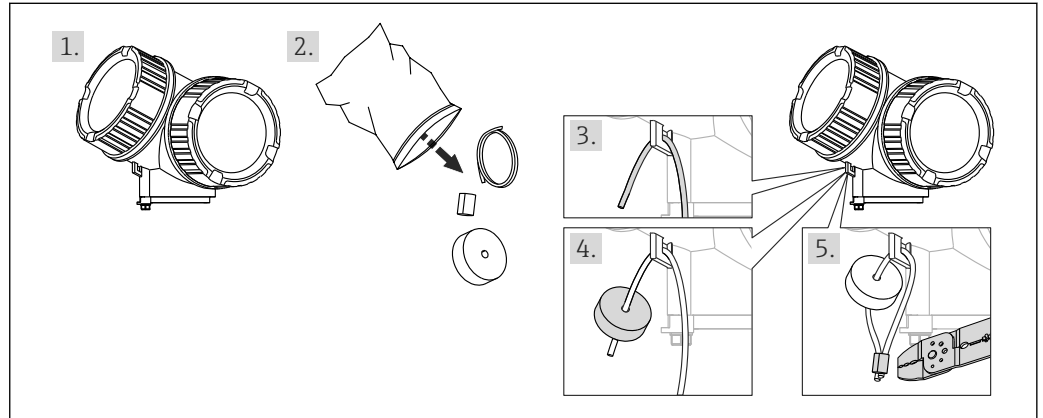

A0026584

1. Device without an NFC TAG.
2. NFC TAGs can be ordered at a later stage by specifying the serial number of the device. The specified data content is printed on the TAGs and they are supplied with fastening wire and a crimp sleeve.
3. To secure the TAG to the device, pull the wire through the eyelet on the device.
4. Pull the wire through the NFC TAG.
5. Place the crimp sleeve at the end of the wire and crimp using a standard crimping pliers.



www.addresses.endress.com
