

Operating Instructions

Cerabar PMP51B

Process pressure measurement
HART





A0023555

- Make sure the document is stored in a safe place such that it is always available when working on or with the device
- Avoid danger to individuals or the facility: read the "Basic safety instructions" section carefully, as well as all other safety instructions in the document that are specific to working procedures

The manufacturer reserves the right to modify technical data without prior notice. The Endress+Hauser sales organization will supply you with current information and updates to these instructions.

Table of contents

1	About this document	5	8	System integration	36
1.1	Document function	5	8.1	Overview of device description files	36
1.2	Symbols	5	8.2	Measured variables via HART protocol	36
1.3	List of abbreviations	7	9	Commissioning	38
1.4	Turn down calculation	7	9.1	Preliminaries	38
1.5	Documentation	8	9.2	Function check	38
1.6	Registered trademarks	8	9.3	Establishing a connection via FieldCare and DeviceCare	39
2	Basic safety instructions	9	9.4	Configuring the device address via software ..	39
2.1	Requirements for the personnel	9	9.5	Setting the operating language	40
2.2	Intended use	9	9.6	Configuring the device	40
2.3	Workplace safety	9	9.7	"Simulation" submenu	45
2.4	Operational safety	9	9.8	Protecting settings from unauthorized access	45
2.5	Product safety	10	10	Operation	47
2.6	Functional Safety SIL (optional)	10	10.1	Reading off the device locking status	47
2.7	IT security	10	10.2	Reading off measured values	47
2.8	Device-specific IT security	10	10.3	Adapting the device to process conditions	47
3	Product description	11	11	Diagnosis and troubleshooting	49
3.1	Product design	11	11.1	General troubleshooting	49
4	Incoming acceptance and product identification	14	11.2	Diagnostic information on local display	53
4.1	Incoming acceptance	14	11.3	Diagnostic event in the operating tool	54
4.2	Product identification	14	11.4	Adapting the diagnostic information	54
4.3	Storage and transport	15	11.5	Queued diagnostic messages	54
5	Mounting	16	11.6	Diagnostic list	54
5.1	Mounting requirements	16	11.7	Event logbook	57
5.2	Mounting the device	18	11.8	Device reset	59
5.3	Post-mounting check	25	11.9	Device information	60
6	Electrical connection	26	11.10	Firmware history	61
6.1	Connecting requirements	26	12	Maintenance	62
6.2	Connecting the device	26	12.1	Maintenance work	62
6.3	Ensuring the degree of protection	31	13	Repair	63
6.4	Post-connection check	31	13.1	General information	63
7	Operation options	32	13.2	Spare parts	63
7.1	Overview of operation options	32	13.3	Replacement	63
7.2	Operating keys and DIP switches on the electronic insert	32	13.4	Return	64
7.3	Structure and function of the operating menu	32	13.5	Disposal	64
7.4	Access to the operating menu via the local display	33	14	Accessories	65
7.5	Access to the operating menu via the operating tool	34	14.1	Device-specific accessories	65
			14.2	Device Viewer	65
			15	Technical data	66
			15.1	Output	66
			15.2	Environment	68
			15.3	Process	71

Index..... 78

1 About this document

1.1 Document function

These Operating Instructions contain all the information that is required in various phases of the life cycle of the device: from product identification, incoming acceptance and storage, to mounting, connection, operation and commissioning through to troubleshooting, maintenance and disposal.

1.2 Symbols

1.2.1 Safety symbols

 DANGER

This symbol alerts you to a dangerous situation. Failure to avoid this situation will result in serious or fatal injury.

 WARNING

This symbol alerts you to a dangerous situation. Failure to avoid this situation can result in serious or fatal injury.

 CAUTION

This symbol alerts you to a dangerous situation. Failure to avoid this situation can result in minor or medium injury.

NOTICE

This symbol contains information on procedures and other facts which do not result in personal injury.

1.2.2 Electrical symbols

Ground connection: 

Terminal for connection to the grounding system.

1.2.3 Symbols for certain types of information

Permitted: 

Procedures, processes or actions that are permitted.

Forbidden: 

Procedures, processes or actions that are forbidden.

Additional information: 

Reference to documentation: 

Reference to page: 

Series of steps: [1](#), [2](#), [3](#).

Result of an individual step: 



1.2.4 Symbols in graphics

Item numbers: 1, 2, 3 ...

Series of steps: [1](#), [2](#), [3](#).

Views: A, B, C, ...

1.2.5 Symbols on the device

Safety instructions:  → 

Observe the safety instructions contained in the associated Operating Instructions.

1.3 List of abbreviations

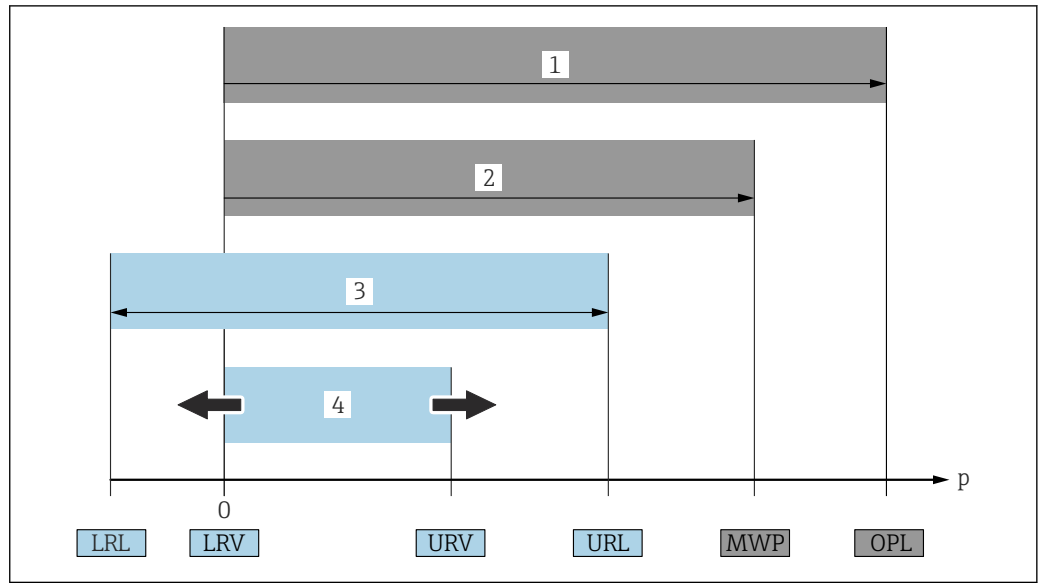

- 1 OPL: The OPL (overpressure limit = measuring cell overload limit) for the device depends on the lowest-rated element, with regard to pressure, of the selected components, i.e. the process connection has to be taken into consideration in addition to the measuring cell. Pay attention to the pressure/temperature dependency.
 - 2 The MWP (maximum working pressure) for the measuring cells depends on the lowest-rated element, with regard to pressure, of the selected components, i.e. the process connection has to be taken into consideration in addition to the measuring cell. Pay attention to the pressure/temperature dependency. The MWP may be applied at the device for an unlimited period of time. The MWP can be found on the nameplate.
 - 3 The maximum measuring range corresponds to the span between the LRL and URL. This measuring range is equivalent to the maximum calibratable/adjustable span.
 - 4 The calibrated/adjusted span corresponds to the span between the LRV and URV. Factory setting: 0 to URL. Other calibrated spans can be ordered as customized spans.
- p Pressure
 LRL Lower range limit
 URL Upper range limit
 LRV Lower range value
 URV Upper range value
 TD Turn down. Example - see the following section.

1.4 Turn down calculation

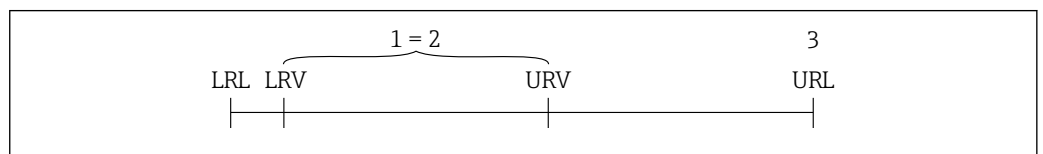

- 1 Calibrated/adjusted span
- 2 Zero point-based span
- 3 Upper range limit

Example:

- Measuring cell: 10 bar (150 psi)
- Upper range limit (URL) = 10 bar (150 psi)
- Calibrated/adjusted span: 0 to 5 bar (0 to 75 psi)
- Lower range value (LRV) = 0 bar (0 psi)
- Upper range value (URV) = 5 bar (75 psi)

$$TD = \frac{URL}{|URV - LRV|}$$

In this example, the TD is therefore 2:1. This measuring span is based on the zero point.

1.5 Documentation

All available documents can be downloaded using:

- the serial number of the device (see cover page for description) or
- the data matrix code of the device (see cover page for description) or
- the "Downloads" area of the website www.endress.com

1.5.1 Supplementary device-dependent documentation

Additional documents are supplied depending on the device version ordered: Always comply strictly with the instructions in the supplementary documentation. The supplementary documentation is an integral part of the device documentation.

1.6 Registered trademarks

HART®

Registered trademark of the FieldComm Group, Austin, Texas, USA

Bluetooth®

The Bluetooth® wordmark and logos are registered trademarks of Bluetooth SIG, Inc. and any use of these trademarks by Endress+Hauser is licensed. Other trademarks and trade names are those of their respective owners.

Apple®

Apple, the Apple logo, iPhone, and iPod touch are trademarks of Apple Inc., registered in the U.S. and other countries. App Store is a service mark of Apple Inc.

Android®

Android, Google Play and the Google Play logo are trademarks of Google Inc.

2 Basic safety instructions

2.1 Requirements for the personnel

The personnel for installation, commissioning, diagnostics and maintenance must fulfill the following requirements:

- ▶ Trained, qualified specialists must have a relevant qualification for this specific function and task
- ▶ Are authorized by the plant owner/operator
- ▶ Are familiar with federal/national regulations
- ▶ Before beginning work, the specialist staff must have read and understood the instructions in the Operating Instructions and supplementary documentation as well as in the certificates (depending on the application)
- ▶ Follow instructions and comply with conditions

The operating personnel must fulfill the following requirements:

- ▶ Being instructed and authorized according to the requirements of the task by the facility's owner-operator
- ▶ Following the instructions in these Operating Instructions

2.2 Intended use

The Cerabar is a pressure transmitter for measuring level and pressure.

2.2.1 Incorrect use

The manufacturer is not liable for damage caused by improper or non-intended use.

Verification for borderline cases:

- ▶ For special fluids and fluids for cleaning, Endress+Hauser is glad to provide assistance in verifying the corrosion resistance of fluid-wetted materials, but does not accept any warranty or liability.

2.3 Workplace safety

When working on and with the device:

- ▶ Wear the required personal protective equipment according to federal/national regulations.
- ▶ Switch off the supply voltage before connecting the device.

2.4 Operational safety

Risk of injury!

- ▶ Operate the device only if it is in proper technical condition, free from errors and faults.
- ▶ The operator is responsible for the interference-free operation of the device.

Modifications to the device

Unauthorized modifications to the device are not permitted and can lead to unforeseeable dangers:

- ▶ If, despite this, modifications are required, consult with Endress+Hauser.

Repair

To ensure continued operational safety and reliability:

- ▶ Carry out repairs on the device only if they are expressly permitted.
- ▶ Observe federal/national regulations pertaining to the repair of an electrical device.
- ▶ Use original spare parts and accessories from Endress+Hauser only.

Hazardous area

To eliminate the risk of danger to persons or the facility when the device is used in the approval-related area (e.g. explosion protection, pressure equipment safety):

- ▶ Check the nameplate to verify if the device ordered can be put to its intended use in the approval-related area.
- ▶ Observe the specifications in the separate supplementary documentation that is an integral part of these Instructions.

2.5 Product safety

This device is designed in accordance with good engineering practice to meet state-of-the-art safety requirements, has been tested, and left the factory in a condition in which it is safe to operate.

It meets general safety standards and legal requirements. It also complies with the EC directives listed in the device-specific EC Declaration of Conformity. Endress+Hauser confirms this by affixing the CE mark to the device.

2.6 Functional Safety SIL (optional)

The Functional Safety Manual must be strictly observed for devices that are used in functional safety applications.

2.7 IT security

Endress+Hauser can only provide a warranty if the device is installed and used as described in the Operating Instructions. The device is equipped with security mechanisms to protect it against any inadvertent changes to the device settings. IT security measures in line with operators' security standards and designed to provide additional protection for the device and device data transfer must be implemented by the operators themselves.

2.8 Device-specific IT security

The device offers specific functions to support protective measures by the operator. These functions can be configured by the user and guarantee greater in-operation safety if used correctly. An overview of the most important functions is provided in the following section:

- Write protection via hardware write protection switch
- Access code to change user role (applies to operation via Bluetooth, FieldCare, DeviceCare and asset management tools (e.g. AMS, PDM))

3 Product description

3.1 Product design

3.1.1 Metallic membrane

Standard device (without diaphragm seal)

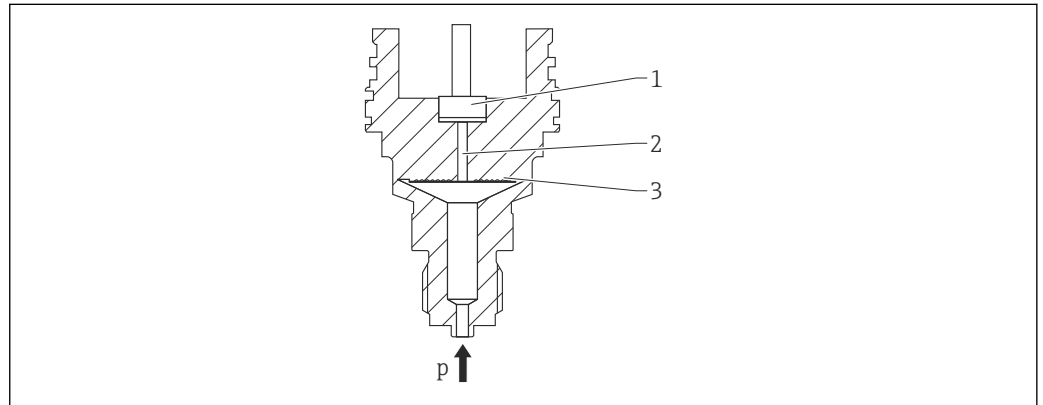

A0043089

- 1 Measuring element
- 2 Channel with fill fluid
- 3 Metallic membrane
- p Pressure

The pressure deflects the metallic membrane of the measuring cell. A fill fluid transfers the pressure to a Wheatstone bridge (semiconductor technology). The pressure-dependent change in the bridge output voltage is measured and evaluated.

Advantages:

- Can be used for high pressures
- High long-term stability
- High overload resistance
- Secondary containment for enhanced integrity
- Significantly reduced thermal effect e.g. compared to diaphragm seal systems with capillaries

Device with diaphragm seal

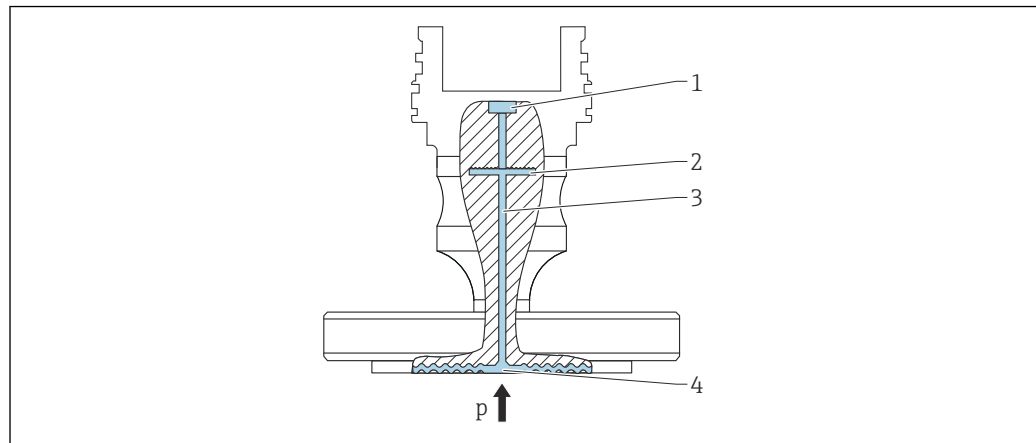

A0043583

- 1 Measuring element
- 2 Internal membrane
- 3 Channel with fill fluid
- 4 Metallic membrane
- p Pressure

The pressure acts on the membrane of the diaphragm seal and is transferred to the internal membrane by a fill fluid. The internal membrane is deflected. A fill fluid transfers the pressure to the measuring element on which a resistance bridge is located. The pressure-dependent change in the bridge output voltage is measured and evaluated.

Advantages:

- Depending on the version, can be used for pressures up to 400 bar (6 000 psi) and for extreme process temperatures
- High long-term stability
- High overload resistance
- Standard device (without diaphragm seal): secondary containment for enhanced integrity

Applications for diaphragm seals

Diaphragm seal systems are used if the process and the device need to be separated. Diaphragm seal systems offer clear advantages in the following instances:

- In the case of extreme process temperatures - through the use of temperature isolators or capillaries
- In the case of strong vibrations - decouple the process from the device by using a capillary
- In the case of aggressive or corrosive media - through the use of high-durability membrane materials
- In the case of media that crystallize or contain solids - through the choice of suitable coatings
- In the case of heterogeneous and fibrous process media
- If extreme measuring point cleaning is necessary, or in the event of very damp mounting locations
- For mounting locations that are difficult to access

3.1.2 Level measurement (level, volume and mass)

Standard device (without diaphragm seal)

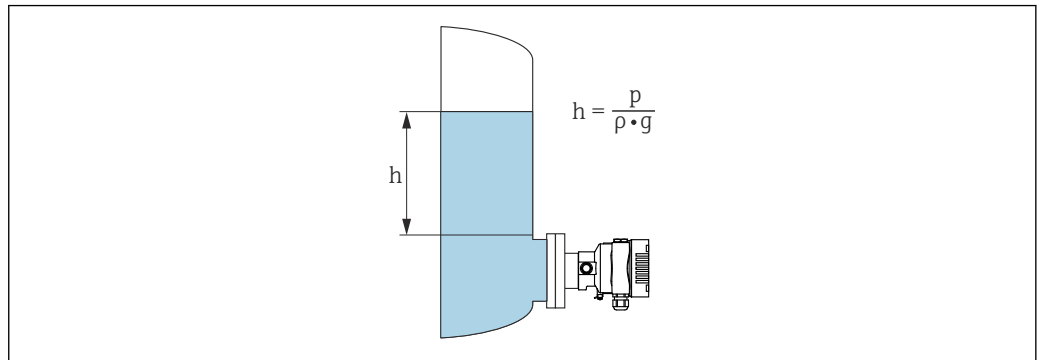

A0038343

h Height (level)
p Pressure
ρ Density of the medium
g Gravitational acceleration

Device with diaphragm seal

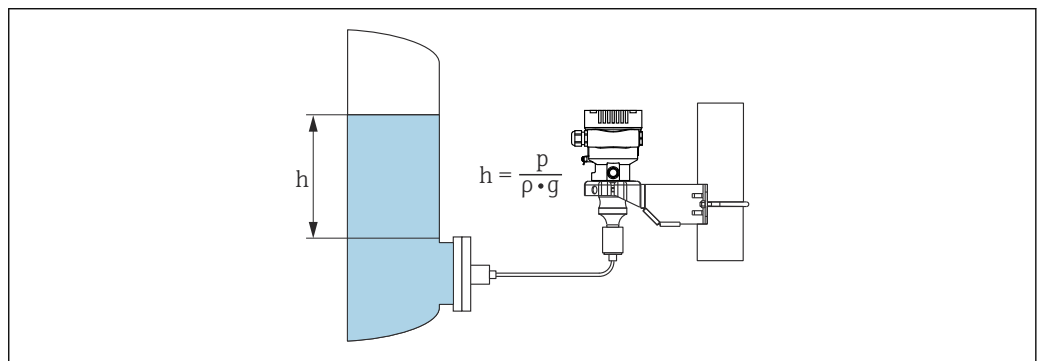

A0038342

1 Sample illustration: diaphragm seal with capillary

h Height (level)
p Pressure
ρ Density of the medium
g Gravitational acceleration

Advantages:

- Volume and mass measurements in any vessel shape with a freely programmable characteristic curve
- Has a wide range of uses, e.g.
 - For foam formation
 - In vessels with agitators or screen fittings
 - For liquid gases

4 Incoming acceptance and product identification

4.1 Incoming acceptance

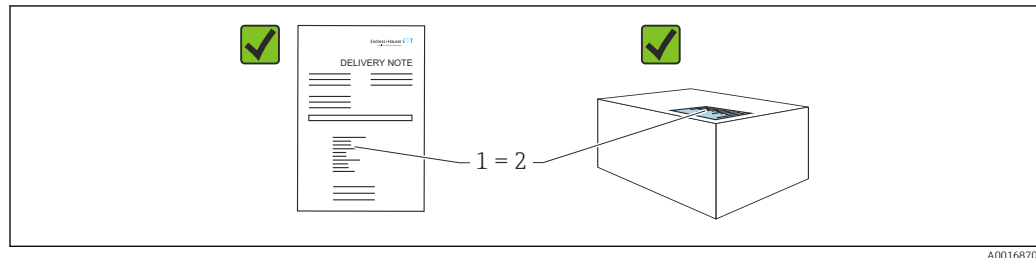

A0016870

- Is the order code on the delivery note (1) identical to the order code on the product sticker (2)?
- Are the goods undamaged?
- Do the data on the nameplate correspond to the order specifications and the delivery note?
- Is the documentation available?
- If required (see nameplate): are the Safety Instructions (XA) provided?

i If you can answer "no" to any of these questions, please contact Endress+Hauser.

4.1.1 Scope of delivery

The scope of delivery comprises:

- Device
- Optional accessories

Accompanying documentation:

- Brief Operating Instructions
- Final inspection report
- Additional Safety Instructions for devices with approvals (e.g. ATEX, IECEx, NEPSI, etc.)
- Optional: factory calibration form, test certificates

i The Operating Instructions are available on the Internet at:

www.endress.com → Download

4.2 Product identification

The following options are available for identification of the device:

- Nameplate specifications
- Order code with breakdown of the device features on the delivery note
- Enter the serial numbers from the nameplates in *Device Viewer* (www.endress.com/deviceviewer): all the information about the device is displayed.

4.2.1 Manufacturer address

Endress+Hauser SE+Co. KG
 Hauptstraße 1
 79689 Maulburg, Germany
 Place of manufacture: See nameplate.

4.2.2 Nameplate

Different nameplates are used depending on the device version.

The nameplates contain the following information:

- Manufacturer name and device name
- Address of the certificate holder and country of manufacture
- Order code and serial number
- Technical data
- Approval-specific information

Compare the data on the nameplate with your order.

4.3 Storage and transport

4.3.1 Storage conditions

- Use the original packaging
- Store the device in clean and dry conditions and protect from damage caused by shocks

Storage temperature range

See Technical Information.

4.3.2 Transporting the product to the measuring point

WARNING

Incorrect transport!

Housing and membrane may become damaged, and there is a risk of injury!

- ▶ Transport the device to the measuring point in the original packaging.

WARNING

Incorrect transport!

Capillaries may become damaged, and there is a risk of injury!

- ▶ Do not use capillaries as a carrying aid for the diaphragm seals.

5 Mounting

5.1 Mounting requirements

5.1.1 General instructions

- Do not clean or touch the membrane with hard and/or pointed objects.
- Do not remove the protection on the membrane until just before installation.

Always firmly tighten the housing cover and the cable entries.

1. Counter-tighten the cable entries.
2. Tighten the coupling nut.

5.1.2 Installation instructions

- The standard devices (without diaphragm seals) are mounted according to the same guidelines as pressure gauges (DIN EN837-2)
- To ensure optimal readability of the local display, adjust the housing and local display
- Endress+Hauser offers a mounting bracket to mount the device on pipes or walls
- Use flushing rings for flanges, flange seals and pancake seals if buildup or clogging can be expected at the membrane
 - The flushing ring is clamped between the process connection and the flange, flange seal or pancake seal
 - Material buildup in front of the membrane is flushed away, and the pressure chamber is vented, via the two lateral flushing holes
- When measuring in media containing solids (e.g. dirty liquids), installing separators and drain valves is useful for capturing and removing sediment
- Using a valve manifold allows for easy commissioning, installation and maintenance without interrupting the process
- When mounting the device, establishing the electrical connection and during operation: prevent the penetration of moisture into the housing
- Point the cable and plug downwards as much as possible to prevent moisture from entering (e.g. rainwater or condensation)

5.1.3 Installation instructions for thread

- Device with G 1 ½" thread:
 - Place the flat seal on the sealing surface of the process connection
 - Avoid additional strain on the membrane: do not seal the thread with hemp or similar materials
- Device with NPT thread:
 - Wrap Teflon tape around the thread to seal it
 - Tighten the device at the hexagon bolt only; do not turn it by the housing
 - When screwing in, do not overtighten the thread; tighten the NPT thread to the required depth according to the standard
- For the following process connections, a tightening torque of max. 40 Nm (29.50 lbf ft) is specified:
 - Thread ISO228 G ½" with flush membrane
 - Thread DIN13 M20 x 1.5 with flush membrane
 - NPT ¾" with flush membrane

5.1.4 Installation instructions for devices with diaphragm seals

NOTICE

Improper handling!

Damage to the device!

- ▶ The diaphragm seal and pressure transmitter form a closed, calibrated system which has been filled with diaphragm seal fill fluid. Never open any of the holes for fill fluid.
- ▶ Ensure strain relief to prevent the capillary from bending (bending radius \geq 100 mm (3.94 in)).
- ▶ Do not use capillaries as a carrying aid for the diaphragm seals.
- ▶ Observe the application limits of the fill fluid.

General information

In the case of devices with diaphragm seals and capillaries, the zero point shift caused by the hydrostatic pressure of the filling liquid column in the capillaries must be taken into account when selecting the measuring cell. If a measuring cell with a small measuring range is selected, a position adjustment can cause the measuring cell to go over range (position adjustment due to zero point offset, caused by the orientation of the fill fluid liquid column). Perform zero adjustment if necessary.

For devices with a capillary, use a suitable bracket (mounting bracket) for mounting.

When mounting, sufficient strain relief must be provided for the capillary to prevent the capillary from bending (capillary bending radius \geq 100 mm (3.94 in)).

Mount the capillary so that it is vibration-free (in order to avoid additional pressure fluctuations).

Do not mount capillaries in the vicinity of heating or cooling lines and protect them against direct sunlight.

More detailed installation instructions are provided in the Applicator "[Sizing Diaphragm Seal](#)".

5.1.5 Orientation

NOTICE

Damage to the device!

If a heated device is cooled during a cleaning process (e.g. by cold water), a vacuum develops for a short time. As a result of this, moisture can enter the measuring cell via the pressure compensation element (1).

- ▶ Mount the device as follows.

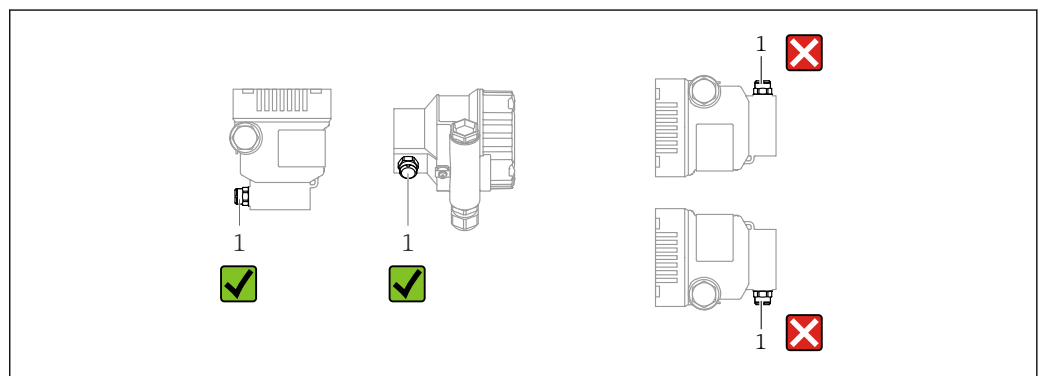

A0038723

- Keep the pressure compensation element (1) free from contamination
- A position-dependent zero point shift (when the vessel is empty the measured value does not display zero) can be corrected
- Diaphragm seals also shift the zero point, depending on the installation position
- The use of shutoff devices and/or water pocket pipes is recommended for mounting
- The orientation depends on the measuring application

5.2 Mounting the device

5.2.1 Pressure measurement in gases

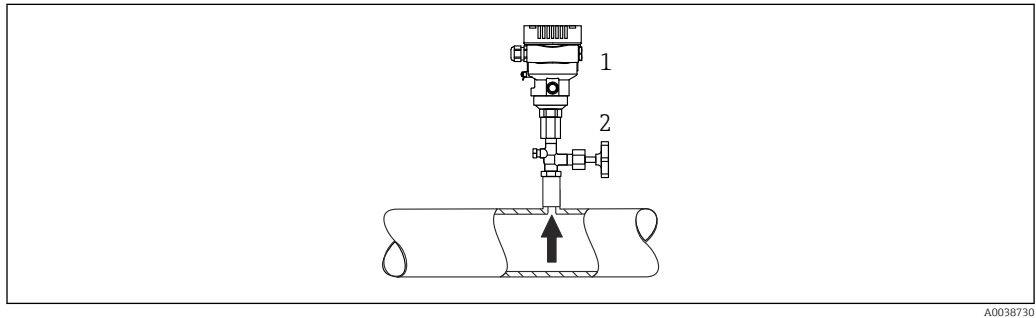

A0038730

- 1 Device
- 2 Shutoff device

Mount the device with the shutoff device above the tapping point so that any condensate can flow into the process.

5.2.2 Pressure measurement in steam

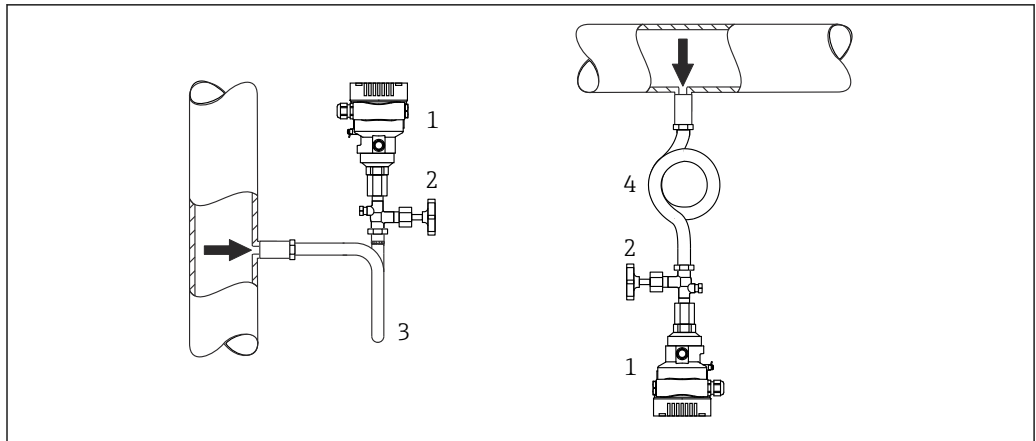

A0038731

- 1 Device
- 2 Shutoff device
- 3 U-shaped siphon
- 4 O-shaped siphon

Observe the maximum permitted ambient temperature of the transmitter!

Mounting:

- Ideally, mount the device with the O-shaped siphon below the tapping point
The device may also be mounted above the tapping point
- Fill the siphon with liquid before commissioning

Advantages of using siphons:

- Protects the measuring device from hot, pressurized media due to the formation and collection of condensate
- Attenuation of water hammer
- The defined water column only causes minimal (negligible) measured errors and minimal (negligible) thermal effects on the device

 For technical data (e.g. materials, dimensions or order numbers), see the accessory document SD01553P.

5.2.3 Pressure measurement in liquids

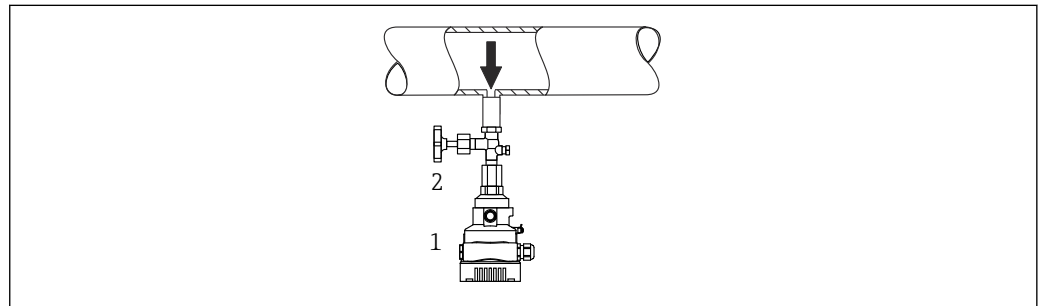

- 1 Device
2 Shutoff device

Mount the device with the shutoff device below or at the same level as the tapping point.

5.2.4 Level measurement

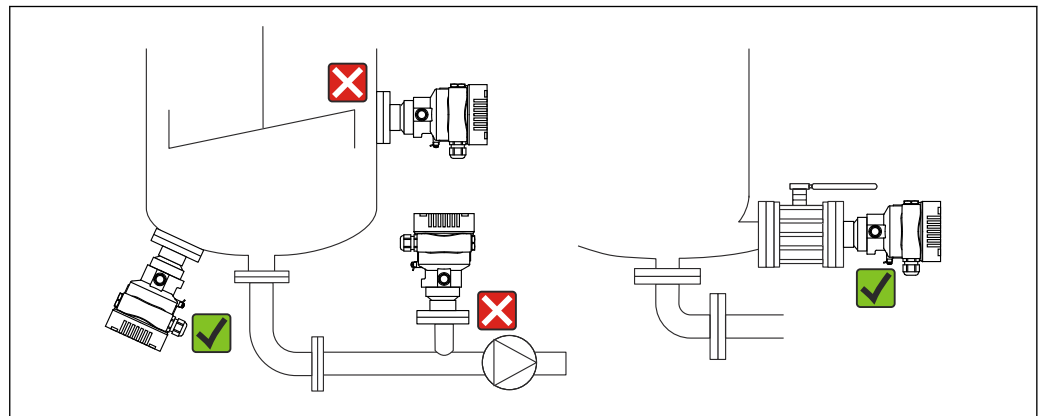

- Always mount the device below the lowest measuring point
- Do not install the device at the following positions:
 - In the filling curtain
 - In the tank outlet
 - In the suction area of a pump
 - At a point in the tank which could be affected by pressure pulses from the agitator
- Mount the device downstream from a shutoff device: the calibration and function check can be carried out more easily

5.2.5 Thermal insulation with diaphragm seal directly mounted

The device may only be insulated up to a certain height. The maximum permitted insulation height is indicated on the device and applies to an insulation material with a heat conductivity $\leq 0.04 \text{ W}/(\text{m} \times \text{K})$ and to the maximum permitted ambient and process

temperature. The data were determined under the most critical application "quiescent air". Maximum permitted insulation height, indicated here on a device with a flange:

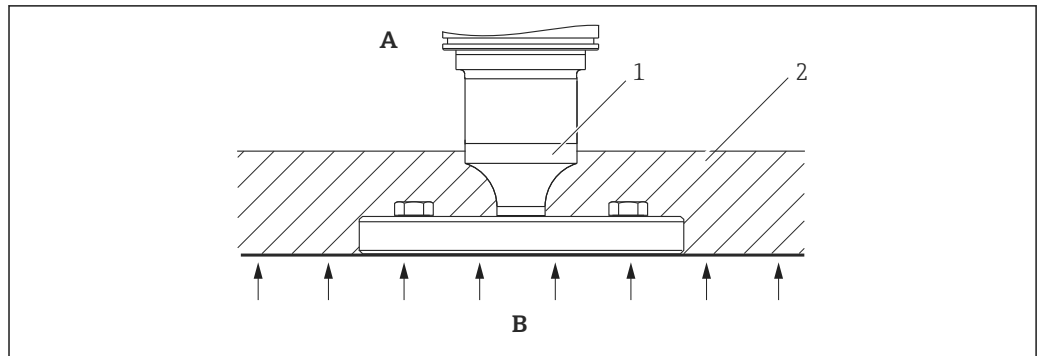

A0020474

- A Ambient temperature
- B Process temperature
- 1 Maximum permitted insulation height
- 2 Insulation material

5.2.6 Mounting with a "Compact" diaphragm seal type

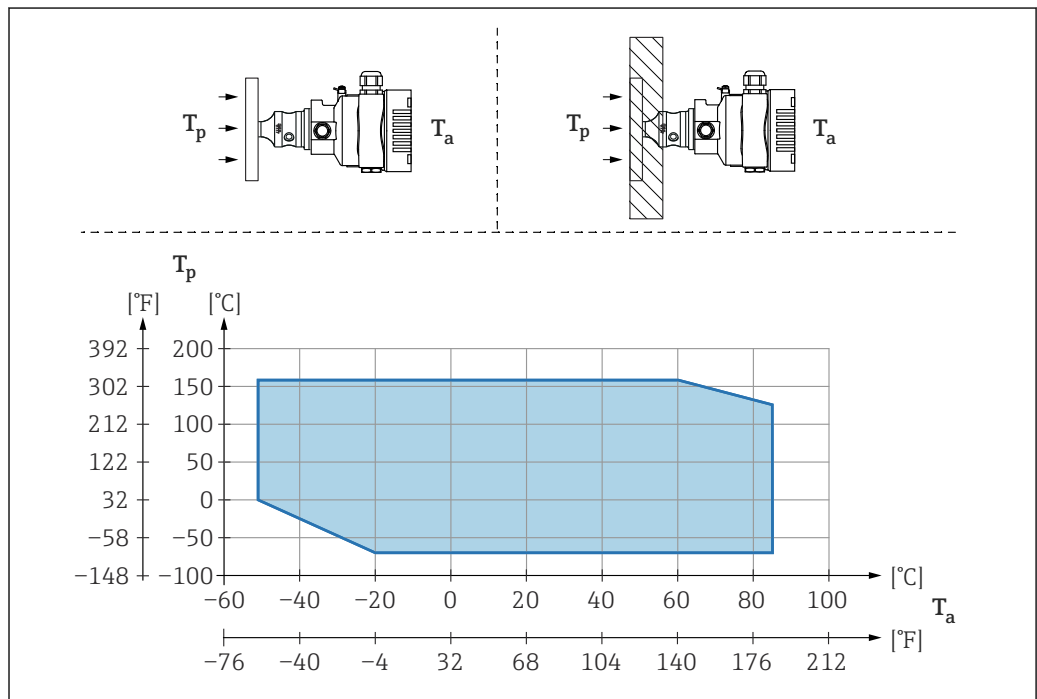

A0040383

- T_a Ambient temperature at transmitter
- T_p Maximum process temperature

T_a	T_p
+85 °C (+185 °F)	-70 to +120 °C (-94 to +248 °F)
+60 °C (+140 °F)	-70 to +160 °C (-94 to +320 °F)
-20 °C (-4 °F)	-70 to +160 °C (-94 to +320 °F)
-50 °C (-58 °F)	0 to +160 °C (+32 to +320 °F)

5.2.7 Thermal insulation when mounting with a "Temperature isolator" diaphragm seal type

Use of temperature isolators in the event of constant extreme medium temperatures which cause the maximum permissible electronics temperature of +85 °C (+185 °F) to be exceeded. Diaphragm seal systems with temperature isolators can be used up to a maximum temperature of +400 °C (+752 °F) depending on the fill fluid used. For details, see the Technical Information. To minimize the influence of rising heat, mount the device horizontally or with the housing pointing downwards. The additional installation height brings about a zero point shift due to the hydrostatic column in the temperature isolator. This zero point shift can be corrected on the device.

The maximum ambient temperature T_a at the transmitter depends on the maximum process temperature T_p .

The maximum process temperature depends on the fill fluid used.

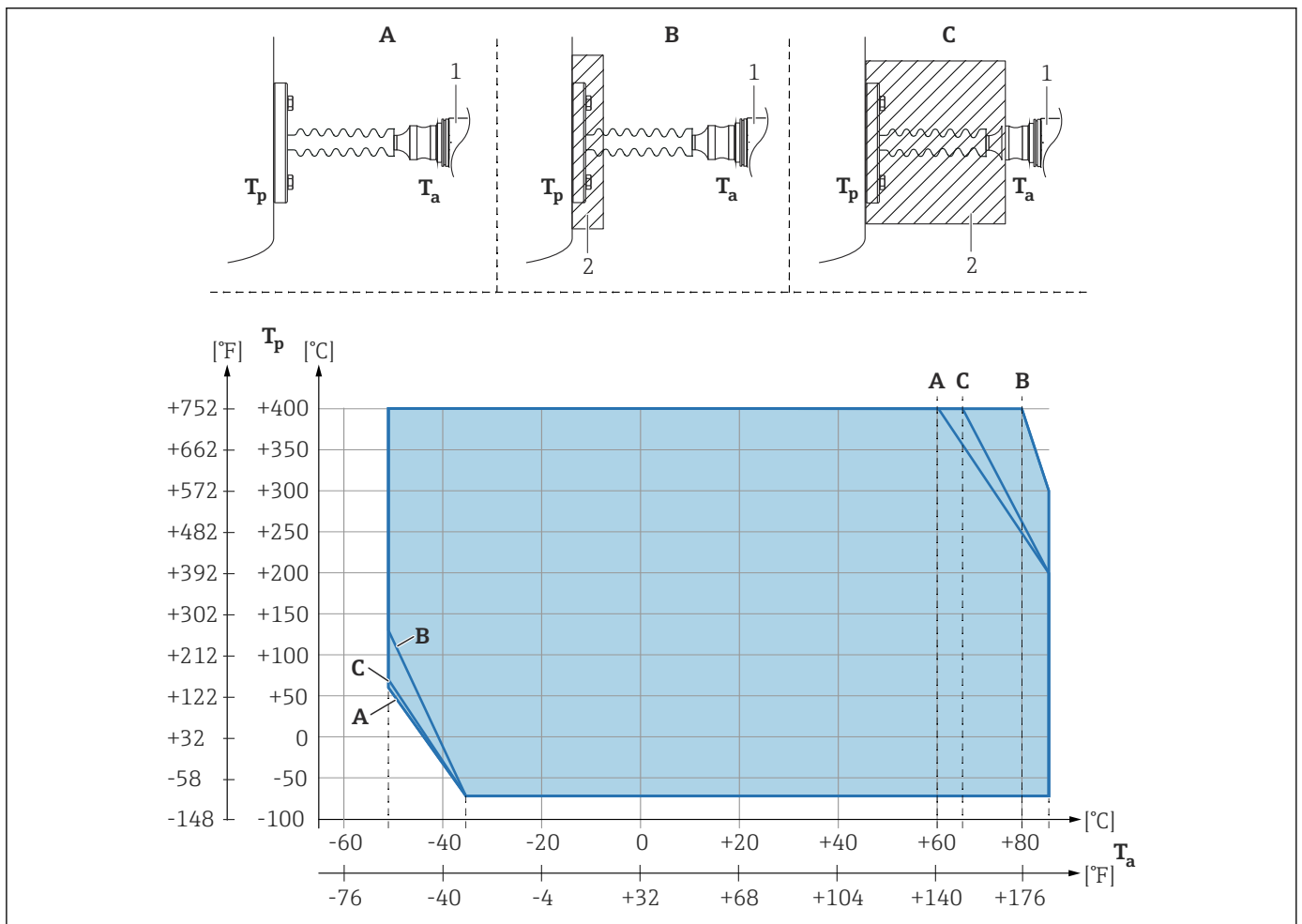

- A No insulation
- B Insulation 30 mm (1.18 in)
- C Maximum insulation
- 1 Transmitter
- 2 Insulation material

Item	T_a ¹⁾	T_p ²⁾
A	60 °C (140 °F)	400 °C (752 °F) ³⁾
	85 °C (185 °F)	200 °C (392 °F)
	-50 °C (-58 °F)	60 °C (140 °F)

Item	T _a ¹⁾	T _p ²⁾
	-35 °C (-31 °F)	-70 °C (-94 °F)
B	80 °C (176 °F)	400 °C (752 °F) ³⁾
	85 °C (185 °F)	300 °C (572 °F)
	-50 °C (-58 °F)	130 °C (266 °F)
	-35 °C (-31 °F)	-70 °C (-94 °F)
C	67 °C (153 °F)	400 °C (752 °F) ³⁾
	85 °C (185 °F)	200 °C (392 °F)
	-50 °C (-58 °F)	70 °C (158 °F)
	-35 °C (-31 °F)	-70 °C (-94 °F)

- 1) Maximum ambient temperature at transmitter
- 2) Maximum process temperature
- 3) Process temperature: max. +400 °C (+752 °F), depending on the fill fluid used

5.2.8 Oxygen applications (gaseous)

Oxygen and other gases can react explosively to oils, grease and plastics. The following precautions must be taken:

- All components of the system, such as devices, must be cleaned in accordance with national requirements.
- Depending on the materials used, a certain maximum temperature and a maximum pressure must not be exceeded for oxygen applications.

The cleaning of the device (not accessories) is provided as an optional service.

- p_{max}: Depends on the lowest-rated element, with regard to pressure, of the selected components: Over pressure limit (OPL) of the measuring cell, process connection (1.5 x PN) or fill fluid (80 bar (1 200 psi))
- T_{max}: 60 °C (140 °F)

5.2.9 Seal for flange mounting

NOTICE

Seal pressing against the membrane!

Incorrect measurement results!

- ▶ Ensure that the seal is not touching the membrane.

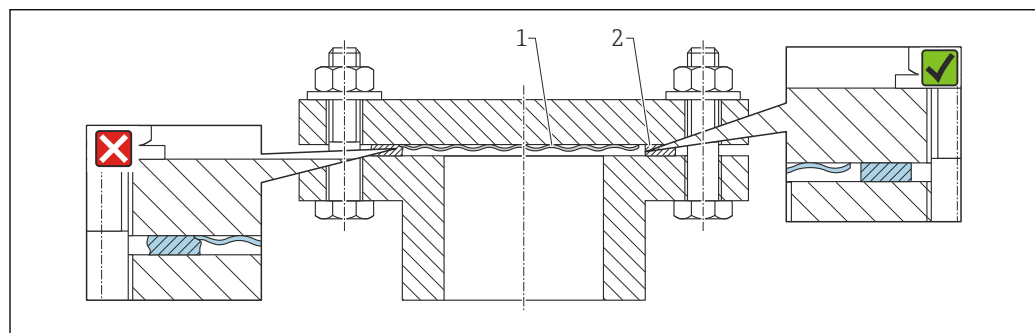

- 1 Membrane
- 2 Seal

A0017743

5.2.10 Mounting bracket for device or separate housing

The device or the separate housing can be mounted on walls or pipes (for pipes with a diameter of 1 1/4" to 2") using the mounting bracket.

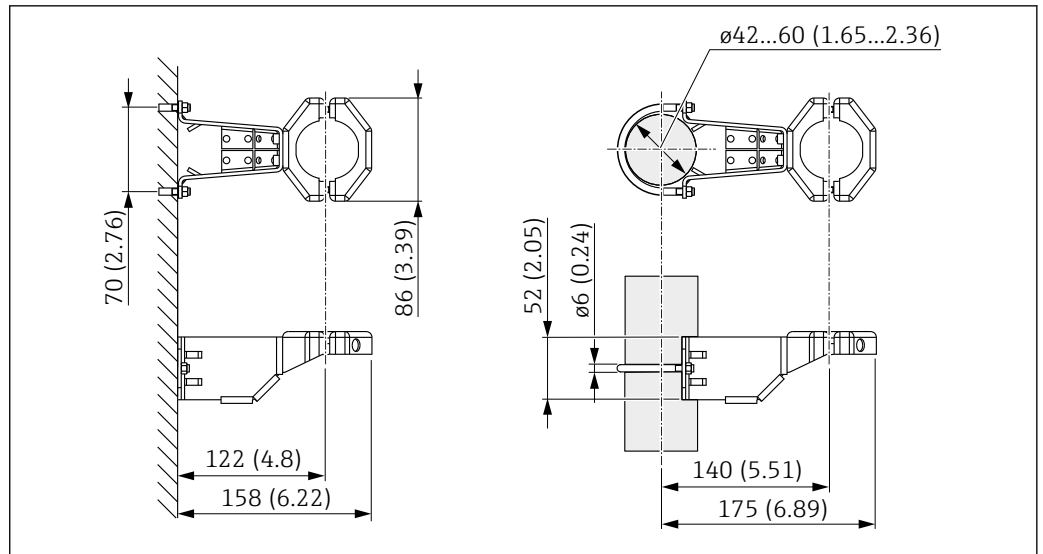

A0028493

Unit of measurement mm (in)

Ordering information:

- Can be ordered via the Product Configurator
- Can be ordered as a separate accessory, part number 71102216

i The mounting bracket is included in the delivery if you order the device with a separate housing.

When mounting on a pipe, tighten the nuts on the bracket uniformly with a torque of at least 5 Nm (3.69 lbf ft).

5.2.11 Assembling and mounting the separate housing

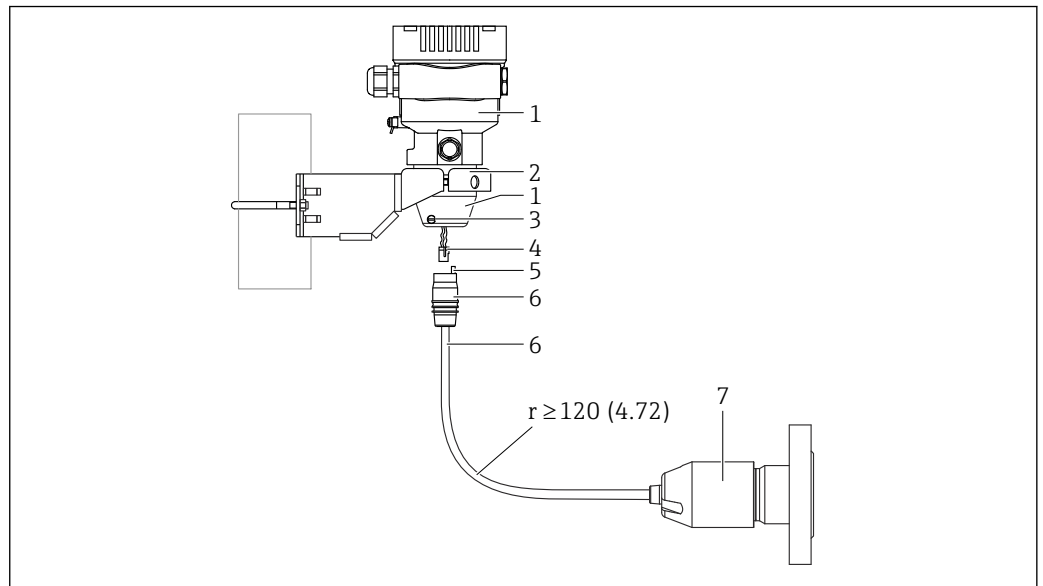

A0038728

Unit of measurement mm (in)

- 1 Housing mounted with housing adapter, included
- 2 Mounting bracket provided, suitable for pipe and wall mounting (for pipe diameters from 1 ¼" to 2")
- 3 Locking screw
- 4 Plug
- 5 Pressure compensation
- 6 Cable with connection jack
- 7 In the separate housing version, the measuring cell is delivered with the process connection and cable already mounted.

Assembly and mounting

1. Insert the connector (item 4) into the corresponding connection jack of the cable (item 6).
2. Insert the cable with the socket (item 6) into the housing adapter (item 1) to the end stop.
3. Tighten the locking screw (item 3).
4. Mount the housing on a wall or pipe with the mounting bracket (item 2). When mounting on a pipe, tighten the nuts on the bracket uniformly with a torque of at least 5 Nm (3.69 lbf ft). Mount the cable with a bending radius (r) \geq 120 mm (4.72 in).

5.2.12 Turning the display module

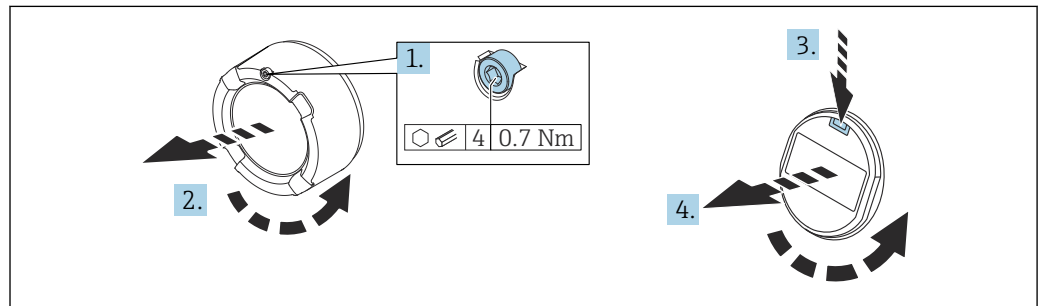

A0038224

⚠ WARNING

Supply voltage switched on!

Risk of electric shock and/or explosion!

- ▶ Switch off the supply voltage before opening the device.

⚠ CAUTION

Dual-compartment housing: When opening the terminal compartment cover, fingers can get trapped between the cover and the pressure compensation filter.

- ▶ Open the cover slowly.

1. If fitted: release the screw of the cover lock for the electronics compartment cover using the Allen key.
2. Unscrew the electronics compartment cover from the transmitter housing and check the cover seal.
3. Press the release mechanism and remove the display module.
4. Turn the display module to the desired position: maximum $4 \times 90^\circ$ in each direction. Fit the display module on the electronics compartment in the desired position until it clicks into place. Screw the electronics compartment cover back onto the transmitter housing. If provided: tighten the screw of the cover lock using the Allen key 0.7 Nm (0.52 lbf ft) \pm 0.2 Nm (0.15 lbf ft).

5.2.13 Closing the housing covers

NOTICE

Thread and housing cover damaged from dirt and fouling!

- ▶ Remove dirt (e.g. sand.) on the thread of the cover and housing.
- ▶ If you continue to encounter resistance when closing the cover, check the thread again for fouling.

i Housing thread

The threads of the electronics and connection compartment can be coated with an anti-friction coating.

The following applies for all housing materials:

- ✘ **Do not lubricate the housing threads.**

5.2.14 Turning the housing

The housing can be rotated up to 380° by loosening the locking screw.

Your benefits

- Easy mounting due to optimum alignment of housing
- Easily accessible device operation
- Optimum readability of the onsite display (optional)

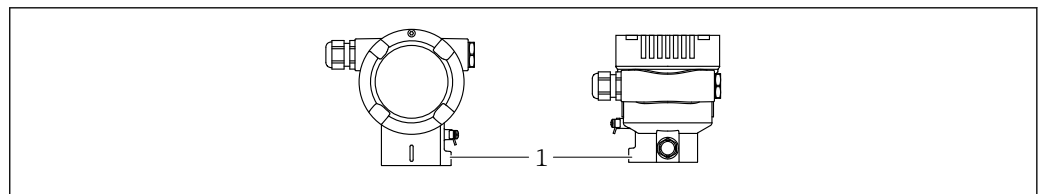

A0043807

1 Locking screw

NOTICE

The housing cannot be unscrewed fully.

- ▶ Loosen the external locking screw by a maximum of 1.5 turns. If the screw is unscrewed too much or completely (beyond the screw anchor point), small parts (counter disk) can become loose and fall out.
- ▶ Tighten the securing screw (hex socket 4 mm (0.16 in)) with maximum 3.5 Nm (2.58 lbf ft) ± 0.3 Nm (0.22 lbf ft).

5.3 Post-mounting check

- Is the device undamaged (visual inspection)?
- Are the measuring point identification and labeling correct (visual inspection)?
- Is the device protected against precipitation and direct sunlight?
- Are the securing screws and cover lock tightened securely?
- Does the measuring device meet the measuring point specifications?

For example:

- Process temperature
- Process pressure
- Ambient temperature
- Measuring range

6 Electrical connection

6.1 Connecting requirements

6.1.1 Potential equalization

The protective ground on the device must not be connected. If necessary, the potential matching line can be connected to the outer ground terminal of the device before the device is connected.

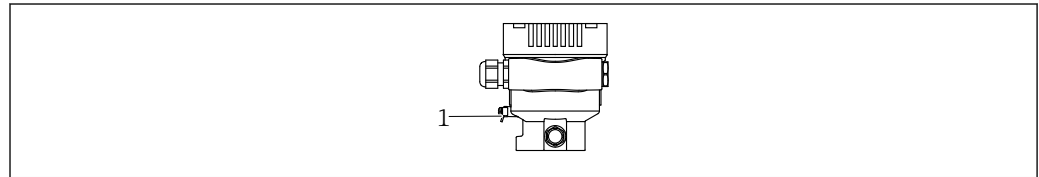

A0045411

1 Ground terminal for connecting the potential matching line

⚠ WARNING

Explosion Hazard!

► Please refer to the separate documentation on applications in hazardous areas for the safety instructions.



For optimum electromagnetic compatibility:

- Keep the potential matching line as short as possible
- Maintain a cross-section of at least 2.5 mm² (14 AWG)

6.2 Connecting the device

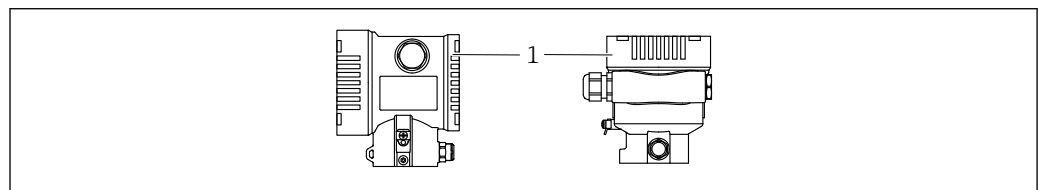

A0043806

1 Connection compartment cover



Housing thread

The threads of the electronics and connection compartment can be coated with an anti-friction coating.

The following applies for all housing materials:

⊗ Do not lubricate the housing threads.

6.2.1 Supply voltage

- Ex d, Ex e, non-Ex: supply voltage: 10.5 to 35 V_{DC}
- Ex i: supply voltage: 10.5 to 30 V_{DC}
- Nominal current: 4 to 20 mA HART



The power unit must be safety-approved (e.g. PELV, SELV, Class 2) and must comply with the relevant protocol specifications. For 4 to 20 mA, the same requirements apply as for HART.

6.2.2 Terminals

- Supply voltage and internal ground terminal: 0.5 to 2.5 mm² (20 to 14 AWG)
- External ground terminal: 0.5 to 4 mm² (20 to 12 AWG)

6.2.3 Cable specification

- Protective ground or grounding of the cable shield: rated cross-section > 1 mm² (17 AWG)
Rated cross-section of 0.5 mm² (20 AWG) to 2.5 mm² (13 AWG)
- Cable outer diameter: Ø5 to 12 mm (0.2 to 0.47 in) depends on the cable gland used (see Technical Information)

6.2.4 4-20 mA HART

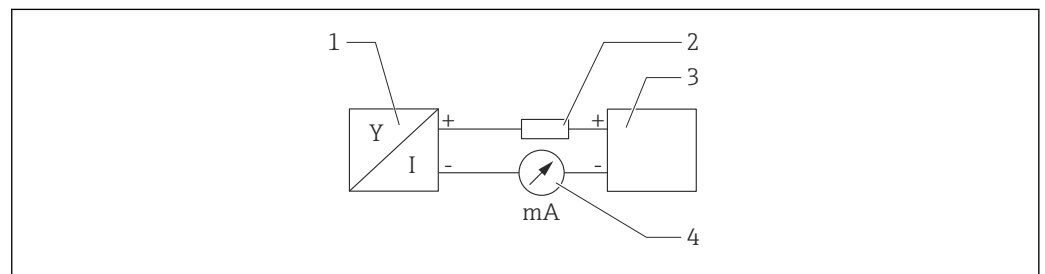

2 Block diagram of HART connection

- 1 Device with HART communication
- 2 HART communication resistor
- 3 Power supply
- 4 multimeter

i The HART communication resistor of 250 Ω in the signal line is always necessary in the case of a low-impedance power supply.

Take the voltage drop into consideration:

Maximum 6 V for a communication resistor of 250 Ω

6.2.5 Overvoltage protection

Devices without optional overvoltage protection

Equipment from Endress+Hauser fulfills the requirements of the product standard IEC / DIN EN 61326-1 (Table 2 Industrial Environment).

Depending on the type of port (DC power supply, input/output port) different testing levels according to IEC / DIN EN 61326-1 against transient overvoltages (Surge) are applied (IEC / DIN EN 61000-4-5 Surge):

Test level on DC power ports and input / output ports is 1000 V line to earth

Overvoltage category

Overvoltage category II

6.2.6 Wiring

⚠ WARNING

Supply voltage might be connected!

Risk of electric shock and/or explosion!

- ▶ If the device is used in hazardous areas, comply with national standards and the specifications in the Safety Instructions (XAs). Use the specified cable gland.
- ▶ The supply voltage must match the specifications on the nameplate.
- ▶ Switch off the supply voltage before connecting the device.
- ▶ If necessary, the potential matching line can be connected to the outer ground terminal of the transmitter before the device is connected.
- ▶ A suitable circuit breaker should be provided for the device in accordance with IEC/EN 61010.
- ▶ The cables must be adequately insulated, with due consideration given to the supply voltage and the overvoltage category.
- ▶ The connecting cables must offer adequate temperature stability, with due consideration given to the ambient temperature.
- ▶ Only operate the device with the covers closed.
- ▶ Protective circuits against reverse polarity, HF influences and overvoltage peaks are integrated.

Connect the device in the following order:

1. Release the cover lock (if provided).
2. Unscrew the cover.
3. Guide the cables into the cable glands or cable entries.
4. Connect the cables.
5. Tighten the cable glands or cable entries so that they are leak-tight. Counter-tighten the housing entry. Use a suitable tool with width across flats AF24/25 8 Nm (5.9 lbf ft) for the M20 cable gland.
6. Screw the cover securely back onto the connection compartment.
7. If fitted: tighten the screw of the cover lock using the Allen key 0.7 Nm (0.52 lbf ft) ± 0.2 Nm (0.15 lbf ft).

6.2.7 Terminal assignment

Single compartment housing

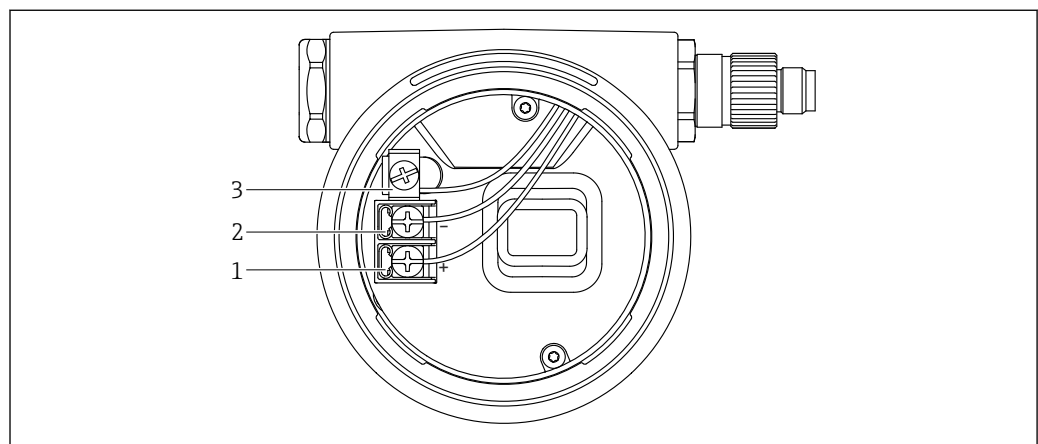

3 Connection terminals and ground terminal in the connection compartment

- 1 Positive terminal
- 2 Negative terminal
- 3 Internal ground terminal

Dual compartment housing

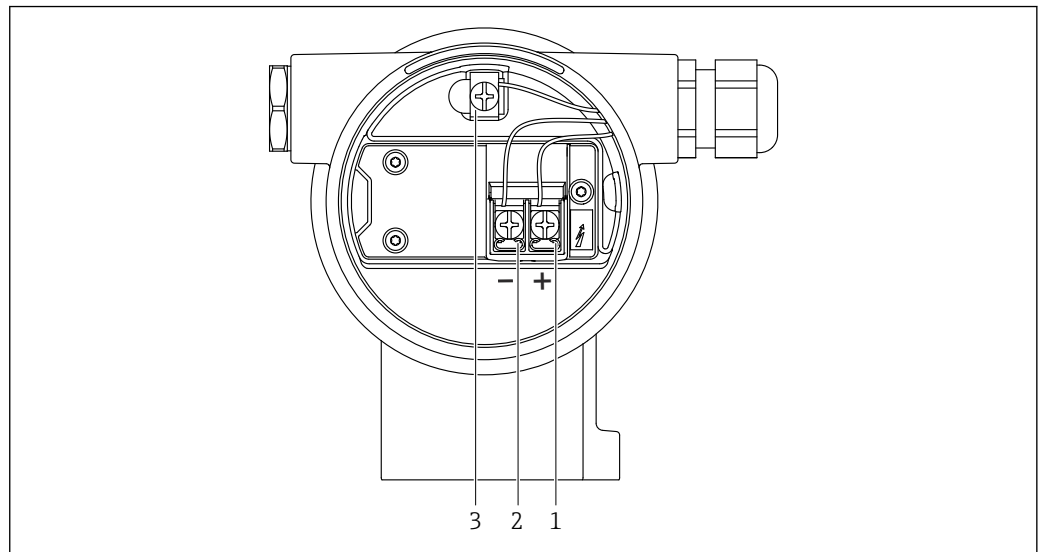

A0042803

4 Connection terminals and ground terminal in the connection compartment

- 1 Positive terminal
- 2 Negative terminal
- 3 Internal ground terminal

6.2.8 Cable entries

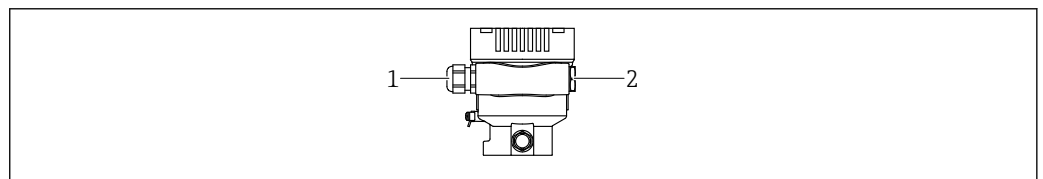

A0045413

- 1 Cable entry
- 2 Dummy plug

The type of cable entry depends on the device version ordered.

-  Always route connecting cables downwards so that moisture cannot penetrate the connection compartment.

If necessary, create a drip loop or use a weather protection cover.

6.2.9 Available device plugs

-  In the case of devices with a plug, it is not necessary to open the housing for connection purposes.

Use the enclosed seals to prevent the penetration of moisture into the device.

Devices with valve plug

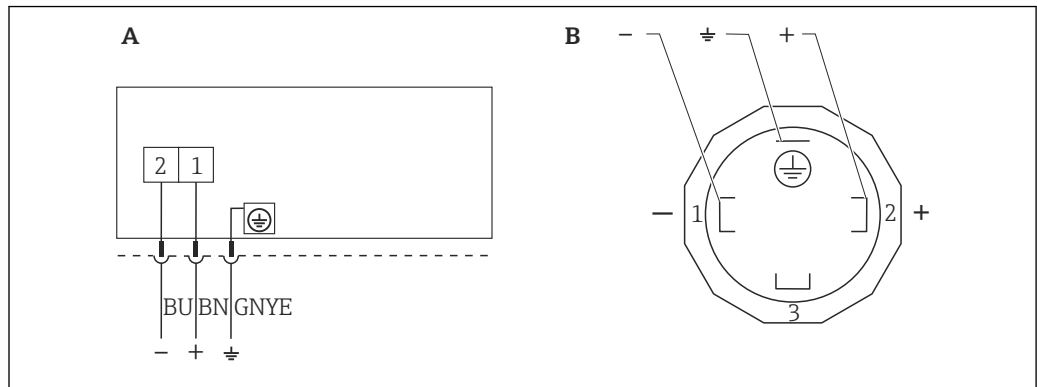

A0023097

5 BN = brown, BU = blue, GNYE = green/yellow

- A Electrical connection for devices with valve connector
- B View of the plug-in connection on the device

Devices with M12 plug

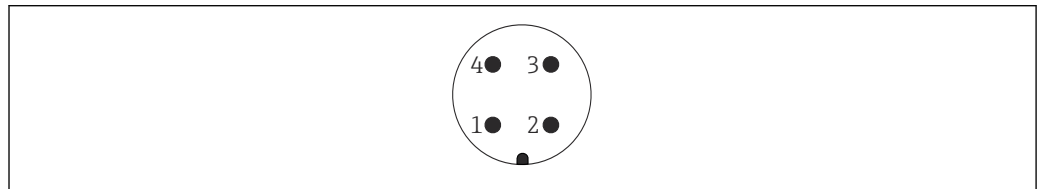

A0011175

- 1 Signal +
- 2 Not assigned
- 3 Signal -
- 4 Ground

Devices with a Harting plug Han7D

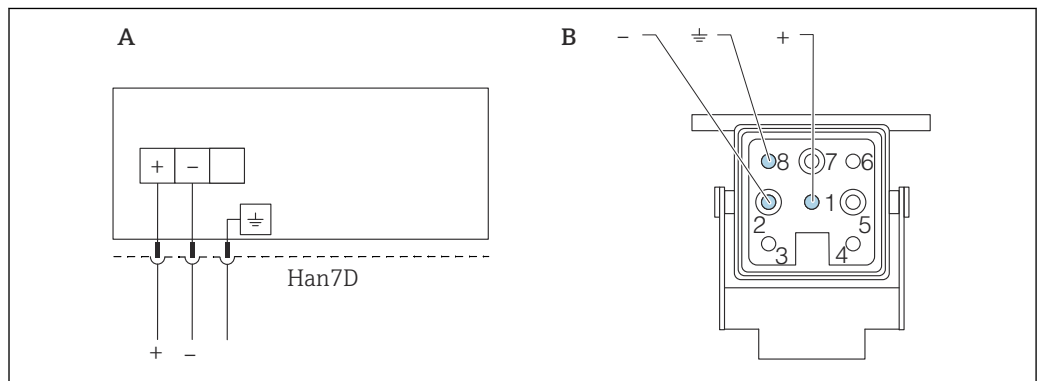

A0041011

- A Electrical connection for devices with Harting plug Han7D
- B View of the plug-in connection on the device
- Brown
- ≡ Green/yellow
- + Blue

6.3 Ensuring the degree of protection

6.3.1 Cable entries

- Gland M20, plastic, IP66/68 TYPE 4X/6P
 - Gland M20, brass nickel plated, IP66/68 TYPE 4X/6P
 - Gland M20, 316L, IP66/68 TYPE 4X/6P
 - Thread M20, IP66/68 TYPE 4X/6P
 - Thread G1/2, IP66/68 TYPE 4X/6P
- If the G1/2 thread is selected, the device is delivered with an M20 thread as standard and a G1/2 adapter is included with the delivery, along with the corresponding documentation
- Thread NPT1/2, IP66/68 TYPE 4X/6P
 - Dummy plug transport protection: IP22, TYPE 2
 - *Cable 5 m, IP66/68 TYPE 4X/6P pressure compensation via cable
 - *Valve plug ISO4400 M16, IP65 TYPE 4X
 - HAN7D plug, 90 degrees, IP65 NEMA Type 4X
 - M12 plug
- When housing is closed and connecting cable is plugged in: IP66/67, NEMA Type 4X
When housing is open or connecting cable is not plugged in: IP20, NEMA Type 1

NOTICE

M12 plug and HAN7D plug: incorrect mounting can invalidate the IP protection class!

- ▶ The degree of protection only applies if the connecting cable used is plugged in and screwed tight.
- ▶ The degree of protection only applies if the connecting cable used is specified according to IP67, NEMA Type 4X.
- ▶ The IP protection classes are only maintained if the dummy cap is used or the cable is connected.

6.4 Post-connection check

After wiring the device, perform the following checks:

- Is the potential matching line connected?
- Is the terminal assignment correct?
- Are the cable glands and dummy plugs leak-tight?
- Are the fieldbus connectors properly secured?
- Are the covers screwed down correctly?

7 Operation options

7.1 Overview of operation options

- Operation via operating keys and DIP switches on the electronic insert
- Operation via Bluetooth® wireless technology (with optional Bluetooth device display) with Smartblue app or FieldXpert, DeviceCare
- Operation via operating tool (Endress+Hauser FieldCare/DeviceCare or AMS, PDM, etc.)
- Operation via handheld, Fieldcare, DeviceCare, AMS and PDM

7.2 Operating keys and DIP switches on the electronic insert

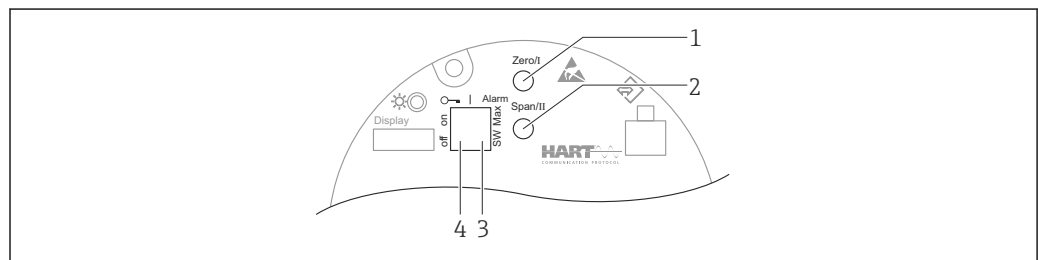

A0039285

- 1 Operating key for lower range value (Zero)
- 2 Operating key for upper range value (Span)
- 3 DIP switch for alarm current
- 4 DIP switch for locking and unlocking the device

i The setting of the DIP switches has priority over the settings made via other operation methods (e.g. FieldCare/DeviceCare).

7.3 Structure and function of the operating menu

More elaborate applications can be configured with the Endress+Hauser FieldCare or DeviceCare tools and Bluetooth and the SmartBlue App.

"Wizards" help the user to commission the various applications. The user is guided through the individual configuration steps.

7.3.1 User roles and related access authorization

The two user roles, **Operator** and **Maintenance** (order configuration), have different write access to the parameters if a device-specific access code has been defined. This access code protects the device configuration from unauthorized access.

If an incorrect access code is entered, the user retains the **Operator** option user role.

7.4 Access to the operating menu via the local display

7.4.1 Device display (optional)

Functions:

Display of measured values and fault and notice messages

i The device displays are available with the additional option of Bluetooth® wireless technology.

Depending on the supply voltage and the current consumption, Bluetooth can optionally be switched on or off.

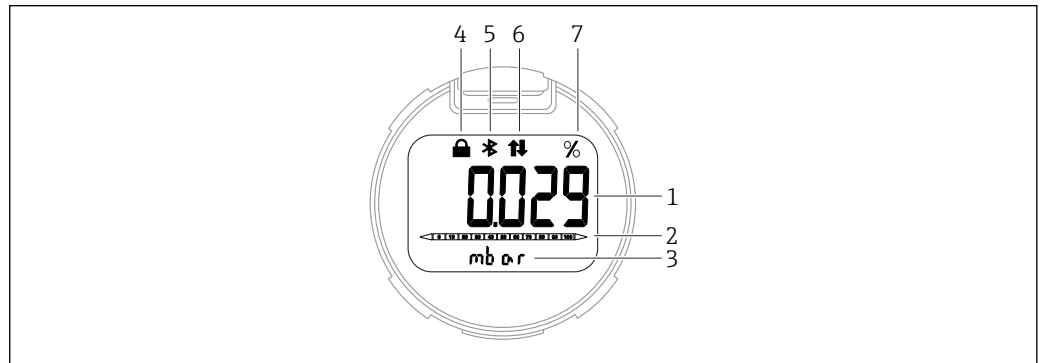

6 Segment display

- 1 Measured value (up to 5 digits)
- 2 Bar graph proportional to the current output
- 3 Unit of measured value
- 4 Locked (symbol appears when the device is locked)
- 5 Bluetooth (symbol flashes if Bluetooth connection is active)
- 6 HART communication (symbol is displayed if HART communication is active)
- 7 Measured value output in %

7.4.2 Operation via Bluetooth® wireless technology (optional)

Requirement

- Device with Bluetooth display
- Smartphone or tablet with Endress+Hauser SmartBlue app or PC with DeviceCare from version 1.07.00 or FieldXpert SMT70

The connection has a range of up to 25 m (82 ft). The range can vary depending on environmental conditions such as attachments, walls or ceilings.

SmartBlue app

1. Scan the QR code or enter "SmartBlue" in the search field of the App Store or Google Play.

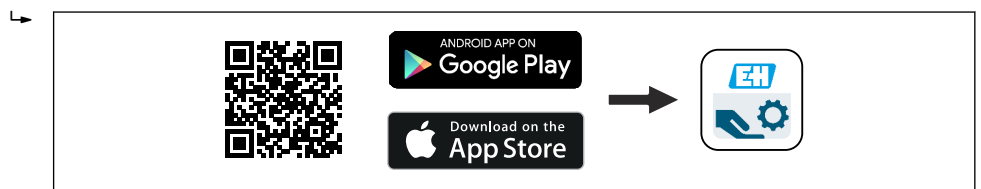

2. Start the SmartBlue app.
3. Select device from livelist displayed.
4. Login:
 - ↳ Enter the user name: admin
 - Password: serial number of the device.

5. Change the password after logging in for the first time!

Prerequisites

System requirements

The SmartBlue app is available to download for smartphones or tablets. For information on the compatibility of the SmartBlue App with mobile end devices, see "App Store (Apple)" or "Google Play Store".

Initial password

The serial number of the device serves as the initial password when the connection is established for the first time.

7.5 Access to the operating menu via the operating tool

The structure of the operating menu in the operating tools is the same as for operation via the local display. The range of functions is different however.

7.5.1 Connecting the operating tool

Service interface

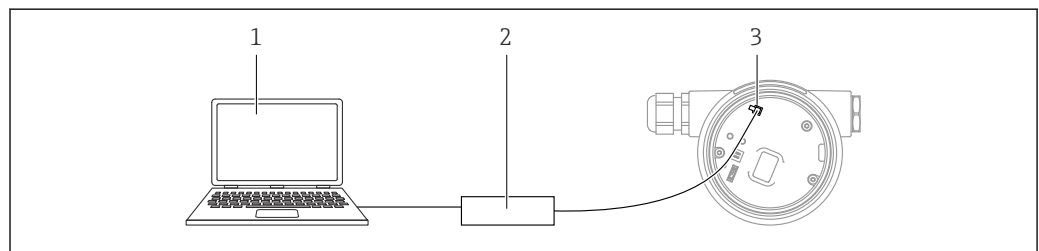

- 1 Computer with FieldCare/DeviceCare operating tool
- 2 Commubox FXA291
- 3 Service interface (CDI) of the device (= Endress+Hauser Common Data Interface)

i At least 22 mA is required to update (flash) the device firmware.

7.5.2 FieldCare

Range of functions

FDT-based plant asset management tool from Endress+Hauser. FieldCare can configure all intelligent field devices in a system and helps you manage them. By using the status information, FieldCare is also a simple but effective way of checking their status and condition.

Access is via:

- CDI service interface
- HART communication

Typical functions:

- Transmitter parameter configuration
- Loading and saving of device data (upload/download)
- Documentation of the measuring point
- Visualization of the measured value memory (line recorder) and event logbook

b For additional information about FieldCare, see Operating Instructions BA00027S and BA00059S.

7.5.3 DeviceCare

Range of functions

Tool for connecting and configuring Endress+Hauser field devices

Together with the device type managers (DTMs), DeviceCare presents a convenient, comprehensive solution.



For details, see Innovation Brochure IN01047S.

8 System integration

8.1 Overview of device description files

- Manufacturer ID: 17 (0x0011)
- Device type ID: 0x112A
- HART specification: 7.6
- DD files, information and files can be found at:
 - www.endress.com
 - www.fieldcommgroup.org

8.2 Measured variables via HART protocol

The following measured values are assigned to the device variables at the factory:

Device variable	Measured value
Primary variable (PV) ¹⁾	Pressure ²⁾
Secondary variable (SV)	Sensor temperature
Tertiary variable (TV)	Electronics temperature
Quaternary variable (QV)	Sensor pressure ³⁾

- 1) The PV is always applied to the current output.
- 2) The pressure is the calculated signal after damping and position adjustment.
- 3) The Sensor pressure is the raw signal of the measuring cell before damping and position adjustment.

 The assignment of the measured values to the device variables can be changed in the following submenu:
Application → HART output → HART output

 In a HART Multidrop loop, only one device may use the analog current value for signal transmission. For all other devices in the "**Loop current mode**" parameter, select the **Disable** option.

8.2.1 Device variables and measured values

The following codes are assigned to the device variables at the factory:

Device variable	Device variable code
Pressure	0
Scaled variable	1
Sensor temperature	2
Sensor pressure	3
Electronics temperature	4
Terminal current	5
Terminal voltage	6
Median of pressure signal	7
Noise of pressure signal	8
Percent of range	244

Device variable	Device variable code
Loop current	245
Not used	250

 The device variables can be queried by a HART® master using HART® command 9 or 33.

8.2.2 System units

The following table describes the supported pressure measuring units.

Index number	Description	Hart unit code
0	mbar	8
1	bar	7
2	Pa	11
3	kPa	12
4	MPa	237
5	psi	6
6	torr	13
7	atm	14
8	mmH2O	4
9	mmH2O (4°C)	239
10	mH2O	240
11	mH2O (4°C)	240
10	ftH2O	3
11	inH2O	1
12	inH2O (4°C)	238
13	mmHg	5
14	inHg	2
15	gf/cm ²	9
16	kgf/cm ²	10

9 Commissioning

9.1 Preliminaries

The measuring range and the unit in which the measured value is transmitted correspond to the data on the nameplate.

WARNING

The settings of the current output are relevant for safety!

This situation can result in product overflow.

- ▶ The setting of the current output depends on the setting in the **Assign PV** parameter.
- ▶ After changing the **Assign PV** parameter, check the settings for the range (LRV and URV) and reconfigure them if necessary.

WARNING

Process pressure above or below permitted maximum/minimum!

Risk of injury if parts burst! Warnings are displayed if the pressure is too high.

- ▶ If a pressure smaller than the minimum permitted pressure or greater than the maximum permitted pressure is present at the device, a message is output.
- ▶ Only use the device within the measuring range limits!

9.1.1 As-delivered state

If no customized settings were ordered:

- **Assign PV** parameter **Pressure** option
- Calibration values defined by defined measuring cell nominal value
- The alarm current is set to min. (3.6 mA), (only if no other option was selected when ordering)
- DIP switch to Off position
- If Bluetooth is ordered, then Bluetooth is switched on

9.2 Function check

Perform a function check before putting the measuring point into operation:

- "Post-installation check" checklist (see the "Installation" section)
- "Post-connection check" checklist (see the "Electrical connection" section)

9.3 Establishing a connection via FieldCare and DeviceCare

9.3.1 Via HART protocol

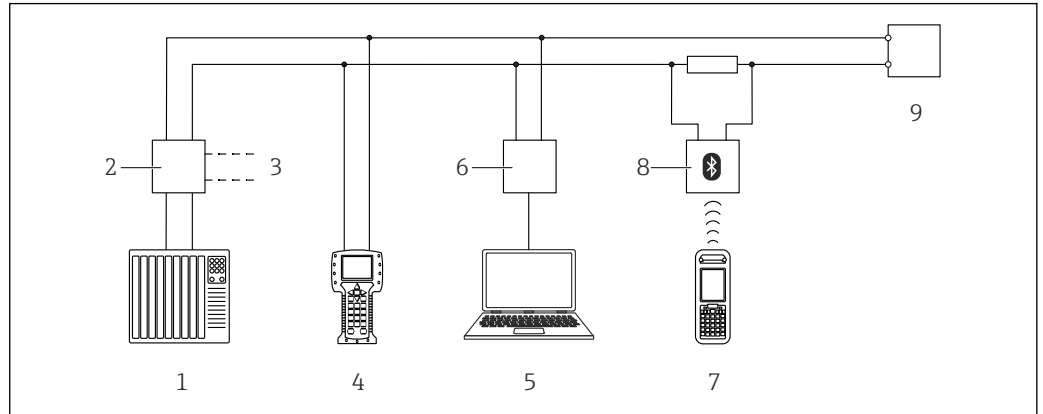

 7 Options for remote operation via HART protocol

- 1 PLC (programmable logic controller)
- 2 Transmitter power supply unit, e.g. RN221N (with communication resistor)
- 3 Connection for Commubox FXA195 and Field Communicator 375, 475
- 4 Field Communicator 475
- 5 Computer with operating tool (e.g. FieldCare/DeviceCare, AMS Device Manager, SIMATIC PDM)
- 6 Commubox FXA195 (USB)
- 7 Field Xpert SFX350/SFX370
- 8 VIATOR Bluetooth modem with connecting cable
- 9 Device

9.3.2 FieldCare/DeviceCare via service interface (CDI)

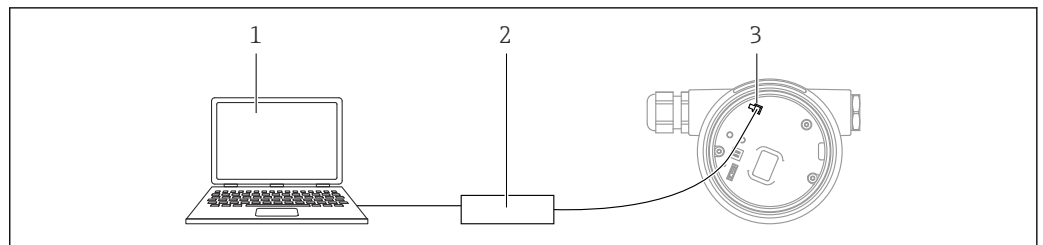

- 1 Computer with FieldCare/DeviceCare operating tool
- 2 Commubox FXA291
- 3 Service interface (CDI) of the device (= Endress+Hauser Common Data Interface)

 At least 22 mA is required to update (flash) the device firmware.

9.4 Configuring the device address via software

See the **HART address** parameter.

Menu path: Application → HART output → Configuration → HART address

9.5 Setting the operating language

9.5.1 Operating tool

See the description of the operating tool.

9.6 Configuring the device

9.6.1 Commissioning with keys on the electronic insert

The following functions are possible via the keys on the electronic insert:

- Position adjustment (zero point correction)
 - The orientation of the device may cause a pressure shift
 - This pressure shift can be corrected by a position adjustment
- Setting the lower range value and upper range value
 - The pressure applied must be within the nominal pressure limits of the sensor (see the specifications on the nameplate)
- Resetting the device

Carrying out position adjustment

1. Device installed in desired position and no pressure applied.
2. Press the "Zero" and "Span" keys simultaneously for at least 3 s.
3. When the LED lights up briefly, the pressure present has been accepted for position adjustment.

Setting the lower range value (pressure or scaled variable)

1. The desired pressure for the lower range value is present at the device.
2. Press the "Zero" key for at least 3 s.
3. When the LED lights up briefly, the pressure present has been accepted for the lower range value.

Setting the upper range value (pressure or scaled variable)

1. The desired pressure for the upper range value is present at the device.
2. Press the "Span" key for at least 3 s.
3. When the LED lights up briefly, the pressure present has been accepted for the upper range value.
4. Does the LED on the electronic insert not light up?
 - ↳ Applied pressure for upper range value has not been accepted.
 - Wet calibration is not possible if the **Scaled variable** option has been selected in the **Assign PV** parameter and the **Table** option has been selected in the **Scaled variable transfer function** parameter.

Checking the settings (pressure or scaled variable)

1. Press the "Zero" key briefly (approx. 1 second) in order to display the lower range value.
2. Press the "Span" key briefly (approx. 1 second) in order to display the upper range value.
3. Briefly press the "Zero" and "Span" keys simultaneously (approx. 1 second) in order to display the position offset.

Resetting the device

- ▶ Press and hold the "Zero" and "Span" keys simultaneously for at least 12 seconds.

9.6.2 Commissioning with the Commissioning wizard

In FieldCare, DeviceCare ¹⁾, SmartBlue and on the display, the **Commissioning** wizard is available to guide the user through the initial commissioning steps. Commissioning is also possible via AMS or PDM.

1. Connect the device with FieldCare or DeviceCare.
 2. Open the device in FieldCare or DeviceCare.
 - ↳ The dashboard (homepage) of the device is displayed:
 3. In the **Guidance** menu, click the **Commissioning** wizard to open the wizard.
 4. Enter the appropriate value in each parameter or select the appropriate option. These values are written directly to the device.
 5. Click "Next" to go to the next page.
 6. Once all the pages have been completed, click "End" to close the **Commissioning** wizard.
-  If the **Commissioning** wizard is cancelled before all the necessary parameters have been configured, the device may be in an undefined state. In such situations, it is advisable to reset the device to the factory default settings.

1) DeviceCare is available for download at www.software-products.endress.com. You must register in the Endress+Hauser software portal to download the product.

Example: Outputting of the pressure value at the current output

i Pressure and temperature units are converted automatically. Other units are not converted.

In the following example, the pressure value should be measured in a tank and output on the current output. The maximum pressure of 450 mbar (6.75 psi) corresponds to the 20 mA current. The 4 mA current corresponds to a pressure of 50 mbar (0.75 psi).

Prerequisites:

- Measured variable in direct proportion to the pressure
- Due to the orientation of the device, there may be pressure shifts in the measured value (when the vessel is empty or partly filled, the measured value is not zero)
Perform a position adjustment if necessary
- In the **Assign PV** parameter, the **Pressure** option must be selected (factory setting)
Display: In the **Guidance** menu **Commissioning** wizard, keep pressing the \oplus key until you reach the **Assign PV** parameter. Press the \boxtimes key to confirm, select the **Pressure** option and press \boxtimes to confirm.

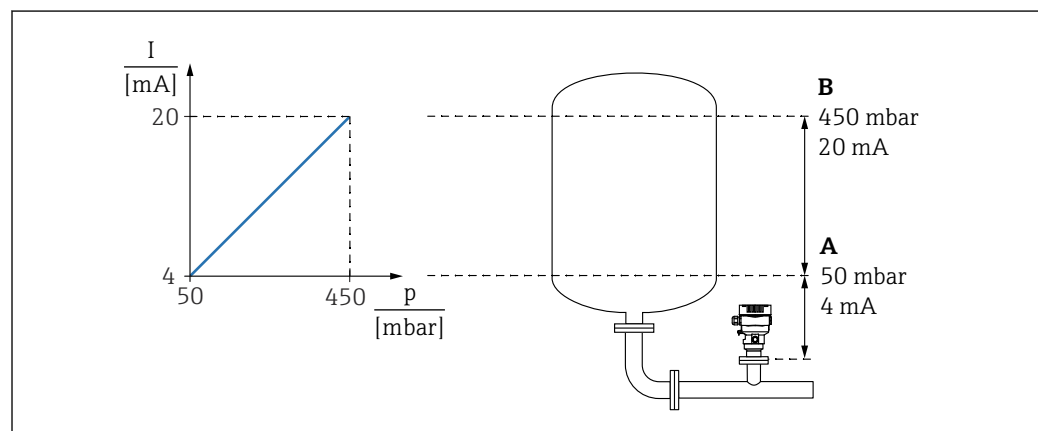

- A Lower range value output
B Upper range value output

Adjustment:

1. Enter the pressure value for the 4 mA current via the **Lower range value output** parameter (50 mbar (0.75 psi)).
2. Enter the pressure value for the 20 mA current via the **Upper range value output** parameter (450 mbar (6.75 psi))

Result: The measuring range is set to 4 to 20 mA.

9.6.3 Commissioning without the commissioning wizard**Example: Commissioning a volume measurement in the tank**

i Pressure and temperature units are converted automatically. Other units are not converted.

In the following example, the volume in a tank should be measured in liters. The maximum volume of 1 000 l (264 gal) corresponds to a pressure of 450 mbar (6.75 psi).

The minimum volume of 0 liters corresponds to a pressure of 50 mbar (0.75 psi).

Prerequisites:

- Measured variable in direct proportion to the pressure
- Due to the orientation of the device, there may be pressure shifts in the measured value (when the vessel is empty or partly filled, the measured value is not zero)
Perform position adjustment if necessary

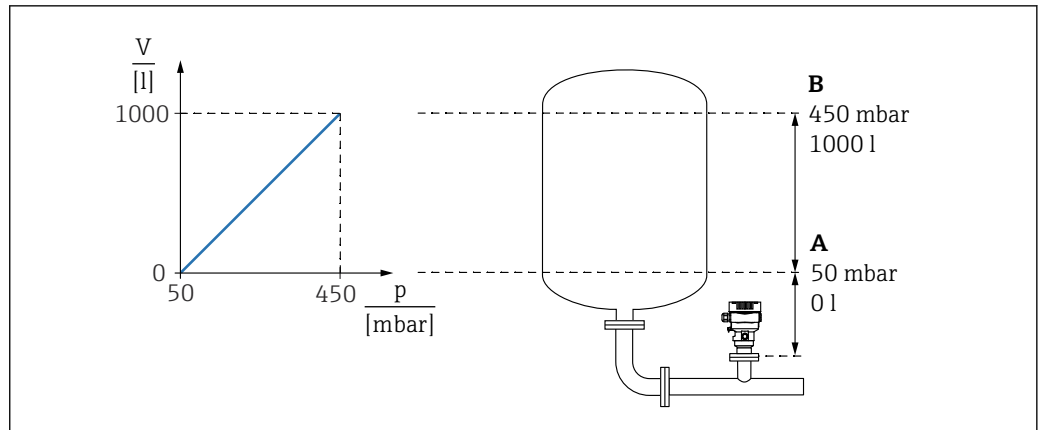

A "Pressure value 1" parameter and "Scaled variable value 1" parameter

B "Pressure value 2" parameter and "Scaled variable value 2" parameter

i The pressure present is displayed in the operating tool on the same settings page in the "Pressure" field.

1. Enter the pressure value for the lower calibration point via the **Pressure value 1** parameter: 50 mbar (0.75 psi)
↳ Menu path: Application → Sensor → Scaled variable → Pressure value 1
2. Enter the volume value for the lower calibration point via the **Scaled variable value 1** parameter: 0 l (0 gal)
↳ Menu path: Application → Sensor → Scaled variable → Scaled variable value 1
3. Enter the pressure value for the upper calibration point via the **Pressure value 2** parameter: 450 mbar (6.75 psi)
↳ Menu path: Application → Sensor → Scaled variable → Pressure value 2
4. Enter the volume value for the upper calibration point via the **Scaled variable value 2** parameter: 1000 l (264 gal)
↳ Menu path: Application → Sensor → Scaled variable → Scaled variable value 2

Result: The measuring range is set for 0 to 1000 l (0 to 264 gal). Only the **Scaled variable value 1** parameter and **Scaled variable value 2** parameter are set with this setting. This setting has no effect on the current output.

9.6.4 Linearization

In the following example, the volume in a tank with a conical outlet should be measured in m^3 .

Prerequisites:

- Points for linearization table are known.
- Level calibration is performed.
- Linearization characteristic must continually increase or decrease.

⚠ WARNING

The settings of the current output are relevant for safety!

This situation can result in product overflow.

- ▶ The setting of the current output depends on the setting in the **Assign PV** parameter.
- ▶ After changing the **Assign PV** parameter, check the settings for the range (LRV and URV) and reconfigure them if necessary.

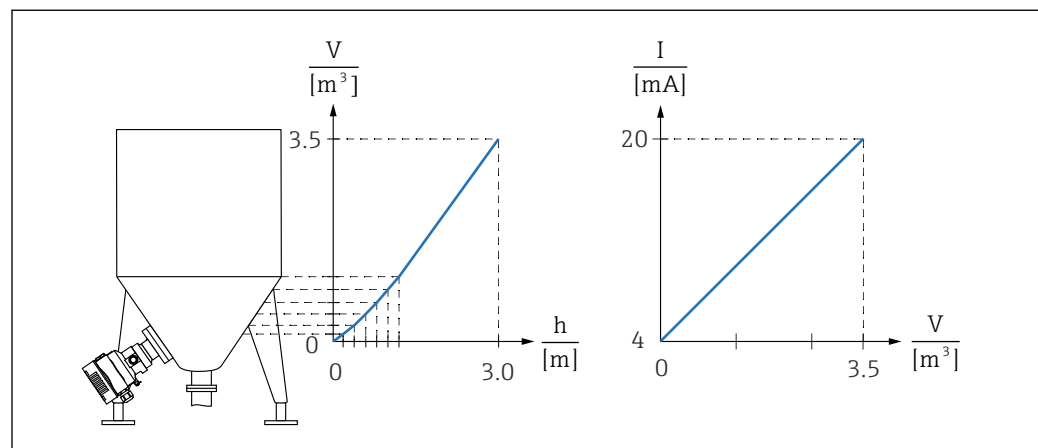

A0038910

1. In the **Assign PV** parameter, the **Scaled variable** option must be configured.
 - ↳ Menu path: Application → HART output → HART output → Assign PV
2. In the **Scaled variable unit** parameter, set the desired unit.
 - ↳ Menu path: Application → Sensor → Scaled variable → Scaled variable unit
3. The linearization table can be opened via the **Go to linearization table** parameter **Table** option.
 - ↳ Menu path: Application → Sensor → Scaled variable → Scaled variable transfer function
4. Enter the desired table values.
5. The table is activated once all the points in the table have been entered.
6. Activate the table using the **Activate table** parameter.

Result:

The measured value after linearization is displayed.

- i** ▪ Error message F435 "Linearization" and the alarm current appear as long as the table is being entered and until the table is activated.
- The 0% value (= 4 mA) is defined by the smallest point in the table. The 100% value (= 20 mA) is defined by the largest point in the table.
- The assignment of the volume/mass values to the current values can be changed with the **Lower range value output** parameter and **Upper range value output** parameter

9.7 "Simulation" submenu

With the **Simulation** submenu, the pressure, current and diagnostic events can be simulated.

Menu path: Diagnostics → Simulation

9.8 Protecting settings from unauthorized access

9.8.1 Hardware locking or unlocking

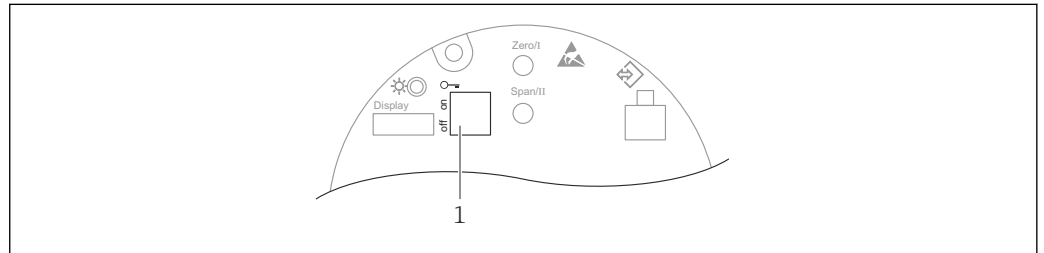

A0043441

1 DIP switch for locking and unlocking the device

DIP switch 1 on the electronic insert is used to lock or unlock operation.

If operation is locked via the DIP switch, you can only unlock operation again via the DIP switch.

If operation is locked via the operating menu, you can only unlock operation again via the operating menu.

If operation is locked via the DIP switch, the key symbol  appears on the local display.

Sealing the device

The housing cover is designed to be sealed for use in custody transfer.

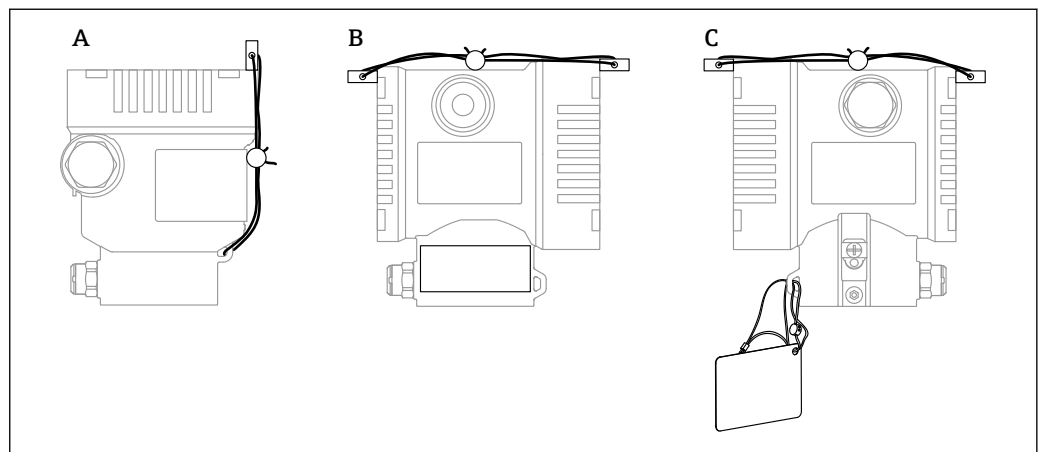

A0038742

A Single compartment housing

B Dual compartment housing

9.8.2 Software locking or unlocking

 If operation is locked by means of the DIP switch, you can only unlock operation again by means of the DIP switch.

Locking via password in display / FieldCare / DeviceCare / SmartBlue

Access to the device configuration can be locked by assigning a password. The user role is set to **Maintenance** option when the device is delivered to the customer. The device can be fully configured with the **Maintenance** option user role. Afterwards, access to the configuration can be locked by assigning a password. The lock sets the **Maintenance** option to the **Operator** option. The configuration can be accessed by entering the password.

The password is defined under:

System menu **User management** submenu

The user role can be changed from **Maintenance** option to **Operator** option under:

System → User management

Disabling the lock via the display / FieldCare / DeviceCare / SmartBlue

Once the password is entered, you can enable the configuration of the device as an **Operator** option by entering the password. The user role then changes to **Maintenance** option.

The password can be deleted if necessary in the **User management** submenu: System → User management

10 Operation

10.1 Reading off the device locking status

Displaying active write protection:

- In the **Locking status** parameter
 - Menu path of local display: at the top operating level
 - Menu path of operating tool: System → Device management
- In the operating tool (FieldCare/DeviceCare) in the DTM header

10.2 Reading off measured values

All the measured values can be read off using the **Measured values** submenu.

Navigation

"Application" menu → Measured values

10.3 Adapting the device to process conditions

The following are available for this purpose:

- Basic settings using the **Guidance** menu
- Advanced settings using the **Diagnostics** menu, **Application** menu and **System** menu

10.3.1 Sensor calibration ²⁾

In the course of their life cycle, pressure sensors **can** deviate, or drift, ³⁾ from the original pressure characteristic curve. This deviation depends on the operating conditions and can be corrected in the **Sensor calibration** submenu.

Set the value of the zero point shift to 0.00 before the Sensor calibration. Application

→ Sensor → Sensor calibration → Zero adjustment offset

1. Apply the lower pressure value (value measured with pressure reference) to the device. Enter this pressure value in the **Lower sensor trim** parameter. Application → Sensor → Sensor calibration → Lower sensor trim
 - ↳ The value entered causes a parallel shift of the pressure characteristic in relation to the current Sensor calibration.
2. Apply the upper pressure value (value measured with pressure reference) to the device. Enter this pressure value in the **Upper sensor trim** parameter. Application → Sensor → Sensor calibration → Upper sensor trim
 - ↳ The value entered causes a change in the slope of the current Sensor calibration.

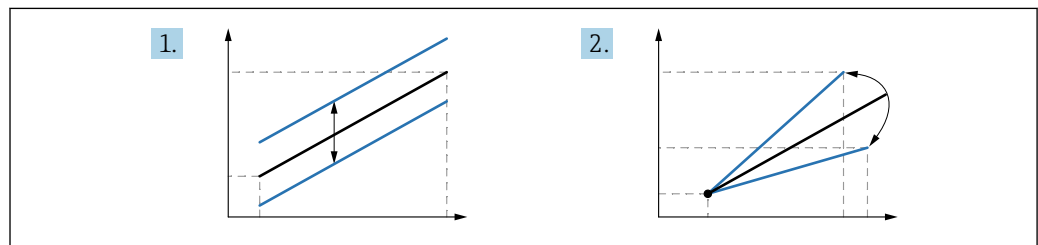

A0052045

i The accuracy of the pressure reference determines the accuracy of the device. The pressure reference must be more accurate than the device.

2) Not possible with display.

3) Deviations caused by physical factors are also known as "Sensor drift".

11 Diagnosis and troubleshooting

11.1 General troubleshooting

11.1.1 General errors

Device not responding

- Possible cause: Supply voltage does not match the specification on the nameplate
Remedial action: Apply the correct voltage
- Possible cause: The polarity of the supply voltage is wrong
Remedial action: Correct the polarity
- Possible cause: The cables do not contact the terminals properly
Remedial action: Check the electrical contact between cables and correct if necessary
- Possible cause: Load resistance too high
Remedial action: Increase the supply voltage to reach the minimum terminal voltage

No values visible on the display

- Possible cause: The plug of the display cable is not connected correctly
Remedial action: Connect the plug correctly
- Possible cause: Display is defective
Remedial action: Replace the display

"Communication error" is indicated on the display when the device is started or the display is connected

- Possible cause: Electromagnetic interference influence
Remedial action: Check grounding of the device
- Possible cause: Defective cable connection or display plug
Remedial action: Replace the display

HART communication not working

- Possible cause: Communication resistor missing or incorrectly installed
Remedial action: Install the communication resistor (250 Ω) correctly
- Possible cause: Commubox is connected incorrectly
Remedial action: Connect Commubox correctly

Communication via CDI interface not working

Possible cause: Wrong setting of the COM port on the computer

Remedial action: Check the setting of the COM port on the computer and correct it if necessary

11.1.2 Error - SmartBlue operation

Operation via SmartBlue is only possible on devices that have a display with Bluetooth (optionally available).

Device is not visible in the live list

- Possible cause: Supply voltage too low
Remedial action: Increase the supply voltage.
- Possible cause: No Bluetooth connection available
Remedial action: Enable Bluetooth in the field device via display or software tool and/or in the smartphone/tablet
- Possible cause: Bluetooth signal outside range
Remedial action: Reduce distance between field device and smartphone/tablet
The connection has a range of up to 25 m (82 ft)
- Possible cause: Geopositioning is not enabled on Android devices or is not permitted for the SmartBlue app.
Remedial action: Enable/permit the geopositioning service on Android device for the SmartBlue app.

Device appears in the live list but a connection cannot be established

- Possible cause: The device is already connected with another smartphone/tablet via Bluetooth.

Only one point-to-point connection is permitted

Remedial action: Disconnect the smartphone/tablet from the device

- Possible cause: Incorrect user name and password

Remedial action: The standard user name is "admin" and the password is the device serial number indicated on the device nameplate (only if the password was not changed by the user beforehand)

If the password has been forgotten: → 📖 60

Connection via SmartBlue not possible

- Possible cause: Incorrect password entered

Remedial action: Enter the correct password, paying attention to lower/upper case

- Possible cause: Forgotten password

Remedial action: → 📖 60

No communication with device via SmartBlue

- Possible cause: Supply voltage too low

Remedial action: Increase the supply voltage.

- Possible cause: No Bluetooth connection available

Remedial action: Enable the Bluetooth function on the smartphone, tablet and device

- Possible cause: The device is already connected with another smartphone/tablet

Remedial action: Disconnect the device from the other smartphone/tablet

- Ambient conditions (e.g. walls/tanks) disturbing the Bluetooth connection

Remedial action: Establish direct line-of-sight connection

- Display does not have Bluetooth

Device cannot be operated via SmartBlue

- Possible cause: Incorrect password entered

Remedial action: Enter the correct password, paying attention to lower/upper case

- Possible cause: Forgotten password

Remedial action: → 📖 60

- Possible cause: **Operator** option has no authorization.

Remedial action: Change to the **Maintenance** option.

11.1.3 Additional tests

If no clear cause of the error can be identified or the source of the problem can be both the device and the application, the following additional tests can be performed:

1. Check the digital pressure value (display, HART, ..).
2. Check that the device concerned is functioning correctly. Replace the device if the digital value does not correspond to the expected pressure value.
3. Switch on the simulation and check the current output. Replace the main electronics if the current output does not correspond to the simulated value.

11.1.4 Response of current output to errors

The response of the current output to errors is defined by the **Failure behavior current output** parameter.

Parameter overview with brief description

Parameter	Description	Selection / User entry
Failure behavior current output	Defines which current the output assumes in the case of an error. Min: < 3.6 mA Max: >21.5 mA Note: The hardware DIP Switch for alarm current has priority over software setting.	<ul style="list-style-type: none">■ Min.■ Max.
Failure current	Enter current output value in alarm condition.	21.5 to 23 mA

11.2 Diagnostic information on local display

11.2.1 Diagnostic message

Measured value display and diagnostic message in alarm condition

Faults detected by the device's self-monitoring system are displayed as a diagnostic message in alternation with the unit.

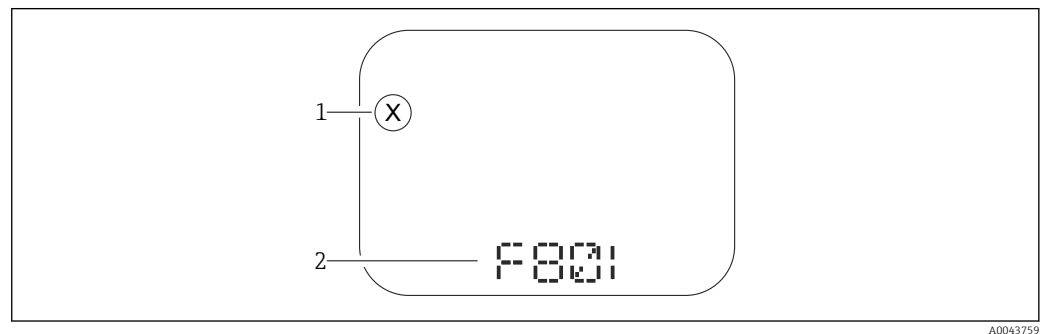

- 1 Status signal
2 Status symbol with diagnostic event

Status signals

F

"Failure (F)" option

A device error has occurred. The measured value is no longer valid.

C

"Function check (C)" option

The device is in the service mode (e.g. during a simulation).

S

"Out of specification (S)" option

The device is being operated:

- Outside of its technical specifications (e.g. during startup or a cleaning)
- Outside of the configuration performed by the user (e.g. level outside configured span)

M

"Maintenance required (M)" option

Maintenance required. The measured value remains valid.

11.3 Diagnostic event in the operating tool

If a diagnostic event has occurred in the device, the status signal appears in the top left status area of the operating tool together with the corresponding symbol for the event level according to NAMUR NE 107:

- Failure (F)
- Function check (C)
- Out of specification (S)
- Maintenance required (M)

Click the status signal to see the detailed status signal.

The diagnostic events and remedial measures can be printed out in the **Diagnostic list** submenu.

11.4 Adapting the diagnostic information

The event level can be configured:

Menu path: Diagnostics → Diagnostic settings → Configuration

11.5 Queued diagnostic messages

The display alternates between the queued diagnostic messages and the measured value.

Queued diagnostic messages can also be displayed in the **Active diagnostics** parameter.

Menu path: Diagnostics → Active diagnostics

11.6 Diagnostic list

All of the diagnostic messages currently pending can be displayed in the **Diagnostic list** submenu.

Navigation path

Diagnostics → Diagnostic list

11.6.1 List of diagnostic events

Diagnostic number	Short text	Remedy instructions	Status signal [from the factory]	Diagnostic behavior [from the factory]
Diagnostic of sensor				
062	Sensor connection faulty	Check sensor connection	F	Alarm
081	Sensor initialization faulty	1. Restart device 2. Contact service	F	Alarm
100	Sensor error	1. Restart the device 2. Contact Endress+Hauser Service	F	Alarm
101	Sensor temperature	1. Check process temperature 2. Check ambient temperature	F	Alarm
102	Sensor incompatible error	1. Restart device 2. Contact service	F	Alarm
Diagnostic of electronic				
203	HART Device Malfunction	Check device specific diagnosis.	S	Warning
204	HART Electronic Defect	Check device specific diagnosis.	F	Alarm
242	Firmware incompatible	1. Check software 2. Flash or change main electronic module	F	Alarm
252	Module incompatible	1. Check if correct electronic module is plugged 2. Replace electronic module	F	Alarm
263	Incompatibility detected	Check electronic module type	M	Warning
270	Main electronics defective	Replace main electronics	F	Alarm
272	Main electronics faulty	1. Restart device 2. Contact service	F	Alarm
273	Main electronics defective	Replace main electronics	F	Alarm
282	Data storage inconsistent	Restart device	F	Alarm
283	Memory content inconsistent	1. Restart device 2. Contact service	F	Alarm
287	Memory content inconsistent	1. Restart device 2. Contact service	M	Warning
388	Electronics and HistoROM defective	1. Restart device 2. Replace electronics and HistoROM 3. Contact service	F	Alarm
Diagnostic of configuration				
410	Data transfer failed	1. Retry data transfer 2. Check connection	F	Alarm
412	Processing download	Download active, please wait	C	Warning
420	HART Device Configuration Locked	Check device locking configuration.	S	Warning
421	HART Loop Current fixed	Check Multi-drop mode or current simulation.	S	Warning
431	Trim required	Carry out trim	C	Warning
435	Linearization faulty	Check data points and min span	F	Alarm

Diagnostic number	Short text	Remedy instructions	Status signal [from the factory]	Diagnostic behavior [from the factory]
437	Configuration incompatible	1. Update firmware 2. Execute factory reset	F	Alarm
438	Dataset different	1. Check dataset file 2. Check device parameterization 3. Download new device parameterization	M	Warning
441	Current output 1 saturated	1. Check process 2. Check current output settings	S	Warning
484	Failure mode simulation active	Deactivate simulation	C	Alarm
485	Process variable simulation active	Deactivate simulation	C	Warning
491	Current output simulation active	Deactivate simulation	C	Warning
495	Diagnostic event simulation active	Deactivate simulation	S	Warning
500	Process alert pressure	1. Check process pressure 2. Check configuration of process alert	S	Warning ¹⁾
501	Process alert scaled variable	1. Check process conditions 2. Check scaled variable configuration	S	Warning ¹⁾
502	Process alert temperature	1. Check process temperature 2. Check configuration of process alert	S	Warning ¹⁾
503	Zero adjustment	1. Check measuring range 2. Check position adjustment	M	Warning
Diagnostic of process				
801	Supply voltage too low	Increase supply voltage	F	Alarm
802	Supply voltage too high	Decrease supply voltage	S	Warning
805	Loop current faulty	1. Check wiring 2. Replace electronics	F	Alarm
806	Loop diagnostics	1. Check supply voltage 2. Check wiring and terminals	M	Warning ¹⁾
807	No Baseline due to insuf. volt. at 20 mA	Increase supply voltage	M	Warning
822	Sensor temperature out of range	1. Check process temperature 2. Check ambient temperature	S	Warning ¹⁾
825	Electronics temperature	1. Check ambient temperature 2. Check process temperature	S	Warning
841	Operating range	1. Check the process pressure 2. Check the sensor range	S	Warning ¹⁾
846	HART Non-Primary Variable Out of Limit	Check device specific diagnosis.	S	Warning
847	HART Primary Variable Out of Limit	Check device specific diagnosis.	S	Warning
848	HART Device Variable Alert	Check device specific diagnosis.	S	Warning
900	High signal noise detected	1. Check impulse line 2. Check valve position 3. Check process	M	Warning ¹⁾

Diagnostic number	Short text	Remedy instructions	Status signal [from the factory]	Diagnostic behavior [from the factory]
901	Low signal noise detected	1. Check impulse line 2. Check valve position 3. Check process	M	Warning ¹⁾
902	Min signal noise detected	1. Check impulse line 2. Check valve position 3. Check process	M	Warning ¹⁾
906	Out of range signal detected	1. Process Information. No action 2. Rebuild baseline 3. Adapt signal range thresholds	S	Warning ¹⁾

1) Diagnostic behavior can be changed.

11.7 Event logbook

11.7.1 Event history

The **Event list** submenu provides a chronological overview of the event messages that have occurred⁴⁾.

Navigation path

Diagnostics → Event logbook

A maximum of 100 event messages can be displayed in chronological order.

The event history includes entries for:

- Diagnostic events
- Information events

In addition to the operating time when the event occurred, each event is also assigned a symbol that indicates whether the event has occurred or is finished:

- Diagnostic event
 - ☺: Occurrence of the event
 - ☹: End of the event
- Information event
 - ☺: Occurrence of the event

11.7.2 Filtering the event logbook

Filters can be used to determine which category of event messages is displayed in the **Event list** submenu.

Navigation path

Diagnostics → Event logbook

11.7.3 Overview of information events

Info number	Info name
I1000	----- (Device ok)
I1079	Sensor changed
I1089	Power on
I1090	Configuration reset

4) If operating via FieldCare, the event list can be displayed with the "Event List/HistoROM" function in FieldCare.

Info number	Info name
I1091	Configuration changed
I11074	Device verification active
I1110	Write protection switch changed
I11104	Loop diagnostics
I11284	DIP MIN setting to HW active
I11285	DIP SW setting active
I11341	SSD baseline created
I1151	History reset
I1154	Reset terminal voltage min/max
I1155	Reset electronics temperature
I1157	Memory error event list
I1256	Display: access status changed
I1264	Safety sequence aborted
I1335	Firmware changed
I1397	Fieldbus: access status changed
I1398	CDI: access status changed
I1440	Main electronic module changed
I1444	Device verification passed
I1445	Device verification failed
I1461	Sensor verification failed
I1512	Download started
I1513	Download finished
I1514	Upload started
I1515	Upload finished
I1551	Assignment error fixed
I1552	Failed: Main electronic verification
I1554	Safety sequence started
I1555	Safety sequence confirmed
I1556	Safety mode off
I1956	Reset

11.7.4 Overview of information events

Info number	Info name
I1000	----- (Device ok)
I1079	Sensor changed
I1089	Power on
I1090	Configuration reset
I1091	Configuration changed
I11074	Device verification active
I1110	Write protection switch changed
I11104	Loop diagnostics
I11284	DIP MIN setting to HW active

Info number	Info name
I11285	DIP SW setting active
I11341	SSD baseline created
I1151	History reset
I1154	Reset terminal voltage min/max
I1155	Reset electronics temperature
I1157	Memory error event list
I1256	Display: access status changed
I1264	Safety sequence aborted
I1335	Firmware changed
I1397	Fieldbus: access status changed
I1398	CDI: access status changed
I1440	Main electronic module changed
I1444	Device verification passed
I1445	Device verification failed
I1461	Sensor verification failed
I1512	Download started
I1513	Download finished
I1514	Upload started
I1515	Upload finished
I1551	Assignment error fixed
I1552	Failed: Main electronic verification
I1554	Safety sequence started
I1555	Safety sequence confirmed
I1556	Safety mode off
I1956	Reset

11.8 Device reset

11.8.1 Resetting the device using the operating tool

Reset the device configuration - either entirely or in part - to a defined state

Navigation: System → Device management → Reset device

Reset device parameter

 For details see the "Description of device parameters" documentation.

11.8.2 Resetting the device via electronic insert keys

Resetting Bluetooth password and user role (SW 1/1/2000 and higher)

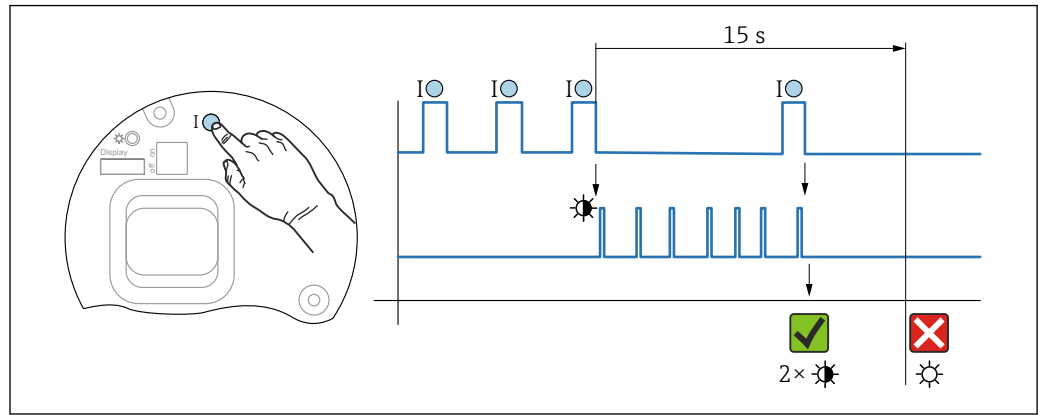

8 Sequence for resetting the password

Delete/reset the password

1. Press operating key I three times.
 - ↳ The reset password function is started, the LED flashes.
2. Within 15 s, press operating key I once.
 - ↳ The password is reset, and the LED flashes briefly.

If operating key I is not pressed within 15 s, the action is canceled and the LED goes out.

Resetting the device to the factory setting

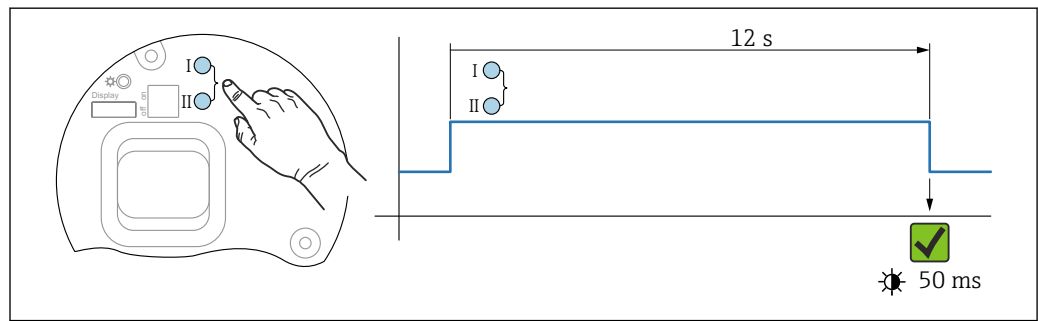

9 Operating keys on the electronic insert

Resetting the device to the factory setting

- ▶ Simultaneously press the I and II operating keys for at least 12 s.
 - ↳ Device data are reset to the factory setting, the LED flashes briefly.

11.9 Device information

All the device information is contained in the **Information** submenu.

Menu path: System → Information

For details see the "Description of device parameters" document.

11.10 Firmware history

 The firmware version can explicitly be ordered via the product structure. This makes it possible to ensure the compatibility of the firmware version with an existing or planned system integration.

11.10.1 Version 01.00.zz

Original software

11.10.2 Version 01.01.zz

- Heartbeat Technology extended functionality
- HART condensed status

12 Maintenance

12.1 Maintenance work

This chapter describes the maintenance of physical device components.

12.1.1 Pressure compensation filter

Keep the pressure compensation filter (1) free from contamination.

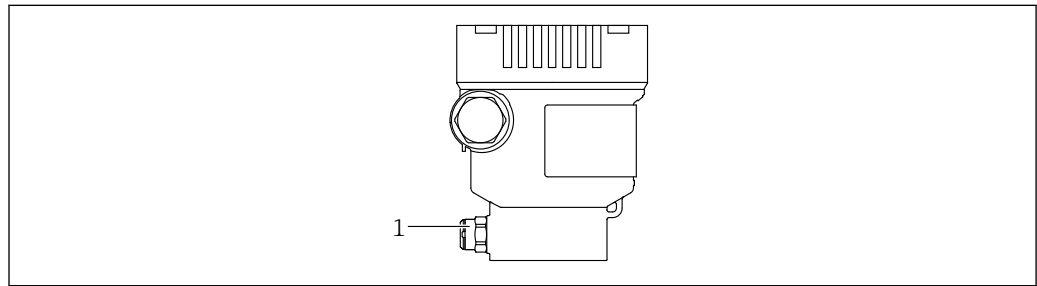

1 Pressure compensation filter

A0043756

12.1.2 Flushing rings

i The use of flushing rings allows the membrane to be cleaned without removing the device from the process.

For more information: contact the Endress+Hauser sales office.

12.1.3 Exterior cleaning

Notes on cleaning

- The cleaning agents used should not corrode the surfaces and the seals
- Mechanical damage to the membrane, e.g. due to sharp objects, must be avoided
- Observe the degree of protection of the device

13 Repair

13.1 General information

13.1.1 Repair concept

Under the Endress+Hauser repair concept, devices have a modular design and repairs are carried out by Endress+Hauser Service or by properly trained customers.

Spare parts are grouped into logical kits with the associated replacement instructions.

For more information on service and spare parts contact Endress+Hauser Service.

13.1.2 Repair of Ex-certified devices

WARNING

Incorrect repair can compromise electrical safety!

Explosion Hazard!

- ▶ Repairs to Ex-certified devices must be carried out by Endress+Hauser Service or by specialist personnel according to national regulations.
- ▶ Relevant standards and national regulations on hazardous areas, safety instructions and certificates must be observed.
- ▶ Use only original Endress+Hauser spare parts.
- ▶ Please note the device designation on the nameplate. Only identical parts may be used as replacements.
- ▶ Carry out repairs according to the instructions.
- ▶ Only the Endress+Hauser service team is permitted to modify a certified device and convert it to another certified version.

13.2 Spare parts

- Some replaceable device components are identified by a spare part nameplate. This contains information about the spare part.
- All the spare parts for the measuring device, along with the order code, are listed in the *Device Viewer* (www.endress.com/deviceviewer) and can be ordered. If available, users can also download the associated Installation Instructions.

-  Device serial number:
 - Located on the device and spare part nameplate.
 - Can be read out via the device software.

13.3 Replacement

CAUTION

Data upload/download is not permitted if the device is used for safety-related applications.

- ▶ After an entire device or an electronics module has been replaced, the parameters can be downloaded to the device again via the communication interface. For this, the data must have been uploaded to the PC beforehand using the "FieldCare/DeviceCare" software.

13.4 Return

The device must be returned in the event of a factory calibration, or if the wrong device has been ordered or delivered.

As an ISO-certified company and also due to legal regulations, Endress+Hauser is obliged to follow certain procedures when handling any returned products that have been in contact with medium. To ensure swift, safe and professional device returns, please read the return procedures and conditions on the Endress+Hauser website <http://www.endress.com/support/return-material>.

- ▶ Select country.
 - ↳ The website of the responsible sales office opens with all the relevant information relating to returns.
- 1. If the desired country is not listed:
 - Click on the "Choose your location" link.
 - ↳ An overview of Endress+Hauser sales offices and representatives opens.
- 2. Contact the Endress+Hauser sales organization responsible for your area.

13.5 Disposal

-  If required by the Directive 2012/19/EU on waste electrical and electronic equipment (WEEE), the product is marked with the depicted symbol in order to minimize the disposal of WEEE as unsorted municipal waste. Do not dispose of products bearing this marking as unsorted municipal waste. Instead, return them to the manufacturer for disposal under the applicable conditions.

14 Accessories

14.1 Device-specific accessories

14.1.1 Mechanical accessories

- Mounting bracket for housing
- Mounting bracket for block & bleed valves
- Block&Bleed valves:
 - Block&Bleed valves can be ordered as **enclosed** accessories (seal for mounting is enclosed)
 - Block&Bleed valves can be ordered as **mounted** accessories (mounted manifolds are supplied with a documented leak test)
 - Certificates (e.g. 3.1 material certificate and NACE) and tests (e.g. PMI and pressure test) that are ordered with the device apply for the transmitter and the manifold
 - During the operating life of the valves, it may be necessary to re-tighten the pack
- Water pocket pipes (PZW)
- Flushing rings
- Weather protection covers

 For technical data (e.g. materials, dimensions or order numbers), see the accessory document SD01553P.

14.1.2 Plug connectors

- Plug connector M12 90 deg, IP67 5m cable, union nut, Cu Sn/Ni
- Plug connector M12, IP67 union nut, Cu Sn/Ni
- Plug connector M12, 90 deg IP67 union nut, Cu Sn/Ni

 The IP protection classes are only maintained if the dummy cap is used or the cable is connected.

14.1.3 Weld-in accessory

 For details, refer to TI00426F/00/EN "Weld-in adapters, process adapters and flanges".

14.2 Device Viewer

All the spare parts for the device, along with the order code, are listed in the *Device Viewer* (www.endress.com/deviceviewer).

15 Technical data

15.1 Output

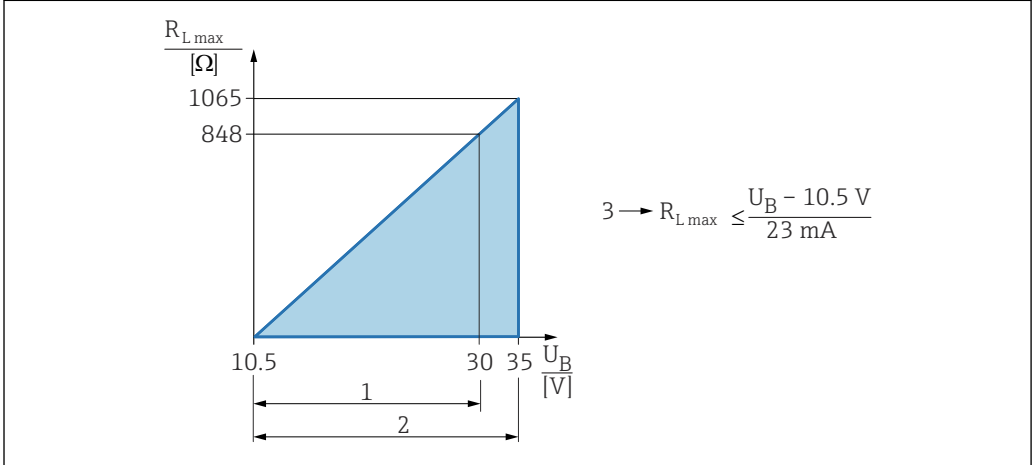
Output signal	<p>Current output</p> <p>4 to 20 mA with superimposed digital communication protocol HART, 2-wire</p> <p>The current output offers a choice of three different operating modes:</p> <ul style="list-style-type: none"> ■ 4.0 to 20.5 mA ■ NAMUR NE 43: 3.8 to 20.5 mA (factory setting) ■ US mode: 3.9 to 20.8 mA
Signal on alarm	<p>Signal on alarm in accordance with NAMUR recommendation NE 43.</p> <p>4 to 20 mA HART:</p> <p>Options:</p> <ul style="list-style-type: none"> ■ Max alarm: can be set from 21.5 to 23 mA ■ Min. alarm: < 3.6 mA (factory setting)
Load	<p>4 to 20 mA HART</p> <div style="text-align: center;">  </div> <p style="text-align: right; font-size: small;">A0039232</p> <p>1 Power supply 10.5 to 30 VDC Ex i 2 Power supply 10.5 to 35 VDC, for other types of protection and non-certified device versions 3 $R_{L,max}$ maximum load resistance U_B Supply voltage</p> <p>i Operation via handheld terminal or PC with operating program: take minimum communication resistance of 250 Ω into consideration.</p>
Damping	<p>A damping affects all outputs (output signal, display). Damping can be enabled as follows: Factory setting: 1 s</p>
Ex connection data	<p>See the separate technical documentation (Safety Instructions (XA)) on www.endress.com/download.</p>
Linearization	<p>The device's linearization function allows the user to convert the measured value to any units of height or volume. User-defined linearization tables of up to 32 value pairs can be entered if necessary.</p>

Protocol-specific data

HART

- Manufacturer ID: 17 (0x11{hex})
- Device type ID: 0x112A
- Device revision: 1
- HART specification: 7
- DD revision: 1
- Device description files (DTM, DD) information and files at:
 - www.endress.com
 - www.fieldcommgroup.org
- HART load: min. 250 Ohm

HART device variables (preset at the factory)

The following measured values are assigned to the device variables at the factory:

Device variable	Measured value
Primary variable (PV) ¹⁾	Pressure ²⁾
Secondary variable (SV)	Sensor temperature
Tertiary variable (TV)	Electronics temperature
Quaternary variable (QV)	Sensor pressure ³⁾

- 1) The PV is always applied to the current output.
- 2) The pressure is the calculated signal after damping and position adjustment.
- 3) The Sensor pressure is the raw signal of the measuring cell before damping and position adjustment.

 The assignment of the measured values to the device variables can be changed in the following submenu:
Application → HART output → HART output

 In a HART Multidrop loop, only one device may use the analog current value for signal transmission. For all other devices in the "**Loop current mode**" parameter, select the **Disable** option.

Choice of HART device variables

- **Pressure** option (after position adjustment and damping)
 - Scaled variable
 - Sensor temperature
 - Sensor pressure
 - Sensor Pressure is the raw signal from sensor before damping and position adjustment.
 - Electronics temperature
 - Percent of range
 - Loop current
 - The loop current is the output current set by the applied pressure.

Supported functions

- Burst mode
- Additional transmitter status
- Device locking

Wireless HART data

- Minimum starting voltage: 10.5 V
- Start-up current: 3.6 mA
- Start-up time: <5 s
- Minimum operating voltage: 10.5 V
- Multidrop current: 4 mA

15.2 Environment

Ambient temperature range

The following values apply up to a process temperature of +85 °C (+185 °F). At higher process temperatures, the permitted ambient temperature is reduced.

- Without segment display or graphic display:
Standard: -40 to +85 °C (-40 to +185 °F)
- With segment display or graphic display: -40 to +85 °C (-40 to +185 °F) with limitations in optical properties such as display speed and contrast. Can be used without limitations up to -20 to +60 °C (-4 to +140 °F)
Segment display: up to -50 to +85 °C (-58 to +185 °F) with restricted operating life and performance
- Devices with PVC-coated capillary armor: -25 to +80 °C (-13 to +176 °F)
- Separate housing: -20 to +60 °C (-4 to +140 °F)

Applications with very high temperatures: use diaphragm seals with a temperature isolator or capillaries. Use a mounting bracket!

If vibrations additionally occur in the application: use a device with a capillary. Diaphragm seal with temperature isolator: use a mounting bracket!

Ambient temperature T_a depending on the process temperature T_p

The process connection must be fully insulated for ambient temperatures below -40 °C (-40 °F).

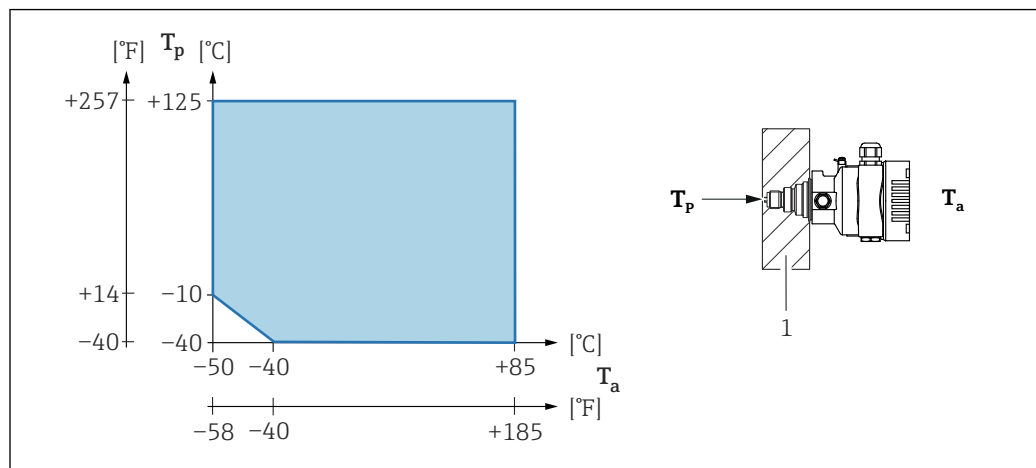

1 Insulation material

Hazardous area

- For devices for use in hazardous areas, see the Safety Instructions, Installation Drawing or Control Drawing
- Devices that have the most common explosion protection certificates (e.g. ATEX/ IEC Ex, etc.) can be used in explosive atmospheres up to the ambient temperature.

Storage temperature

- Without LCD display:
Standard: -40 to +90 °C (-40 to +194 °F)
- With LCD display: -40 to +85 °C (-40 to +185 °F)
- Separate housing: -40 to +60 °C (-40 to +140 °F)

With M12 plug, elbowed: -25 to +85 °C (-13 to +185 °F)

Devices with PVC-coated capillary armor: -25 to +90 °C (-13 to +194 °F)

Operating altitude	Up to 5 000 m (16 404 ft) above sea level.
Climate class	Class 4K4H (air temperature: -20 to +55 °C (-4 to +131 °F), relative humidity: 4 to 100 %) satisfied as per DIN EN 60721-3-4. Condensation is possible.
Atmosphere	Operation in very corrosive environment For corrosive environments (e.g. maritime environment / coastal areas), Endress+Hauser recommends the use of a PVC-coated capillary armor or a PTFE capillary armor for capillaries and the stainless steel housing. The transmitter can be additionally protected by a special coating (Technical Special Product (TSP)).
Degree of protection	Test as per IEC 60529 and NEMA 250-2014

Housing and process connection

IP66/68, TYPE 4X/6P

(IP68: (1.83 mH₂O for 24 h))

Cable entries

- Gland M20, plastic, IP66/68 TYPE 4X/6P
- Gland M20, brass nickel plated, IP66/68 TYPE 4X/6P
- Gland M20, 316L, IP66/68 TYPE 4X/6P
- Thread M20, IP66/68 TYPE 4X/6P
- Thread G1/2, IP66/68 TYPE 4X/6P
If the G1/2 thread is selected, the device is delivered with an M20 thread as standard and a G1/2 adapter is included with the delivery, along with the corresponding documentation
- Thread NPT1/2, IP66/68 TYPE 4X/6P
- Dummy plug transport protection: IP22, TYPE 2
- Plug HAN7D, 90 deg. IP65 NEMA Type 4X
- Plug M12
When housing is closed and connecting cable is plugged in: IP66/67 NEMA Type 4X
When housing is open or connecting cable is not plugged in: IP20, NEMA Type 1

NOTICE

Plug M12 and plug HAN7D: incorrect mounting can invalidate the IP protection class!

- ▶ The degree of protection only applies if the connecting cable used is plugged in and screwed tight.
- ▶ The degree of protection only applies if the connecting cable used is specified according to IP67 NEMA Type 4X.
- ▶ The IP protection classes are only maintained if the dummy cap is used or the cable is connected.

Process connection and process adapter when using the separate housing

FEP cable

- IP69 (on sensor side)
- IP66 TYPE 4/6P
- IP68 (1.83 mH₂O for 24 h) TYPE 4/6P

PE cable

- IP69 (on sensor side)
- IP66 TYPE 4/6P
- IP68 (1.83 mH₂O for 24 h) TYPE 4/6P

Electromagnetic
compatibility (EMC)

- Electromagnetic compatibility as per EN 61326 series and NAMUR recommendation EMC (NE21)
- With regard to the safety function (SIL), the requirements of EN 61326-3-x are satisfied
- Maximum deviation with interference influence: < 0.5% of span with full measuring range (TD 1:1)

For more details refer to the EU Declaration of Conformity.

15.3 Process

Process temperature range **Standard device (without diaphragm seal)**

NOTICE

The permitted process temperature depends on the process connection, process seal, ambient temperature and the type of approval.

- All the temperature data in this document must be taken into consideration when selecting the device.

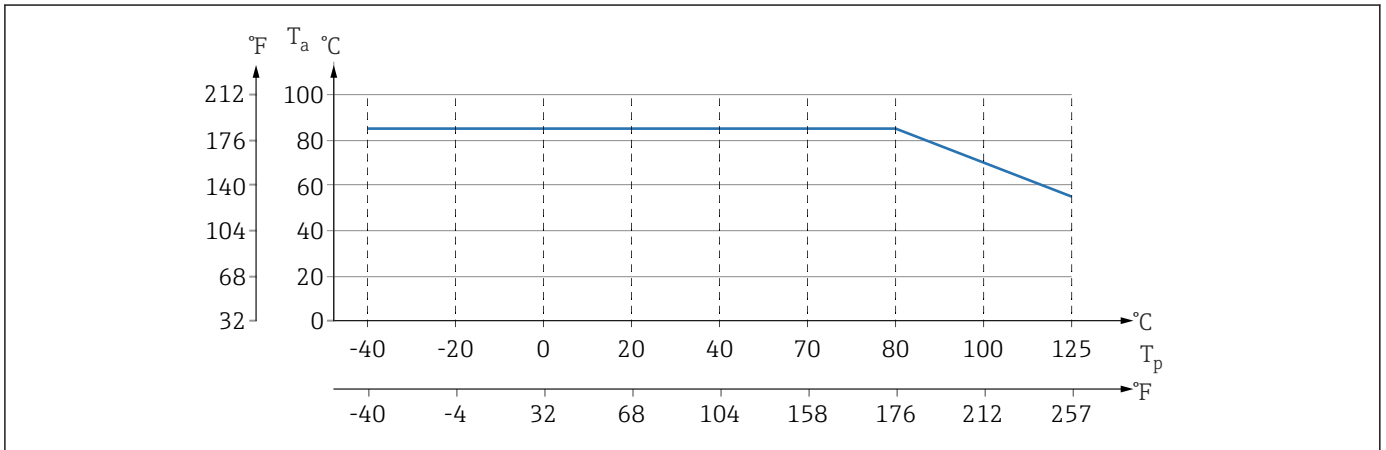

A0043292

10 Values apply for vertical mounting without insulation.

T_p Process temperature

T_a Ambient temperature

Diaphragm seal fill fluid

Fill fluid	$P_{abs} = 0.05 \text{ bar (0.725 psi)}^1$	$P_{abs} \geq 1 \text{ bar (14.5 psi)}^2$
Silicone oil	-40 to +180 °C (-40 to +356 °F)	-40 to +250 °C (-40 to +482 °F)
High-temperature oil	-20 to +200 °C (-4 to +392 °F)	-20 to +400 °C (-4 to +752 °F) ^{3) 4) 5)}
Low-temperature oil	-70 to +120 °C (-94 to +248 °F)	-70 to +180 °C (-94 to +356 °F)
Vegetable oil	-10 to +160 °C (+14 to +320 °F)	-10 to +220 °C (+14 to +428 °F)
Inert oil	-40 to +100 °C (-40 to +212 °F)	-40 to +175 °C (-40 to +347 °F) ^{6) 7)}

- 1) Permitted temperature range at $p_{abs} = 0.05 \text{ bar (0.725 psi)}$ (observe temperature limits of the device and the system!)
- 2) Permitted temperature range at $p_{abs} \geq 1 \text{ bar (14.5 psi)}$ (observe temperature limits of the device and the system!)
- 3) 325 °C (617 °F) at $\geq 1 \text{ bar (14.5 psi)}$ absolute pressure
- 4) 350 °C (662 °F) at $\geq 1 \text{ bar (14.5 psi)}$ absolute pressure (max. 200 hours)
- 5) 400 °C (752 °F) at $\geq 1 \text{ bar (14.5 psi)}$ absolute pressure (max. 10 hours)
- 6) 150 °C (302 °F) at $\geq 1 \text{ bar (14.5 psi)}$ absolute pressure
- 7) 175 °C (347 °F) at $\geq 1 \text{ bar (14.5 psi)}$ absolute pressure (max. 200 hours)

Fill fluid	Density ¹⁾ kg/m ³
Silicone oil	970
High-temperature oil	995
Low-temperature oil	940

Fill fluid	Density ¹⁾ kg/m ³
Vegetable oil	920
Inert oil	1900

1) Density of the diaphragm seal fill fluid at 20 °C (68 °F).

The calculation of the operating temperature range of a diaphragm seal system depends on the fill fluid, capillary length and capillary internal diameter, process temperature and oil volume of the diaphragm seal. Detailed calculations, e.g. for temperature ranges, negative pressure and temperature ranges, are done separately in the Applicator "[Sizing Diaphragm Seal](#)".



A0038925

Oxygen applications (gaseous)

Oxygen and other gases can react explosively to oils, grease and plastics. The following precautions must be taken:

- All components of the system, such as devices, must be cleaned in accordance with national requirements.
- Depending on the materials used, a certain maximum temperature and a maximum pressure must not be exceeded for oxygen applications.

The cleaning of the device (not accessories) is provided as an optional service.

- p_{max} : Depends on the lowest-rated element, with regard to pressure, of the selected components: Over pressure limit (OPL) of the measuring cell, process connection (1.5 x PN) or fill fluid (80 bar (1 200 psi))
- T_{max} : 60 °C (140 °F)

Standard device (without diaphragm seal)

- Process connections with internal membrane: -40 to +125 °C (-40 to +257 °F) ; 150 °C (302 °F) for max. one hour)
- Process connections with flush membrane:
 - Thread (ISO228, ASME, metric DIN13) and flanges (EN, ASME, JIS): -40 to +100 °C (-40 to +212 °F)
 - Exceptions with seal supplied (M20 x 1.5, G1/2 DIN3852): -20 to +85 °C (-4 to +185 °F)

Devices with diaphragm seal

- Depends on diaphragm seal and fill fluid: -70 °C (-94 °F) up to +400 °C (+752 °F)
- Observe the maximum gauge pressure and maximum temperature

Diaphragm seal with tantalum membrane

-70 to +300 °C (-94 to +572 °F)

Devices with PTFE-coated diaphragm seal membrane

The anti-stick coating has very good anti-friction properties and protects the membrane against abrasive media.

NOTICE

Destruction of the device due to incorrect use of PTFE coating!

- ▶ The PTFE coating used is designed to protect the unit against abrasion. It does not provide protection against corrosive media.

Area of application of the 0.25 mm (0.01 in) PTFE foil on AISI 316L (1.4404/1.4435) membrane, see the following graphic:

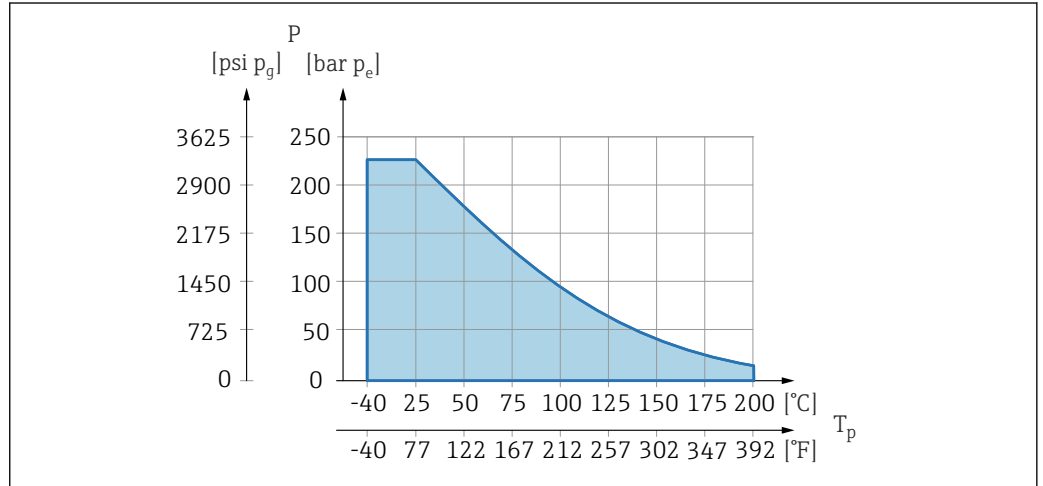

A0045213

i For vacuum applications: $p_{abs} \leq 1 \text{ bar (14.5 psi)}$ to $0.05 \text{ bar (0.725 psi)}$ to max. $+150 \text{ °C (302 °F)}$.

If a PTFE coating has been selected, a conventional membrane is always delivered.

Diaphragm seal capillary armor

Process temperature depending on the ambient temperature.

- 316L: No restrictions
- PTFE: No restrictions
- PVC: See the following diagram

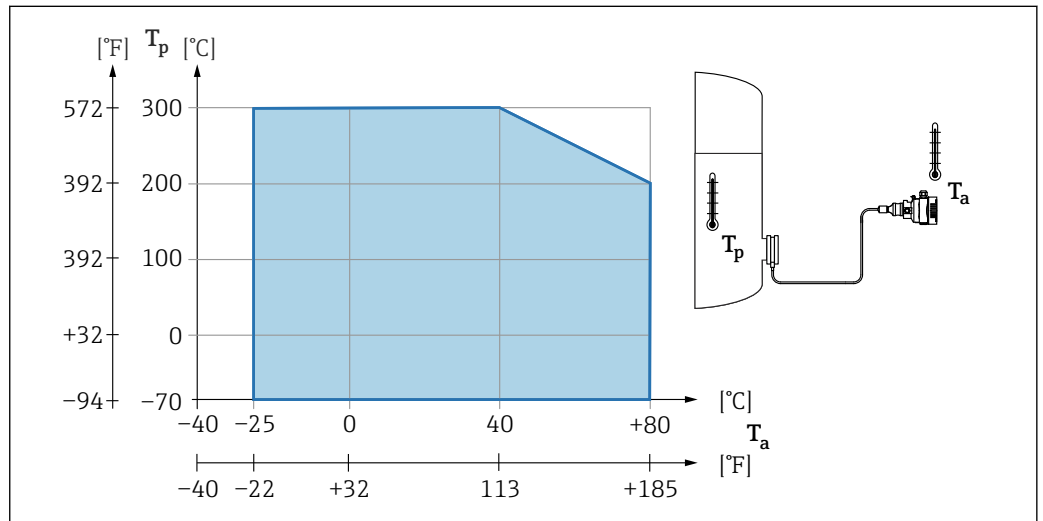

A0038681

Process pressure range

Pressure specifications

⚠ WARNING

The maximum pressure for the device depends on the lowest-rated component with regard to pressure (components are: process connection, optional mounted parts or accessories).

- ▶ Only operate the device within the specified limits for the components!
- ▶ MWP (maximum working pressure): The MWP is specified on the nameplate. This value refers to a reference temperature of +20 °C (+68 °F) and may be applied to the device for an unlimited time. Note temperature dependence of MWP. For flanges, refer to the following standards for the permitted pressure values at higher temperatures: EN 1092-1 (with regard to their stability/temperature property, the materials 1.4435 and 1.4404 are grouped together under EN 1092-1; the chemical composition of the two materials can be identical.), ASME B 16.5a, JIS B 2220 (the latest version of the standard applies in each case). MWP data that deviate from this are provided in the relevant sections of the Technical Information.
- ▶ The overpressure limit is the maximum pressure a device may be subjected to during a test. It is greater than the maximum working pressure by a certain factor. This value refers to a reference temperature of +20 °C (+68 °F).
- ▶ The Pressure Equipment Directive (2014/68/EU) uses the abbreviation "PS". The abbreviation "PS" corresponds to the MWP (maximum working pressure) of the device.
- ▶ In the case of measuring cell range and process connection combinations where the overpressure limit (OPL) of the process connection is smaller than the nominal value of the measuring cell, the device is set at the factory, at the very maximum, to the OPL value of the process connection. If the entire measuring cell range must be used, select a process connection with a higher OPL value (1.5 x PN; MWP = PN).
- ▶ Oxygen applications: do not exceed values for P_{max} and T_{max} .

Burst pressure

As of the specified burst pressure, the complete destruction of the pressure-bearing parts and/or a device leak must be expected. It is therefore imperative to avoid such operating conditions by carefully planning and sizing your facility.

Ultrapure gas applications

Endress+Hauser also offers devices for special applications, such as for ultrapure gas, that are cleaned of oil and grease. No special restrictions regarding the process conditions apply to these devices.

Hydrogen applications

A **gold-coated** metallic membrane offers universal protection against hydrogen diffusion, both in gas applications and in applications with water-based solutions.

Steam applications and saturated steam applications

For steam and saturated steam applications: Use a device with a metallic membrane or provide a water pocket pipe for temperature decoupling when installing.

Thermal insulation

Thermal insulation with diaphragm seal directly mounted

The device may only be insulated up to a certain height. The maximum permitted insulation height is indicated on the device and applies to an insulation material with a heat conductivity $\leq 0.04 \text{ W}/(\text{m} \times \text{K})$ and to the maximum permitted ambient and process temperature. The data were determined under the most critical application "quiescent air". Maximum permitted insulation height, indicated here on a device with a flange:

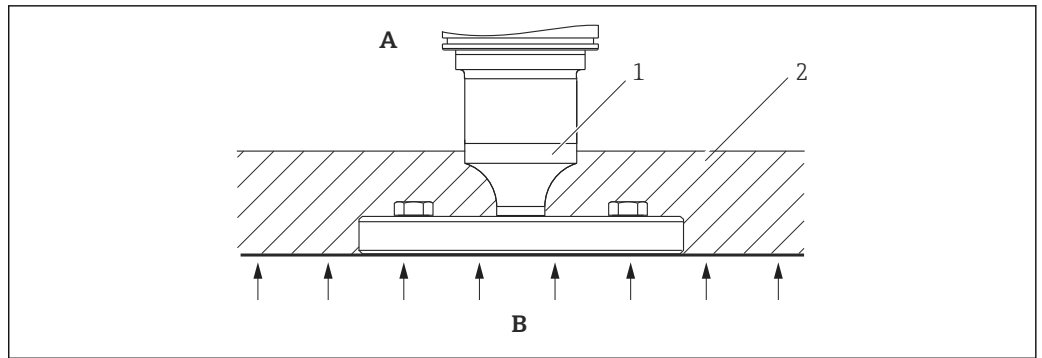

A0020474

- A Ambient temperature
- B Process temperature
- 1 Maximum permitted insulation height
- 2 Insulation material

Mounting with a "Compact" diaphragm seal type

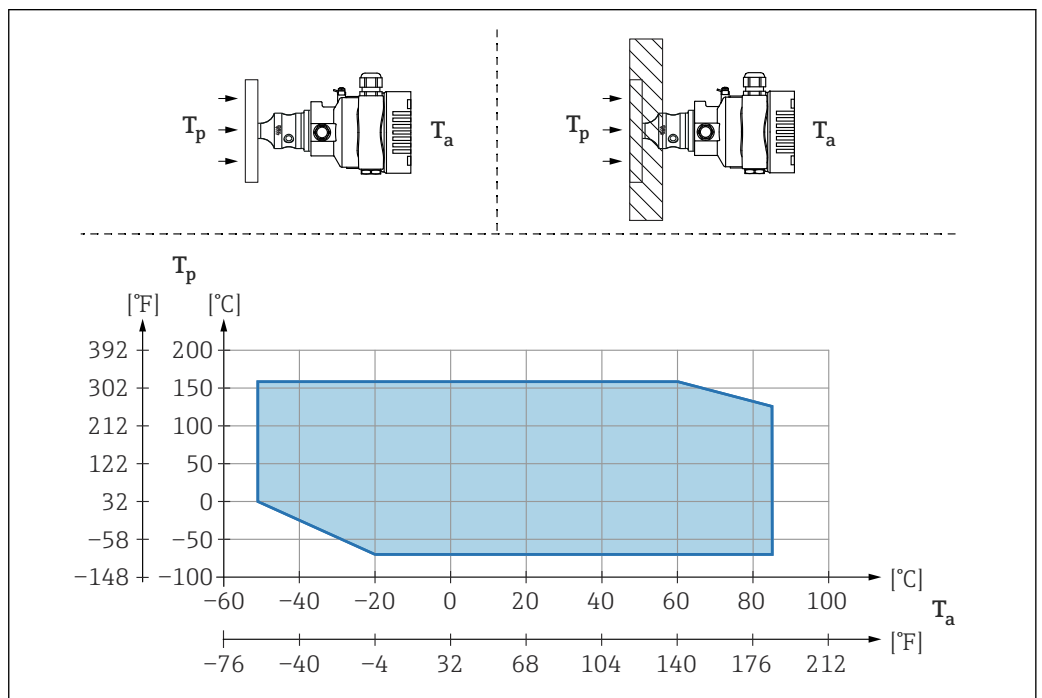

A0040383

- T_a Ambient temperature at transmitter
- T_p Maximum process temperature

T_a	T_p
+85 °C (+185 °F)	-70 to +120 °C (-94 to +248 °F)
+60 °C (+140 °F)	-70 to +160 °C (-94 to +320 °F)
-20 °C (-4 °F)	-70 to +160 °C (-94 to +320 °F)
-50 °C (-58 °F)	0 to +160 °C (+32 to +320 °F)

Thermal insulation when mounting with a "Temperature isolator" diaphragm seal type

Use of temperature isolators in the event of constant extreme medium temperatures which cause the maximum permissible electronics temperature of +85 °C (+185 °F) to be exceeded. Diaphragm seal systems with temperature isolators can be used up to a

maximum temperature of +400 °C (+752 °F) depending on the fill fluid used. For details, see the Technical Information. To minimize the influence of rising heat, mount the device horizontally or with the housing pointing downwards. The additional installation height brings about a zero point shift due to the hydrostatic column in the temperature isolator. This zero point shift can be corrected on the device.

The maximum ambient temperature T_a at the transmitter depends on the maximum process temperature T_p .

The maximum process temperature depends on the fill fluid used.

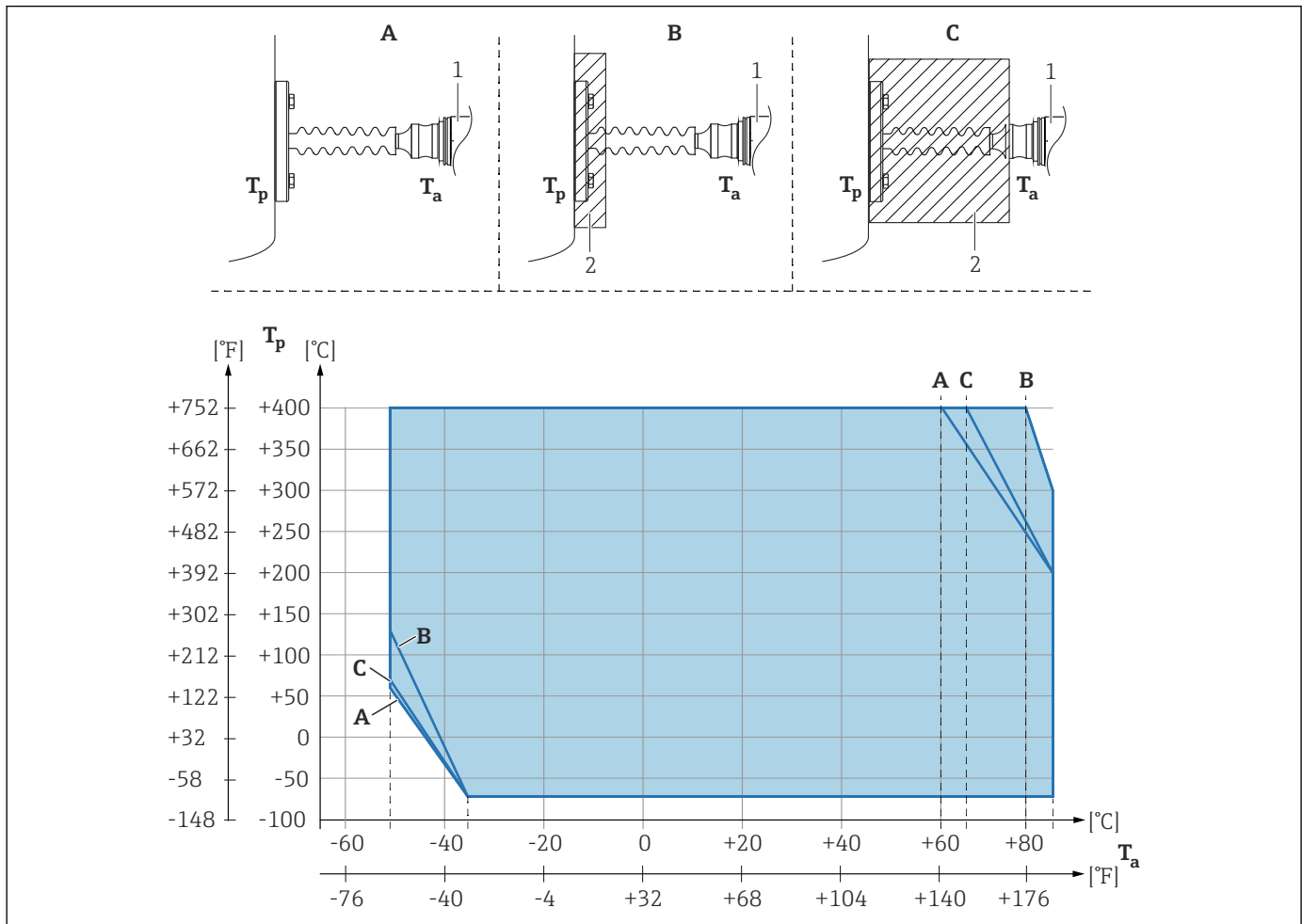

A0039378

- A No insulation
- B Insulation 30 mm (1.18 in)
- C Maximum insulation
- 1 Transmitter
- 2 Insulation material

Item	T_a ¹⁾	T_p ²⁾
A	60 °C (140 °F)	400 °C (752 °F) ³⁾
	85 °C (185 °F)	200 °C (392 °F)
	-50 °C (-58 °F)	60 °C (140 °F)
	-35 °C (-31 °F)	-70 °C (-94 °F)
B	80 °C (176 °F)	400 °C (752 °F) ³⁾
	85 °C (185 °F)	300 °C (572 °F)
	-50 °C (-58 °F)	130 °C (266 °F)
	-35 °C (-31 °F)	-70 °C (-94 °F)

Item	T _a ¹⁾	T _p ²⁾
C	67 °C (153 °F)	400 °C (752 °F) ³⁾
	85 °C (185 °F)	200 °C (392 °F)
	-50 °C (-58 °F)	70 °C (158 °F)
	-35 °C (-31 °F)	-70 °C (-94 °F)

- 1) Maximum ambient temperature at transmitter
- 2) Maximum process temperature
- 3) Process temperature: max. +400 °C (+752 °F), depending on the fill fluid used

Index

A

Access authorization to parameters	
Read access	32
Write access	32
Access code	32
Incorrect input	32

B

Bluetooth® wireless technology	33
--	----

C

CE mark (Declaration of Conformity)	10
Cleaning	62

D

DD	36
Declaration of Conformity	10
Device description files	36
Device documentation	
Supplementary documentation	8
Device locking, status	47
Device usage	
see Intended use	
Device Viewer	63
DeviceCare	35
Diagnosis	
Symbols	53
Diagnostic event	
In the operating tool	54
Diagnostic events	53
Diagnostic list	54
Diagnostic message	53
Display values	
For locking status	47
Disposal	64

E

Event history	57
Events list	57
Exterior cleaning	62

F

FieldCare	34
Function	34
Filtering the event logbook	57
FV (HART variable)	36

H

HART integration	36
HART protocol	39
HART variables	36

I

Intended use	9
------------------------	---

L

Local display	
see Diagnostic message	
see In alarm condition	

M

Maintenance	62
-----------------------	----

N

Nameplate	15
---------------------	----

O

Operation	47
Operational safety	9

P

Product safety	10
PV (HART variable)	36

R

Read access	32
Reading off measured values	47
Repair concept	63
Requirements concerning the staff	9

S

Safety Instructions	
Basic	9
Service interface (CDI)	34, 39
Settings	
Adapting the device to process conditions	47
Spare parts	63
Nameplate	63
Status signals	53
Submenu	
Events list	57
Measured values	47
SV (HART variable)	36

T

Troubleshooting	49
Turning the display module	24
TV (HART variable)	36

U

Using the devices	
Borderline cases	9
Incorrect use	9

W

Workplace safety	9
Write access	32



71695924

www.addresses.endress.com
