

Installation Instructions

HistoROM

Gammapilot, Liquiphant, Micropilot, Prothermo
Cerabar, Deltabar, Prowirl L



1 Intended use

- A defective unit can only be replaced with a functioning unit of the same type.
- Use only original parts from Endress+Hauser.
- In the W@M Device Viewer, check if the spare part is suitable for the existing device.

 In some devices, an overview of spare parts is provided inside the device. If the spare part set is listed in the overview, it is not necessary to check the Device Viewer.

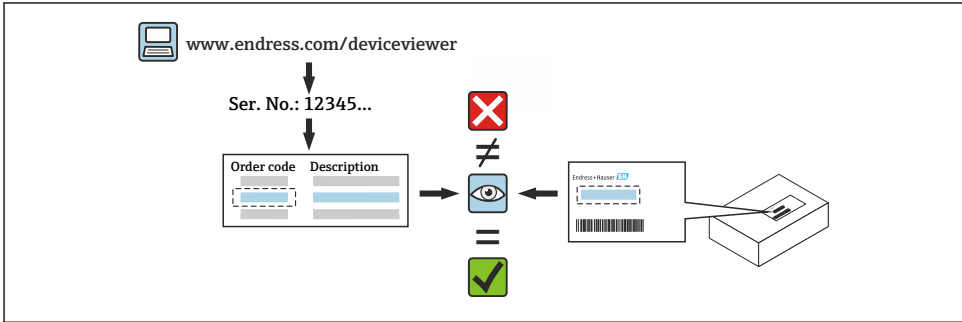

2 Personnel authorized to carry out repairs

Technical staff must comply with the following requirements for repair, mounting, electrical installation and commissioning of the devices:

- Be trained in instrument safety.
- Be familiar with the individual operating conditions of the devices.
- In the case of Ex-certified devices, they must also be trained in explosion protection.

 Technical staff carrying out work are responsible for ensuring that the work is carried out safely and to the required quality standard. They must also guarantee the safety of the device following repair.

3 Safety instructions

- Observe the Operating Instructions for the device.
- Comply with national regulations regarding mounting, electrical installation, commissioning, maintenance and repair.
- Device is live! Risk of fatal injury from electric shock. Open the device only when the device is deenergized.
- For devices intended for use in hazardous locations, please observe the instructions in the Ex documentation (XA).
- In the case of devices in safety-related applications in accordance with IEC 61508 or IEC 61511: Commission in accordance with Operating Instructions after repair.

- Before removing the device: set the process to a safe state and purge the pipe of dangerous process substances.
- Risk of burns from hot surfaces! Before commencing work: allow the system and device to cool down to a touchable temperature.
- In the case of devices in custody transfer, the custody transfer status no longer applies once the seal has been removed.
- Risk of damaging electronic components! Ensure that the working environment is protected against electrostatic discharge.
- After removing the electronics compartment cover: risk of electric shock due to removal of contact protection! Switch the device off before removing internal covers.
- Modifications to the device are not permitted.
- Only open the housing for a short period. Avoid ingress of foreign bodies, moisture or contaminants.
- Replace defective seals only with original seals from Endress+Hauser.
- If threads are damaged or defective, the device must be repaired.
- Do not lubricate threads (e.g. of electronics compartment cover and connection compartment cover).
- If spacing is reduced or the dielectric strength of the device cannot be guaranteed during repair work: Perform a test on completion of the work (e.g. high-voltage test in accordance with the manufacturer's specifications).
- Service connector:
 - Do not connect in potentially explosive atmospheres.
 - Only connect to Endress+Hauser service devices.
- Observe the instructions for transporting and returning the device outlined in the Operating Instructions.

 For information on service and spare parts, contact your Endress+Hauser sales center.

4 Tool list

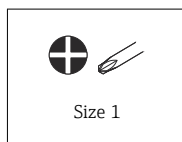
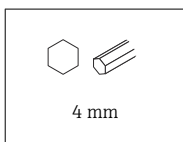

5 Housing version

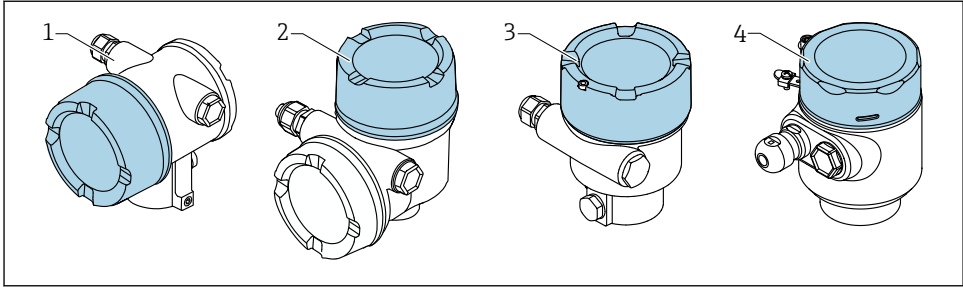

- 1 Dual-compartment housing
- 2 Dual compartment housing, L-form
- 3 Single-compartment housing
- 4 Single-compartment housing, 316L hygiene

6 Removal

6.1 Single-compartment housing and dual-compartment housing, L-form

6.1.1 Removing the cover

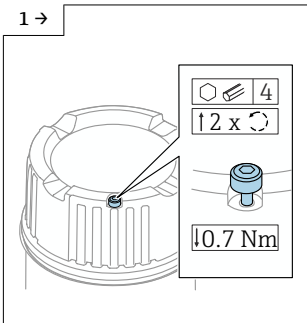

► Optional: cover lock

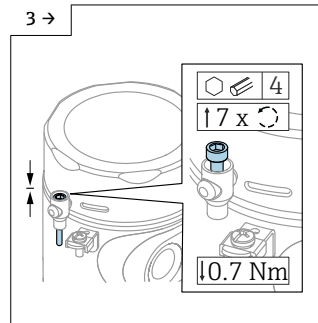
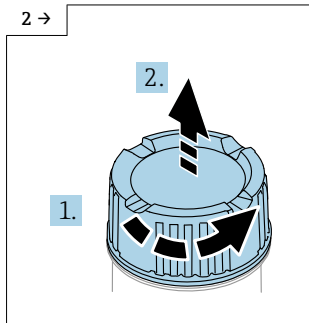

► Optional: cover lock on single-compartment housing, 316L hygiene

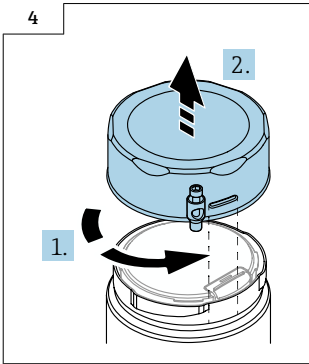

6.1.2 Optional: removing the display

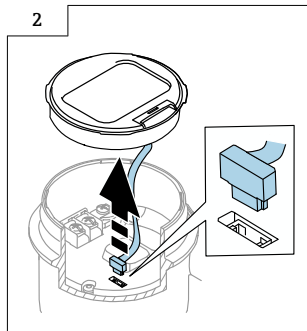
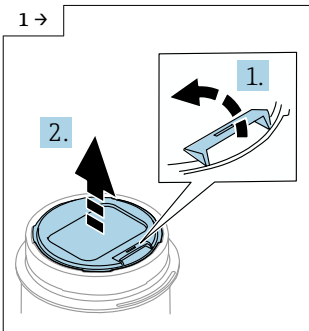

6.1.3 Optional: removing the transmitter VU140

- For customer wiring: step 1, 2, 3
- For M12: step 2, 3

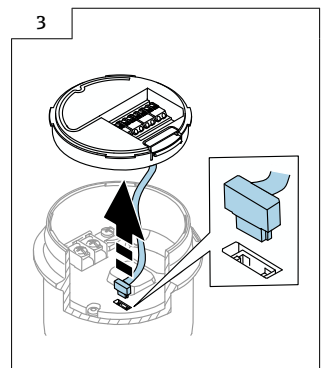
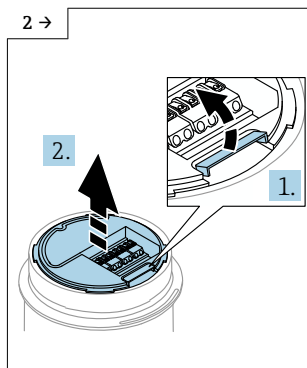
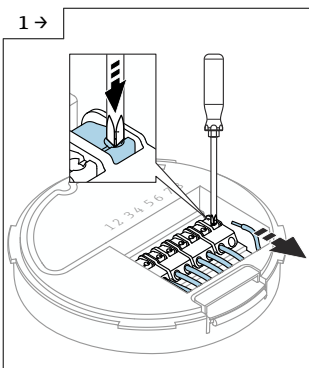

6.1.4 Removing the HistoROM module

- Single-compartment housing: step 1, 2, 4, 5, 6
- Dual-compartment housing, L-form: step 3, 4, 5, 6

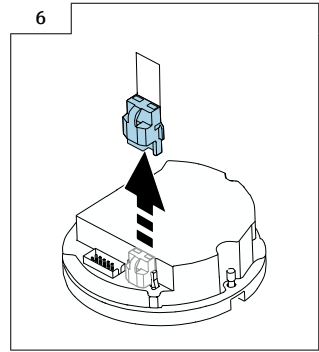
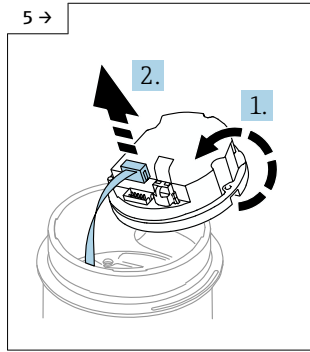
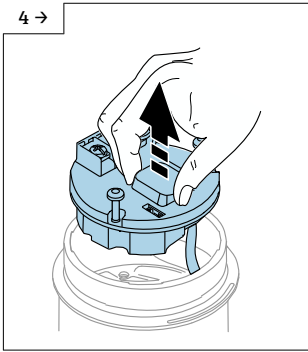
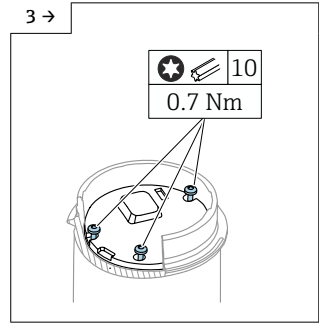
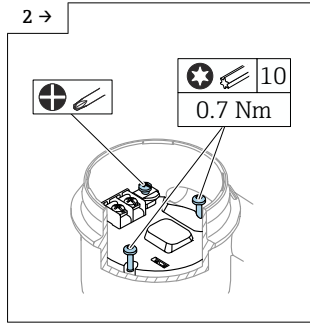
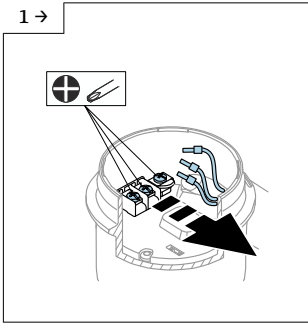

6.1.5 HistoROM Liquiphant

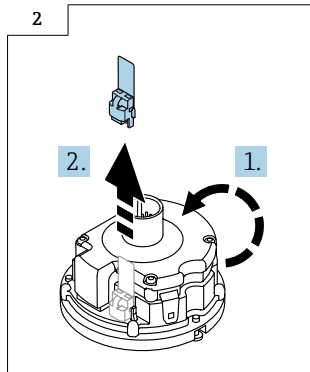
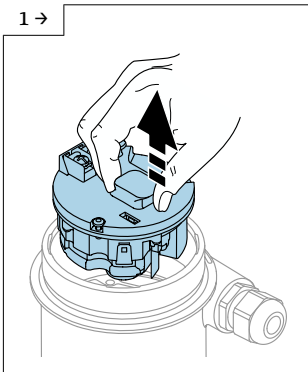

6.2 Dual-compartment housing (not L-form)

6.2.1 Removing the cover

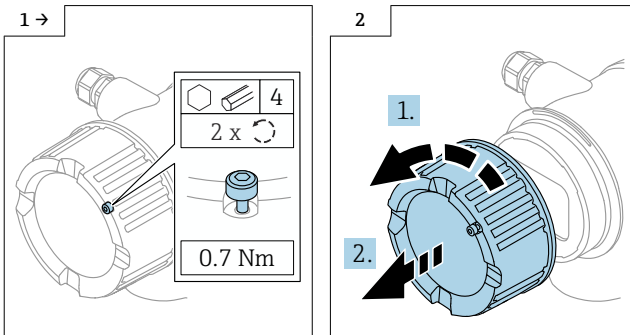

► Optional: cover lock

6.2.2 Optional: removing the display

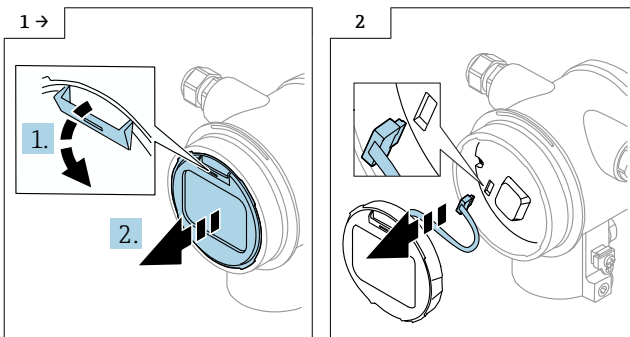

6.2.3 Removing the HistoROM module

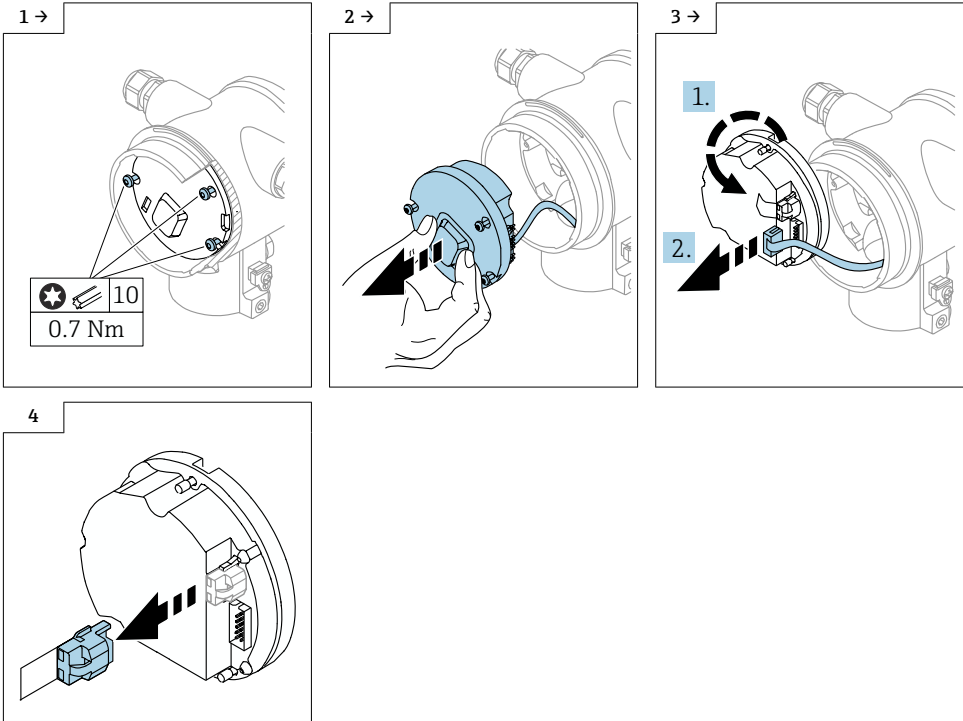

7 Installation

7.1 General installation instructions

Installation is performed by following the removal procedure in reverse order.

7.2 Special installation instructions

7.2.1 Mounting the HistoRom module

i Only for Liquiphant: Insert the electronics module as far as it will go into the housing in the position shown.

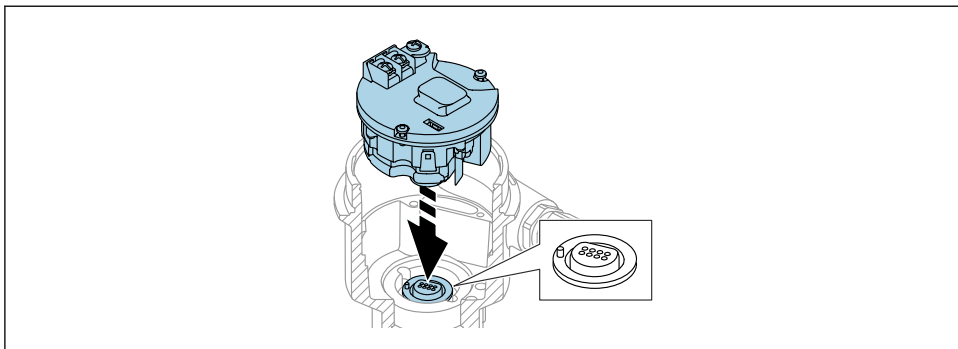

7.2.2 For remote display FHX50B: pay attention to terminal assignment

The terminal assignments at transmitter VU140 and receiver VU141 must match (all terminals (1 to 8)). Connect the cable shield to the ground terminals on both sides.

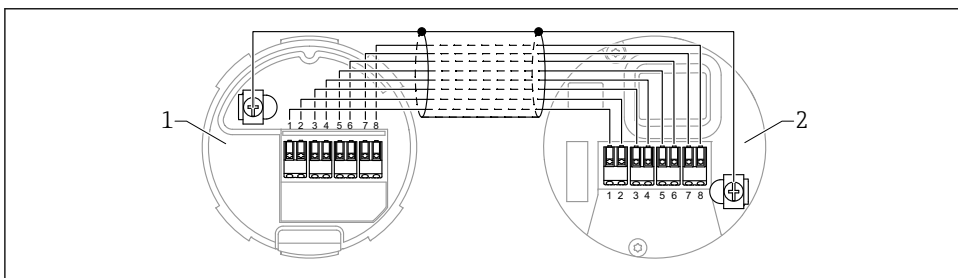

- 1 Transmitter VU140
- 2 Receiver VU141

7.2.3 Cover lock

In the case of devices with a cover lock, the securing screw must not protrude over the lower edge of the cover. Note the position of the securing screw before and while screwing the cover on.

8 Putting the device into operation

The device configuration at the time of delivery can be restored via the File parameter (Asset Central Viewer). The HistoROM Recovery Tool from Endress+Hauser Service must be used for this purpose.

9 Disposal

 If required by the Directive 2012/19/EU on waste electrical and electronic equipment (WEEE), the product is marked with the depicted symbol in order to minimize the disposal of WEEE as unsorted municipal waste. Do not dispose of products bearing this marking as unsorted municipal waste. Instead, return them to the manufacturer for disposal under the applicable conditions.



71697119

www.addresses.endress.com
