

Technical Information

Solitrend MMP42

Material moisture measurement

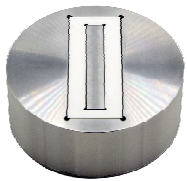

Flexible in-line moisture measurement, suitable for low-density bulk solids

Application

Moisture measurement in bulk solids with low density from 0.3 to 1 g/cm³ (0.011 to 0.036 lb/in³) e.g. animal feed, grain, plastic granules and pellets

Your benefits

- Easy commissioning even in challenging processes
- Deep material penetration
- Measuring range 0 to 100 % vol. water content
- Various installation accessories available
- Optional high-temperature version up to 120 °C (248 °F) thanks to remote electronics module
- Integrated transmitter for simple system integration
- Measurement of surface and capillary moisture

Table of contents

About this document	3	Accessories	18
Symbols	3	Device-specific accessories	18
Function and system design	3	Documentation	19
Measuring principle	3	Brief Operating Instructions (KA)	19
Calibration	4	Operating Instructions (BA)	19
Operating mode	4	Safety Instructions (XA)	19
Communication	4		
Input	4		
Measured variable	4		
Measuring range	4		
Output	5		
Analog	5		
Digital	5		
Linearization	5		
Power supply	5		
Terminal assignment	5		
Supply voltage	5		
Power consumption	5		
Power supply failure	5		
Electrical connection	6		
Potential equalization	6		
Cable specification	6		
Performance characteristics	7		
Reference operating conditions	7		
Measured value resolution	7		
Mounting	7		
Mounting location	7		
Installation instructions	7		
Special mounting instructions	12		
Environment	12		
Ambient temperature range	12		
Storage temperature	12		
Operating altitude	12		
Degree of protection	12		
Process	12		
Process temperature range	12		
Mechanical construction	13		
Design	13		
Dimensions	14		
Weight	16		
Materials	16		
Certificates and approvals	17		
Ordering information	18		

About this document

Symbols

Safety symbols

DANGER

This symbol alerts you to a dangerous situation. Failure to avoid this situation will result in serious or fatal injury.

WARNING

This symbol alerts you to a dangerous situation. Failure to avoid this situation can result in serious or fatal injury.

CAUTION

This symbol alerts you to a dangerous situation. Failure to avoid this situation can result in minor or medium injury.

NOTICE

This symbol contains information on procedures and other facts which do not result in personal injury.

Symbols for certain types of information and graphics

Tip

Indicates additional information



Reference to graphic

Symbols in graphics

1, 2, 3, ...

Item numbers

A, B, C, ...

Views

Function and system design

Measuring principle

Time-domain reflectometry (TDR) is a radar-based dielectric measurement method where the transit time of electromagnetic pulses is determined to measure the dielectric constant, and therefore the water content. The devices consist of a stainless steel housing with a ceramic window. A transmitter is integrated in the housing. The high-frequency TDR pulse generated in the transmitter runs along a wave guide and generates an electromagnetic field around this conductor and therefore in the material on the measurement surface. Using a patented measurement method, the transit time of this pulse is measured with a resolution of one picosecond (1×10^{-12}) in order to determine the moisture and conductivity.

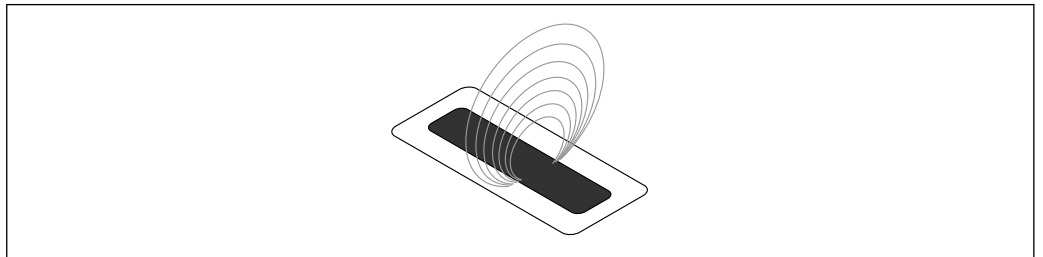

 1 Wave guide; continuous, wide

A0040293

The TDR method operates in the ideal frequency range between 600 MHz and 1.2 GHz.

The modular TDR technology enables moisture measurement in special applications, particularly in materials with a high conductivity, and can be adapted to individual applications due to the variable device design and accessories.

Calibration	The device is delivered with an appropriate calibration to suit the measuring task. A maximum of 15 different calibrations can be saved in the device and can be activated and adjusted via the remote display.
Operating mode	<p>The sensor is supplied from the factory with the CA mode for general process applications. 6 different operating modes are available in the C measuring mode, depending on the application.</p> <ul style="list-style-type: none"> ▪ CS mode (Cyclic-Successive) For very short measurement cycles in the seconds range (e.g. 1 to 10 s) without averaging and without filter functions, and with up to 100 measurements per second internally and a cycle time of 250 ms at the analog output. ▪ CA mode (Cyclic Average Filter) Standard averaging for relatively fast but continuous measurement processes, with simple filtering and an accuracy of up to 0.1 %. The CA operating mode is also used to record raw values, without averaging and filtering, to be able to subsequently analyze the measured data and determine the optimum operating mode. ▪ CF mode (Cyclic Floating Average with Filter) Floating average for very slow and continuous measurement processes, with simple filtering and an accuracy of up to 0.1 %. Suitable for applications on a conveyor belt etc. ▪ CK mode (Cyclic with Boost Filter) For complex applications in mixers and dryers ▪ CC mode (Cyclic Cumulated) With automatic totalization of moisture quantity measurements in one batch process if no PLC controller is used ▪ CH mode (Cyclic Hold) Standard operating mode for applications in the construction industry. Similar to the CC mode, but with filtering and without totalization. The CH mode is ideal for very short batch times down to 2 s if the sensor has been installed under the silo discharge hatch. The CH mode performs filtering automatically. This allows drip water that forms in the silo to be filtered out of the measured value, for example.
Communication	The serial interface enables network operation of the device. A data bus protocol for the connection of multiple devices is implemented by default.

Input

Measured variable	<ul style="list-style-type: none"> ▪ Channel 1 Material moisture in % (variable setting) ▪ Channel 2 Conductivity 0 to 2 mS/cm or (optionally) temperature 0 to 100 °C (32 to 212 °F), this also applies for the high-temperature version.
Measuring range	<ul style="list-style-type: none"> ▪ Material moisture The material moisture can be determined with a water content ranging from 0 to 100 % vol. ▪ Temperature sensor The temperature can be determined in the range from 0 to 100 °C (32 to 212 °F), this also applies for the high-temperature version. ▪ Material conductivity Material conductivity can be determined up to a maximum value of 2 mS/cm

Output

Analog

- Channel 1 (material moisture):
0 to 20 mA/ 4 to 20 mA
- Channel 2 (material conductivity or material temperature):
0 to 20 mA/4 to 20 mA



The analog outputs can be set differently to the following possible options:

Moisture, temperature

Analog output 1 for moisture, output 2 for material temperature.

Moisture, conductivity

Analog output 1 for moisture, output 2 for conductivity of 0 to 20 mS/cm (factory setting)

Moisture, temperature/conductivity

Analog output 1 for moisture, output 2 for material temperature and conductivity with automatic window changeover.

Starting time

The first stable measured value is present at the analog output after approx. 1 s.

Digital

- Serial interface, RS485 standard
- IMP-Bus
 - Signal cable and operating voltage are galvanically isolated
 - Data transmission rate 9 600 Bit/s

Linearization

15 different calibration curves can be selected and saved via the remote display (optional).

Customer-specific calibrations can also be created and saved via the display.

Power supply

Terminal assignment

- **Round sensor:** normally supplied with a 10-pin MIL plug.
- **Rectangular sensor:** normally supplied with a 5 m (16.4 ft) long, 10-pin cable with wire end ferrules.

Supply voltage

12 to 24 V_{DC}



Overvoltage

- ▶ Only use stabilized power units

Power consumption

<3 W

Power supply failure

The configuration is retained in the device.

Electrical connection

Connection example of 10-pin socket

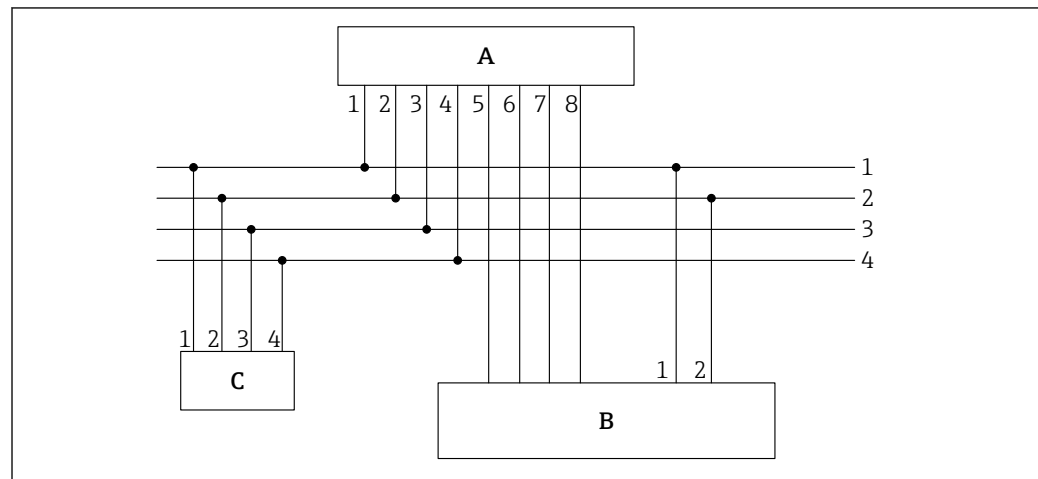

A0037418

2 Connection example, cable with 10-pin socket (on device side) and wire end ferrules at the cable end

- A Transmitter
 B PLC/distribution box
 C Remote display (optional)
- 1 0 V_{DC} power supply
 Wire color: blue (BU)
- 2 12 to 24 V_{DC} stabilized power supply
 Wire color: red (RD)
- 3 IMP-Bus RT
 Wire color: gray (GY)/pink (PK)
- 4 IMP-Bus COM
 Wire color: blue (BU)/red (RD)
- 5 1st current output (+), analog
 Wire color: green (GN)
- 6 1st current output (-), analog
 Wire color: yellow (YE)
- 7 2nd current output (+), analog
 Wire color: pink (PK)
- 8 2nd current output (-), analog
 Wire color: gray (GY)

i The moisture content determined and the conductivity/temperature can either be fed directly into a PLC via analog outputs 0 to 20 mA/4 to 20 mA or queried via the serial interface (IMP-Bus) using the display (optional).

Potential equalization

The shield is grounded at the device.

Cable specification

Connecting cables are available in different versions and lengths (depending on sensor design).

Round sensor

Connecting cables with a preassembled 10-pin socket on the sensor side are available in different standard lengths:

- 4 m (13 ft)
- 10 m (32 ft)
- 25 m (82 ft)

UNITRONIC PUR CP shielded cable, twisted pairs $6 \times 2 \times 0.25 \text{ mm}^2$, PUR sheath resistant to oils and chemicals.

Rectangular sensor

Standard lengths (fixed cable):

- 5 m (16 ft)
- Cable lengths of 1 to 100 m (3 to 328 ft) are possible upon request

UNITRONIC PUR CP shielded cable, $10 \times 0.25 \text{ mm}^2$, PUR sheath resistant to oils and chemicals.

Performance characteristics

Reference operating conditions

The following reference conditions apply to the performance characteristics:

- Ambient temperature: 24 °C (75 °F) ±5 °C (±9 °F)
- Ideal installation conditions:
 - Constant bulk density
 - Sufficient material volume flow through the measuring field
 - No buildup

Measured value resolution

Material moisture

Measuring range up to 100 % vol.

Conductivity

- The device delivers a characteristic value depending on the mineral concentration
- In material moisture measurement ranges > 50 %, the conductivity range in which a stable measurement can be performed is reduced
- The conductivity value determined is uncalibrated and is primarily used to characterize the material being measured

Temperature

Measuring range: 0 to 100 °C (32 to 212 °F)

The temperature is measured 3 mm below the sensor surface in the housing and can be output at analog output 2. Due to the internal heating of the electronics, the precise measurement of the material temperature is only possible to a limited extent. The material temperature can be determined following an external calibration and compensation of the sensor's internal heating.

Maximum measured error

Accuracy up to ±0.3 %_{abs} under ideal, constant installation and material conditions.

The measured error depends on the operating mode and on the flow of material over the sensor surface. The longer the averaging time and the more stable the material density in the measurement volume over the sensor, the lower the measured error.

Mounting

Mounting location

- The device must be installed at a point in the process in such a way that ensures a constant bulk density, as the bulk density directly affects the calculation of the water content. Where necessary, a bypass should be created or structural measures may be needed at the place of installation to ensure that the material flow, and therefore the bulk density, over the measurement surface is constant.
- The measuring field of the device must be completely covered by material and the material height must exceed the minimum layer of material covering on the measurement surface (depends on the device type and moisture).
- The flow of material over the measurement surface must be continuous. With the software, it is possible to automatically detect and bridge gaps in material flow in intervals of seconds.
- No material deposits or buildup may form on the measuring cell surface, as this would falsify the readings.



Longer averaging times increase the stability of the measured value.

Installation instructions

Round sensor, short / middle

The round sensor, short / middle version, can be mounted with a mounting flange.

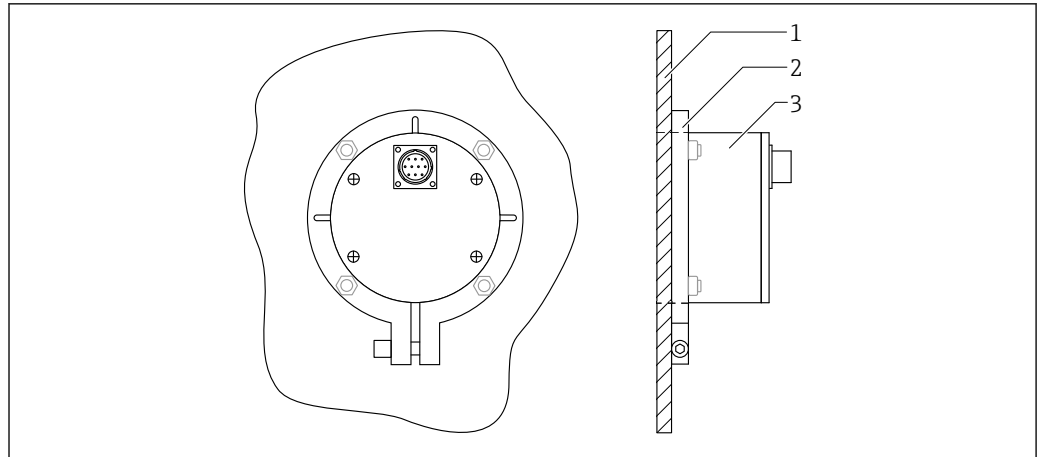

A0037422

3 Round sensor mounted, rear view

- 1 Vessel wall
- 2 Mounting flange
- 3 Round sensor, short / middle

Rectangular sensor

The rectangular sensor can be installed with four screws (M8).

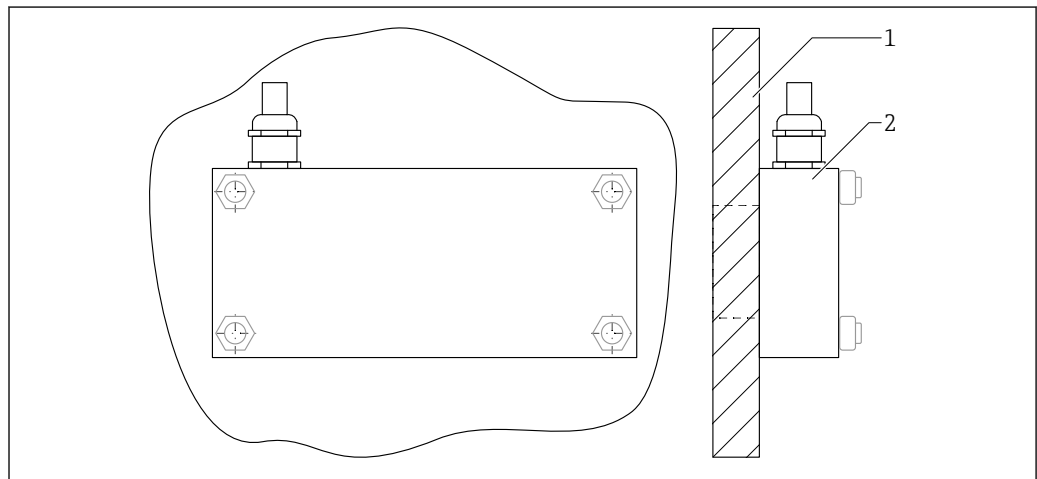

A0047262

4 Rectangular sensor mounted, rear view

- 1 Vessel wall
- 2 Rectangular sensor

Installing the round sensor for moisture measurement in bulk solids

The installation conditions depend greatly on the specific plant conditions. The optimum mounting location must be determined individually on a case-by-case basis. Ideally, the round sensor for the measurement of cereal or animal feed is installed under the silo.

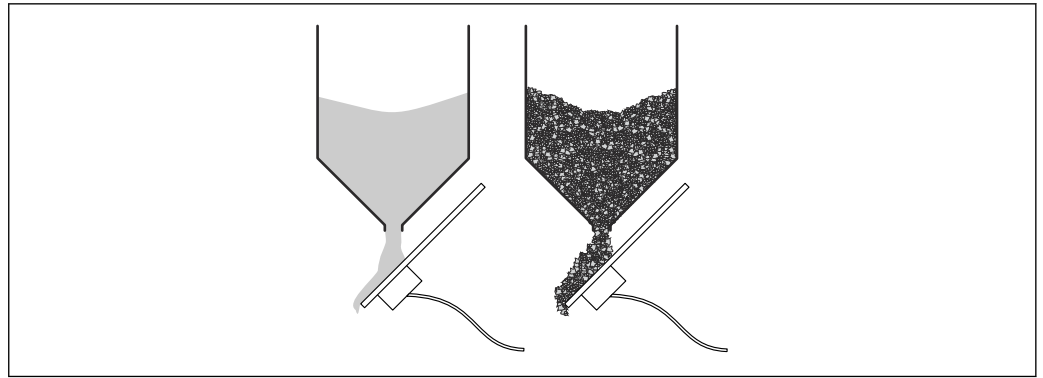

5 Installation of the round sensor for the measurement of bulk solids under silo discharge hatches

Thanks to the device's rugged design, it can be installed directly under the opening hatch of a silo without any difficulties.

Advantages of mounting under the opening hatch of a silo:

- The flow of material, and therefore the material density, is constant during the measurement
- As a result of the pressure from the material, the sensor surface undergoes constant cleaning, which helps to prevent the formation of buildup and incorrect measurements. Material caking can be checked visually, which would not be possible inside the silo.
- The sensor can clearly detect the start and end of a batch. As a result, in the CH or CC operating mode (no switch signal) the sensor can automatically totalize moisture quantity measurements in one batch process. This makes precise and representative moisture measurements possible even with smaller volumes. PLC programming can be implemented more easily without a switch signal.

Installation of the round sensor under the silo discharge hatch

- Select the correct bracket angle to suit the material. The angle must be neither too steep nor too flat to ensure that no water can accumulate on the surface of the sensor.
- The flow of material should be directed at or "against" the sensor surface.
- When the material is flowing, the surface of the sensor should be covered completely by a layer of material at least 60 mm (2.36 in) high (moisture-dependent).
- The opening hatch of the silo should be located just below the upper edge of the baffle plate to ensure that the sensor is completely covered by material.

Example: Cereal or animal feed

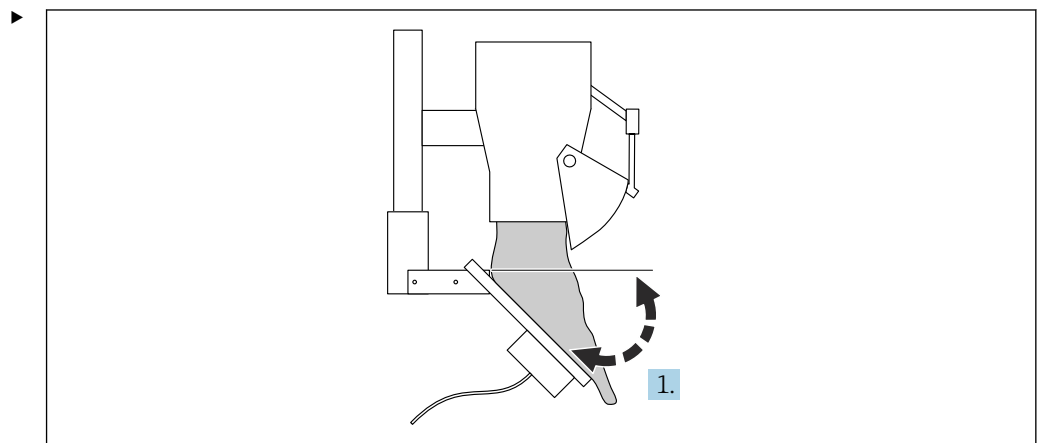

6 Cereal or animal feed, positioning of baffle plate - opening hatch

1. Set the installation angle to 45 to 55°.

Example: abrasive bulk solids

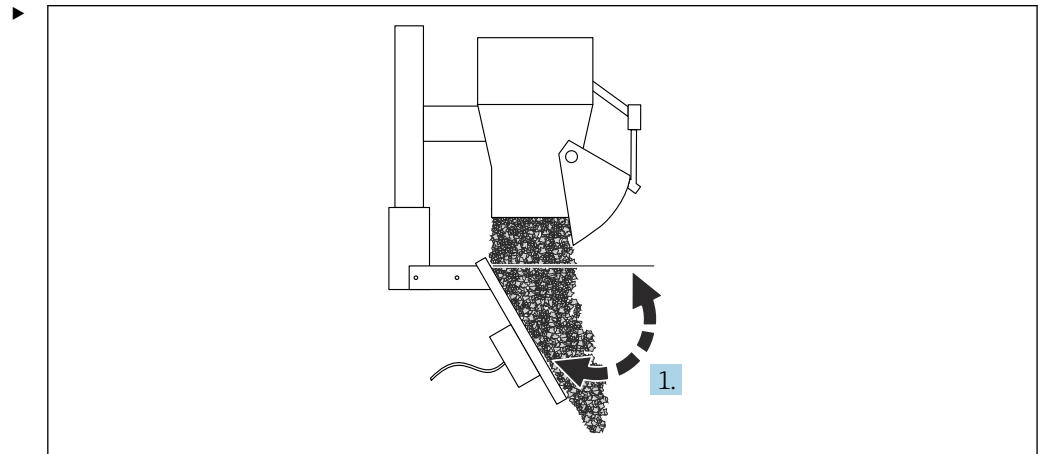

A0037439

7 Abrasive bulk solids, positioning of baffle plate - opening hatch

1 Set the installation angle to 55 to 70 °.

i Ideally, the device is attached under the hatch in such a way that the first material to fall out of the silo discharge hatch will first flow over the baffle plate and then over the sensor, and not that it only flows over the sensor when the hatch is fully opened. This improves moisture measurement in short batches in the CH mode if the silo discharge hatch is only open briefly (2 to 3 s).

Installation of the round sensor over a conveyor belt

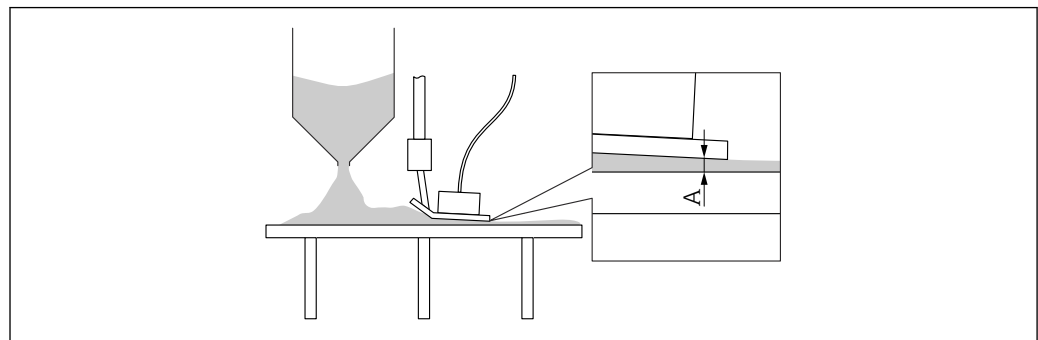

A0037437

8 Installation of the round sensor over a conveyor belt.

A Minimum sensor coverage; depends on the type of sensor used

i It is important to find the right bracket angle (2 to 3 °) depending on the material. The angle must not be too steep or too flat, depending on the material on the conveyor belt. It is also important that the entire surface of the sensor is completely covered when the material is flowing. However, material should also not collect or accumulate.

Using a sliding carriage

A sliding carriage made of 1.4301 steel is available for moisture measurements of materials on a conveyor belt.

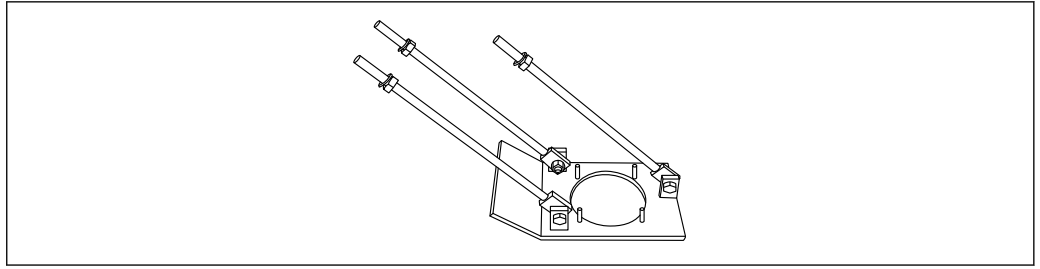

A0043696

9 Sliding carriage 1.4301, uncoated sliding surface

Suitable threaded bolts are supplied for the sliding carriage.

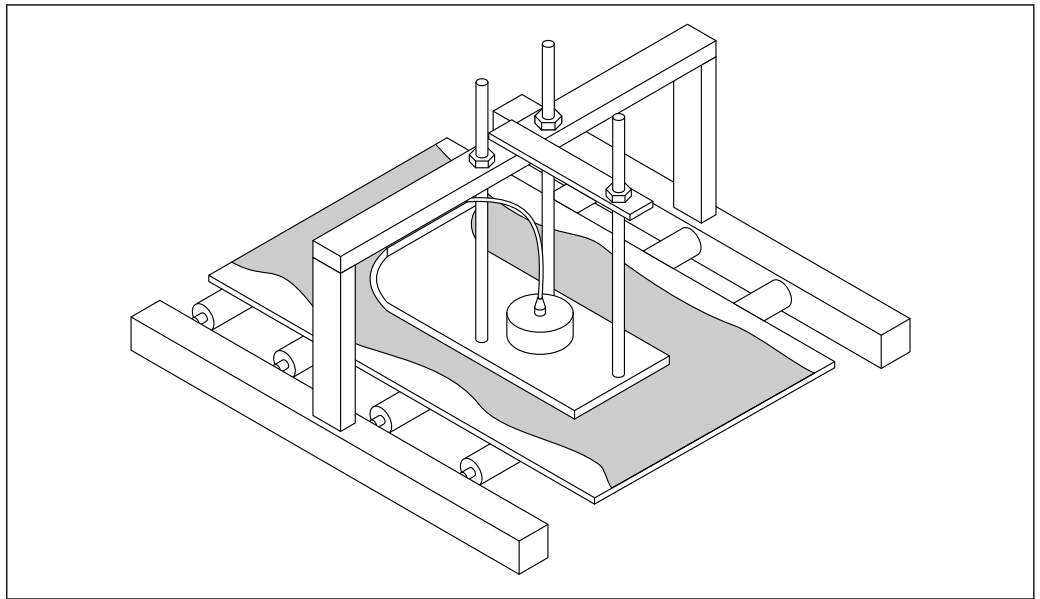

A0037441

10 Installation example of the sliding carriage

i The bracket must be made by the user, depending on the conveyor belt.

Installation of the round sensor in a vibrating chute

It is possible to install the round sensor directly in a vibrating chute. The sensor should be installed at a point where the depth of the material covering the surface of the probe is guaranteed to be > 60 mm (moisture-dependent).

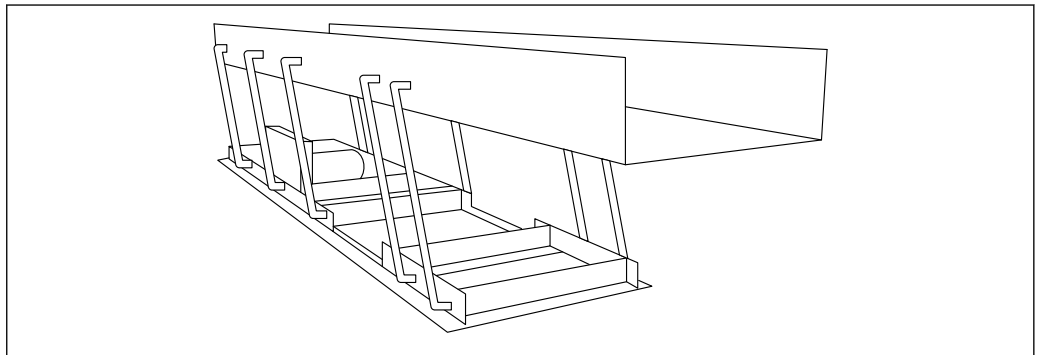

A0037444

11 Vibrating chute

Special mounting instructions**Round sensor**

- The round sensor can be attached above a conveyor belt with the optional universal bracket or sliding carriage. This can result in the constant compaction of materials, and therefore more precise measurements, particularly in the case of materials that are heterogeneous or flow very loosely. As the sensor is pressed against the material to be measured, this also helps to prevent caking.
- If floors or surfaces are uneven, the round sensor must be mounted at the highest point on the floor. Water must not be allowed to collect on the measuring cell, as this could falsify the measurement.
- If the round sensor is installed in areas with severe turbulence, it is recommended to use the CA or CK operating mode with a longer averaging time.
- Any stirring action of vanes and scrapers over the measuring cell should be gap-free so that a solid layer of material cannot form on the surface.
- The round sensor should not be installed in the immediate vicinity of electrical sources of interference such as motors.
- In the case of curved installation surfaces in cylindrical vessels, the center of the sensor should be flush with the radius of the vessel wall without interfering with the radial material flow in the vessel. The sensor should not protrude or be hit by vanes or scrapers.

Environment

Ambient temperature range	At the housing: -40 to +70 °C (-40 to +158 °F)
----------------------------------	--

Storage temperature	-40 to +70 °C (-40 to +158 °F)
----------------------------	--------------------------------

Operating altitude	Up to 2 000 m (6 600 ft) above sea level
---------------------------	--

Degree of protection	IP67
-----------------------------	------

Process

Process temperature range	<ul style="list-style-type: none"> ■ Standard, 0 to 70 °C (32 to 158 °F) ■ High-temperature version (electronics unit in separate housing), 0 to 120 °C (32 to 248 °F) (not available for the short round sensor)
----------------------------------	---

 Moisture measurement below 0 °C (32 °F) is not possible.
Frozen water (ice) cannot be detected.

Mechanical construction

Design

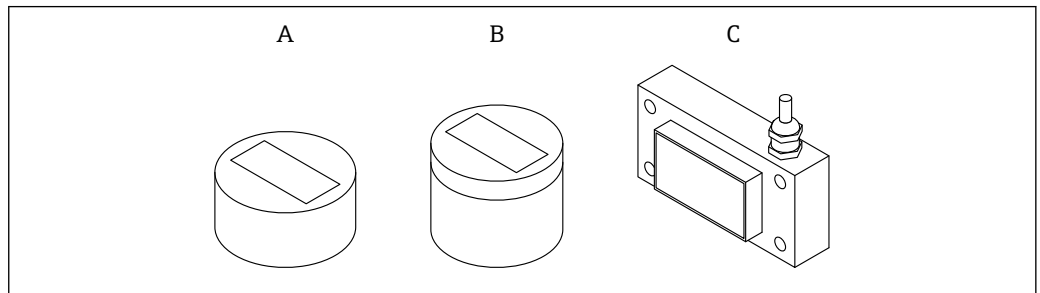

A0040207

12

- A Round sensor, short
- B Round sensor, middle
- C Rectangular sensor

ATEX version

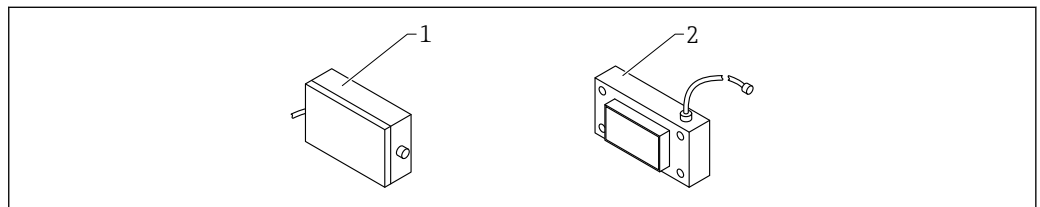

A0053310

13 Rectangular sensor, ATEX version

- 1 ATEX electronics housing
- 2 Rectangular sensor

Sensor temperature range up to 120 °C (248 °F)

In the case of the order option "Sensor temperature range up to 120 °C (248 °F)", the electronics module is always located in a separate housing and is connected using the HF cable that is permanently connected to the sensor (round sensor, middle version or rectangular sensor).

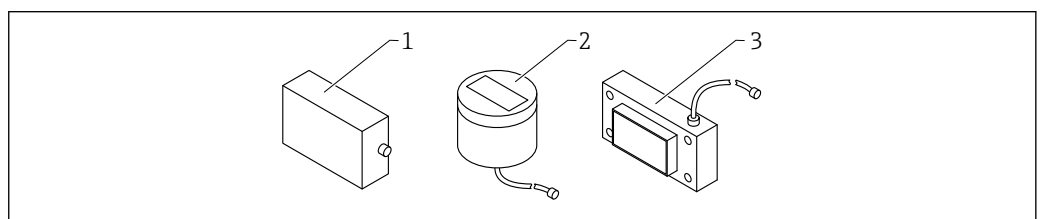

A0044424

- 1 Electronics housing
- 2 Round sensor, middle with HF cable 2.5 m (8.2 ft)
- 3 Rectangular sensor with HF cable 2.5 m (8.2 ft)

Dimensions

Round sensor, short

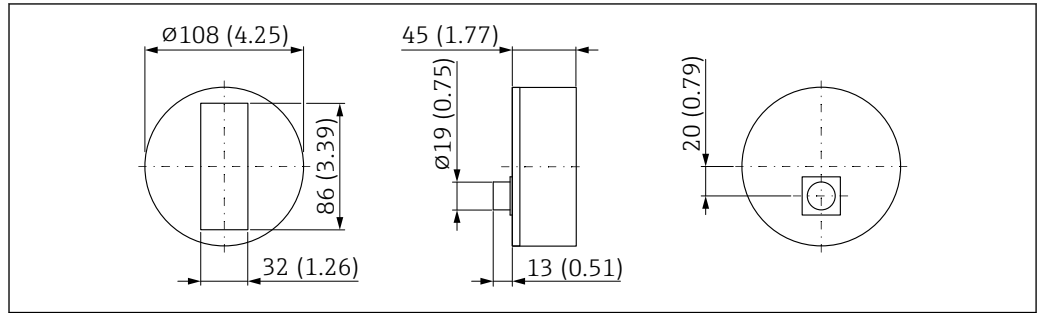

A0044504

14 Dimensions of round sensor, short. Unit of measurement mm (in)

Round sensor, middle

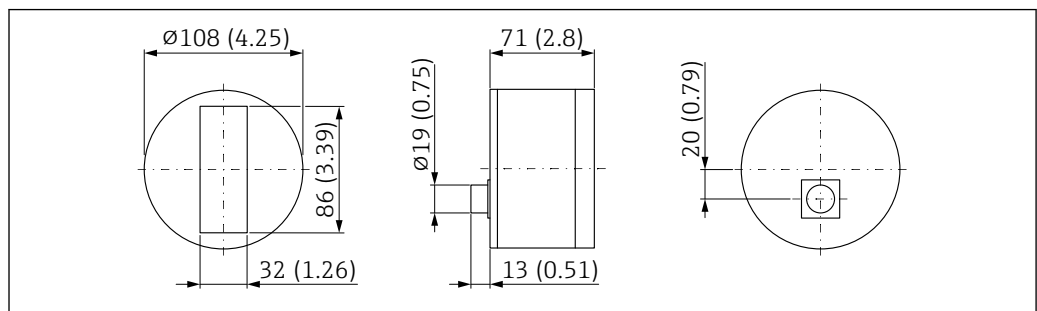

A0044503

15 Dimensions of round sensor, middle. Unit of measurement mm (in)

Mounting flange $\varnothing 108$ mm, 1.4301

The mounting flange for the round sensor, short version or for the round sensor, middle version can be mounted on the floor or on the side wall of the vessel.

The mounting flange for the round sensor, short version or for the round sensor, middle version is normally ordered together with the device via the product order structure.

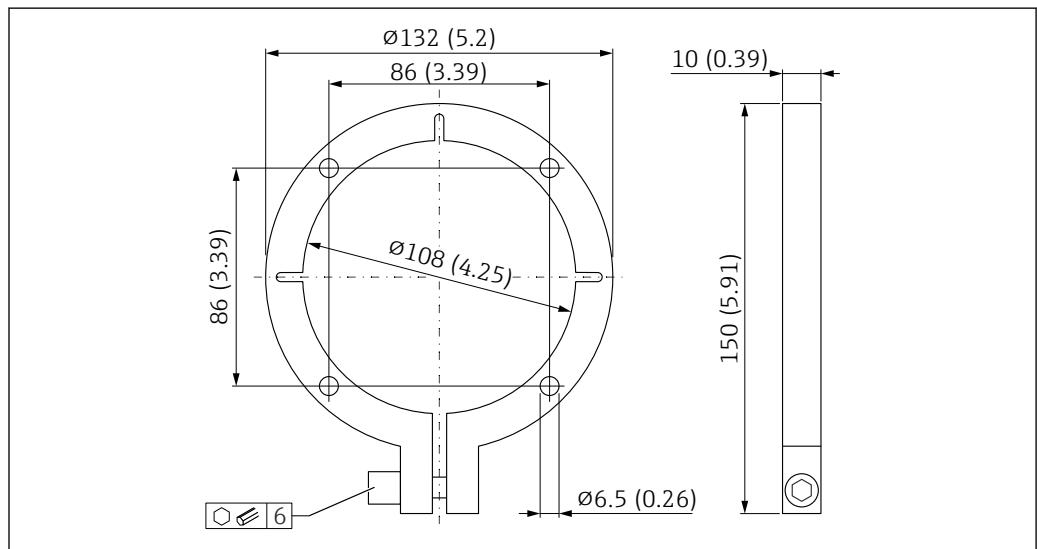

A0037423

16 Mounting flange, 1.4301, for round sensor, short version or round sensor, middle version

Rectangular sensor

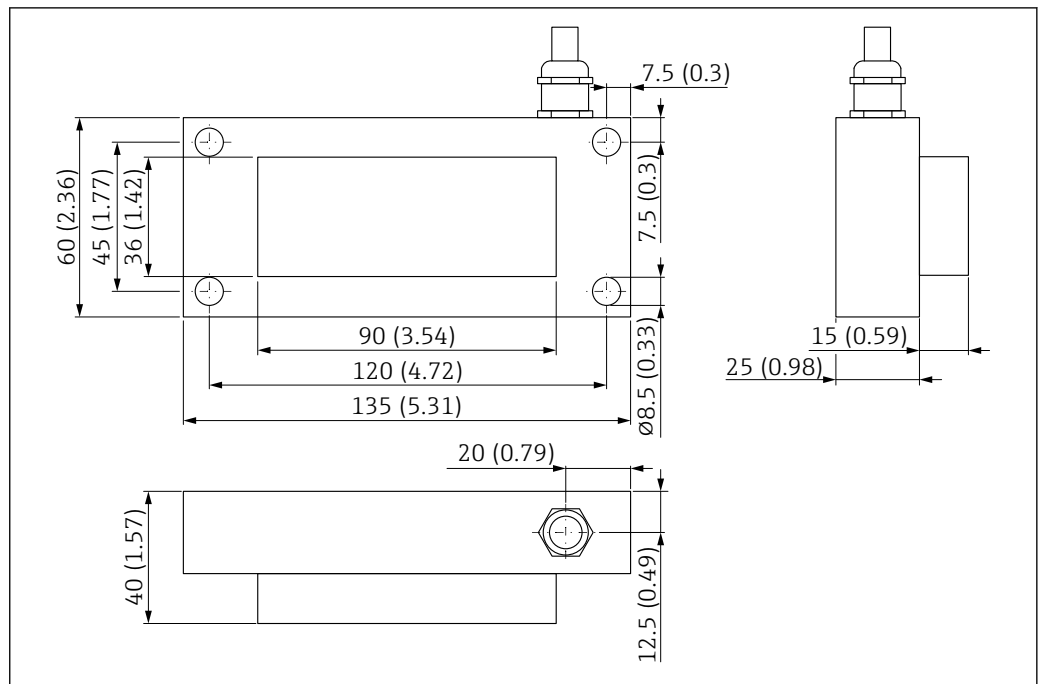

A0037426

17 Dimensions of rectangular sensor. Unit of measurement mm (in)

ATEX electronics housing

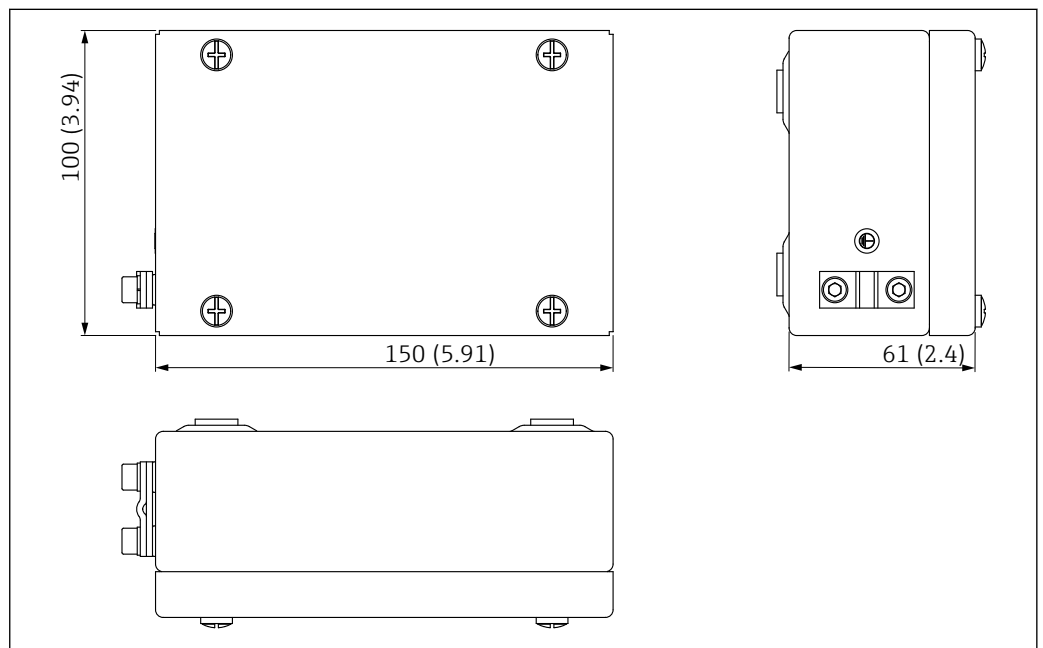

A0053050

18 Dimension of ATEX electronics housing. Unit of measurement mm (in)

Housing for remote electronics module

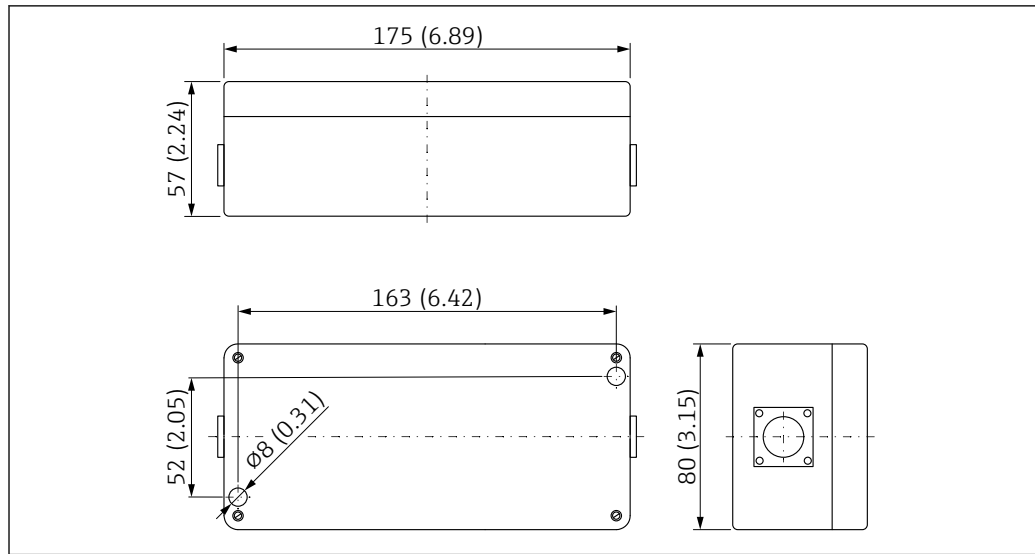

19 Dimensions of housing for remote electronics module. Unit of measurement mm (in)

Weight

Round sensor, short

Weight without packaging and accessories:
1.25 kg (2.76 lb)

Round sensor, middle

Weight without packaging and accessories:
2.55 kg (5.62 lb)

Rectangular sensor

Weight without packaging and accessories:
1.27 kg (2.8 lb)

ATEX electronics housing

Weight without packaging and accessories:
1.8 kg (3.97 lb)

Materials

Round sensor, short

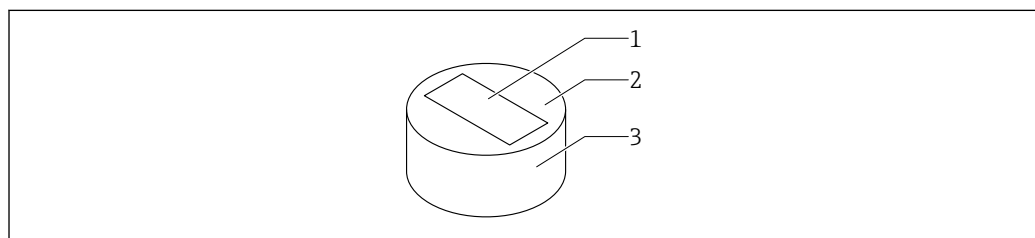

20 Materials of round sensor, short

- 1 Measuring cell; ceramic (aluminum oxide)
- 2 Sensor plate; 1.4301
- 3 Housing; 1.4301

Round sensor, middle

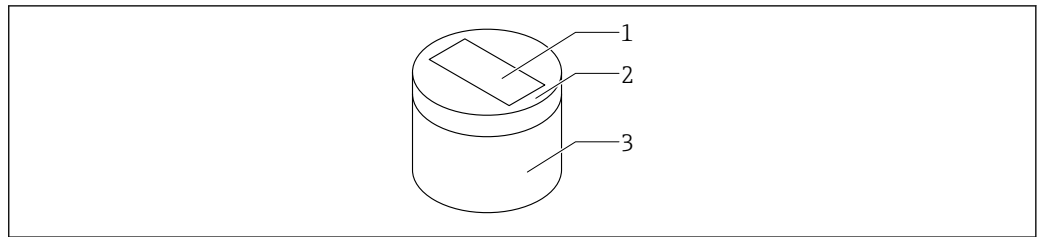

A0040106

21 Materials of round sensor, middle

- 1 Measuring cell; ceramic (aluminum oxide)
- 2 Sensor head (replaceable); 1.4301
- 3 Housing; 1.4301

Rectangular sensor

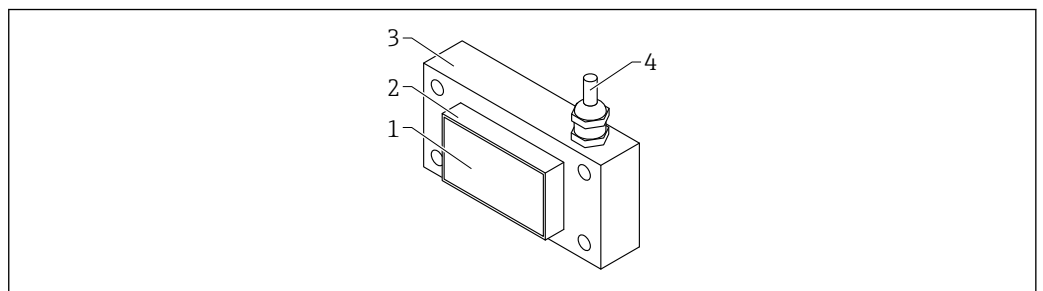

A0040108

22 Materials of rectangular sensor

- 1 Measuring cell; ceramic (aluminum oxide)
- 2 Sensor head; 1.4301
- 3 Housing; 1.4301
- 4 Cable; UNITRONIC PUR CP

ATEX electronics housing

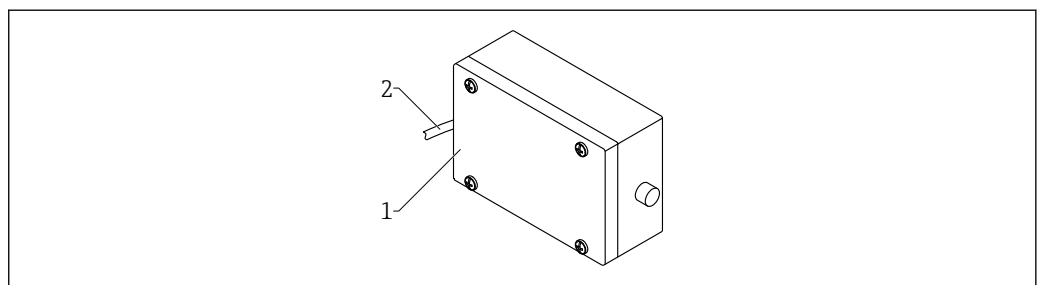

A0053051

23 Material of ATEX electronics housing

- 1 Housing; 1.4404
- 2 Cable; UNITRONIC PUR CP

Certificates and approvals

Current certificates and approvals for the product are available at www.endress.com on the relevant product page:

1. Select the product using the filters and search field.
2. Open the product page.
3. Select **Downloads**.

Ordering information

Detailed ordering information is available from your nearest sales organization www.addresses.endress.com or in the Product Configurator at www.endress.com:

1. Select the product using the filters and search field.
2. Open the product page.
3. Select **Configuration**.



Product Configurator - the tool for individual product configuration

- Up-to-the-minute configuration data
- Depending on the device: direct input of information specific to the measuring point, such as the measuring range or operating language
- Automatic verification of exclusion criteria
- Automatic creation of the order code and its breakdown in PDF or Excel output format
- Ability to order directly in the Endress+Hauser Online Shop

Accessories

Device-specific accessories

Baffle plate for round sensor

The baffle plate, 1.4301 for the round sensor, can be ordered together with the device via the "Accessory enclosed" section of the product order structure.

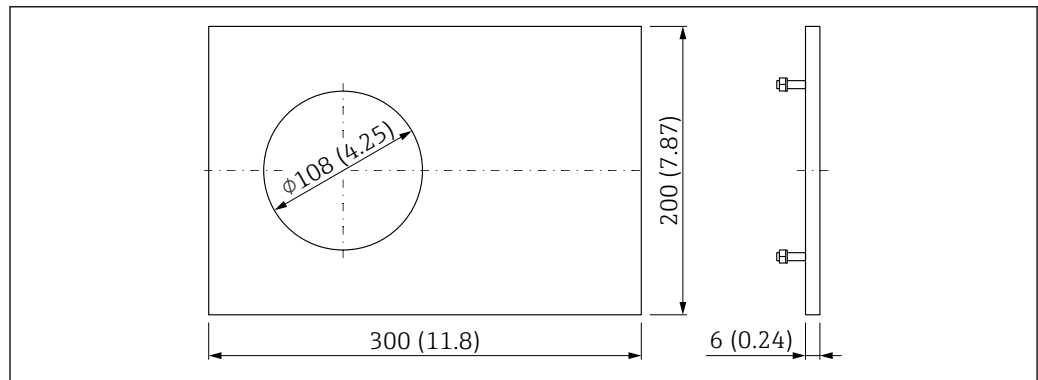

24 Baffle plate, 1.4301, sensor cut-out $\varnothing 108$ mm (4.25 in). Unit of measurement mm (in)

Universal holder with tilt mechanism for round sensor

The universal holder, 1.4301 for the round sensor, can be ordered together with the device via the "Accessory enclosed" section of the product order structure.



Tilt mechanism with retaining head. For installing the device beneath a silo hatch or above a conveyor belt.

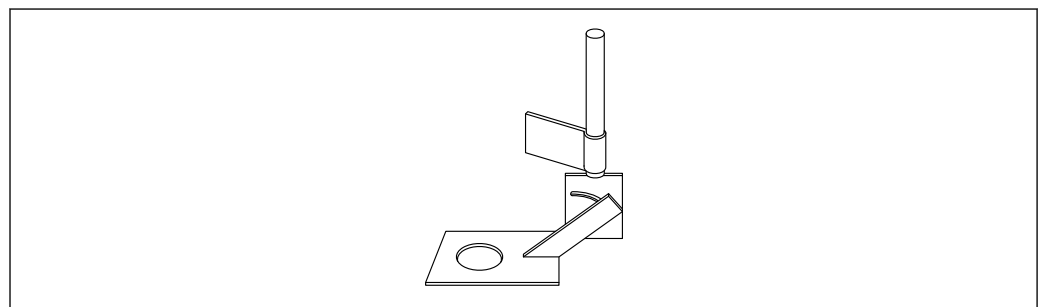

25 Universal holder, 1.4301, with tilt mechanism and retaining head, sensor cut-out $\varnothing 108$ mm (4.25 in)

Sliding carriage for round sensor

The sliding carriage for the round sensor can be ordered together with the device via the "Accessory enclosed" section of the product order structure.

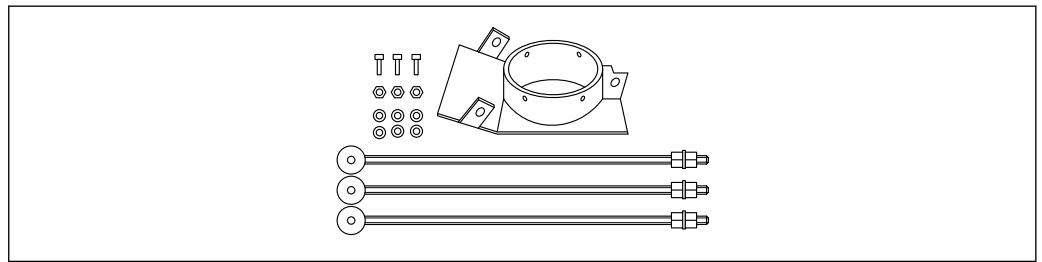

A0037578

26 Sliding carriage, sensor recess $\varnothing 108$ mm (4.25 in)

Materials

- Fastening:
1.4301
- Sliding carriage:
1.4301
- Sliding surface:
1.4301, uncoated
- 3 × threaded bolts for fastening



For installation on conveyor belts.

Documentation

The following document types are available in the Downloads area of the Endress+Hauser website (www.endress.com/downloads):



For an overview of the scope of the associated Technical Documentation, refer to the following:

- *Device Viewer* (www.endress.com/deviceviewer): Enter the serial number from the nameplate
- *Endress+Hauser Operations app*: Enter serial number from nameplate or scan matrix code on nameplate.

Brief Operating Instructions (KA)

Guide that takes you quickly to the 1st measured value

The Brief Operating Instructions contain all the essential information from incoming acceptance to initial commissioning.

Operating Instructions (BA)

Your reference guide

These Operating Instructions contain all the information that is required in various phases of the life cycle of the device: from product identification, incoming acceptance and storage, to mounting, connection, operation and commissioning through to troubleshooting, maintenance and disposal.

Safety Instructions (XA)

Depending on the approval, the following Safety Instructions (XA) are supplied with the device. They are an integral part of the Operating Instructions.



The nameplate indicates the Safety Instructions (XA) that are relevant to the device.



www.addresses.endress.com
