

Safety Instructions

Liquiline CM442, CM444, CM448, CM442R, CM444R, CM448R, CM44P

Universal four-wire multichannel controller

CSA CL I, DIV 2, GP A-D T4A





Liquiline CM442, CM444, CM448, CM442R, CM444R, CM448R, CM44P

Universal four-wire multichannel controller

Table of contents

CD version	4
CL version	7
Control drawing	14

CD version**Associated documentation**

This document is an integral part of Operating Instructions BA00444C, BA01225C, BA01570C and BA01954C.

Documentation

Competence Brochure CP00021Z

- Explosion Protection: Guidelines and General Principles
- www.endress.com

Certificate

CSA C/US certificate

Certificate number:

CSA 10CA80094716

The certificates and declarations of conformity are available in the download area of the Endress+Hauser website:

www.endress.com/download

Standards

The following standards have been applied:

- CAN/CSA C22.2 No. 61010-1-12
- ANSI/UL 61010-1-2012 Third Edition
- CSA C22.2 No. 94.2-15
- ANSI/UL 50E-2015 Second Edition
- CAN/CSA C22.2 No. 213-15
- UL 121201-2019 Ninth Edition

Identification*Nameplate*

The following information on the device can be found on the nameplate:

- Manufacturer identification
- Order code
- Extended order code
- Serial number
- Firmware version
- Ambient conditions
- Input and output values
- Activation codes
- Safety information and warnings
- Degree of protection
- Ex markings
- CSA C/US mark
- Warnings
- Control drawing number
- Certificate number

- ▶ Compare the information on the nameplate with the order.

Type code

CSA

Type	Version	*	*	**	*	***	+*
CM442 CM444 CM448 CM442R CM444R CM448R CM44P	CD						
	CL I. DIV 2 GP A-D T4A	No Ex relevance					

*Certificates and approvals**Ex approval*

CL I, DIV 2, GP A-D T4A

The product meets the requirements of:

- **CLASS 2258 03** PROCESS CONTROL EQUIPMENT - Intrinsically Safe and Non-incendive Systems - For Hazardous Locations
- **CLASS 2258 83** PROCESS CONTROL EQUIPMENT - Intrinsically Safe and Non-incendive Systems - For Hazardous Locations - Certified to US Standards

Safety instructions

- The Liquiline CM442, CM444, CM448, CM442R, CM444R, CM448R and CM44P can be set up in the CL I, DIV 2 area.
- Only an CL I, DIV 2 approved electrical apparatus may be connected to the input.
- Liquiline CM442-CD, CM444-CD, CM448-CD, CM442R-CD, CM444R-CD, CM448R-CD, CM44P-CD providing non-incendive field wiring connection to field sensors when installed per control drawing 961006059.
- Only suitable sensors may be connected and used as designated in the control drawing.
- Power to railmount transmitters CM442R, CM444R, CM448R, and CM44P (DIN) to be supplied only by power supplies certified for Class I, Division 2, Groups A-D.
- The CM442R, CM444R, CM448R, and CM44P (DIN) are OPEN type equipment that must be used within a suitable end-use system enclosure, the interior of which, is accessible only through the use of a tool.
- The suitability of the enclosure is subject to investigation by the local Authority having Jurisdiction at the time of installation (AHJ).
- Wiring to or from this device, which enters or leaves the system enclosure, must utilize wiring methods suitable for Class I, Division 2 Hazardous Locations, as appropriate for the installation.
- External graph display, cabinet 71185295 for CM442R, CM444R, CM448R, CM44P-CDDIN; ambient temperature -20 °C to 60 °C (-4 °F to 140 °F); IP66/ Type 4X enclosure. To be installed as per control drawing 961006059.
- Ex-certified devices may only be maintained by the manufacturer's service personnel.
- Ensure strict compliance with the applicable standards, national regulations for hazardous areas and the safety instructions in the operating manuals and certificates.
- Only use original spare parts from the manufacturer.
- When ordering spare parts, pay attention to the device designation on the nameplate. Parts can only be replaced with identical parts or parts approved for this purpose.
- Each repair or modification to the device must be documented.
- The safety of any system incorporating the equipment, is in the responsibility of the assembler of the system.
- All circuits - apart from the mains supply circuits (power supply of device and relay connection) - that are directly connected to Liquiline CM442, CM444, CM448, CM442R, CM444R, CM448R or CM44P must be safety extra low voltage signals. They must correspond to SELV or PELV circuits or the directly connected devices must correspond to ANSI/UL 61010, CAN/CSA C22.2 No. 61010, IEC 60950 series, IEC 61010-1 or a technically equivalent standard.
- The transmitter may only be used for fixed installations. The cables must be strain-relieved and securely connected.
- Secure the cable glands so that they do not become loose and fit the seals directly on the housing. Ensure that the cable glands and cable entries are leak-tight. To ensure leak-tight fastening, the cable gland and the cable nuts must be tightened with a torque of 2 Nm after the cables have been routed through the gland.
- Pay attention to the information in the Operating Instructions regarding the nominal values of the input and output circuits.
- The device configuration and hardware may not be modified as this would invalidate the explosionprotection. Every change puts safety at risk and results in loss of Ex-approval. This applies for all modules of the transmitter.
- Installation, connection to the power supply, commissioning and inspection be performed by qualified skilled staff who are appropriately trained to perform work on Ex devices in accordance with the applicable regulations, e.g. according to National Electrical Code (NFPA70) or the Canadian Electrical Code, Part 1 (C22.1) and the local requirements. The instructions in the Operating Instructions must be strictly observed.
- The ambient temperature range must be observed in accordance with the temperature table below.
- The antenna and antenna cable of the EMR module are not certified for CL I DIV 2 and therefore must not be used in explosive environments.

Temperature tables

Device / module	Ambient temperature T_a
CM442-CD	$-20\text{ °C} \leq T_a \leq +60\text{ °C}$ ($-4\text{ °F} \leq T_a \leq +140\text{ °F}$)
CM444-CD CM448-CD CM44P-CDFIH	$-20\text{ °C} \leq T_a \leq +50\text{ °C}$ ($-4\text{ °F} \leq T_a \leq +122\text{ °F}$)
CM442R-CD	$0\text{ °C} \leq T_a \leq +60\text{ °C}$ ($32\text{ °F} \leq T_a \leq +140\text{ °F}$)
CM444R-CD CM448R-CD CM44P-CDDIN	$0\text{ °C} \leq T_a \leq +50\text{ °C}$ ($32\text{ °F} \leq T_a \leq +122\text{ °F}$)

Connection*Mounting requirements*

See attached control drawing.

CL version**Associated documentation**

This document is an integral part of Operating Instructions BA00444C, BA01225C, BA01570C and BA01954C.

Documentation

Competence Brochure CP0002 1Z

- Explosion Protection: Guidelines and General Principles
- www.endress.com

Certificate

CSA C/US certificate

Certificate number:

CSA 10CA80094716

The certificates and declarations of conformity are available in the download area of the Endress+Hauser website:

www.endress.com/download

Standards

The following standards have been applied:

- CAN/CSA C22.2 No. 61010-1-12
- ANSI/UL 61010-1-2012 Third Edition
- CSA C22.2 No. 94.2-15
- ANSI/UL 50E-2015 Second Edition
- CAN/CSA C22.2 No. 60079-0:19
- ANSI/UL 60079-0-2019 Seventh Edition
- CAN/CSA C22.2 No. 60079-11:14 (R2018)
- ANSI/UL 60079-11-2013 Sixth Edition
- CAN/CSA C22.2 No. 213-17 Third Edition (R2022)
- UL 121201-2019 Ninth Edition

Identification*Nameplate*

The following information on the device can be found on the nameplate:

- Manufacturer identification
 - Order code
 - Extended order code
 - Serial number
 - Firmware version
 - Ambient conditions
 - Input and output values
 - Activation codes
 - Safety information and warnings
 - Degree of protection
 - Ex markings
 - CSA C/US mark
 - Warnings
 - Control drawing number
 - Certificate number
- Compare the information on the nameplate with the order.

Type code

CSA

Type	Version						
CM442 CM444 CM448 CM442R CM444R CM448R CM44P	CL	*	*	**	*	***	+*
	CL I, DIV 2, GP A-D, T4A; Associated Intrinsically Safe outputs to Class I Division 1, Group A-D [Ex ia Ga] IIC	No Ex relevance					

*Certificates and approvals**Ex approval*

CL I, DIV 2, GP A-D T4A;

Associated Intrinsically Safe outputs to CL I, DIV 1, GP A-D [Ex ia Ga] IIC

The product meets the requirements of:

- **CLASS 2258 03** PROCESS CONTROL EQUIPMENT - Intrinsically Safe and Non-incendive Systems - For Hazardous Locations
- **CLASS 2258 83** PROCESS CONTROL EQUIPMENT - Intrinsically Safe and Non-incendive Systems - For Hazardous Locations - Certified to US Standards

Safety instructions

- The sensor communication module 2DS Ex-i in the Liquiline CM442, CM444, CM448, CM442R, CM444R, CM448R and CM44P transmitter is an associated apparatus.
- The Liquiline CM442, CM444, CM448, CM442R, CM444R, CM448R and CM44P can be set up in the CL I, DIV 2 area.
- Only an intrinsically safe electrical apparatus may be connected to the intrinsically safe digital sensor input.
- Liquiline CM442-CL, CM444-CL, CM448-CL, CM442R-CL, CM444R-CL, CM448R-CL, CM44P-CL Providing associated Intrinsically Safe connections to field sensors from installed 2DS Ex I modules (terminals 87i, 88i, 97i, 98i) when installed per control drawing 961006059.
- Only suitable sensors may be connected and used as designated in the control drawing.
- Power to railmount transmitters CM442R, CM444R, CM448R, and CM44P (DIN) to be supplied only by power supplies certified for Class I, Division 2, Groups A-D.
- All railmount devices are OPEN type equipment that must be used within a suitable end-use system enclosure, the interior of which is accessible only through the use of a tool. The suitability of the enclosure is subject to investigation by the local Authority having Jurisdiction at the time of installation (AHJ).
- All circuits - apart from the mains supply circuits (power supply of device and relay connection) that are directly connected to Liquiline CM442, CM444, CM448, CM442R, CM444R, CM448R and CM44P with an integrated sensor communication module 2DS Ex-i must be safety extra low voltage signals. They must correspond to SELV or PELV circuits or the directly connected devices must correspond to ANSI/UL 61010, CAN/CSA C22.2 No. 61010, IEC 60950 series, IEC 61010-1 or a technically equivalent standard.
- Wiring to or from this device, which enters or leaves the system enclosure, must utilize wiring methods suitable for Class I, Division 2 Hazardous Locations, as appropriate for the installation.
- External graph display, cabinet 71185295 for CM442R, CM444R, CM448R, CM44P CLDIN; ambient temperature -20 °C to 60 °C (-4 °F to 140 °F); IP66/ Type 4X enclosure. To be installed as per control drawing 961006059.
- The transmitter may only be used for fixed installations. The cables must be strain-relieved and securely connected.
- Secure the cable glands, so that they do not become loose and fit the seals directly on the housing. Ensure that the cable glands and cable entries are leak-tight. To ensure leak-tight fastening, the cable gland and the cable nuts must be tightened with a torque of 2 Nm after the cables have been routed through the gland.

- Pay attention to the information in the Operating Instructions regarding the nominal values of the input and output circuits.
- The device configuration and hardware may not be modified as this would invalidate the explosion protection. Every change puts safety at risk and results in loss of Ex-approval. This applies for all modules of the transmitter, including the non-intrinsically safe modules.
- Ex-certified devices may only be maintained by the manufacturer's service personnel.
- Ensure strict compliance with the applicable standards, national regulations for hazardous areas and the safety instructions in the operating manuals and certificates.
- Each repair or modification to the device must be documented.
- When wiring the modules, it is important to ensure that the intrinsically safe and nonintrinsically safe terminals are at least 50 mm apart (tight string length). For this purpose, the separator element that guarantees the necessary spacing is integrated between the intrinsically safe and non-intrinsically safe modules and must not be removed.
- Installation, connection to the power supply, commissioning, inspection, maintenance of the devices must be performed by qualified skilled staff who are appropriately trained to perform work on Ex devices in accordance with the applicable regulations, e.g. according to National Electrical Code (NFPA70) or the Canadian Electrical Code, Part 1 (C22.1) and the local requirements. The instructions in the Operating Instructions must be strictly observed.
- The ambient temperature range for the sensor communication module must be observed in accordance with the temperature table below.
- The antenna and antenna cable of the EMR module are not certified for CL I DIV 2 and therefore must not be used in explosive environments.

Temperature tables

Device / module	Ambient temperature T_a
2DS Ex-i module	$-20\text{ °C} \leq T_a \leq +85\text{ °C}$ ($-4\text{ °C} \leq F_a \leq +185\text{ °F}$) ¹⁾
CM442-CL CM444-CL CM448-CL CM44P-CLFIH	$-20\text{ °C} \leq T_a \leq +50\text{ °C}$ ($-4\text{ °F} \leq T_a \leq +122\text{ °F}$) ²⁾
CM442R-CL CM444R-CL CM448R-CL CM44P-CLDIN	$0\text{ °C} \leq T_a \leq +50\text{ °C}$ ($32\text{ °F} \leq T_a \leq +122\text{ °F}$) ²⁾

- 1) Without installation in additional enclosure.
- 2) The temperature range of the Liquiline with integrated 2DS Ex-i modules is lower due to the self-heating of the device.

Connection

Mounting requirements

See attached control drawing.

Connection data

Connection data for the sensor communication module 2DS Ex-i, which is an associated intrinsically safe electrical apparatus and integrated in Liquiline CM442, CM444, CM448, CM442R, CM444R, CM448R and CM44P.

Intrinsically safe digital input: [Ex ia Ga] (sensor communication module 2DS Ex-i module terminal 87i, 88i, 97i, 98i)	
Max. output voltage U_o	5 V
Max. output current I_o	112 mA
Max. power P_o	165 mW
Max. internal capacitance C_i	5.2 μ F
Max. internal inductance L_i	0 μ H

Intrinsically safe digital input: [Ex ia Ga] (sensor communication module 2DS Ex-i module terminal 87i, 88i, 97i, 98i)	
Max. external capacitance C_o	Corresponding to xYK10, xYK20 ¹⁾ and CLS50D + max. 100 m cable length
Max. external inductance L_o	Corresponding to xYK10, xYK20 ¹⁾ and CLS50D + max. 100 m cable length

1) x ... C or O or OC

Max. permitted voltage at non-intrinsically safe connections on the CM442, CM444, CM448, CM442R, CM444R, CM448R and CM44P	
Max. output voltage U_m	≤ 250 VAC rms

Module integration

The sensor communication module 2DS Ex-i may only be integrated into the transmitter with the 2DS Ex-i module housing.

Liquiline CM442, CM442R

- One sensor communication module 2DS Ex-i can be integrated into a Liquiline CM442, CM442R transmitter only by the manufacturer.
- The separator element must be located between the non-intrinsically safe modules and the sensor communication module 2DS Ex-i. The separator element ensures a tight string length of at least 50 mm between the non-intrinsically safe terminals and the intrinsically safe terminals. The sensor communication module 2DS Ex-i must be integrated in slot 2

Liquiline CM444, CM444R, CM44P, CM448, CM448R

- Two sensor communication modules 2DS Ex-i can be integrated into a Liquiline CM444, CM444R, CM44P transmitter. Up to three sensor communication modules 2DS Ex-i can be integrated into a Liquiline CM448, CM448R transmitter. The separator element must be located between the non-intrinsically safe modules and the sensor communication module 2DS Ex-i. The separator elements ensure a tight string length of at least 50 mm between the non-intrinsically safe terminals and the intrinsically safe terminals.
- The separator element is integrated between slot 4 and slot 5 irrespective of the configuration of the modules.
- The sensor communication modules 2DS Ex-i may be located in slots 5, 6, 7. If a sensor communication module 2DS Ex-i is integrated into the CM44x-transmitter, a non-intrinsically safe module may not be integrated in slot 5, 6, 7.
- Empty slots to the left of the separator element (slot 2, 3, 4) must be provided with a blanking cover.
- Empty slots to the right of the separator element (slot 5, 6, 7) must be covered with a blanking cover.

Galvanic isolation

The sensor circuits of the sensor communication module 2DS Ex-i are isolated from all non-intrinsically safe circuits of the Liquiline CM442, CM444, CM448, CM442R, CM444R, CM448R, CM44P up to the specified maximum voltage U_m .

The two intrinsically safe sensor circuits of the sensor communication module 2DS Ex-i are isolated from ground potential with ≥ 500 VAC rms.

The two intrinsically safe sensor circuits of the sensor communication module 2DS Ex-i are not galvanically isolated from one another (see the graphic below).

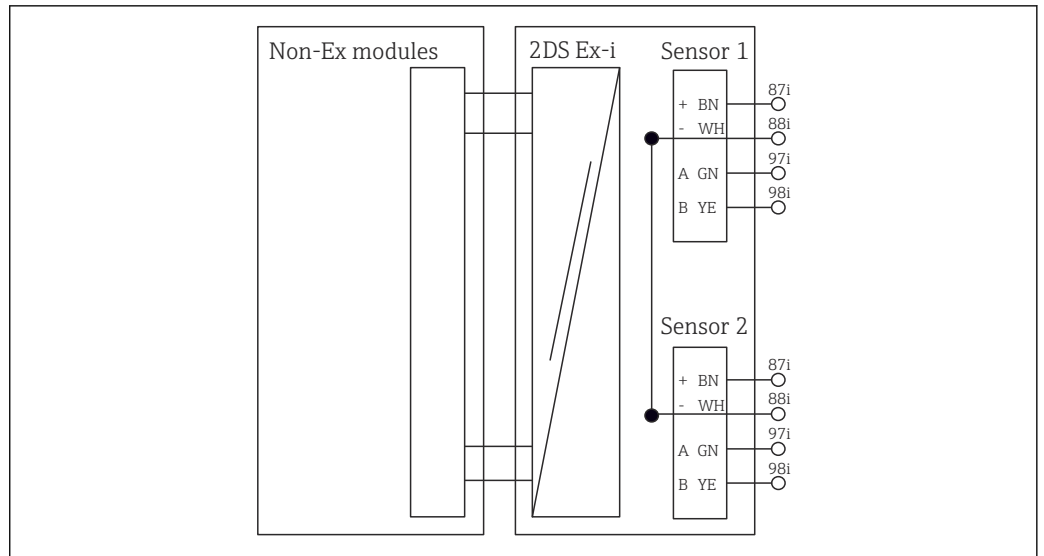

A0045630

1 $U_m = 250V, [Ex ia Ga] IIC$

If the full system installation requires two intrinsically safe circuits that are isolated from one another, the two sensor circuits must be installed on two different sensor communication modules 2DS Ex-i.

Connecting sensor circuits

Intrinsically safe digital sensors may only be connected to the sensor inputs of the sensor communication module 2DS Ex-i marked in blue.

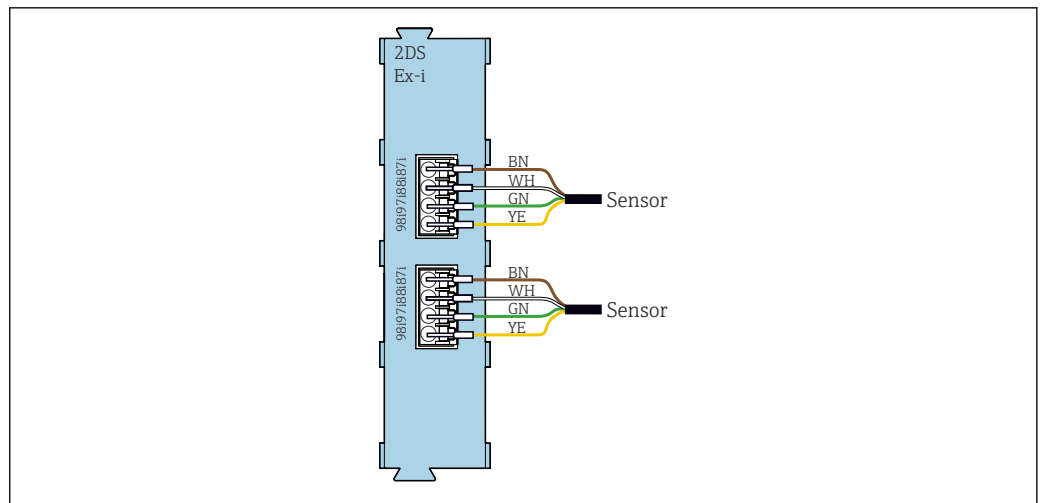

A0045631

To avoid any mix-up between intrinsically safe and non-intrinsically safe circuits, non-intrinsically safe sensors cannot be operated on a transmitter with intrinsically safe sensor circuits. The corresponding terminals are disabled.

The cable shields of the intrinsically safe sensor must be connected to ground potential at the cable mounting rail of the transmitter. There must only be one connection of the cable shield with the potential equalization system.

Intrinsically safe wiring

Intrinsically safe and non-intrinsically safe wiring of cables and connections must be established according to the separation requirements of applicable regulations, e.g. according to National Electrical Code (NFPA70) or the Canadian Electrical Code, Part 1 (C22.1) as well as the local requirements.

The cable glands must be arranged in such a way to ensure the separation of intrinsically safe and non-intrinsically safe cables and connections. In the case of devices with a field housing, it is only permitted to use the cable glands (4, 8, B, F, G, I) for the installation of the intrinsically safe sensor circuits.

A tight string length of at least 50 mm must be observed between intrinsically safe and non-intrinsically safe terminals. This is guaranteed by the separator element.

It is recommended to route the intrinsically safe and non-intrinsically safe cables in two different directions to ensure the optimum separation of the circuits.

The safety of any system incorporating the equipment is in the responsibility of the assembler of the system.

The Liquiline CM442, CM444, CM448, CM442R, CM444R, CM448R, CM44P offers two separate terminal strips for ground connections. They can be used to separate the cable shields of the intrinsically safe circuits and the cable shields of the non-intrinsically safe circuits.

CM442, CM444, CM448, CM44P-CLFIH

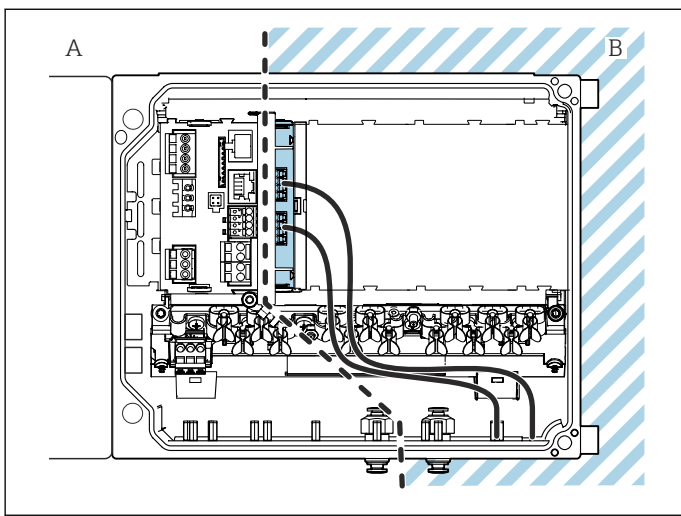

A0047418

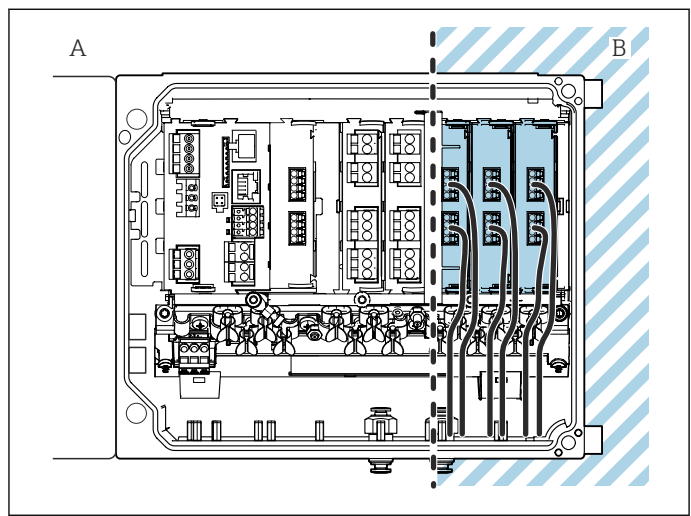

A0045721

2 Device open (CM442)

A: Non-intrinsically safe wiring

B: Intrinsically safe wiring of sensor communication module 2DS Ex-i

3 Device open (CM444, CM448, CM44P-CLFIH)

Cable entries CM442

Identification of the cable entry on housing base	Suitable gland	
B, C, H, I, 1-8	M16x1.5 mm/NPT3/8"/G3/8	
A, D, F, G	M20x1.5 mm/NPT1/2"/G1/2	
E	-	
⊕	M12x1.5 mm	
	Recommended assignment	
	1/2/3 5/6/7	Do not use
	4/8 B/F/G/I	Intrinsically safe sensors
	A	Power supply
	C	RS485 Out or M12 Ethernet
D	Current outputs and inputs, relays	

A0045661

4 A: Non-hazardous area, B: Hazardous area

Identification of the cable entry on housing base	Suitable gland	
	H	RS485 In or M12 DP/RS485
	E	Do not use

 Do not cross cables for the non-hazardous area and the hazardous area in the housing. Select a suitable cable entry for the connection.

CM442R, CM444R, CM448R, CM44P-CLDIN

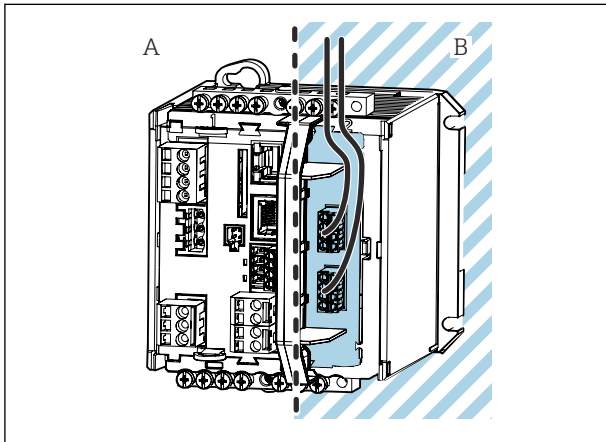

A0045633

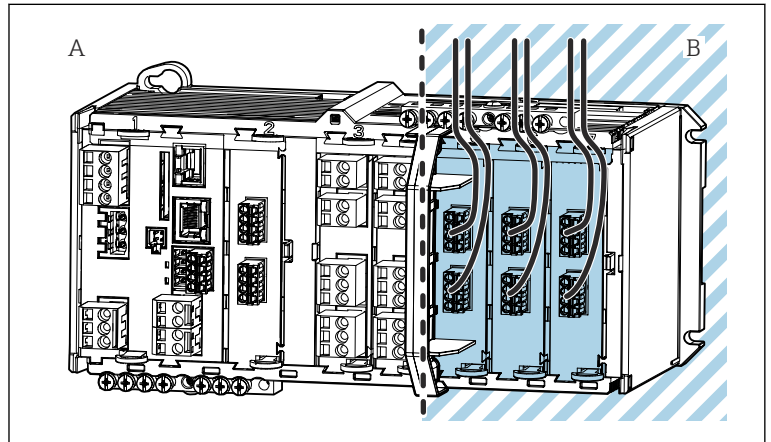

A0045632

A: Non-intrinsically safe wiring

B: Intrinsically safe wiring of sensor communication module 2DS Ex-i

Control drawing

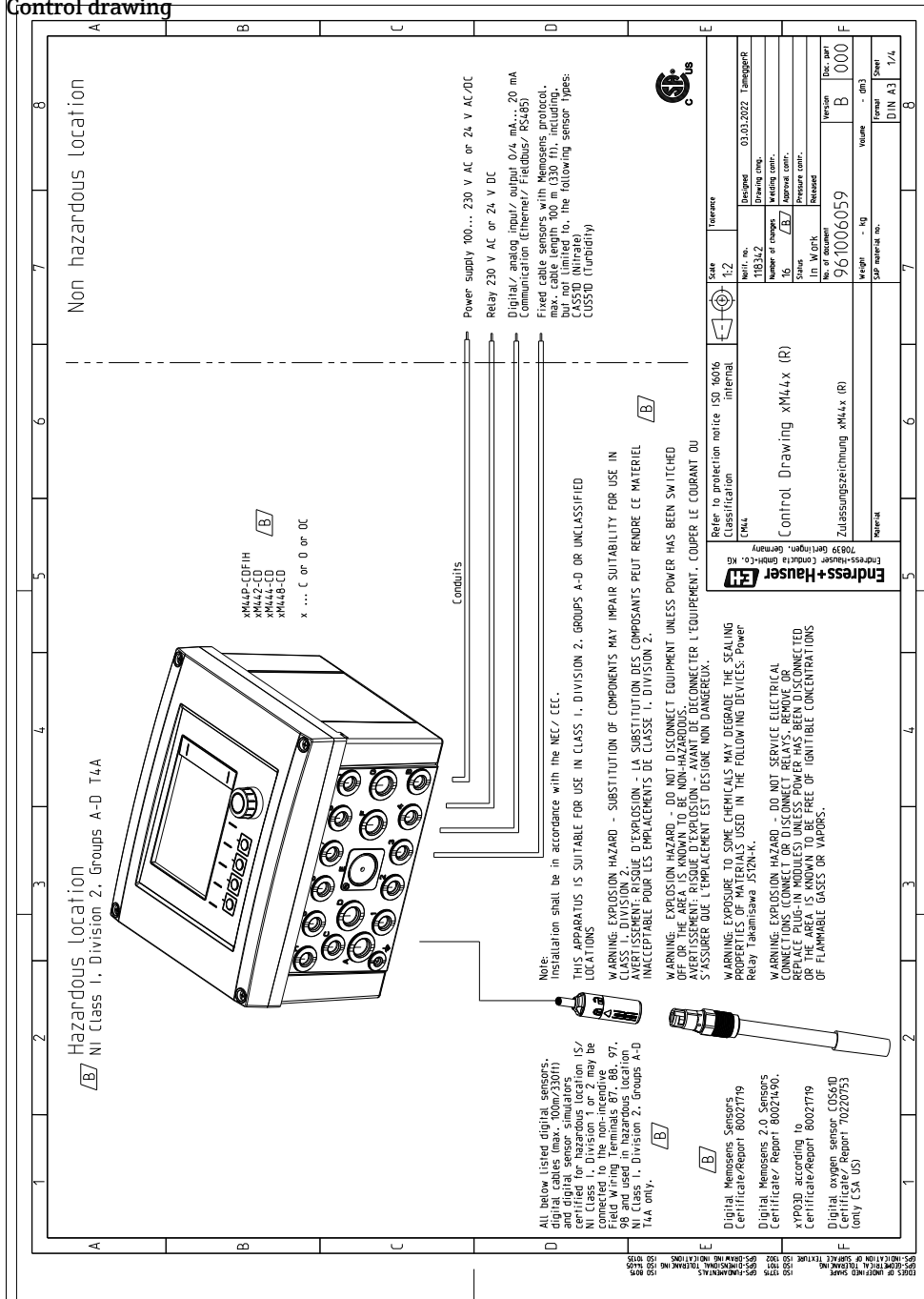

A0052616

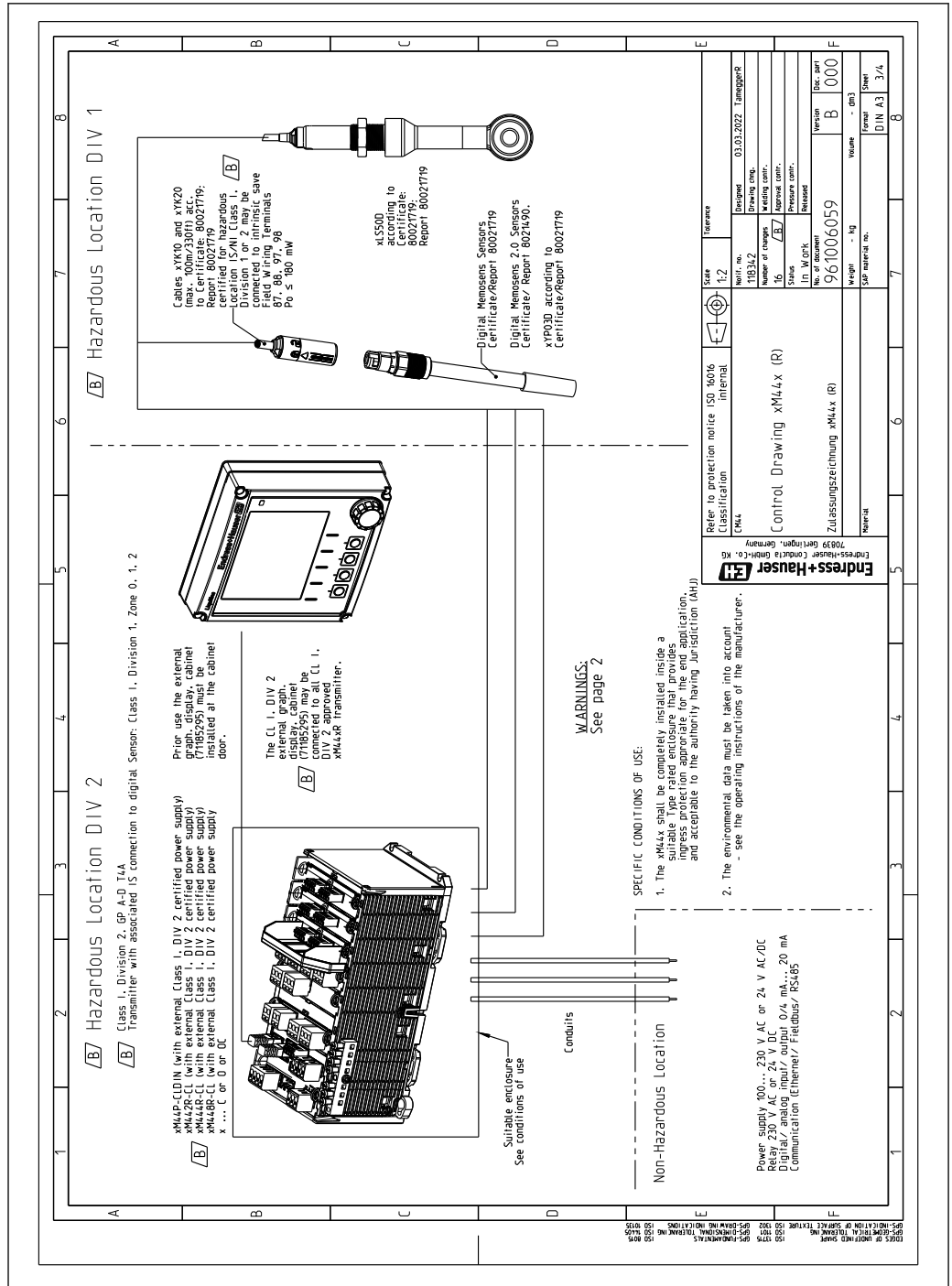

Scale	1:2	Reference	
Draw. no.	1834/2	Revision	03.02.2022 - 1. Ausgabe R.
Number of sheets	16	Working contr.	
Status	In W.D.P.K.	Approval contr.	
No. of document	961006059	Released	
Version	B	Doc. part	000
Weight	- kg	Volume	- dm ³
SAP material no.		Formal	DIN A3
		Sheet	3/4

Refer to protection notice ISO 16065	
Classification	CM44
Control Drawing	xM44x (R)
Zulassungszeichnung	xM44x (R)
Material	

Endress+Hauser
 Endress+Hauser Conducta GmbH
 70839 Gerlingen, Germany

A0052619

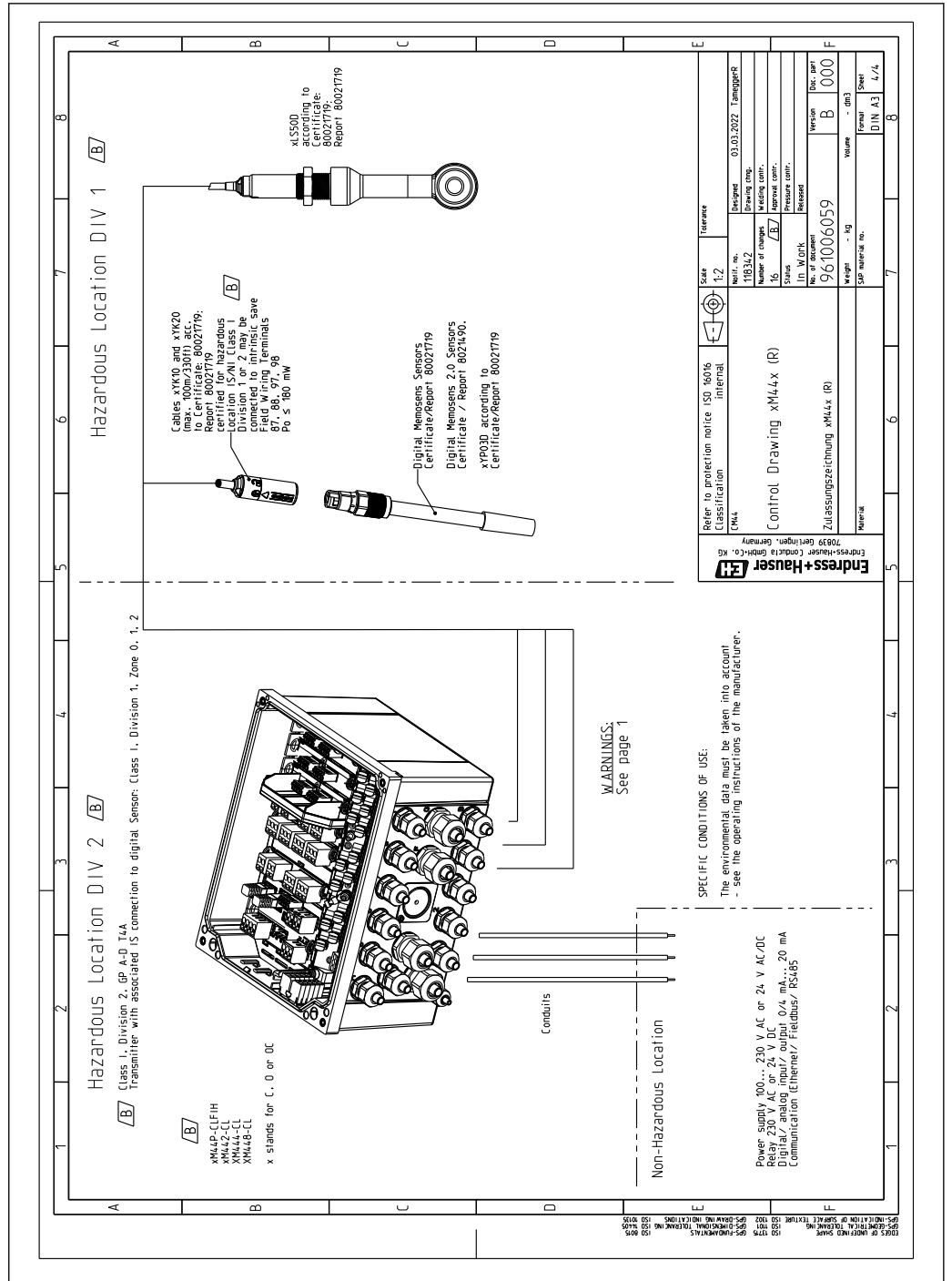

A0052620





71698212

www.addresses.endress.com
