

From the measuring point to Netilion

Dive deeper in your process data by having a constant remote overview of your measured values.



Liquiline Edge Module CYY7

The Liquiline Edge Module enables extensive data transfer from the measuring point to Netilion. Thus, it simplifies maintenance by providing a remote overview of measurement values, offering deeper insights into process data, and facilitating the use of IIoT applications. It is easy to use as it is a plug-in module that communicates independently of the present architecture and fieldbus system



Benefits at a glance

The Liquiline Edge Module CYY7 helps simplify your maintenance by providing a remote overview of all measurement values, gaining additional insights into your process data and making the best use of IIoT applications.

Cybersecurity

The Liquiline Edge Module's high security standards keep your data safe and secured. It features a unique security concept that prevents intrusion into the process.



Connection to Netilion

The Liquiline Edge Module continuously transfers data from the measuring point to the cloud-based IIoT ecosystem, Netilion. This enables you to get a remote overview of data, even from barely accessible infrastructures, and make the best use of your data and IIoT applications.



Liquiline Assist App

The comprehensible visualization, the sensor's health status and the correlation overview give you a helping hand to take full advantage of the collected data.



Saving time and money

With the unlocked data in Netilion, you can empower your field: have constant data overview from everywhere, monitor the health of devices and simplify maintenance, e.g., by receiving alerts when challenging values arise.



Order options to best suit your needs

The Liquiline Edge Module is available either as a feature when ordering a new transmitter or as an upgrade to an already installed Liquiline platform (transmitter, sampler or analyzer) as well as in radio or Ethernet variants.



Simple installation and seamless integration

The plug-in module is space-saving and communicates independently of the architecture or fieldbus you use. An intuitive wizard simplifies commissioning.



Industry focus

The Liquiline Edge Module offers a comprehensive and location-independent overview of all measured values. It is ideal for measuring points that are difficult to access, such as in drinking water networks and sewer systems. Additionally, it is beneficial in the wastewater, food and beverage, utilities, and industrial water industries. With the Liquiline Edge Module, you can empower your field across all industries. It enables process optimization and cost savings through real-time monitoring from any location.





Wastewater

In wastewater applications, the Liquiline Edge Module CYY7 is a significant tool. It enhances wastewater sewer systems, pump stations, and plant operations through real-time monitoring. Due to labor shortage at the plants, saving time and resources has become increasingly important. Real-time monitoring negates the need to cover long distances to the measurement point. No matter where you are or which device you're using, you can now access your measured values from anywhere.

Sewer systems

Pump stations

Effluent line

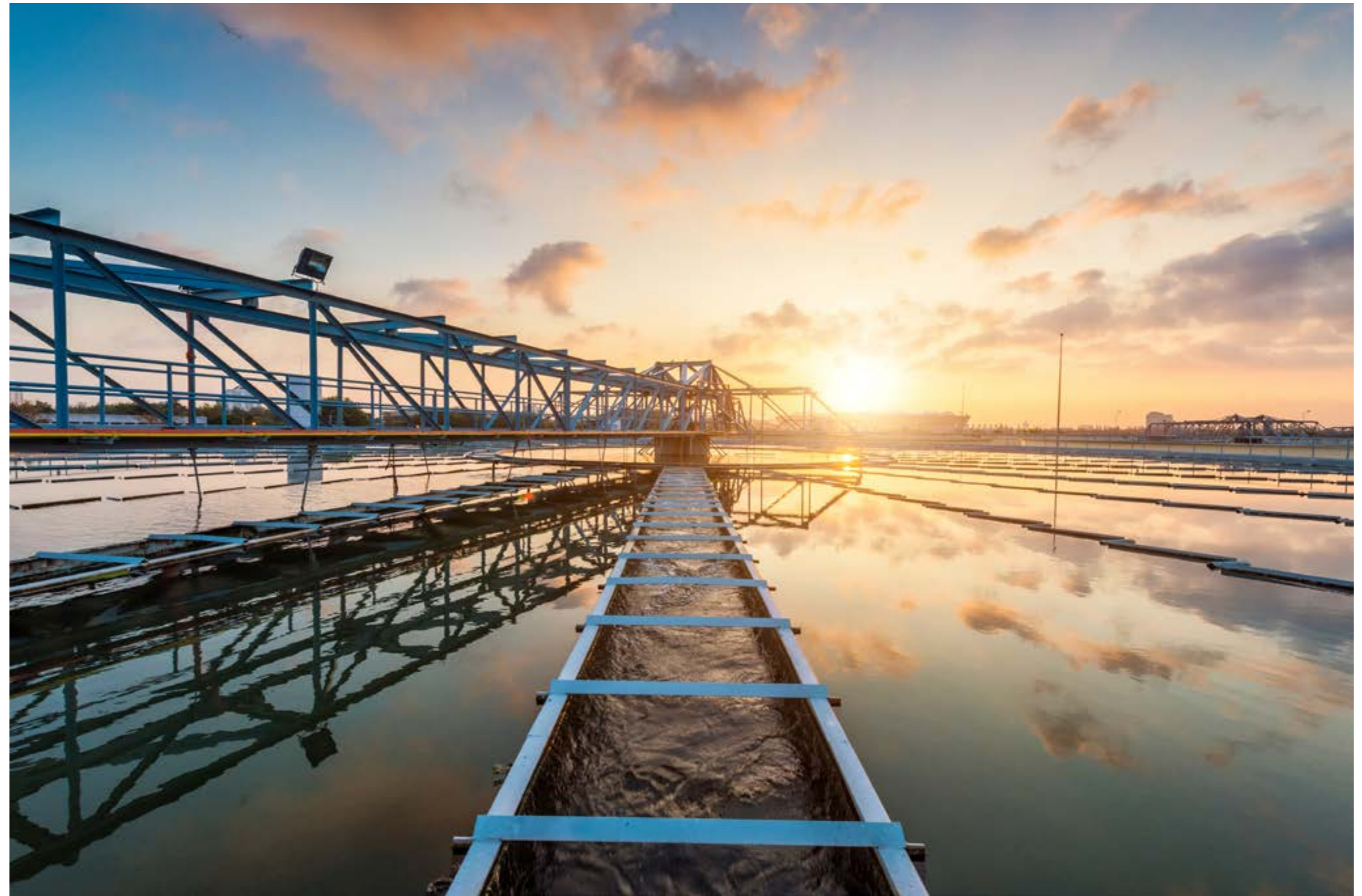



Water

In applications such as water abstraction, particularly for early warning monitoring and drinking water networks, the measurement points can often be difficult to access. With the Liquiline Edge Module, you can continuously monitor your measurements, enabling process optimization through early error detection.

Early warning monitoring

Abstraction

Drinking water distribution networks

Chlorination





Utilities & industrial water

In the field of utilities and industrial water, the integration of the Liquiline Edge Module ensures optimal water quality monitoring, enhancing real-time MRO insights. It aids in efficiently tracking and reducing water usage in energy processes, minimizing downtime with smart monitoring. Additionally, it allows for process optimization through early error detection.

Cooling water

Produced water in all industries





Food & Beverage

Prepare for digitalization and elevate your measurements in the Food & Beverage industry. Sustainability and efficient resource use are crucial in this sector. Our Liquiline Edge Module can enhance the productivity and safety of your processes. It allows for quick reactions and ensures consistent compliance with process standards through real-time monitoring.

Fish farming

Early detection of product losses

Quality monitoring of process water



Ecosystem: Netilion

From the measuring point to Netilion with the Liquiline Edge Module

The Liquiline Edge Module CYY7 establishes a connection to the Netilion cloud platform, without the need to modify the existing infrastructure. Via a separate communication channel, all relevant values are sent from the field device to the cloud. There, the data can be managed in various apps.

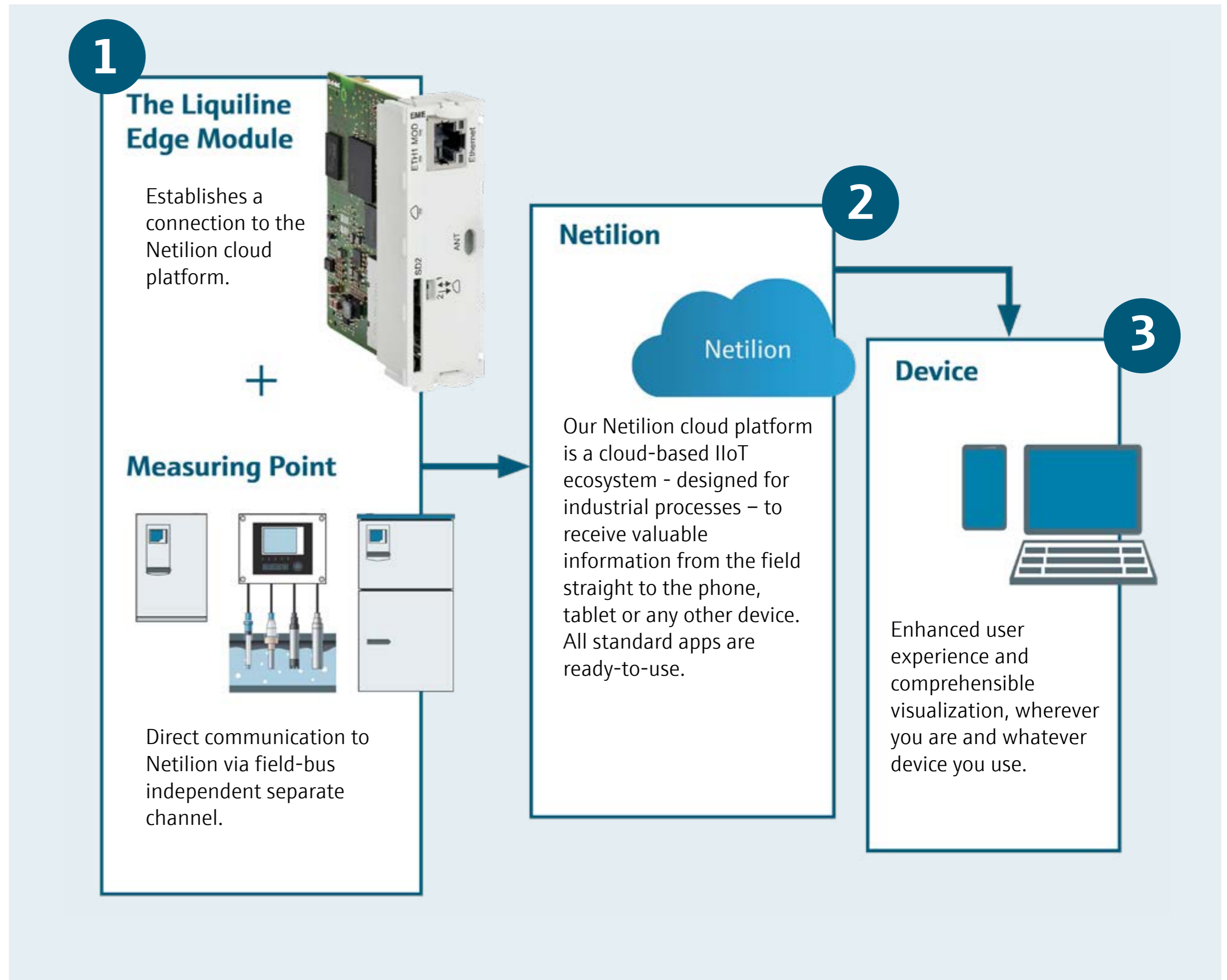



Digital services

Netilion is a web-based cloud system that seamlessly integrates every digital service you need for managing your plant assets and driving your digital transformation, all in one place. Our digital technologies fulfill internationally recognized standards and are certified by independent certification groups. Find out more about our set of powerful digital services.

Library

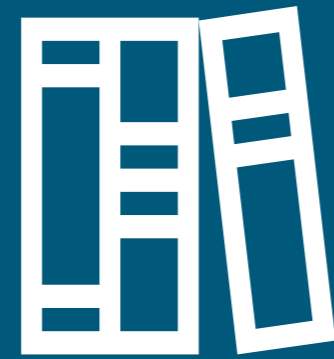

Netilion Library is an industrial file management service that saves and organizes working files and documents, helping people significantly save time searching for information.

Value



Netilion Value is an online monitoring service. Access your measurements at any time and from everywhere. Maximize productivity and increase responsiveness by being notified of any deviation in all kinds of applications.

Analytics



Netilion Analytics is a data analytics service that allows you to manage all assets and discover the potential for improvement in your plant.

Health



Netilion Health empowers maintenance teams to be ready and effective in case of unexpected events in your plants.

Assist



The Liquiline Assist App offers an enhanced user experience thanks to comprehensible visualization of liquid analysis measuring data and sensor health status. It also provides assistance in problem analysis and troubleshooting with state-of-the-art trend indications.

Security concept

For the use of the Liquiline Edge Module, an internet connection is mandatory. Due to communication beyond the operational technology, it is important to ensure that further security aspects are addressed. The Liquiline Edge Module fulfills the standardized security profile "ProtectBlue Security Gateway Basic." It provides a range of security mechanisms like Secure Boot, encrypted file system and encrypted https-connection with mTLS.

Additionally, the user can further restrict the communication between the Liquiline Edge Module and the respective field device. A mechanical switch on the cover of the module can be manually opened to disrupt the bidirectional communication between the field device and the edge module, thus preventing inbound communication from the cloud.

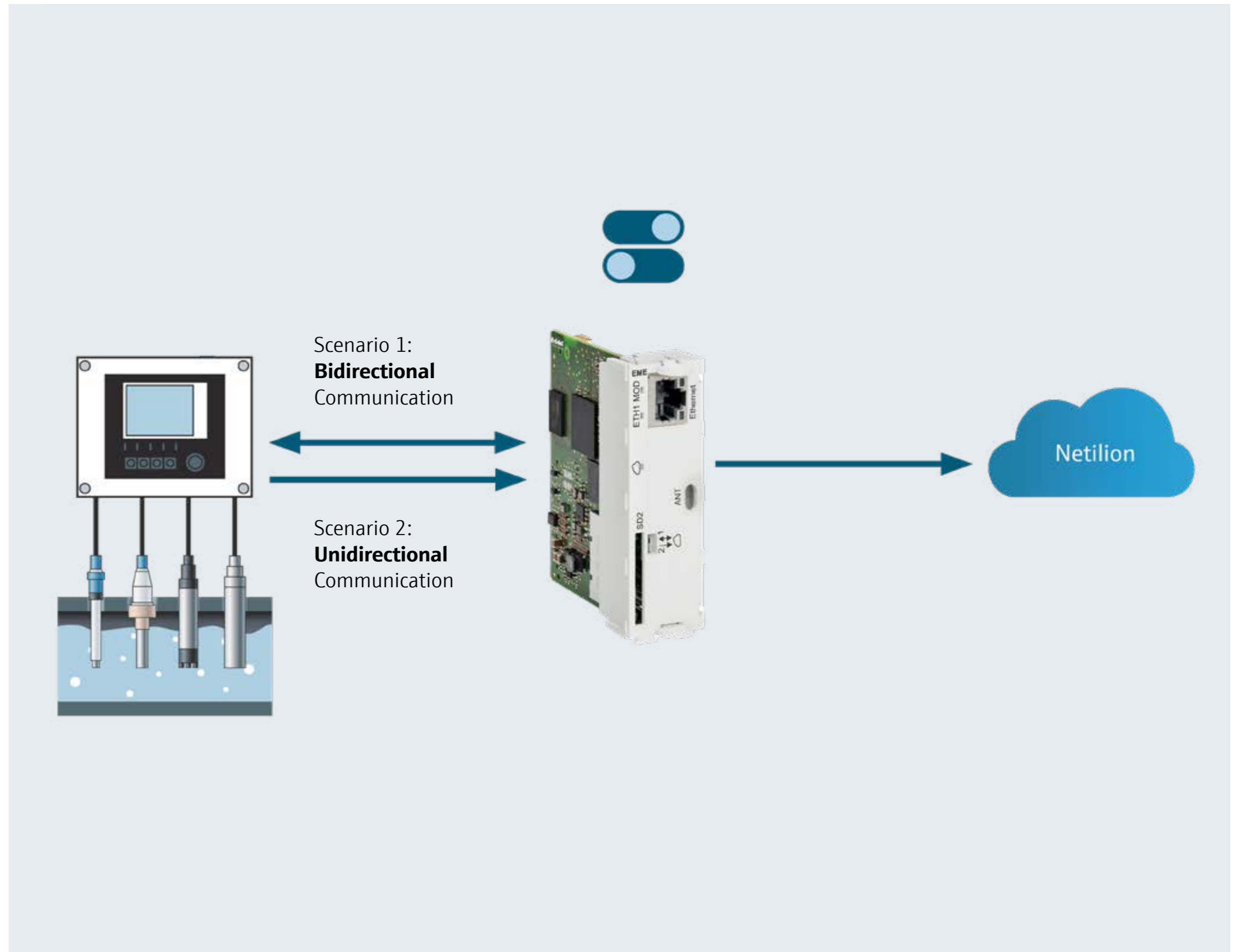

Product overview

You can integrate the Liquiline Edge Module CYY7 into your existing system or order them to be directly installed in your new product. It makes all Liquiline platform-based systems IIoT-ready. The module can be used with the new backplane, and the latest software version is required.



Upgrade your installed base



To upgrade your measuring point with the Liquiline Edge Module, simply order the kit from our website and insert it into your existing Liquiline platform-based system. The plug-in device is space-saving and communicates independently of whatever architecture and fieldbus system you use. An intuitive wizard simplifies commissioning.



New product within the Liquiline platform



Of course, you can not only upgrade your devices at a later date, but you can also order the Liquiline Edge Module directly as a feature and have it easily installed in your new transmitter, sampler, or analyzer. It can be ordered immediately as a new option through our website.

Technical data

Plug-in module available as radio or Ethernet variant

Extensive data can be transferred even from barely accessible measuring points, providing seamless connectivity to Netilion. This makes it the ideal connectivity solution for all plant infrastructures and remote locations.



Description	Connectivity solution for Liquiline platform
Operating System	Linux
Interfaces	1x RJ45 , 1x SD-card
Communication	<ul style="list-style-type: none"> ■ Ethernet (10/100 MBit/s) ■ LTE Cat M1 ■ Max. 375 kbps (download) ■ Max. 1.12 Mbps (upload) ■ Max. 32 kbps (download) ■ Max. 70 kbps (upload) ■ LTE Cat NB2 (NB-IoT) ■ Max. 136 kbps (download) ■ Max. 150 kbps (upload)
Mobile access	Internal eSim
Temperature	<ul style="list-style-type: none"> ■ Storage: -40 to +80 °C (-40 to +176 °F) ■ Operating mode: dep. on field device
Approval	Mandatory for module variant with cellular radio
Transmission interval	max. 15 minutes (please see Operating Instruction (BA) for details)
Data transmission	<ul style="list-style-type: none"> ■ Identification data ■ Current software version ■ Main measured values ■ Secondary measured values ■ Diagnostics ■ Logbook events ■ Field device health* ■ Sensor-Health*

*Requires activation of the Heartbeat Technology function in the field device



Two ways of communication

The radio and Ethernet variant

The module is available in two different variants: communication via Ethernet or cellular radio. The variant that suits you and your process best depends on your on-site infrastructure.



Radio

For customers without network infrastructure, the module comes with an additional antenna and cable, and supports LTE-M / NB-IoT technology

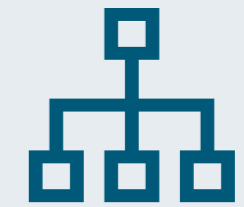

Ethernet

For customers that have a network infrastructure on site and are not allowed to use radio communication

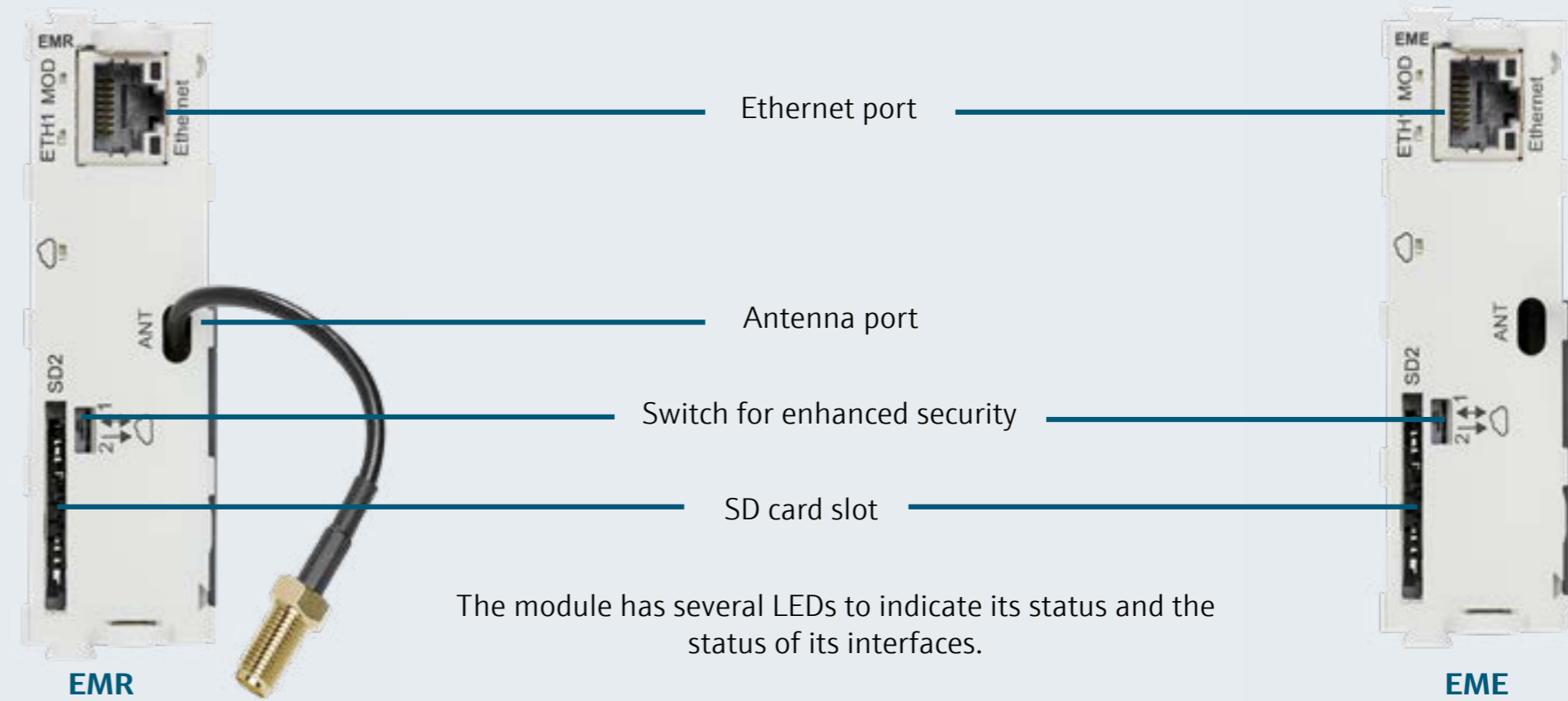

The module has several LEDs to indicate its status and the status of its interfaces.

Netilion-ready



Seamless integration

Make your Liquiline platform-based systems IIoT-ready

The Liquiline Edge Module is a key element that makes your Liquiline platform-based systems IIoT-ready. One of the outstanding features is its universal compatibility. Whether it's a transmitter, sampler, or analyzer, the module can be used without any problems with all products of the Liquiline platform. This means you can retrofit it into existing systems as well as integrate it into new products. Additionally, it is simple to install and integrate.



The **Liquiline Edge Module CYY7** makes all Liquiline platform-based systems **IIoT-ready**.

The module can be used with the **backplane from version 2** and the **latest software version** is required.

CM442/4/8/R

CSF34, CSF48

CA8x

Transmitters

Samplers

Analyzers

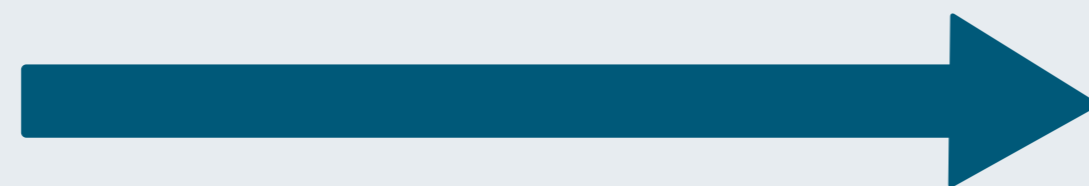

Liquiline platform

People for Process Automation

Discover the power of connectivity with our Liquiline Edge Module. Keep track of your measured values wherever you are and optimize your processes. With our easy plug-in module, you can facilitate your digital transformation and empower your field. Take the next step and discover how the Liquiline Edge Module can revolutionize your process.

Visit us on social media

