

Brief Operating Instructions

Liquiphant FailSafe FTL85

Vibronic
Level switch in liquids



These Brief Operating Instructions are not a substitute for the Operating Instructions pertaining to the device. Detailed information can be found in the Operating Instructions and the additional documentation.

Available for all device versions via:

- Internet: www.endress.com/deviceviewer
- Smartphone/tablet: Endress+Hauser Operations app

1 Related documents

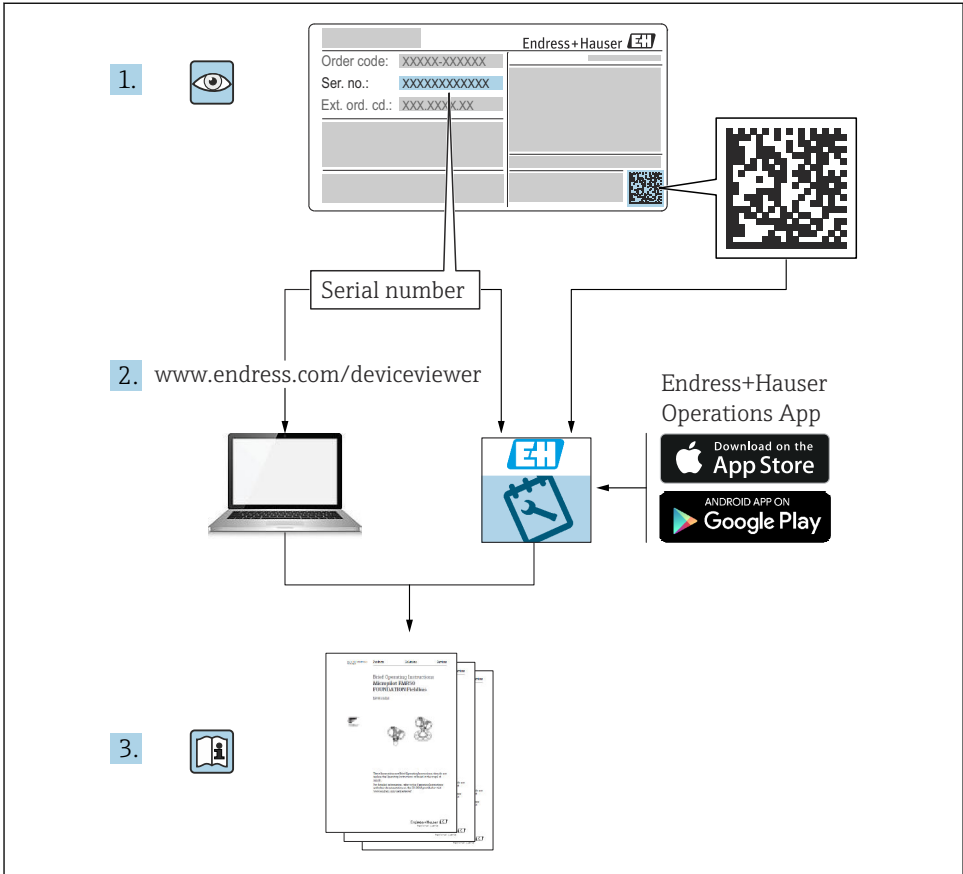

A0023555

2 About this document

2.1 Symbols

2.1.1 Warning symbols



This symbol alerts you to a dangerous situation. Failure to avoid this situation will result in serious or fatal injury.



This symbol alerts you to a dangerous situation. Failure to avoid this situation can result in serious or fatal injury.

CAUTION

This symbol alerts you to a dangerous situation. Failure to avoid this situation can result in minor or medium injury.

NOTICE

This symbol contains information on procedures and other facts which do not result in personal injury.

2.1.2 Electrical symbols

 Ground connection

Grounded clamp, which is grounded via a grounding system.

 Protective earth (PE)

Ground terminals, which must be grounded prior to establishing any other connections. The ground terminals are located on the inside and outside of the device.

2.1.3 Tool symbols

 Flat blade screwdriver

 Allen key

 Open-ended wrench

2.1.4 Symbols for certain types of information

 Permitted

Procedures, processes or actions that are permitted.

 Forbidden

Procedures, processes or actions that are forbidden.

 Tip

Indicates additional information

 Reference to documentation

 1., 2., 3.

Series of steps



Notice or individual step to be observed

2.1.5 Symbols in graphics

A, B, C ... View

1, 2, 3 ... Item numbers

 Hazardous area

 Safe area (non-hazardous area)

3 Basic safety instructions

3.1 Requirements for the personnel

The personnel must fulfill the following requirements to carry out the necessary tasks, e. g., commissioning and maintenance:

- ▶ Trained, qualified specialists must have a relevant qualification for the specific function and task
- ▶ Are authorized by the plant owner/operator
- ▶ Are familiar with federal/national regulations
- ▶ Must have read and understood the instructions in the manual and supplementary documentation
- ▶ Follow instructions and comply with conditions

3.2 Intended use

- Only use the device for liquids
- Improper use can pose hazards
- Ensure that the measuring device is free of defects while it is in operation
- Use the device only for media to which the wetted materials have an adequate level of resistance
- Do not exceed or drop below the relevant limit values for the device
 - ▣ For more details, see the Technical Documentation

3.2.1 Incorrect use

The manufacturer is not liable for damage caused by using the device incorrectly or for purposes for which it was not intended.

Residual risks

Due to heat transfer from the process, the temperature of the electronics housing and the assemblies contained therein may rise to 80 °C (176 °F) during operation.

Danger of burns from contact with surfaces!

- ▶ If necessary, ensure protection against contact to prevent burns.

3.3 Workplace safety

For work on and with the device:

- ▶ Wear the required personal protective equipment according to federal/national regulations.

3.4 Operational safety

Risk of injury!

- ▶ Operate the device only if it is in proper technical condition, free from errors and faults.
- ▶ The operator is responsible for ensuring the interference-free operation of the device.

Modifications to the device

Unauthorized modifications to the device are not permitted and can lead to unforeseeable dangers.

- ▶ If, despite this, modifications are required, consult with Endress+Hauser.

Repair

To ensure continued operational safety and reliability:

- ▶ Only perform repair work on the device if this is expressly permitted.
- ▶ Observe federal/national regulations pertaining to the repair of an electrical device.
- ▶ Use original spare parts and accessories from Endress+Hauser only.

Hazardous area

To eliminate danger to persons or the facility when the device is used in the hazardous area (e.g. explosion protection):

- ▶ Check the nameplate to verify whether the ordered device can be used for the intended purpose in the hazardous area.
- ▶ Observe the specifications in the separate supplementary documentation that is an integral part of this manual.

3.5 Product safety

This device is designed in accordance with good engineering practice to meet state-of-the-art safety requirements, has been tested, and left the factory in a condition in which it is safe to operate.

It meets the general safety standards and legal requirements. It also complies with the EU directives listed in the device-specific EU Declaration of Conformity. Endress+Hauser confirms this by affixing the CE mark to the device.

3.6 Functional safety SIL

The Functional Safety Manual must be strictly observed for devices that are used in functional safety applications.

3.7 IT security

We only provide a warranty if the device is installed and used as described in the Operating Instructions. The device has safety mechanisms integrated to prevent users from inadvertently changing settings.

Provide additional protection for the device and data transfer to/from the device

- ▶ IT security measures defined in the plant owner/operator's own security policy must be implemented by plant owners/operators themselves.

4 Incoming acceptance and product identification

4.1 Incoming acceptance

Check the following during incoming acceptance:

- Are the order codes on the delivery note and the product sticker identical?
- Are the goods undamaged?
- Do the data on the nameplate match the ordering information on the delivery note?
- If required (see nameplate): are the Safety Instructions e.g. XA provided?



If one of these conditions is not met, please contact the manufacturer's sales office.

4.2 Product identification

The device can be identified in the following ways:

- Nameplate specifications
- Extended order code with breakdown of the device features on the delivery note
- Enter serial number from nameplates in *W@M Device Viewer* www.endress.com/deviceviewer. All of the information on the measuring device is displayed along with an overview of the scope of technical documentation provided.
- Enter the serial number on the nameplate into the *Endress+Hauser Operations app* or scan the 2-D matrix code on the nameplate with the *Endress+Hauser Operations app*

4.2.1 Electronic insert



Identify the electronic insert via the order code on the nameplate.

4.2.2 Nameplate

The information that is required by law and is relevant to the device is shown on the nameplate.

4.2.3 Manufacturer address

Endress+Hauser SE+Co. KG
Hauptstraße 1
79689 Maulburg, Germany

Place of manufacture: See nameplate.

4.3 Storage and transport

4.3.1 Storage conditions

Use original packaging.

4.3.2 Storage temperature

-50 to +80 °C (-58 to +176 °F)

4.3.3 Transporting the device

- Transport the device to the measuring point in the original packaging
- Hold the device by the housing, temperature spacer, flange or extension pipe
- Do not hold the device by the vibrating fork!
- Do not bend, shorten or extend the vibrating fork.
- Follow the safety instructions and transport conditions for devices weighing more than 18 kg (39.6 lb) (IEC 61010).

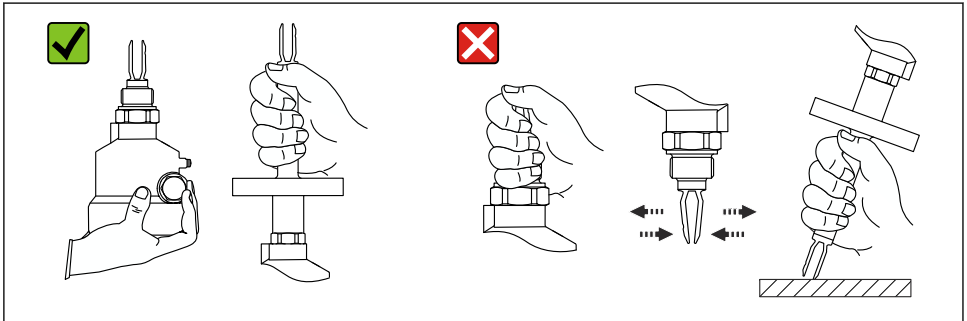

A0034846

1 Handling the device during transport

5 Installation

WARNING

Loss of protection rating if the device is opened in a wet environment.

- ▶ Only open the device in a dry environment!

Mounting instructions

- Any orientation for device with a pipe length of up to 500 mm (19.7 in) approx.
- Vertical orientation from above for device with long pipe
- Minimum distance between the tuning fork and the tank wall or pipe wall: 10 mm (0.39 in)

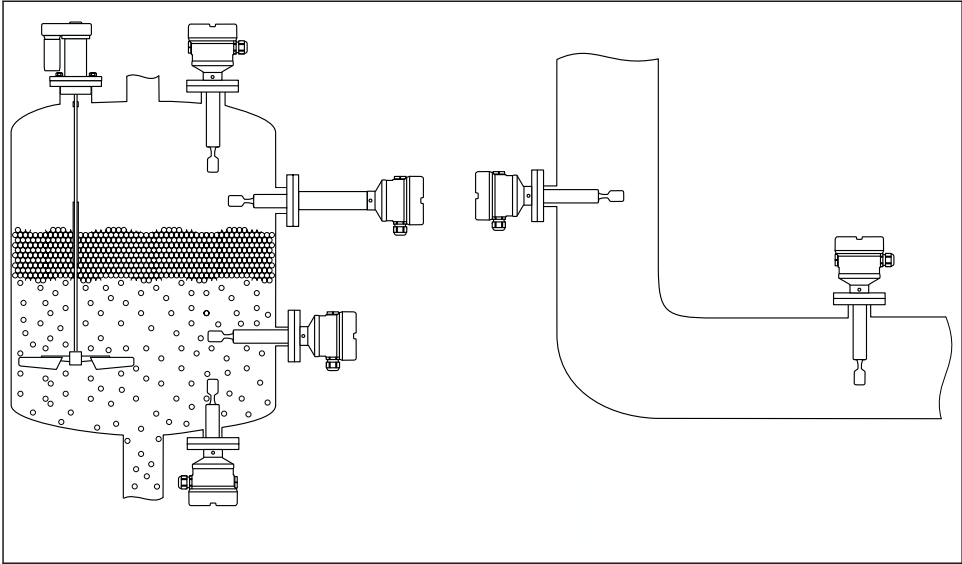

A0042153

2 Installation examples for a vessel, tank or pipe

5.1 Installation requirements

NOTICE

Scratches or impacts damage the coated surface of the device.

- Ensure the device is handled properly and professionally during all mounting work.

i In the case of sensors with an ECTFE or PFA coating, a PTFE seal is fixed on the flange.

5.1.1 Vessel with heat insulation

If process temperatures are high, the device should be incorporated in the usual vessel insulation system to prevent the electronics from heating as a result of thermal radiation or convection. The insulation in this case should not be higher than the neck of the device.

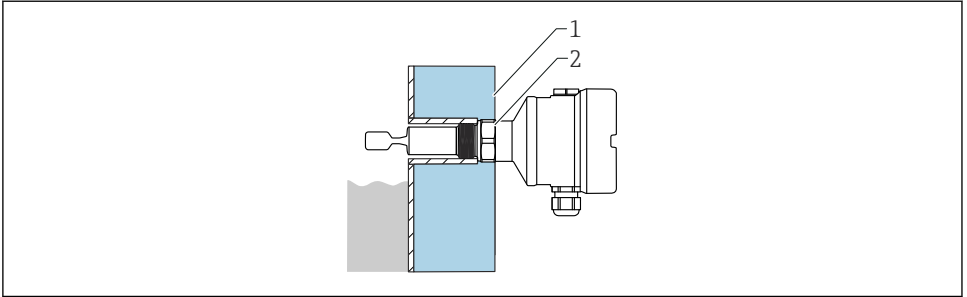

A0051616

3 Vessel with heat insulation (example)

- 1 Vessel insulation
- 2 Insulation up to the housing neck max.

5.1.2 Take switch point into consideration

The following are typical switch points, depending on the orientation of the level switch.

- i** Minimum distance between the tuning fork and the tank wall or pipe wall:
10 mm (0.39 in)

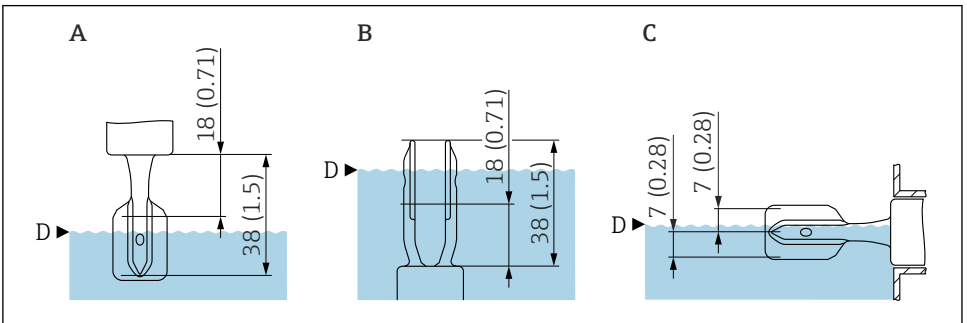

A0018008

4 Typical switch points

- A Installation from above
- B Installation from below
- C Installation from the side
- D Switch point (at reference operating conditions: 13 mm (0.51 in))

i Technical data of the reference operating conditions; see Operating Instructions and Technical Information.

i Outside the reference operating conditions, the switch point is in the area of the vibrating fork.

5.1.3 Viscosity depending on the mode of operation

i With regard to the viscosity of the medium, the restrictions for applications involved in safety-related operation must be observed, as specified in the Functional Safety Manual.

Align the vibrating fork so that the narrow sides of the vibrating fork point upwards and downwards, allowing the liquid to drain off properly.

Maximum detection: $\leq 10\,000 \text{ mPa}\cdot\text{s}$

Minimum detection: $\leq 350 \text{ mPa}\cdot\text{s}$

Minimum detection: coating 230 to 280 °C (450 to 536 °F) $\leq 100 \text{ mPa}\cdot\text{s}$

Low viscosity

i It is permitted to position the tuning fork within the installation socket.

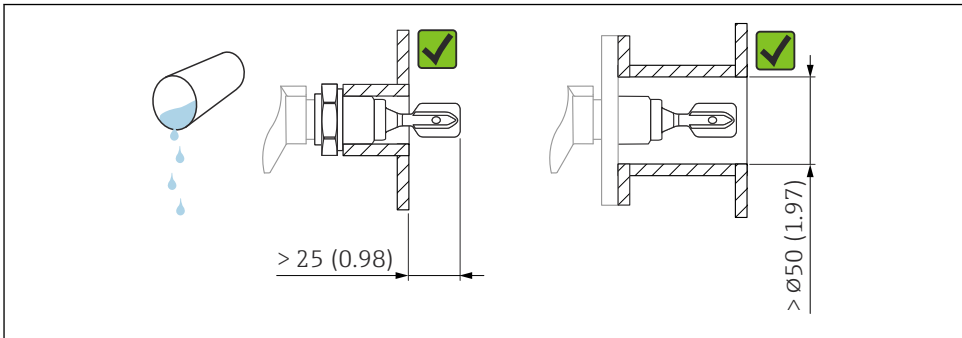

A0033297

5 Example of installation for low-viscosity liquids. Unit of measurement mm (in)

High viscosity

NOTICE

Highly viscous liquids may cause switching delays.

- ▶ Make sure that the liquid can run off the tuning fork easily.
- ▶ Deburr the socket surface.

i The tuning fork must be located outside the installation socket!

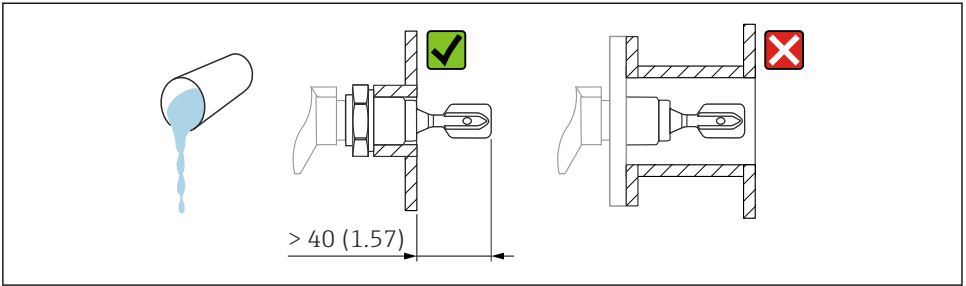

A0037346

6 Installation example for a highly viscous liquid. Unit of measurement mm (in)

5.1.4 Preventing buildup

NOTICE

Buildup formation can restrict applications during safety-related operation.

► Refer to the Functional Safety Manual.

Ensure that there is sufficient distance between the expected buildup on the tank wall and the fork.

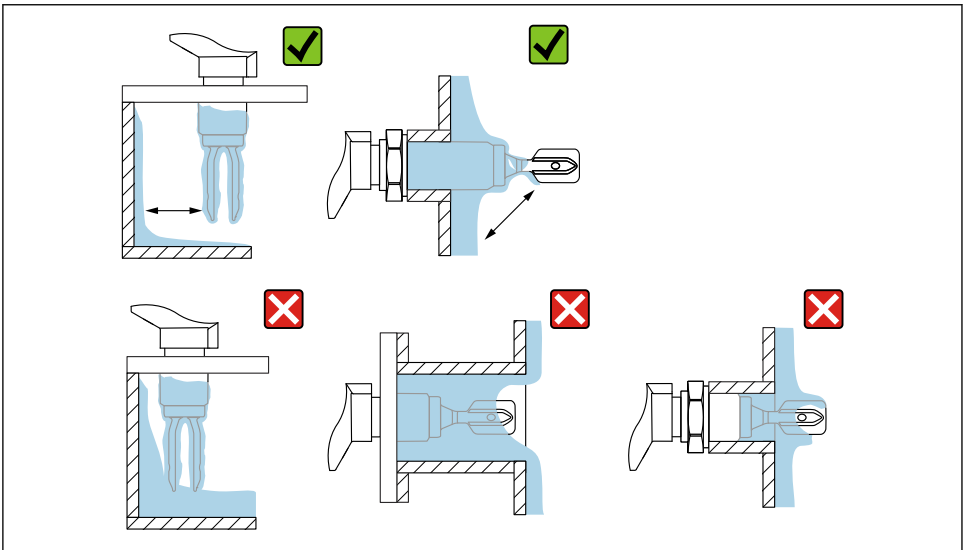

A0033239

7 Installation examples for a highly viscous process medium

5.1.5 Take clearance into consideration

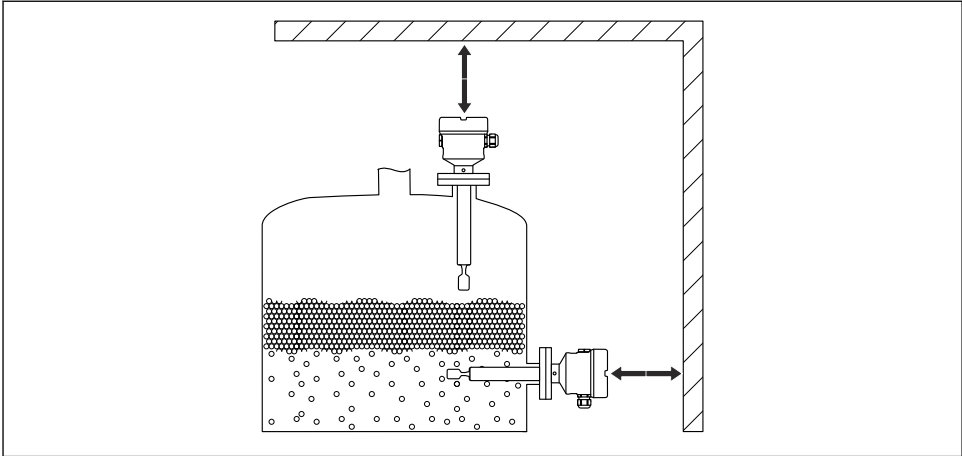

A0033236

 8 Take clearance outside the tank into consideration

5.1.6 Support the device

NOTICE

If the device is supported incorrectly, shocks and vibrations can damage the coated surface.

- ▶ Only use a support in conjunction with ECTFE or PFA plastic coating.
- ▶ Use suitable supports only.

Support the device in the event of severe dynamic load. Maximum lateral loading capacity of the pipe extensions and sensors: 75 Nm (55 lbf ft).

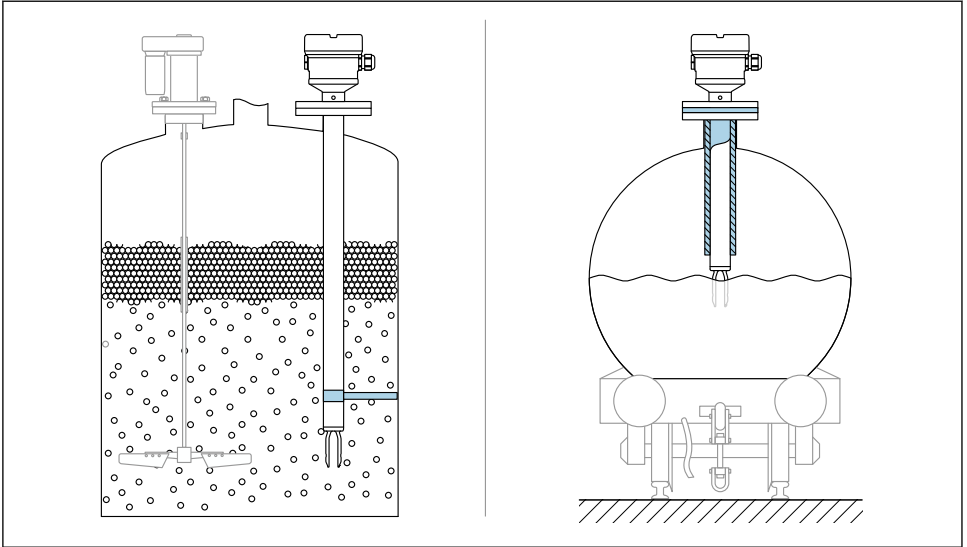

A0031874

9 Examples of support in the event of dynamic load

i Marine approval: In the case of pipe extensions or sensors longer than 1 600 mm (63 in), a support is needed at least every 1 600 mm (63 in).

5.2 Installing the device

5.2.1 Required tools

- Screw driver
- Open-ended wrench for sensor installation : SW32 or SW41
- Allen key for housing locking screw

5.2.2 Aligning the tuning fork using the marking

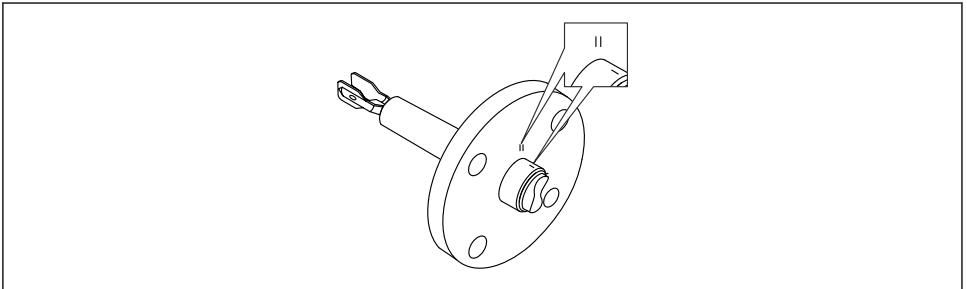

A0042207

10 Position of the tuning fork when installed horizontally in the vessel using the marking

5.2.3 Installing the device in piping

- Flow velocity up to 5 m/s with viscosity 1 mPa·s and density 1 g/cm³ (62.4 lb/ft³) (SGU).
Check for correct functioning in the event of other process medium conditions.
- If the vibrating fork is correctly aligned and the marking is pointing in the flow direction, the flow will not be significantly obstructed.
- The marking is visible when installed.
- Pipe diameter: ≥ 50 mm (2 in)

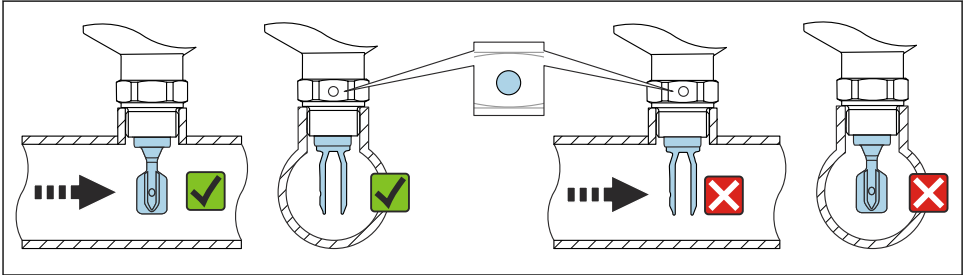

A0034851

11 Installation in pipes (take fork position and marking into consideration)

5.2.4 Screwing in the device

- Turn by the hex bolt only, 15 to 30 Nm (11 to 22 lbf ft)
- Do not turn using the housing.

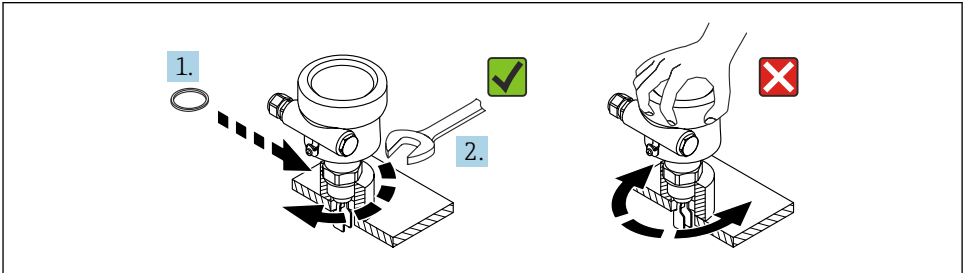

A0034852

12 Screwing in the device

5.2.5 Aligning the cable entry

For housing types F15 (316 L, hygienic), F27 (316 L)

The electronics housing can be aligned using an adjustment screw.

Aligning the housing:

1. Open the housing cover and loosen the adjustment screw.

2. Rotate the housing into the correct position.
3. Tighten the adjustment screw with maximum 0.9 Nm and close the housing cover.

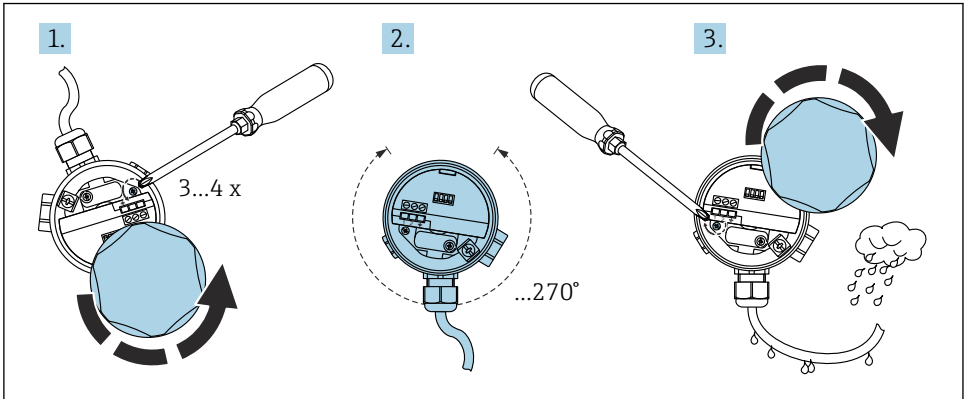

A0018018

For housing types F16 (plastic), F13, F17, T13 (aluminum)

The electronics housing can be manually aligned.

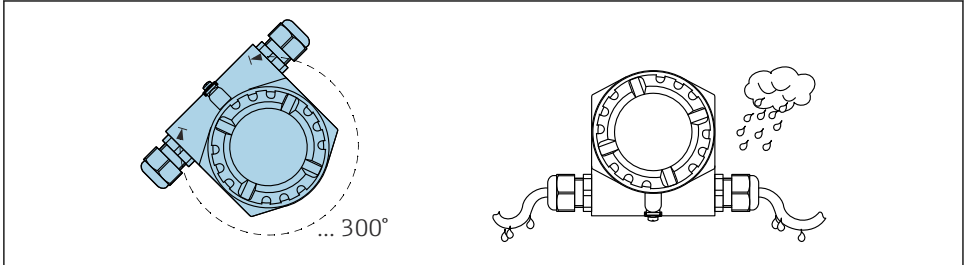

A0018022

5.2.6 Sealing the housing

NOTICE

Risk of device damage due to moisture inside the housing!

The O-ring seal on the housing cover can be destroyed by mineral oil-based grease. This can allow moisture to enter the housing.

- ▶ Use only an approved lubricant such as Syntheso Glep 1 for the O-ring seal on the housing cover.

NOTICE**Risk of device damage due to moisture inside the housing!**

An improperly closed housing cover or incorrectly sealed cable entries can allow moisture to enter the housing.

- ▶ Always ensure that the housing cover and cable entries are tightly closed.

5.2.7 Closing the housing covers**NOTICE****Thread and housing cover damaged from dirt and fouling!**

- ▶ Remove dirt (e.g. sand) on the thread of the covers and housing.
- ▶ If you continue to encounter resistance when closing the cover, check the thread again for fouling.

**Housing thread**

The threads of the electronics and connection compartment can be coated with an anti-friction coating.

The following applies for all housing materials:

- ✘ **Do not lubricate the housing threads.**

6 Electrical connection**NOTICE**

- ▶ Comply with national standards and regulations!

6.1 Required tool

- Screwdriver for electrical connection
- Allen key for screw of cover lock

6.2 Connecting protective earth (PE)

The protective earth conductor at the device must only be connected if the device's operating voltage is \geq AC 35 V or \geq DC 16 V.

When the device is used in hazardous areas, it must always be included in the potential equalization of the system, irrespective of the operating voltage.

6.3 Connecting the device**6.3.1 Power supply**

- Nominal supply voltage: DC 24 V
- Supply voltage range: DC 12 to 30 V
- Power consumption: < 660 mW
- Reverse polarity protection: yes

6.3.2 Connectable load

$$R = (U - 12 \text{ V}) / 22 \text{ mA}$$

U = Supply voltage range: DC 12 to 30 V

6.3.3 Galvanic isolation

- ▶ Ensure galvanic isolation between the sensor and power supply.

NOTICE

- ▶ The device must be connected to a power supply that provides sufficient isolation for the operating voltage.

6.3.4 Overvoltage protection

Overvoltage category II (DIN EN 60664-1 VDE 0110-1)

6.3.5 Pollution degree

Pollution degree 2 (IEC 60664-1 and IEC 61010-1)

6.3.6 Mode of operation

The minimum or maximum detection (MIN/MAX) is selected via the connection coding on the electronic insert.

MAX = maximum detection:

- The output switches in a safety-oriented manner when the probe is covered (demand mode).
- Used, for example, for overflow protection
- Jamming of the fork leads to a "covered" signal (demand mode)

MIN = minimum detection:

- The output switches in a safety-oriented manner when the probe is free (demand mode).
- Used, for example, for dry-run protection, pump protection
- Foam is not detected

6.3.7 Connection via M12 plug connector



For MAX operating mode with an M12 plug connector, it is not necessary to open the housing for connection purposes.

M12 plug

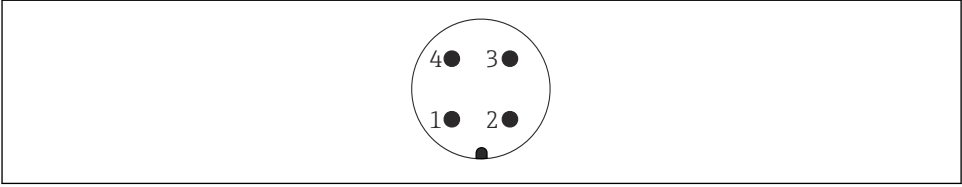

A0011175

13 M12 plug, pin assignment

- 1 Signal +
- 2 Not used
- 3 Signal -
- 4 Ground

FEL85 MAX operating mode (factory setting)

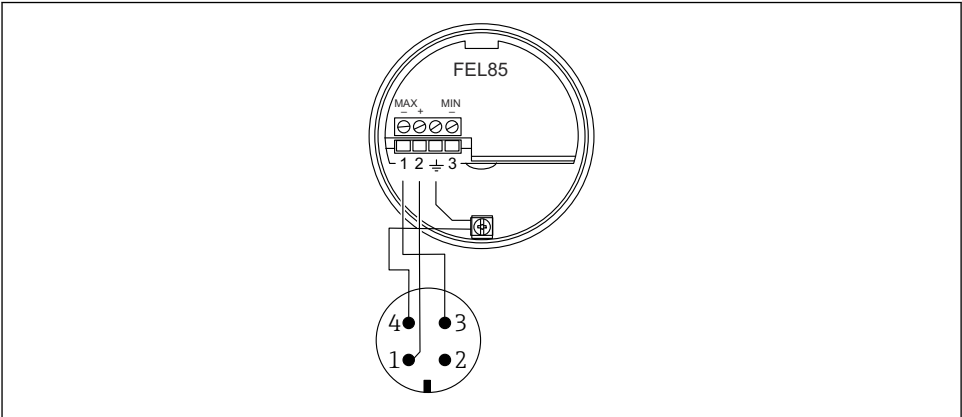

A0018026

14 Terminal assignment with M12 connector, MAX operating mode

FEL85 MIN operating mode

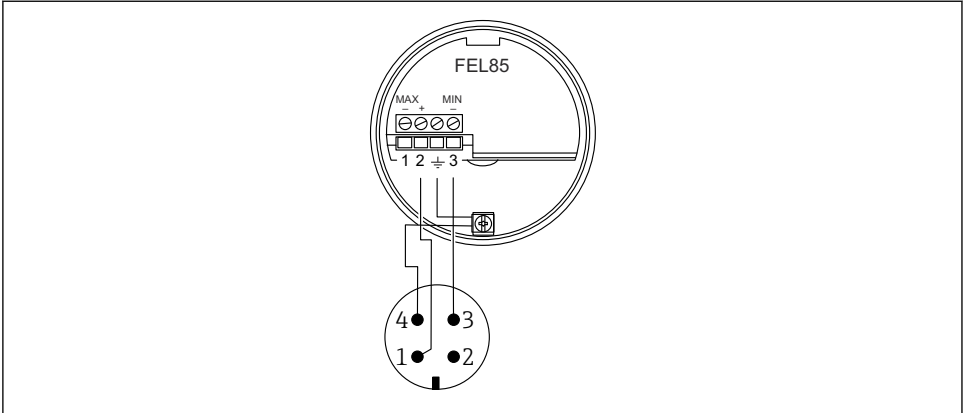

A0018028

 15 Terminal assignment with M12 connector, MIN operating mode

6.3.8 Connecting the cable

Required tools

- Flat-blade screwdriver (0.6 mm x 3.5 mm) for terminals
- Suitable tool with width across flats AF24/25 (8 Nm (5.9 lbf ft)) for M20 cable gland

Cable specification



The electronic inserts can be connected with commercially available instrument cables. If using shielded cables, it is recommended to connect the shielding on both sides for best results (if potential equalization is available).

Cable: maximum 25 Ω per conductor and 100 nF (typically 1 000 m (3 281 ft)).

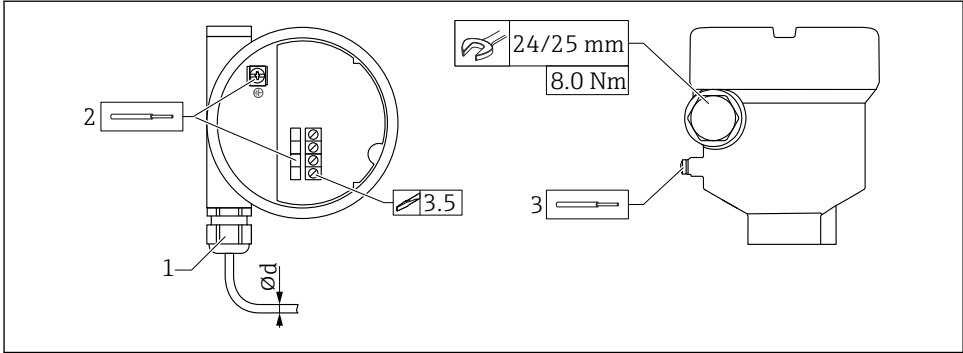

16 Example of coupling with cable entry, electronic insert with terminals

- 1 M20 coupling (with cable entry)
 - 2 Maximum conductor cross-section 2.5 mm^2 (AWG14), ground terminal inside the housing + terminals on the electronics
 - 3 Maximum conductor cross-section 4.0 mm^2 (AWG12), ground terminal outside the housing
- ∅d Cable gland, plastic 5 to 10 mm (0.2 to 0.38 in)
 Cable gland, nickel-plated brass 7 to 10.5 mm (0.28 to 0.41 in)
 Cable gland, stainless steel 7 to 12 mm (0.28 to 0.47 in)

i Pay attention to the following when using the M20 coupling

After inserting the cable:

- Counter-tighten the coupling.
- Tighten the union nut of the coupling with a torque of 8 Nm (5.9 lbf ft)
- Screw the enclosed coupling into the housing with a torque of 3.75 Nm (2.76 lbf ft)

6.3.9 Connection to the Nivotester FailSafe FTL825

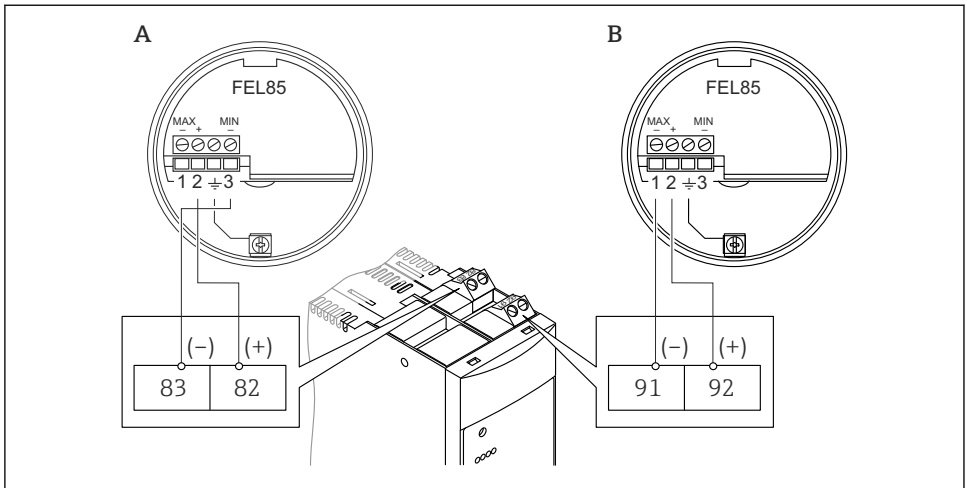

A0018029

A Minimum detection (dry-run protection)

B Maximum detection (overflow protection)

6.4 Connection to control systems

The device is suitable for connection to a programmable logic controller (PLC), a safety PLC (SPLC) or AI Modules via a 4 to 20 mA signal according to EN 61131-2 and NEO6, NEO43.

In the OK status (MIN covered/MAX free), the current output is within a range of 12 mA and 20 mA (MIN: 18.5 mA or MAX: 13.5 mA). Two different current ranges are used.

- Minimum detection (MIN): 17.5 to 19.5 mA
- Maximum detection (MAX): 12.5 to 14.5 mA



- To achieve SIL3, the current values must be monitored during integration into a PLC. A current value outside the current range is invalid (demand mode).
- For SIL1 or SIL2 applications, it is sufficient to program a current threshold of 12 mA.
- Demand mode: < 12 mA (MIN free/MAX covered)
- OK status: > 12 mA (MIN covered/MAX free)

Additionally, the LIVE signal permanently sent by the device can be monitored by the PLC. This is a square wave signal modulated onto the OK status (MIN: 18.5 mA or MAX: 13.5 mA) at 12.5 Hz with an amplitude of ± 0.5 mA (the signal changes by 1 mA every 2 000 ms).

This ensures that the sensor is correctly connected. The LIVE signal may also be used to detect faults in downstream components (PLC).

In demand mode (MIN free/MAX covered), the current output is within a range of 4 mA and 12 mA (MIN: 9 mA or MAX: 6 mA). Two different current ranges are used:

- Minimum detection (MIN): 8.0 to 10.0 mA
- Maximum detection (MAX): 5.0 to 7.0 mA

6.4.1 Device behavior in case of fault (alarm and warning)

In the event of a fault the current output is in the range below 3.6 mA. Short-circuits are an exception: in this case, the current output is in the range above 21 mA. For alarm monitoring, the logic unit must be able to detect both HI alarms (≥ 21.0 mA) and LO alarms (≤ 3.6 mA). No distinction is made between an alarm and a warning.

6.5 Ensuring the degree of protection

Tested in accordance with EN 60529 and NEMA 250

Housing

- Plastic (F16):
IP66/67/NEMA Type 4X enclosure
- 316L, hygienic (F15):
IP66/67/NEMA Type 4X enclosure
- 316L (F27):
IP66/68/NEMA Type 4X/6P enclosure
- Aluminium (F17):
IP66/67/NEMA Type 4X enclosure
- Aluminium (F13):
IP66/68/NEMA Type 4X/6P enclosure
- Aluminum (T13) with separate terminal compartment (Ex d):
IP66/68/NEMA Type 4X/6P enclosure

7 Operation options

7.1 Operation concept

- Operation with button and rotary switches on the electronic insert
- MIN or MAX detection via wiring configuration
- Density range adjustment via two rotary switches, confirmation via test button

7.2 Elements on the electronic insert

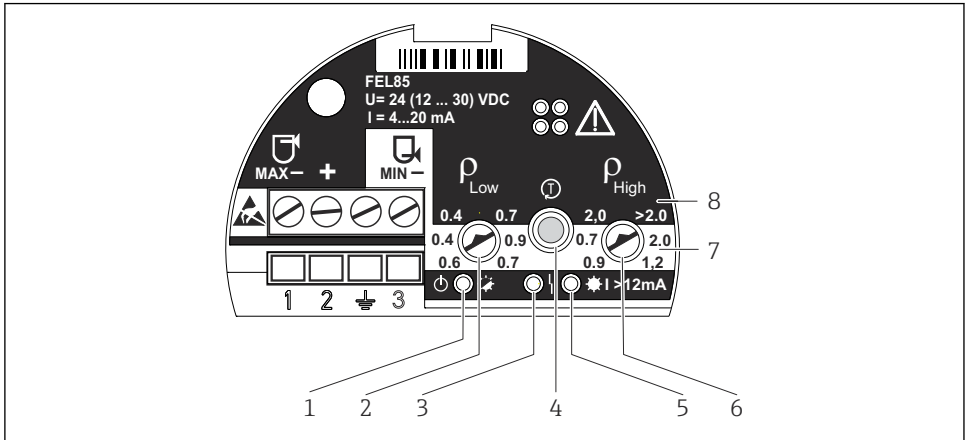

A0018032

- 1 Green LED, operation; initialization (lit), normal operation (flashes), fault (off) or flashes alternately with red LED
- 2 Density ρ_{Low} (rotary switch); Adjusts the lower density range limit
- 3 Red LED, fault; sensor error (lit permanently), operating error and electronic insert fault (flashing)
- 4 Test button; used to confirm configuration changes and activate proof testing
- 5 Yellow LED, current output; MAX (free) lit (13.5 mA), MIN (covered) lit (18.5 mA)
- 6 Density ρ_{High} (rotary switch); Adjusts the upper density range limit
- 7 MIN; white background indicates the adjustable density range in MIN detection mode
- 8 MAX; black background indicates the adjustable density range in MAX detection mode

8 Commissioning

NOTICE

- ▶ The operating mode (MIN or MAX detection) is set via the wiring configuration.
- ▶ The device is not operational in its delivery state. The density range must be set in order to commission the device. Otherwise the device starts with an error message.



For applications requiring functional safety in accordance with IEC 61508 (SIL), refer to the Functional Safety Manual.

8.1 Function check

See Operating Instructions.

8.2 Setting the density range

- ▶ Select the density ranges for low and high densities based on the media group (e.g. liquefied gas, alcohol, aqueous solutions, acid) on the device; see Operating Instructions.

WARNING

If the rotary switches are not aligned parallel to each other, no valid density range is selected.

The red LED flashes alternately with the green LED.

- ▶ Set the density range correctly.

8.2.1 Sensor pass

The sensor pass is a plug-in card located inside the device housing.

1. Mark the selected density range on the sensor pass.
2. Store the sensor pass inside the housing.

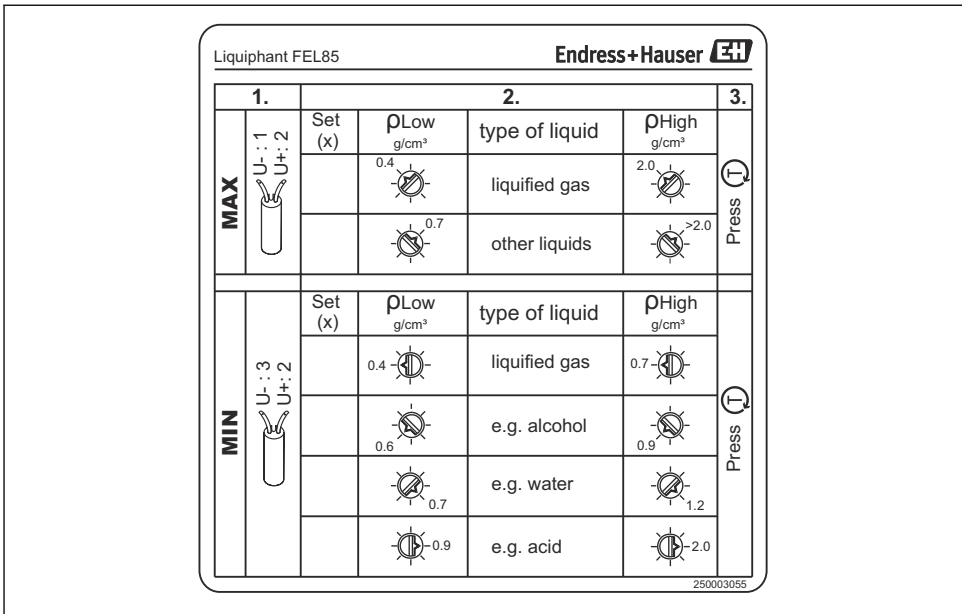

A0018034

Figure: sensor pass

8.3 Confirming configuration

Configuration confirmation is required. It can be performed in two ways:

- Press the test button on the device.
- Disconnect the device from the supply voltage (restart).

8.4 Proof testing

NOTICE

- ▶ Only start the function test in the OK status.
- ▶ For applications involved in safety-related operation, refer to the Functional Safety Manual.

The test button can be used to simulate the demand current. The output is set so that the currents of 6 mA(MAX) or 9 mA(MIN) are displayed.

Carry out the proof test:

1. Press the test button.
 - ↳ A limit alarm is triggered (MAX = 6 mA or MIN = 9 mA)
2. Release the test button.
 - ↳ System restarts with ≤ 3.6 mA, followed by normal operation



For the proof testing sequence, see the Operating Instructions and Functional Safety Manual.

8.5 Switching on the device







When the power connection is switched on, the output is in a fault signal state. The device is ready for operation after a maximum of 4 s.

8.5.1 Behavior of switch output and signaling in OK status

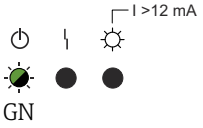
MIN	MAX
<p>$I > 12$ mA</p> <p>GN YE</p> <p>A0018047</p> <p> 18 LED signaling</p> <p>☀ = on ● = off ☀ = flashes</p>	<p>$I > 12$ mA</p> <p>GN YE</p> <p>A0018047</p> <p> 19 LED signaling</p> <p>☀ = on ● = off ☀ = flashes</p>
<p>+ 18.5 mA -</p> <p>2 3</p> <p>A0018048</p> <p> 20 Output signal</p>	<p>+ 13.5 mA -</p> <p>2 1</p> <p>A0018049</p> <p> 21 Output signal</p>

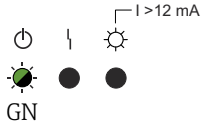
A permanent LIVE signal (frequency 0.25 Hz, amplitude ± 0.5 mA) is superimposed on the output signal in the OK status.

8.5.2 Behavior of the switch output and signaling in demand mode

MIN	MAX
 <p>GN</p> <p>A0057192</p> <p> 22 <i>LED signaling</i></p> <p>● = off ☀ = flashes</p>	 <p>GN</p> <p>A0057192</p> <p> 23 <i>LED signaling</i></p> <p>● = off ☀ = flashes</p>
<p>+ 9.0 mA -</p> <p>2 → 3</p> <p>A0018052</p> <p> 24 <i>Output signal</i></p>	<p>+ 6.0 mA -</p> <p>2 → 1</p> <p>A0018053</p> <p> 25 <i>Output signal</i></p>

8.6 Status of the outputs in the event of an error

In the event of an error, the output current I is < 3.6 mA (failure current in accordance with NAMUR NE43).



For troubleshooting and fault resolution, see the Operating Instructions.

8.7 Further information



Further information and currently available documentation can be found on the Endress+Hauser website: www.endress.com → Downloads.



71695943

www.addresses.endress.com
