

사용 설명서
Liquiphant S FTL70/71 - #####7##

KO- 포인트 레벨 스위치

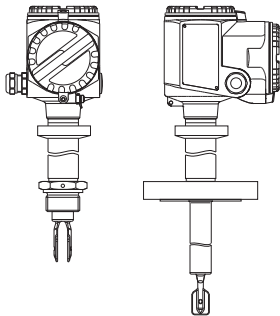

KO 목차

안전 지침	3
취급	4
기기 식별	6
용도	12
측정 시스템	13
설치	17
설정	26
점등 신호	31
연결	32
유지보수, 세척	54
기술 데이터	55
액세서리	57
문제 해결	60
예비 부품	62
수리	64
참고 자료	65



X 주의!

= 금지됨.

잘못된 작동이나 파손을
유발할 수 있습니다.

KO-안전 지침

Liquiphant S FTL70, FTL71

은 유체의 포인트 레벨 검출에 사용하는 기기입니다.

잘못 사용하면 위험한 상황이 발생할 수 있습니다.

레벨 제한 스위치

Liquiphant S FTL70, FTL71 의

설치, 연결, 시운전, 작동 및 유지보수는 본 사용 설명서, 관련 표준, 법적 규정 및 인증에 따라 **공인 전문가**만 수행할 수 있습니다.

기기 근처에 쉽게 접근할 수 있는 전원 스위치를 설치하십시오.
전원 스위치를 기기의 차단기로 표시하십시오.

KO-취급

취급 시 온도 스페이서나
플랜지, 익스텐션 튜브 부분을
이용해 잡으십시오.

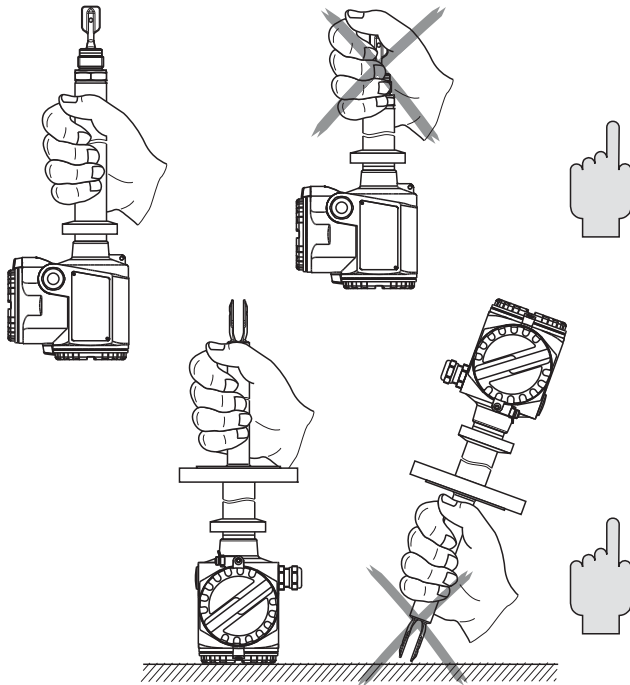

**KO-구부리지 마십시오.
줄이지 마십시오.
연장하지 마십시오.**

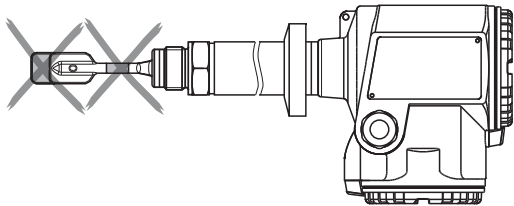
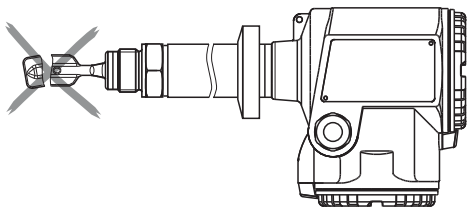
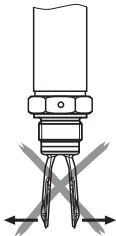
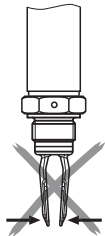

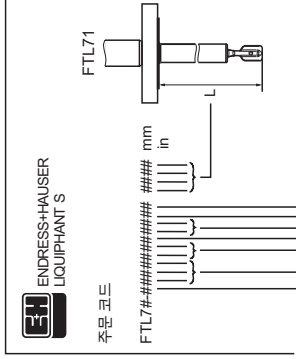

ENDRESS+HAUSER
LIQUIPHANT S

주문 코드

FTL71##### mm in

FTL71

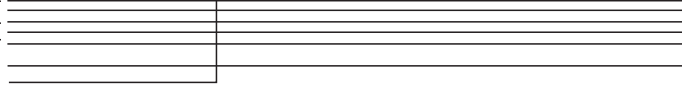

A	*	ATEX II 3 G, EEx nC, II T6, WHG
B		ATEX II 3 D T85°C ³
C		ATEX II 3 G, EEx nA II T6, WHG
		ATEX II 3 D T85°C ³
D	*	WHG
E		ATEX II 1/2 G, EEx de IIC T6, WHG
F		ATEX II 1/2 G, EEx ia IIC T6, WHG
		ATEX II 1/2 D T80°C ³
L		ATEX II 1/2 G, EEx d IIC T6, WHG
M		NEPSI Ex ia IIC T6
N		NEPSI Ex d IIC T6
P		FM, IS, Cl. I, II, III, Div. 1, Gr. A-G
Q		FM, XP, Cl. I, II, III, Div. 1, Gr. B-G, E5 => Gr. A-G
R		FM, NI, Cl. I, Div. 2, Gr. A-D
S		CSA, IS, Cl. I, II, III, Div. 1, Gr. A-G
T		CSA, XP, Cl. I, II, III, Div. 1, Gr. A-G
U		CSA, 범용
V		TIIS Ex ia IIC T2
W		TIIS Ex d IIC T2
Y	*	

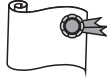



A##
B##
C##
D##
K##

플랜지

12 13

GE2 R 3/4, DIN 2999, 316L
 GE5 R 3/4, DIN 2999, AlloyC4
 GE6 R 3/4, DIN 2999, AlloyC22
 GF2 R 1, DIN 2999, 316L
 GF5 R 1, DIN 2999, AlloyC4
 GF6 R 1, DIN 2999, AlloyC22
 GM2 NPT 3/4, ANSI, 316L
 GM5 NPT 3/4, ANSI, AlloyC4
 GM6 NPT 3/4, ANSI, AlloyC22
 GN2 NPT 1, ANSI, 316L
 GN5 NPT 1, ANSI, AlloyC4
 GN6 NPT 1, ANSI, AlloyC22
 GQ2 G 3/4, ISO 228, 316L
 GQ5 G 3/4, ISO 228, AlloyC4
 GQ6 G 3/4, ISO 228, AlloyC22
 GR2 G 1, ISO 228, 316L
 GR5 G 1, ISO 228, AlloyC4
 GR6 G 1, ISO 228, AlloyC22



max. 64 bar, 280 °C
 max. 100 bar, 260 °C



max. 64 bar, 280 °C
 max. 100 bar, 260 °C

YY9

10 11

* 1 없음

* 2 기타

* 3 PBT는 해당 없음



ENDRESS+HAUSER
LIQUIPHANT S

주문 코드

FTL 7#-#####

mm

in

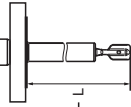

FTL 71

#####

mm

in

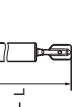

FTL70:

AB^{*2}

316L*, 318L**, Ra < 3,2 µm/80 grit

AE^{*2}

AlloyC4*+**, Ra < 3,2 µm/80 grit

FTL71:

BB

316L*, 318L**, Ra < 3,2 µm/80 grit

BE

AlloyC4*+**, Ra < 3,2 µm/80 grit

CB

316L*, 318L**, Ra < 3,2 µm/80 grit

CE

AlloyC4*+**, Ra < 3,2 µm/80 grit

YY^{*2}

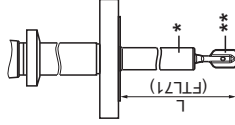

FEL50A, PROFIBUS PA

A

19...253 V AC

1

55 V DC, PNP

2

19...55 V DC, DPDT

4

11... 36 V DC, 8/16 mA

5

NAMUR, L-H

6

NAMUR, H-L

7

+ 테스트 버튼

8

9^{*2}



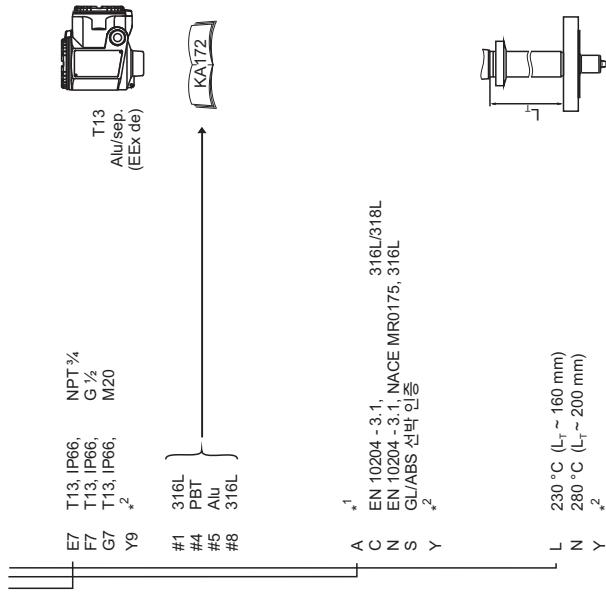

¹ 없음

² 기타

ANSI B16.5

AB2 1 1/4"	300 lbs, RF, 316/316L
AC2 1 1/2"	150 lbs, RF, 316/316L
AD2 1 1/2"	300 lbs, RF, 316/316L
AE2 2"	150 lbs, RF, 316/316L
AE5 2"	150 lbs, AlloyC4 > 1.4462
AE6 2"	150 lbs, AlloyC22 > 1.4462
AF2 2"	300 lbs, RF, 316/316L
AF5 2"	300 lbs, AlloyC4 > 1.4462
AF6 2"	300 lbs, AlloyC22 > 1.4462
AG2 2"	600 lbs, RF, 316/316L
AG5 2"	600 lbs, AlloyC4 > 1.4462
AG6 2"	600 lbs, AlloyC22 > 1.4462
AL2 3"	150 lbs, RF, 316/316L
AM2 3"	300 lbs, RF, 316/316L
AN2 3"	600 lbs, RF, 316/316L
AN5 3"	600 lbs, AlloyC4 > 1.4462
AN6 3"	600 lbs, AlloyC22 > 1.4462
AP2 4"	150 lbs, RF, 316/316L
AQ2 4"	300 lbs, RF, 316/316L
AR2 4"	600 lbs, RF, 316/316L
AB2 1"	150 lbs, RF, 316/316L

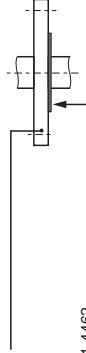

EN 1092-1

BB2 DN32,	PN25/40 A, 316L
BD2 DN40,	PN25/40 A, 316L
BG2 DN50,	PN25/40 A, 316L
BI2 DN50,	PN63 A, 316L
BJ2 DN50,	PN100 A, 316L
BK2 DN65,	PN25/40 A, 316L
BN2 DN80,	PN25/40 A, 316L
BR2 DN100,	PN25/40 A, 316L
BU2 DN100,	PN63 A, 316L
B02 DN80,	PN63 A, 316Ti
B12 DN80,	PN100 A, 316L
B82 DN25,	PN25/40 A, 316L

CF2	DN50,	PN10/16 B1, 316L
CG2	DN50,	PN25/40 B1, 316L
CG5	DN50,	PN25/40, AlloyC4 > 1.4462
CG6	DN50,	PN25/40, AlloyC22 > 1.4462
C12	DN50,	PN63 B2, 316L
C15	DN50,	PN63, AlloyC4 > 1.4462
C16	DN50,	PN63, AlloyC22 > 1.4462
CJ2	DN50,	PN100 B2, 316L
CM2	DN80,	PN10/16 B1, 316L
CN2	DN80,	PN25/40 B1, 316L
CN5	DN80,	PN25/40, AlloyC4 > 1.4462
CN6	DN80,	PN25/40, AlloyC22 > 1.4462
CQ2	DN100,	PN10/16 B1, 316L
CU2	DN100,	PN63 B2, 316L
CU5	DN100,	PN63, AlloyC4 > 1.4462
CU6	DN100,	PN63, AlloyC22 > 1.4462
C02	DN80,	PN63 B2, 316L
C05	DN80,	PN63, AlloyC4 > 1.4462
C06	DN80,	PN63, AlloyC22 > 1.4462
C12	DN80,	PN100 B2, 316L
C82	DN25,	PN25/40 B1, 316L
C85	DN25,	PN25/40, AlloyC4 > 1.4462
C86	DN25,	PN25/40, AlloyC22 > 1.4462
DG2	DN50,	PN40 B1, 316L
DIN2	DN80,	PN40 B1, 316L
D82	DN25,	PN40 B1, 316L

JIS B2220

KF2	20K 50, RF,	316L
KF5	20K 50, RF,	AlloyC4 > 316L
KF6	20K 50, RF,	AlloyC22 > 316L

KO-용도

유체의 포인트 레벨 검출

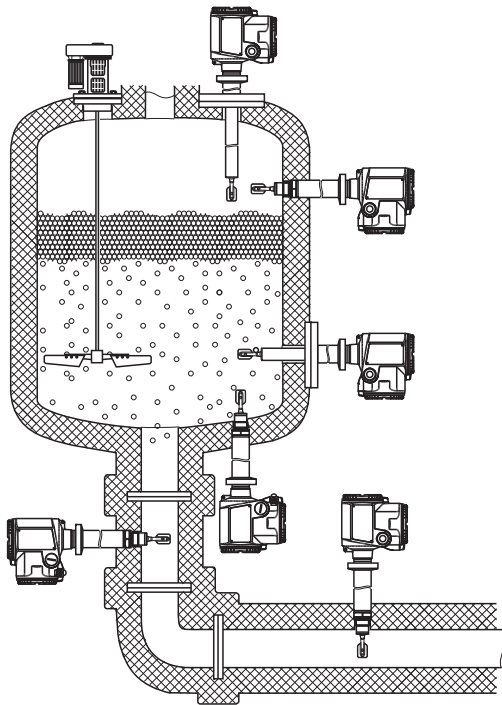

**KO-직접 연결용
측정 시스템**

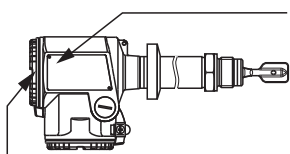

주문 코드:
FTL7# - # ### ## # ## ##

기판

FEL51
FEL52
FEL54

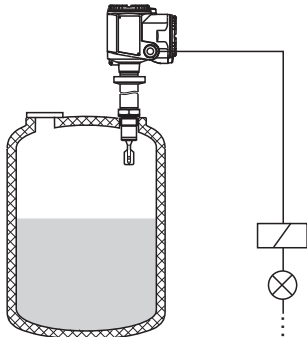

*)

*) 외부 부하

KO-스위칭 유닛 통해 연결하는
측정 시스템

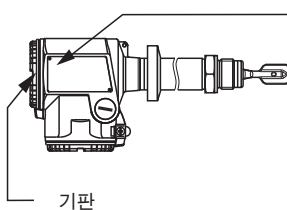

주문 코드:
FTL7# - # #### # # ##

FEL55
FEL56
FEL57
FEL58

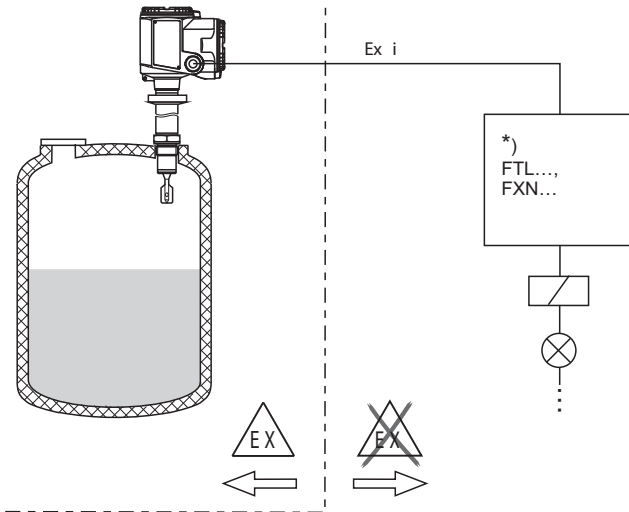

*) 스위칭 유닛, PLC, 절연 증폭기

KO-측정 시스템
PROFIBUS PA 연결용

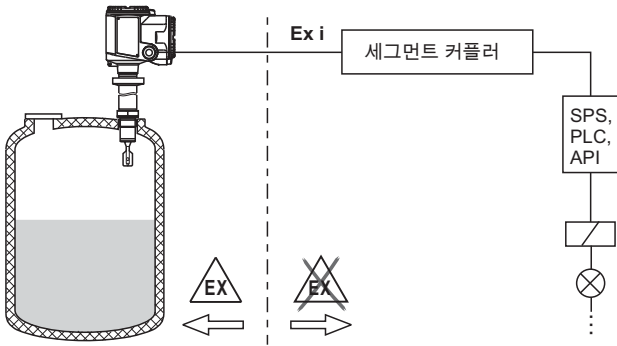
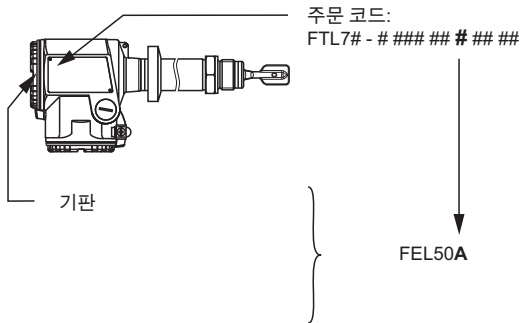

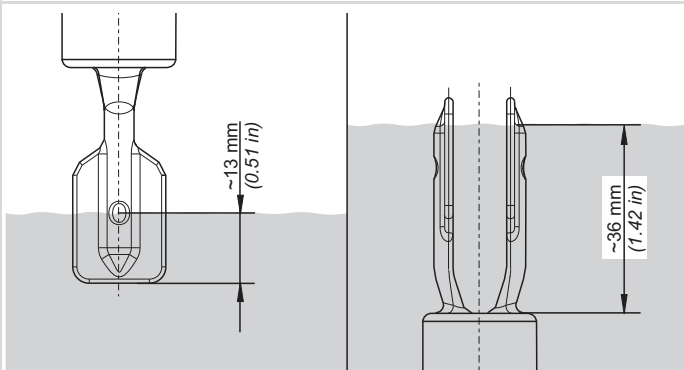

KO-설치

스위치 지점은 설치 위치에 따라 다름

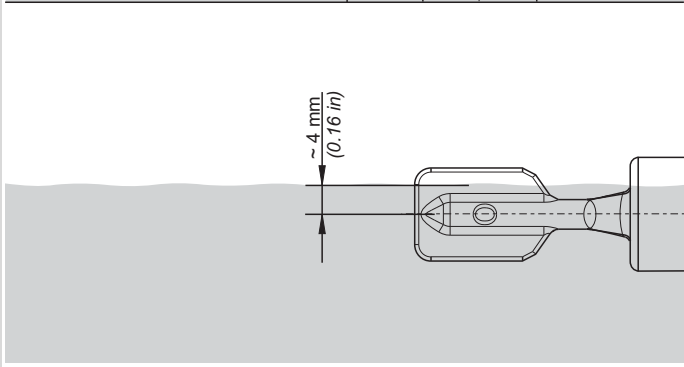

KO-유체 점도에 따른
설치 예시

$\nu = 0 \dots 2000 \text{ mm}^2/\text{s}$
($\nu = 0 \dots 2000 \text{ cSt}$)

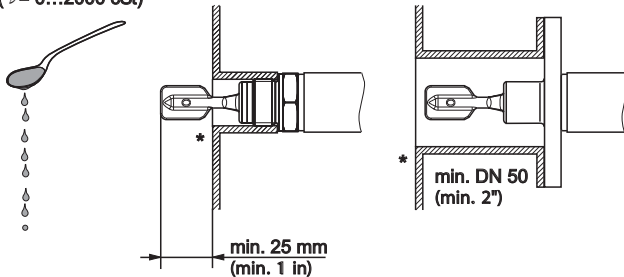

* 디버링

$\nu = 0 \dots 10000 \text{ mm}^2/\text{s}$
($\nu = 0 \dots 10000 \text{ cSt}$)

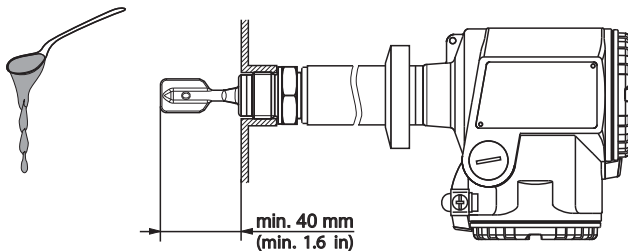

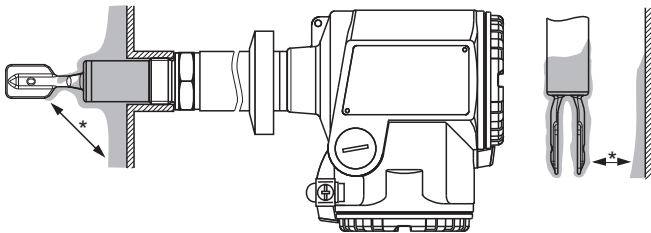

KO-유체 점착을 고려하십시오.
 포크가 점착된 유체에 닿으면
 안 됩니다.

* 거리!

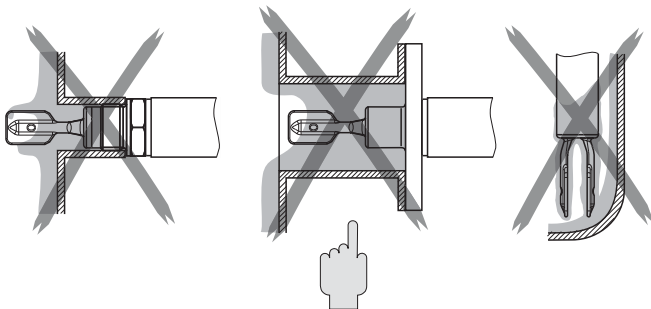

KO-동적 힘이 있는 경우 서포트를
설치하십시오.

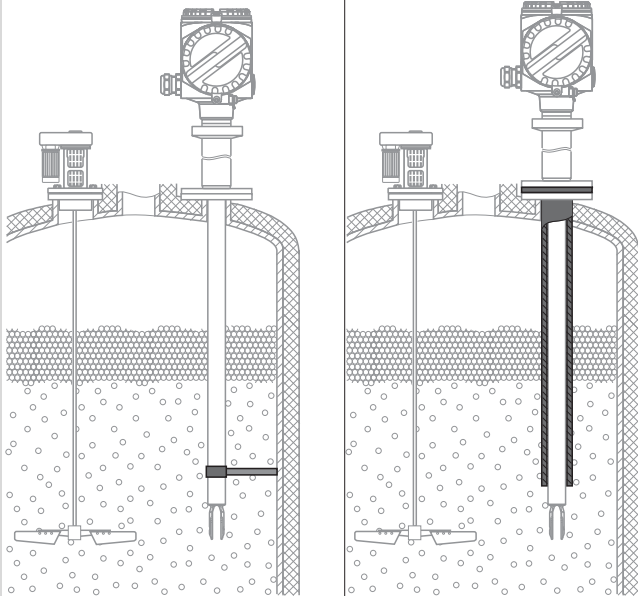

KO-간격을 유지하십시오.

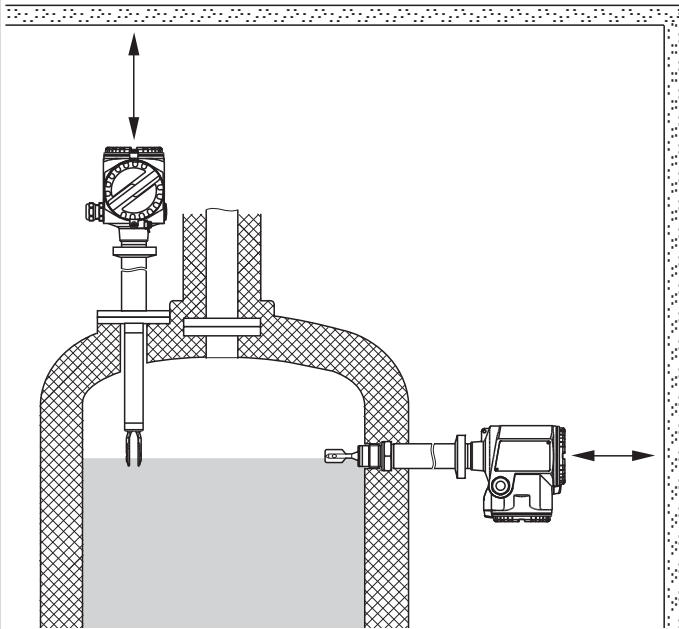

KO-포크 방향
마킹을 위나 아래로 향하도록
하십시오.

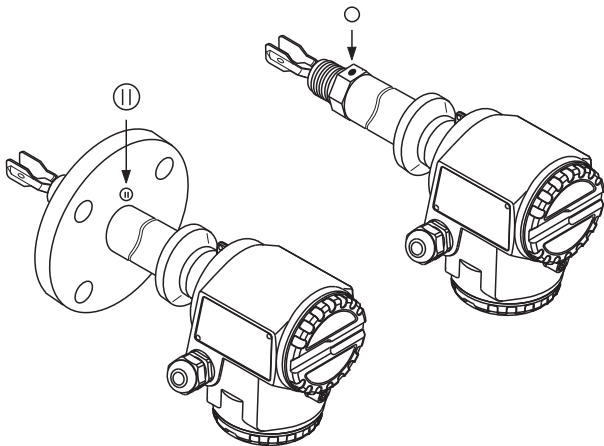
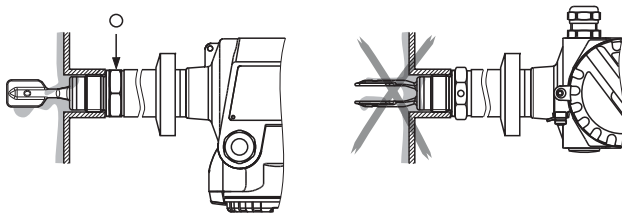

G ¾, 32 mm (1¼")*
G 1, 41 mm (1⅝")*

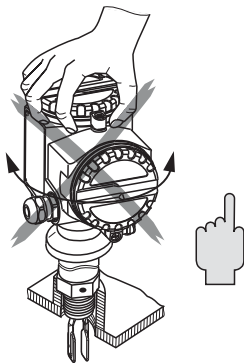
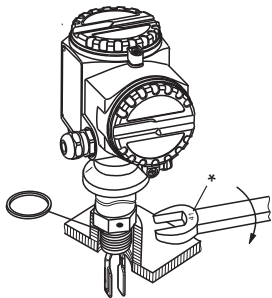

KO-Liquiphant 를 프로세스 연결부에
끼우십시오.
하우징을 돌리지 마십시오.

NPT ¾, R ¾, G ¾, 32 mm (1¼")*
NPT 1, R 1, G 1, 41 mm (1⅝")*

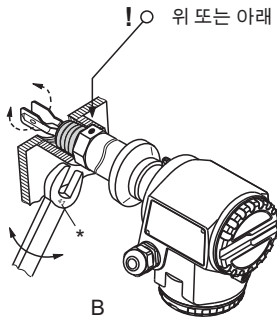
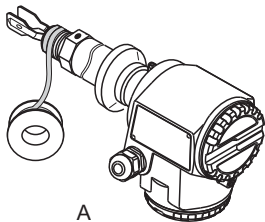

KO- 파이프에서의 설치 방향
 마킹을 유체 방향으로 향하도록
 하십시오.

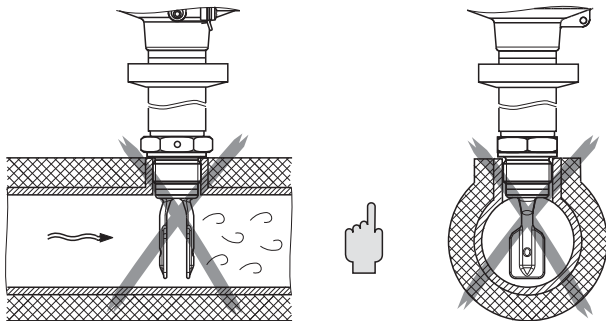
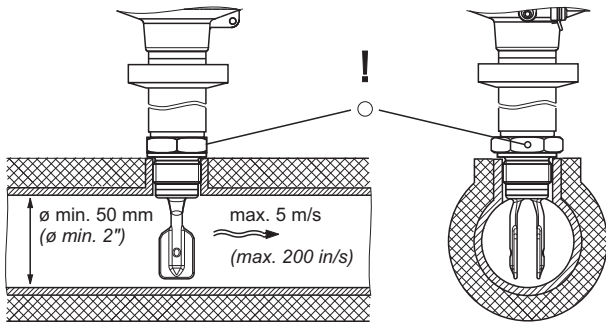

KO-케이블 그랜드 방향

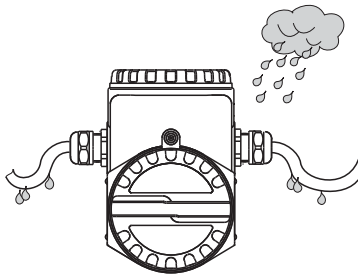
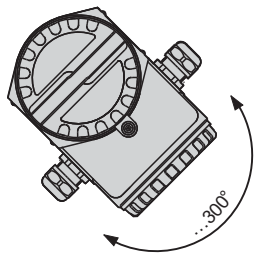
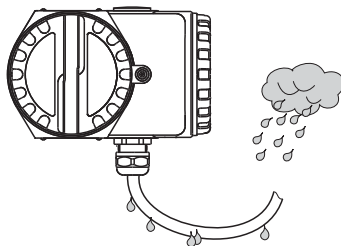
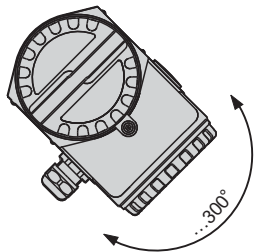

KO-설정

하우징을 여십시오.

①.

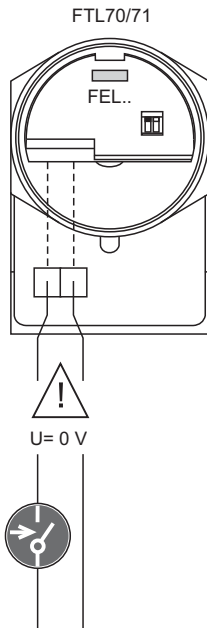

②.

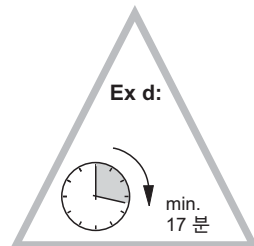

③.

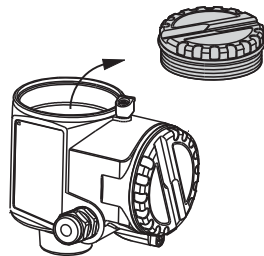

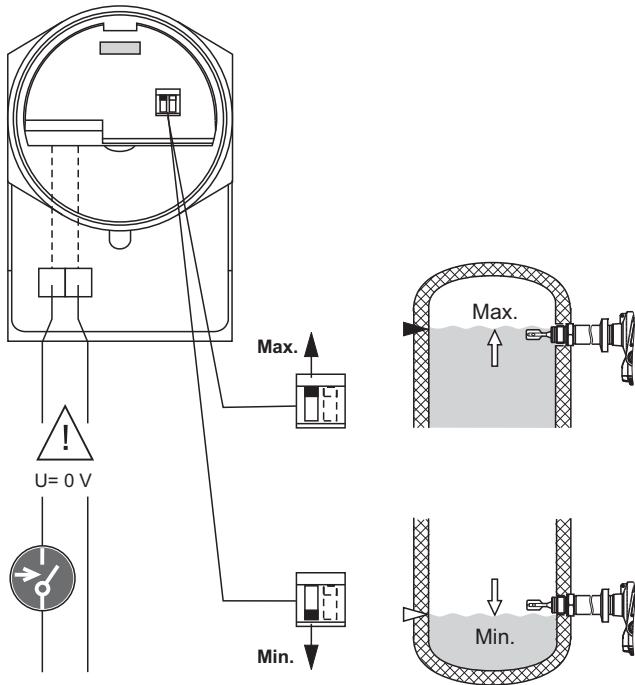

KO-유체 밀도에 따른 설정
 밀도는 g/cm^3 또는
 kg/l 로 측정됨

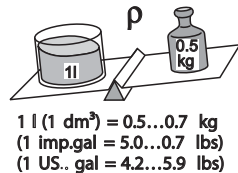
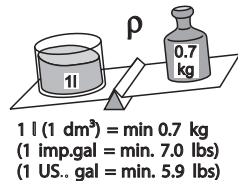
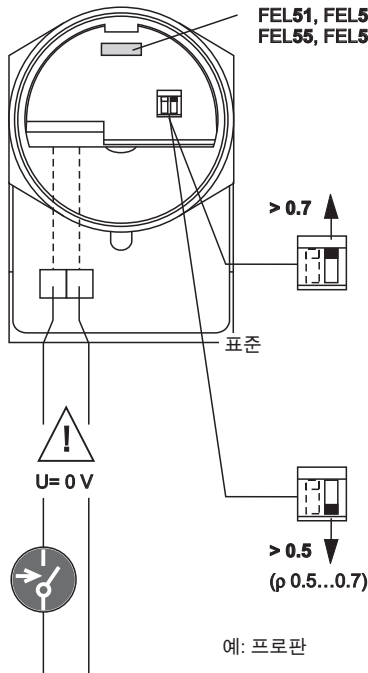

예: 프로판

KO-자가 테스트 FEL57
 (48, 49 페이지 및 시퀀스를
 위한 스위칭 유닛 참조)

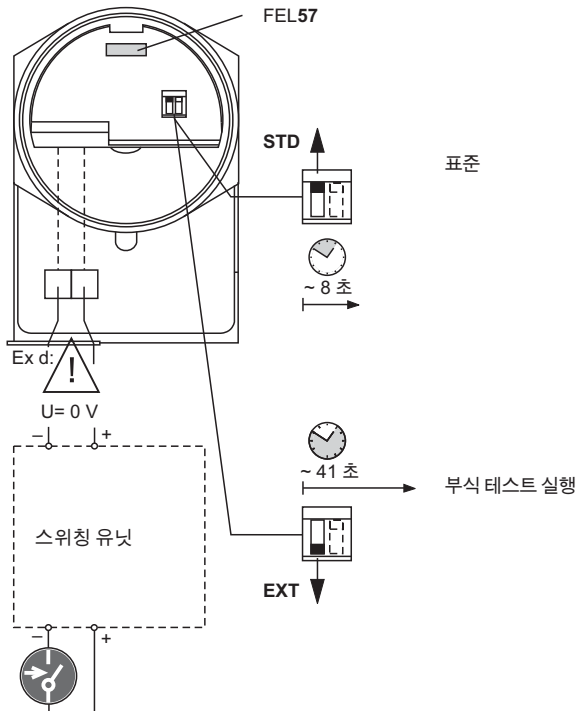

KO-기기 주소 설정
 (파라미터 설정,
 BA141F 참조)

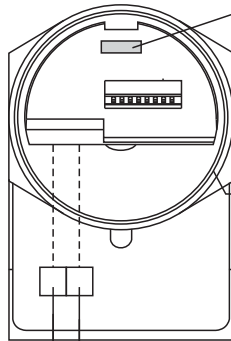

ON	1	2	4	8	16	32	64	SW
OFF	0	0	0	0	0	0	0	HW
	1	2	3	4	5	6	7	8

예

$2 + 8 = 10 =$ 주소

세그먼트 커플러

예: PLC

KO-점등 신호

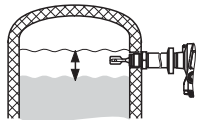

레벨 변화

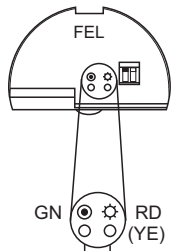

LED

● 대기

☀ 스위칭 상태

☀ FEL57, FEL50A: 커버링

☀ 켜짐

☀ 점멸

● 꺼짐

⊖ → 출력 신호

⌋ 고장

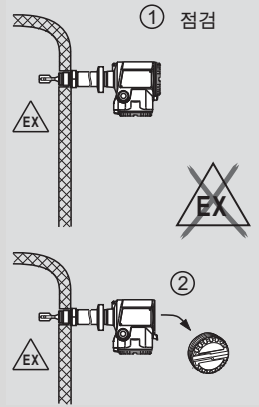

① 점검



②



국가 규정 참조!

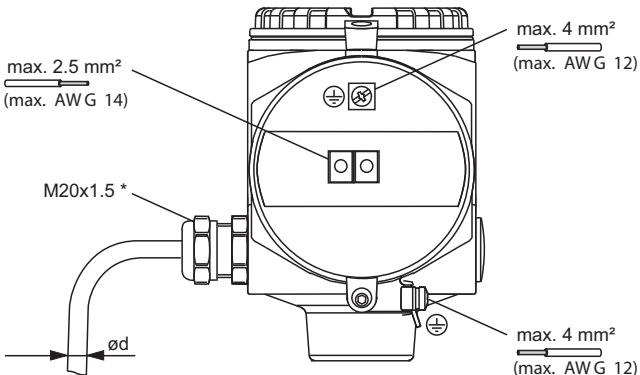
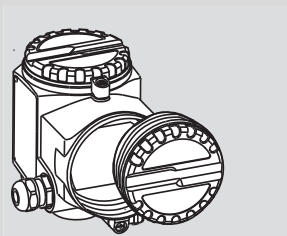

명판 참조 ☒ FEL..

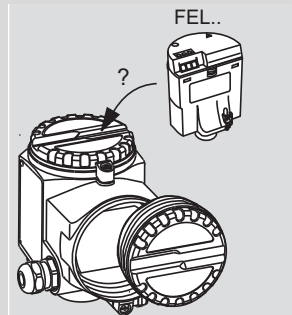
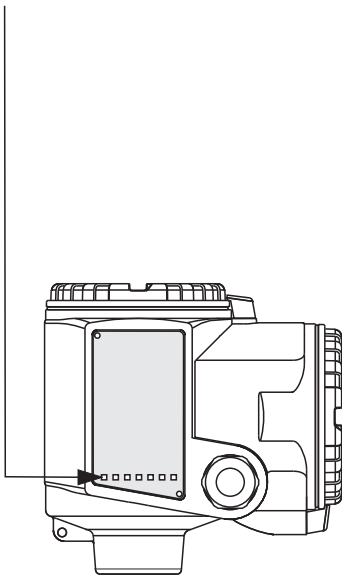

KO- FEL51 연결
2 선 AC 연결

 파손

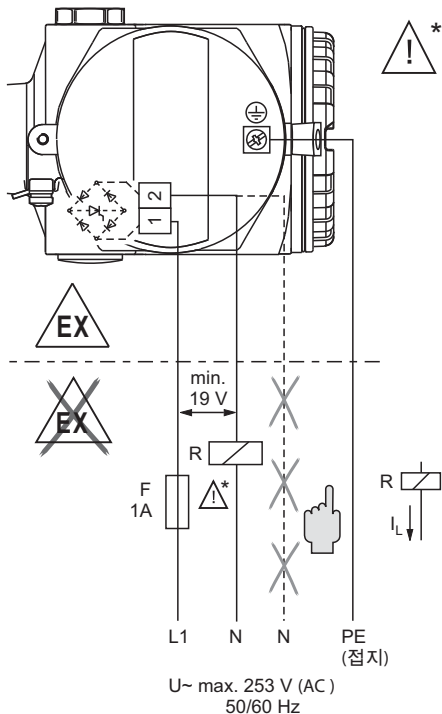

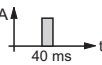
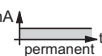
$I_{L,max.}$ 1.5 A 
$I_{L,max.}$ 350 mA  max. 89 VA / 253 V max. 8.4 VA / 24 V
min. 2.5 VA / 253 V (10 mA) min. 0.5 VA / 24 V (20 mA)

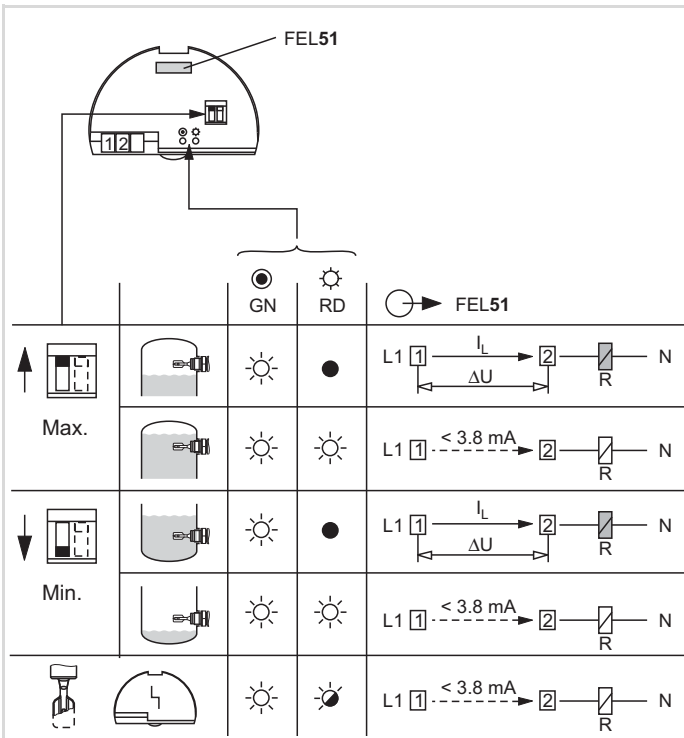

ΔU_{FEL51} 최대 12 V

KO- FEL52 연결
DC 연결 (PNP)

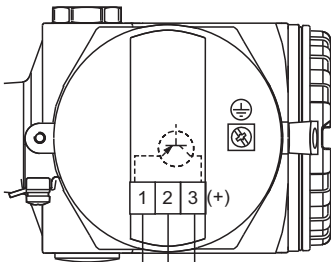

DI 모듈도 해당

EN 61131-2

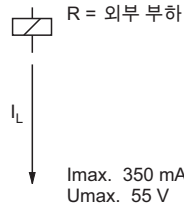
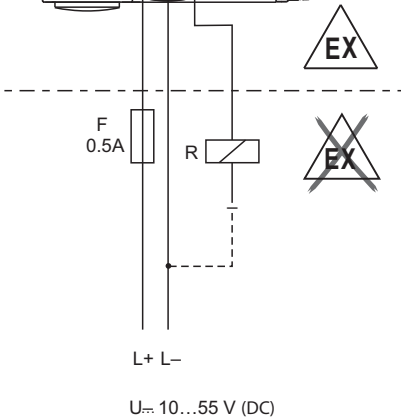

KO- FEL52 기능

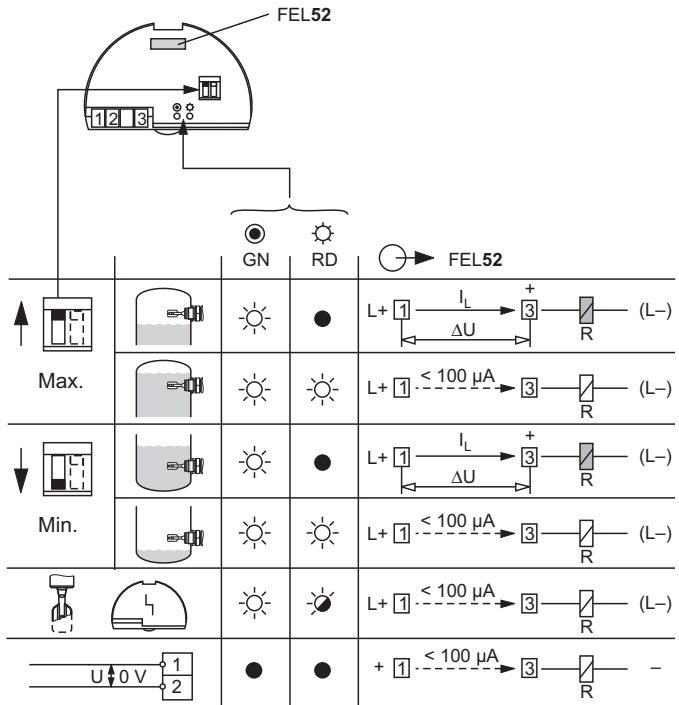

ΔU_{FEL52} 최대 3 V

KO- FEL54 연결
범용 릴레이 출력 연결

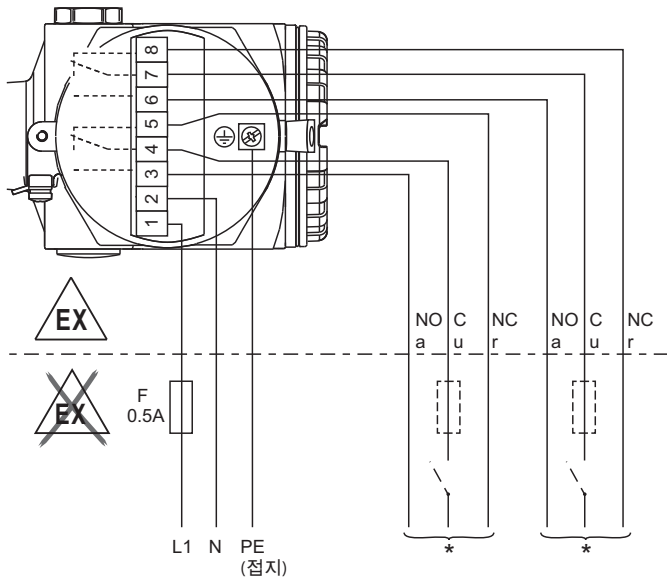

U_{\sim} 19...253 V (AC)

L+ L-

U_{\dots} 19... 55 V (DC)

$\left\{ \begin{array}{l} U_{\sim} \text{ max. } 253 \text{ V, } I_{\sim} \text{ max. } 6 \text{ A} \\ P_{\sim} \text{ max. } 1500 \text{ VA, } \cos \varphi = 1 \\ * P_{\dots} \text{ max. } 750 \text{ VA, } \cos \varphi > 0.7 \\ I_{\dots} \text{ max. } 6 \text{ A, } U_{\dots} < 30 \text{ V} \\ I_{\dots} \text{ max. } 0.2 \text{ A, } U_{\dots} < 125 \text{ V} \end{array} \right.$

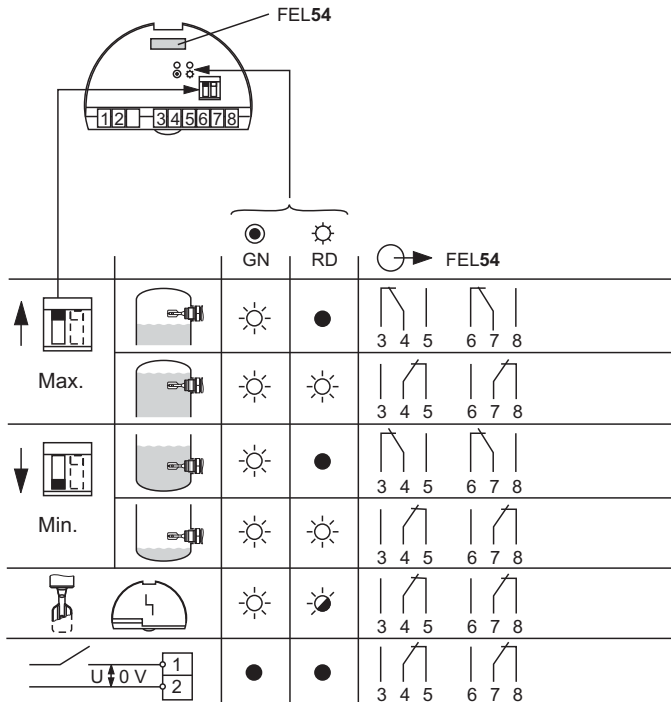

KO- FEL55 연결
8/16 mA 출력
*** 습한 연결**

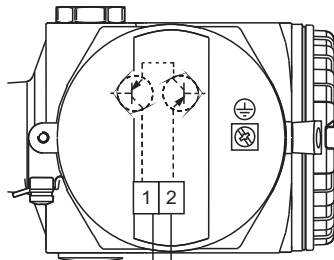

- + Ex ia



F T 50 mA

비방폭 애플리케이션 용으로는
 퓨즈가 필요합니다.
 안전 갈바닉 아이솔레이터가
 있는 전원만 사용하십시오.
 전원 공급 장치만 사용하십시오.



$$R_{\max} = \frac{U - 11 \text{ V}}{16.8 \text{ mA}}$$

PLC,
 AI 모듈,
 ...

U = 11...36 V (DC)
 U = 11...35 V (DC) *

4...20 mA
 EN 61 131-2

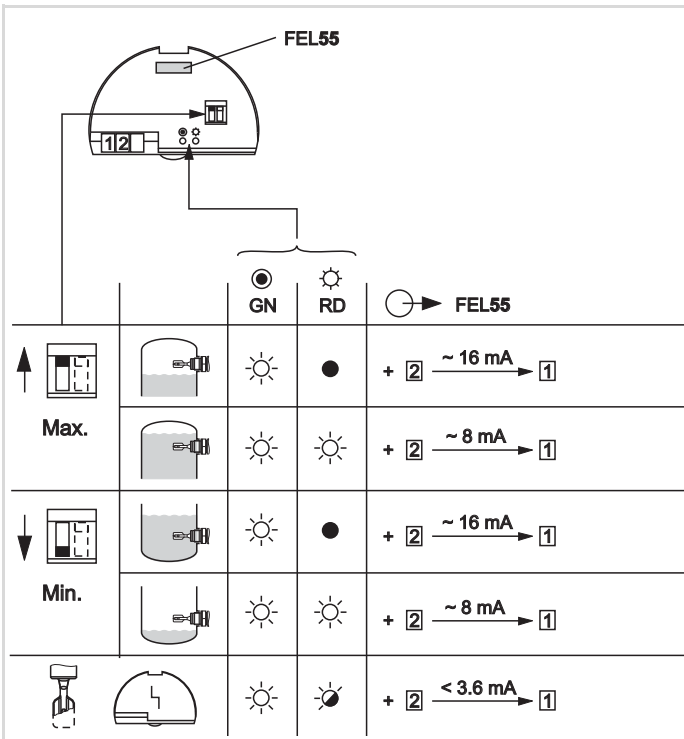

KO- FEL56 연결
NAMUR 출력 L-H
< 1.0 mA / > 2.2 mA

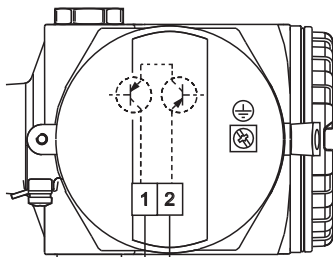

EEx ia



H 2.2...2.8 mA
 L 0.6...1.0 mA



- +

절연 증폭기 - NAMUR
 (IEC 60947-5-6)

예:
FXN421, FXN422, SIN100, SIN110,
FTL325N, FTL375N

멀티플렉서: 듀티 펄스 사이클 최소 2초

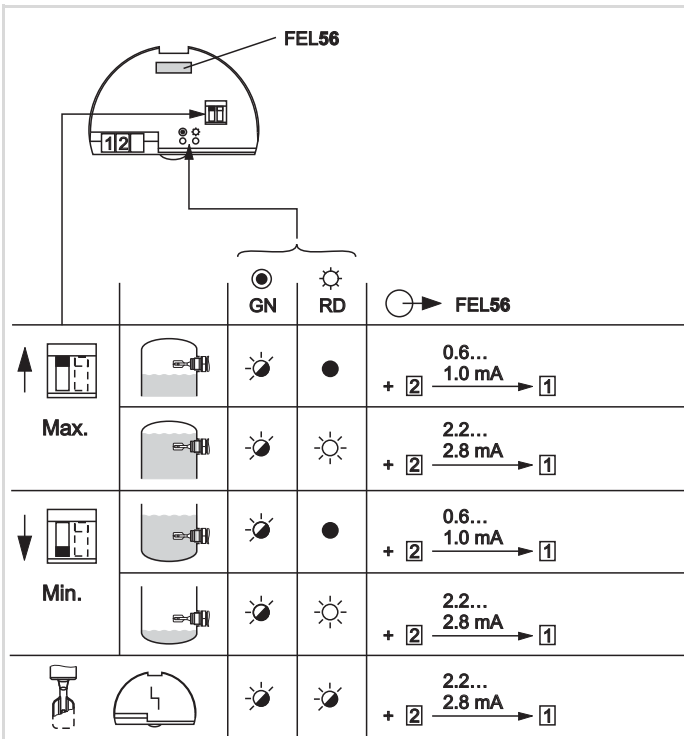

KO-FEL 57 연결
PFM 출력
150 Hz / 50 Hz

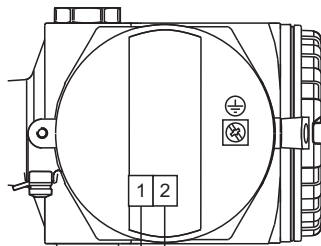

기능 참조!



EEx ia

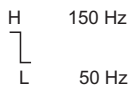

150 Hz

50 Hz

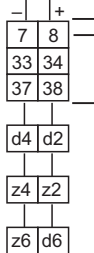

Nivotester FTL325P (CH1), FTL320, FTL120Z

Nivotester FTL325P (CH3)

Nivotester FTL375P (CH1), FTL370/372, FTL170Z



Nivotester FTL375P (CH2), FTL372, FTL170Z



Nivotester FTL375P (CH3)



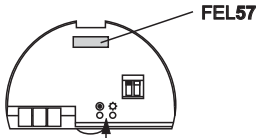

	GN	YE	FEL57

* 스위치 온 동작



KO- FEL57 기능
STD 모드에서 스위치온 동작

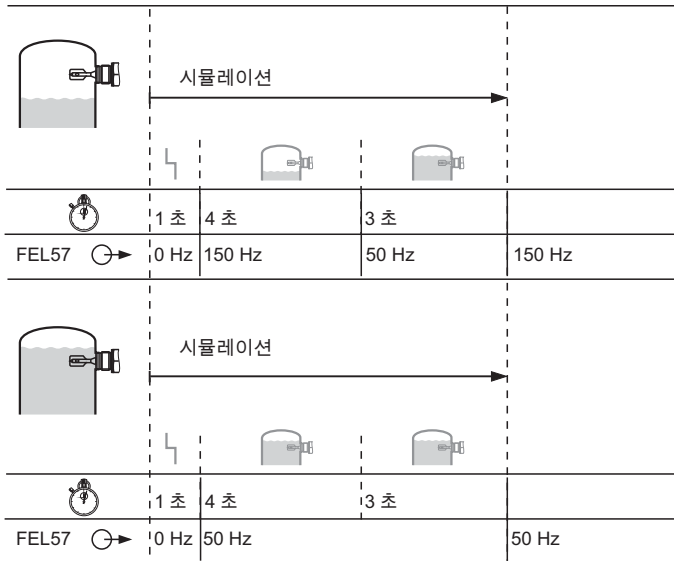
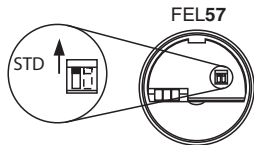

KO- FEL57 기능
EXT 모드에서 스위치온 동작

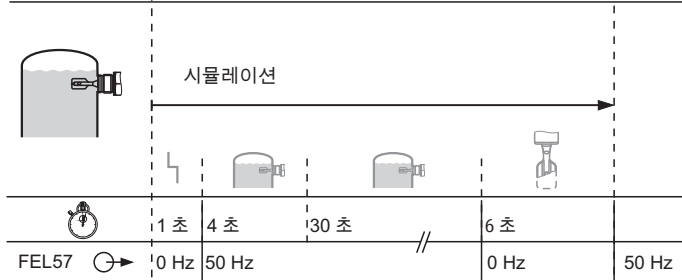
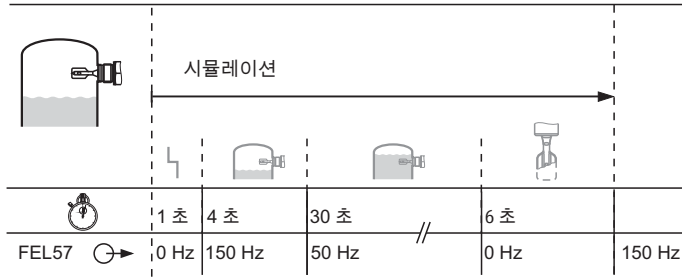
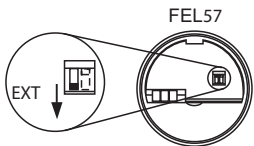

KO- FEL50A 연결

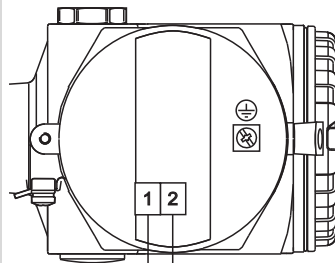

PA- PA+

U... 9...32 V (DC)

세그먼트 커플러

예: PLC

		GN	YE	PA 버스 신호
반전 안 됨				OUT_D = 0
				OUT_D = 1
반전됨				OUT_D = 0
				OUT_D = 1
			-	통신
		-		상태, BA141F 참조
				../..

KO- FEL58 연결
NAMUR 출력 H-L
> 2.2 mA / < 1.0 mA

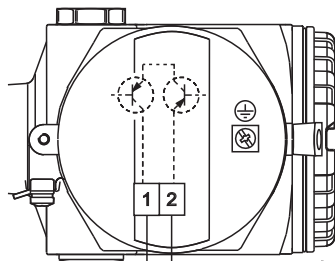

EEx ia



H 2.2...3.5 mA
 L 0.6...1.0 mA

절연 증폭기 - NAMUR
 (IEC 60947-5-6)





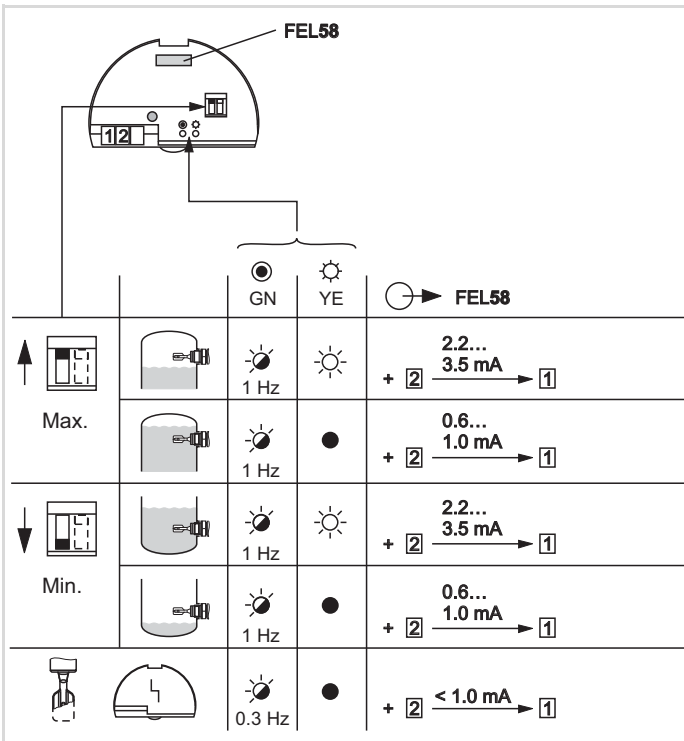



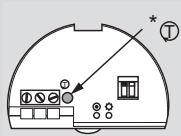







예:
FXN421, FXN422, SIN100, SIN110,
FTL325N, FTL375N

멀티플렉서: 듀티 펄스 사이클 최소 2초













KO-MAX 모드에서의
FEL58 테스트 버튼 기능

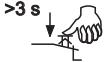

		
<p>1. 정상 작동</p>	<p>GN YE   1 Hz + 2.2... 3.5 mA → 1 2</p>	<p>GN YE   1 Hz + 0.6... 1.0 mA → 1 2</p>
<p>2. 테스트 버튼 누름</p> 	<p>GN YE   + 0 mA → 1 2</p>	<p>GN YE   + 0 mA → 1 2</p>
<p>3. ~2초 정상 작동 후 테스트 버튼 해제</p> 	<p>GN YE   1 Hz + 2.2... 3.5 mA → 1 2</p>	<p>GN YE   1 Hz + 0.6... 1.0 mA → 1 2</p>

KO-MIN 모드에서의
FEL58 테스트 버튼 기능

		
<p>1. 정상 작동</p>	<p>GN YE  1 Hz + 2.2... 2 3.5 mA → 1</p>	<p>GN YE  1 Hz + 0.6... 2 1.0 mA → 1</p>
<p>2. 테스트 버튼 누름</p> 	<p>GN YE  + 0 mA 2 -----> 1</p>	<p>GN YE  + 0 mA 2 -----> 1</p>
<p>3. ~2초 정상 작동 후 테스트 버튼 해제</p> 	<p>GN YE  1 Hz + 2.2... 2 3.5 mA → 1</p>	<p>GN YE  1 Hz + 0.6... 2 1.0 mA → 1</p>

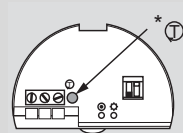

KO-유지보수, 세척
센서에 붙은 유체를
제거하십시오.

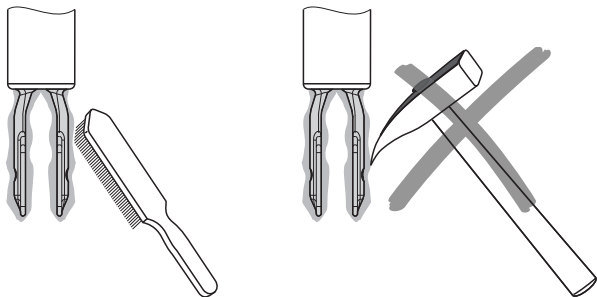

발판으로 사용하지 말 것!

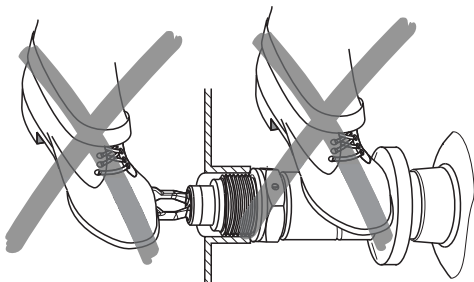

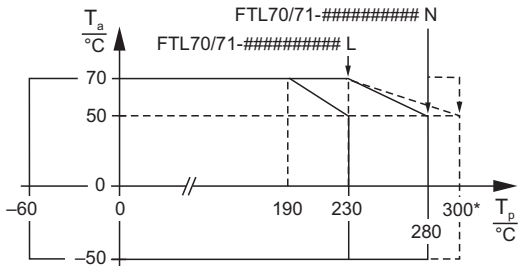
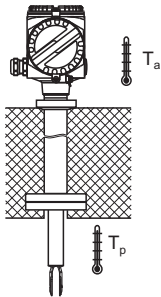
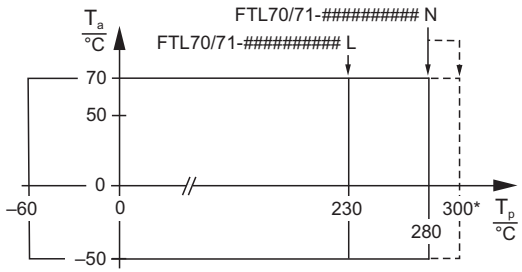
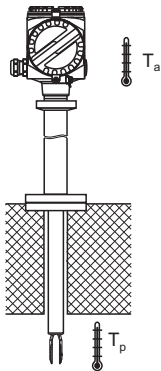

KO-기술 데이터
주변 온도 T_a
처리 온도 T_p

프로세스 압력



프로세스 연결부 / 액세서리

$p_e = \text{max. } 100 \text{ bar (1450 psi)*}$

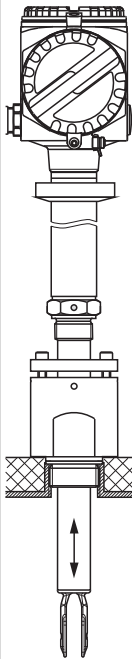

G 1
1.4435 (AISI 316L)
52003663

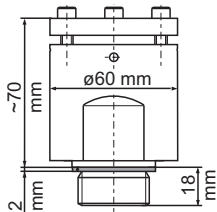

NPT 1
1.4435 (AISI 316L)
52003667

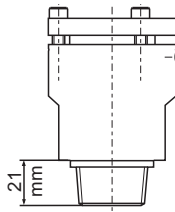

G 1½
1.4435 (AISI 316L)
52003665

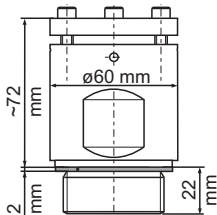

NPT 1½
1.4435 (AISI 316L)
52003669

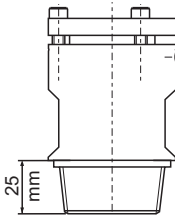

KO-엑세서리
고압 슬라이딩 슬리브

참조 :

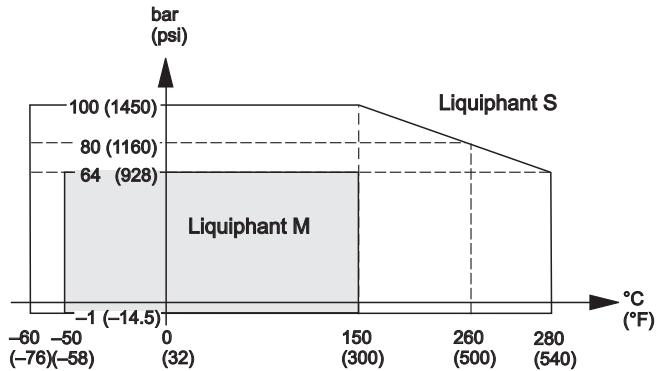

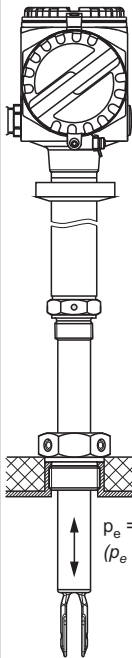

G 1
52003978

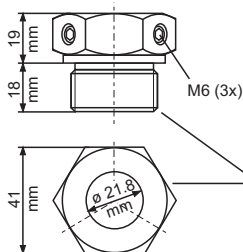

NPT 1
52003979

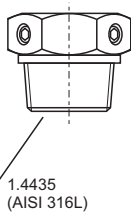

G 1½
52003980

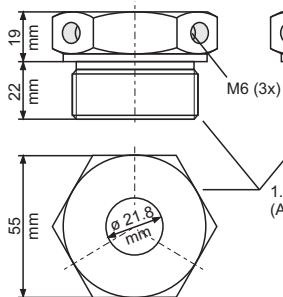

NPT 1½
52003981

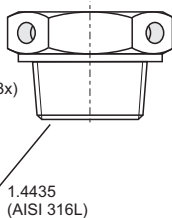

KO-슬라이딩 슬리브
비가압 작동용

참조 :

KO-문제 해결

고장	이유	조치
스위칭 안 됨	전원 없음	전원 점검
	고장 난 신호선	신호선 점검
	고장 난 기관 - FEL51 이 L1 및 N 에 직접 연결	교체 - 항상 FEL51 을 외부 부하를 통해 연결
	유체 밀도가 너무 낮음	기관에서 밀도를 > 0.5 로 설정
	포크에 유체층 축적	포크 세척
	포크 부식 (FEL 에 표시 : 적색 / 황색 점멸, FEL58: 녹색 점멸 0.3 Hz)	포크 및 프로세스 연결부 교체
	FEL51: 연결된 릴레이의 내부 저항이 너무 큼	적합한 릴레이 연결
	FEL51: 연결된 릴레이의 유지 전류가 너무 낮음	저항기를 릴레이와 병렬로 연결
잘못된 스위칭	FEL54: 접점 음착 (단락 이후)	FEL54 교체 . 접점 회로에 퓨즈 설치
	잘못 설정된 최소 / 최대 고장 안전 모드	기관에서 올바른 모드 설정
산발적인 스위칭 고장	두꺼운 기포, 매우 거친 조건, 발포성 유체	Liquiphant 를 우회해서 설치
	극심한 RFI	차폐 케이블 사용
	극심한 진동	디커플링, 댐핑, 포크를 90° 회전
	하우징 내부의 물	커버와 케이블 그랜드를 꼭 조임
전원 장애 후 잘못된 스위칭	FEL52: 출력 과부하	부하, (케이블) 커패시턴스 감소
	FEL57, 스위치 온 테스트 (기능 테스트) 중 동작	FEL57 의 스위칭 동작 관찰 . 전원 장애 후 최대 45 초 동안 공장 제어 차단

KO-문제 해결 추가 정보

포크의 스위칭 동작이
비정상적이면, 진단 소켓의
PIN 4 에서 포크 주파수를
측정할 수 있습니다.

기관 FEL51/52/54/55/56/57/
58 의 경우 정현 진동의
진폭으로 포크의 상태를 파악할
수 있습니다.

FEL50A 의 경우 직사각형
펄스 신호 때문에 포크 주파수
측정만 가능합니다.

KO-예비 부품
기판



FEL51	52002304
FEL52	52002305
FEL54	52002306
FEL55	52002307
FEL56	52002308
FEL57	52002309
FEL58	52006454
FEL50A	52010527

설치 사양: 설치 중 한 번이라도 본질 안전 전원이 아닌 전원에 연결된 기판은 더 이상 **본질 안전 회로에 연결할 수 없습니다.**

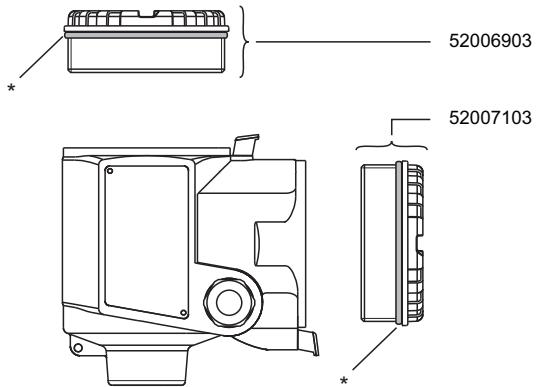

* 실리콘 그리스로 윤활

①.

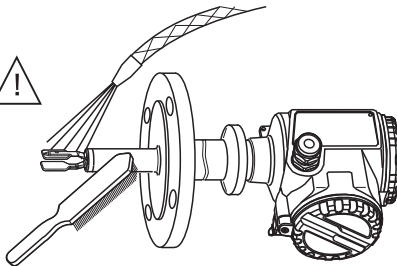

세척

②.

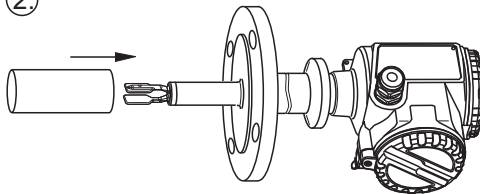

운반 보호

③.

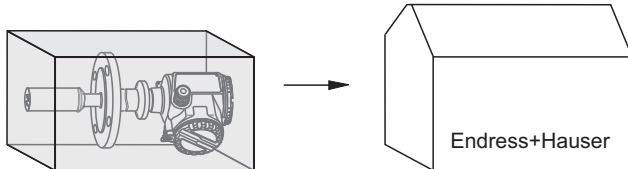

기술 정보

TI00354F Liquiphant FTL70, FTL71

TI00426F 어댑터, 레벨 및 압력

사용 설명서

BA00141F FEL50A, PROFIBUS PA

안전 지침

XA00031F 4 0 II 1/2 G, EEx d IIC/IIB

XA00063F 4 0 II 1/2 G, II 1/2 D, EEx ia/ib IIC/IIB

XA00064F 4 0 II 1 G, EEx ia IIC/IIB

XA00108F 4 0 II 1/2 G, EEx de IIC/IIB

XA00113F 4 0 II 1/2 G, EEx ia/ib IIC

XA00114F 4 0 II 1/2 G, EEx d IIC

XA00115F 4 0 II 1/2 G, EEx de IIC

XA00154F 4 0 II 1/2 G, II 1/2 D, EEx ia/ib IIC/IIB

XA00158F 4 0 II 1/2 G, EEx ia/ib IIC

XA00159F 4 0 II 1 G, EEx ia IIC/IIB

XA00182F 4 0 II 3 G, II 3 D, EEx nA/nC IIC/IIIC

KO-참고 자료



71310295

www.endress.com/worldwide
