

Çalıştırma Talimatları **Liquiphant M FTL50, FTL51**

Limit Seviye Sivici

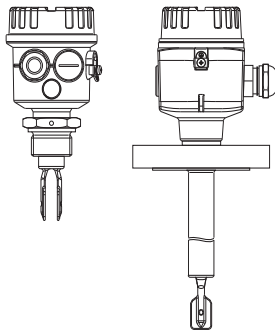

TR - İçindekiler

Güvenlik Notları	3
Taşınması	4
Cihaz Kimliği	6
Uygulama	12
Ölçüm sistemi	13
Montaj	17
Kurulum	26
Işık sinyalleri	30
Bağlantılar	31
Bakım, Temizlik	52
Teknik Veriler	53
Aksesuarlar	55
Sorun giderme	58
Yedek parçalar	60
Onarım	61
Ek Dokümantasyon	62



Uyarı!

= yasaktır;

hatalı çalışmaya veya kullanılamaz hale gelmesine yol açar.

TR- Güvenlik Notları

Liquiphant M FTL50, FTL51 sınırlardaki limit seviye tespiti için tasarlanmıştır.

Yanlış kullanılması durumunda uygulama kaynaklı tehlikeler ortaya çıkabilir.

Seviye limit siviçi Liquiphant M FTL50, FTL51 sadece **eğitim**

almış, yetkili personel

tarafından, bu çalıştırma talimatlarına, ilgili tüm standartlara, kanuni gereksinimlere ve geçerli durumlarda sertifikaya uygun şekilde kurulabilir, bağlanabilir, devreye alınabilir, çalıştırılabilir ve bakımı yapılabilir.

Cihazın yanına kolay ulaşılabilen bir güç siviçi takın.

Bu güç siviçini cihazın devre kesicisi olarak işaretleyin.

TR- Taşınması

Muhafaza, flanş veya uzatma borusundan tutun.

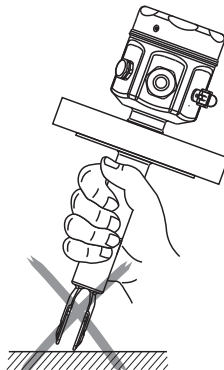
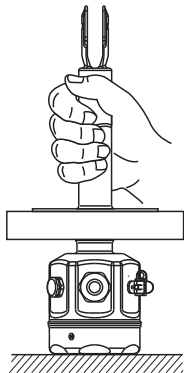
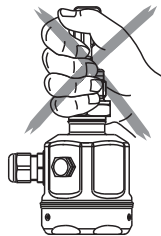
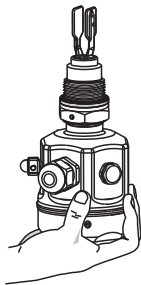

TR- Bükme**ym**
Kısalt**ma**ym
Uzat**ma**ym

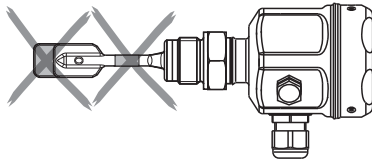
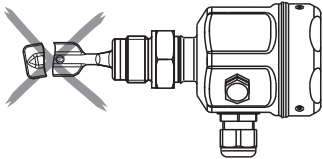
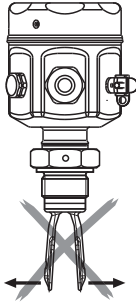
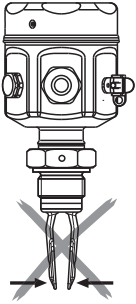



ENDRESS+HAUSER
LIQUIPHANT M

Sipariş kodu

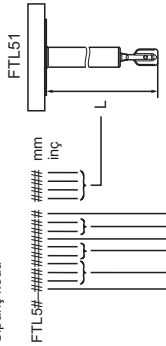

A *¹
B
C
D
E
F
G
H
I
J
K
L
M
N
P
Q
R
S
T
U
V
W
X
7
8
Y

ATEX II 3 G EEx nC II T6, WHG
ATEX II 3 D T85°C*³
ATEX II 3 G EEx nA II T6, WHG
ATEX II 3 D T85°C*³
*¹, WHG
ATEX II 1/2 G EEx de IIC T6, WHG
ATEX II 1/2 G EEx ia IIC T6, WHG
ATEX II 1/2 D T80°C*³
ATEX II 1/2 G EEx ia IIC T6
ATEX II 1/2 D T80°C*³
ATEX II 1 G EEx ia IIC T6
ATEX II 1/2 G EEx de IIC T6
ATEX II 1 G EEx ia IIC T6, WHG
ATEX II 1/2 G EEx d IIC T6
ATEX II 1/2 G EEx d IIC T6, WHG
NEPSI Ex ia IIC T6
NEPSI Ex d IIC T6

Bölüm. 1, Gr. A-G
Bölüm. 1, Gr. B-G, E5 => Gr. A-G
Bölüm. 2, Gr. A-D
Bölüm. 1, Gr. A-G
Bölüm. 1, Gr. A-G

CSA Genel amaçlı
TIIS Ex ia IIC T3
TIIS Ex d IIB T3
TIIS Ex ia IIC T6
TIIS Ex d IIC T3
TIIS Ex d IIC T6

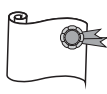

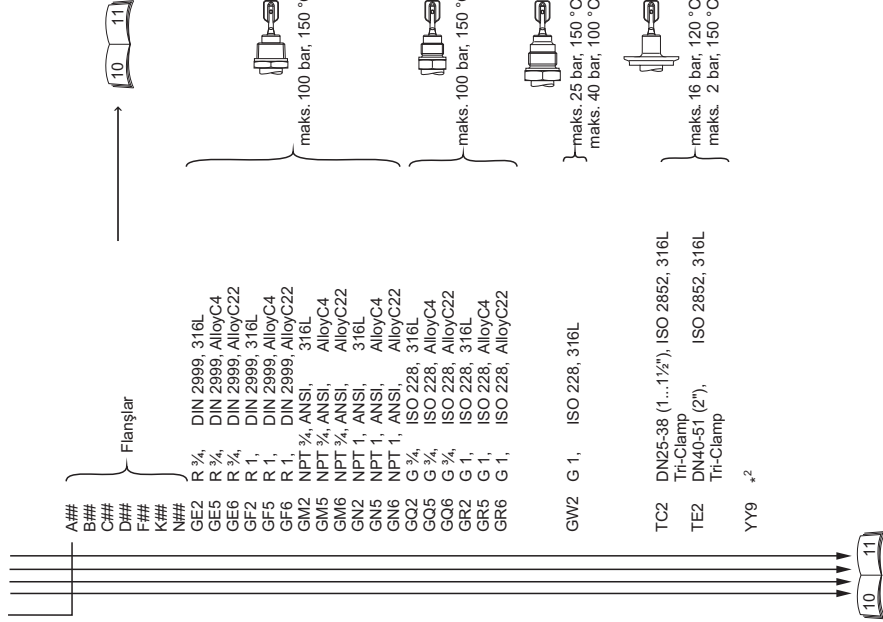

*1

hariç

*2

diğerleri

*3

PBT için geçerli değil



ENDRESS+HAUSER
LIQUIPHANT M

Sipariş kodu

FTL5#-#####
mm
inç

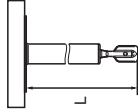

FTL51

AA	* ²		Ra < 3,2 µm/80 tanecek (FTL50)
BB	 mm, 316L,	Ra < 3,2 µm/80 tanecek
BE	 mm, AlloyC4,	Ra < 3,2 µm/80 tanecek
CB	 inç, 316L,	Ra < 3,2 µm/80 tanecek
CE	 inç AlloyC4,	Ra < 3,2 µm/80 tanecek
DB	 mm, 316L,	Ra < 3,2 µm/80 tanecek
DE	 mm, AlloyC4,	Ra < 3,2 µm/80 tanecek
IA	* ²		+ "T" (FTL50)
JB	 mm, 316L	+ "T"
JE	 mm, AlloyC4	+ "T"
KB	 inç, 316L	+ "T"
KE	 inç AlloyC4	+ "T"
LB	 mm, 316L	+ "T"
LE	 mm, AlloyC4	+ "T"
QA	* ²		+ "p" (FTL50)
RB	 mm, 316L	+ "p"
RE	 mm, AlloyC4	+ "p"
SB	 inç, 316L	+ "p"
SE	 inç AlloyC4	+ "p"
TB	 mm, 316L	+ "p"
TE	 mm, AlloyC4	+ "p"
YY	* ²		

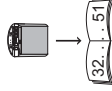
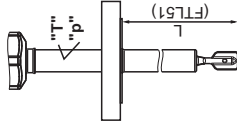

A	FEL50A, PROFIBUS PA
1	FEL51, 19...253 V AC
2	FEL52, 10... 55 V DC, PNP
4	FEL54, 19...253 V AC, 19...55 V DC, DPDT
5	FEL55, 11... 36 V DC, 8/16 mA
6	FEL56, NAMUR, L-H
7	FEL57, PFM
8	FEL58, NAMUR, H-L
9	* ²

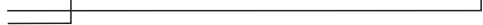

- E1 F27 NEMA6P, NPT ¾
- E4 F16, NEMA4X, NPT ½
- E5 F13/17, NEMA4X, NPT ¾
- E6 F15, NEMA4X, NPT ½
- F1 F27, IP68, G ½
- F4 F16, IP66, G ½
- F5 F13/17, IP66, G ½
- F6 F15, IP66, G ½
- G1 F27, IP68, M20
- G4 F16, IP66, M20
- G5 F13/17, IP66, M20
- G6 F15, IP66, M20
- N4 F16, IP66, M12
- N5 F13/17, IP66, M12
- N6 F15, IP66, M12
- Y9 *²



F16 (PBT)



F13/17 (Alu)
F27 (316L)



F15 (316L)



#3 Kompakt muhafaza



#7 Alu/sep.

- A *¹
- B PVIS bulunmaz
- C EN 10204 - 3.1, 316L
- K Özel ayar yoğunluk H20
- L Özel ayar yoğunluk H20, EN10204-3.1
- N EN 10204 - 3.1, NACE MR0175, 316L
- P 100 bar (FTL51)
- R 100 bar, EN 10204 - 3.1, NACE MR0175, 316L (FTL51)
- S GL/ABS denizcilik sertifikası (FTL51: max. 1600 mm)
- Y *²

*¹ hariç

*² diğerleri

"L II" Anahtarlama noktası

Liquiphant II FTL 360/365, FDL 30/35

"T" Sıcaklık mesafe parçası

"p" Basınç sızdırmayan burç

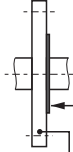

ANSI B 16.5

AA2	1¼", 150 lbs, RF, 316/316L
AB2	1½", 300 lbs, RF, 316/316L (FTL51)
AC2	1½", 150 lbs, RF, 316/316L
AD2	1½", 300 lbs, RF, 316/316L (FTL51)
AE2	2", 150 lbs, RF, 316/316L
AE5	2", 150 lbs, RF, Alloy C4 >316/316L
AE6	2", 300 lbs, RF, Alloy C22 >316/316L
AF2	2", 300 lbs, RF, 316/316L
AG2	2", 600 lbs, RF, 316/316L (FTL51)
AJ2	2½", 300 lbs, RF, 316/316L (FTL51)
AL2	3", 150 lbs, RF, 316/316L
AM2	3", 300 lbs, RF, 316/316L (FTL51)
AN2	3", 600 lbs, RF, 316/316L (FTL51)
AP2	4", 150 lbs, RF, 316/316L
AQ2	4", 300 lbs, RF, 316/316L (FTL51)
AR2	4", 600 lbs, RF, 316/316L (FTL51)
A82	1", 150 lbs, RF, 316/316L

EN 1092-1

BA2	DN32, PN6 A, 316L
BB2	DN32, PN25/40 A, 316L
BC2	DN40, PN6 A, 316L
BD2	DN40, PN25/40 A, 316L
BE2	DN50, PN6 A, 316L
BG2	DN50, PN25/40 A, 316L
BH2	DN65, PN6 A, 316L
BJ2	DN50, PN100 A, 316L (FTL51)
BK2	DN65, PN25/40 A, 316L
BM2	DN80, PN10/16 A, 316L
BN2	DN80, PN25/40 A, 316L
BQ2	DN100, PN10/16 A, 316L
BR2	DN100, PN25/40 A, 316L

B12	DN80,	PN100 A,	316L (FTL51)
B82	DN25,	PN25/40 A,	316L
CA2	DN32,	PN6 B1,	316L
CA5	DN32,	PN6,	AlloyC4 >316L
CA6	DN32,	PN6,	AlloyC22 >316L
CE2	DN50,	PN6 B1,	316L
CE5	DN50,	PN6,	AlloyC4 >316L
CE6	DN50,	PN6,	AlloyC22 >316L
CG2	DN50,	PN25/40 B1,	316L
CG5	DN50,	PN25/40,	AlloyC4 >316L
CG6	DN50,	PN25/40,	AlloyC22 >316L
CJ2	DN50,	PN100 B2,	316L (FTL51)
CN2	DN80,	PN25/40 B1,	316L
CN5	DN80,	PN25/40,	AlloyC4 >316L
CN6	DN80,	PN25/40,	AlloyC22 >316L
CQ2	DN100,	PN10/16 B1,	316L
CQ5	DN100,	PN10/16,	AlloyC4 >316L
CQ6	DN100,	PN10/16,	AlloyC22 >316L
C12	DN80,	PN100 B2,	316L (FTL51)
C82	DN25,	PN25/40 B1,	316L
C85	DN25,	PN25/40,	AlloyC4 >316L
C86	DN25,	PN25/40,	AlloyC22 >316L
DG2	DN50,	PN40 B1,	316L
DN2	DN80,	PN40 B1,	316L
D82	DN25,	PN40 B1,	316L
FG2	DN50,	PN40 C,	316L
NG2	DN50,	PN40 D,	316L

JIS B2220

KA2	10K 25,	RF,	316L
KC2	10K 40,	RF,	316L
KE2	10K 50,	RF,	316L
KE5	10K 50,	RF,	AlloyC4 >316L
KE6	10K 50,	RF,	AlloyC22 >316L
KL2	10K 80,	RF,	316L
KP2	10K 100,	RF,	316L

TR- Uygulama

Akışkanlarda limit seviye tespiti

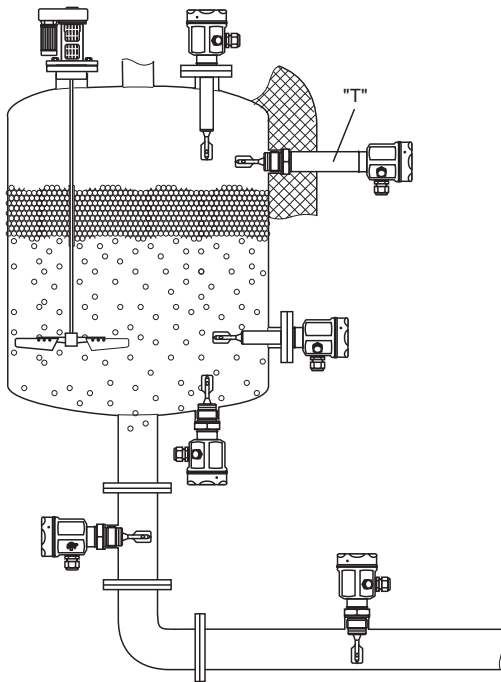

TR- Ölçüm sistemi

doğrudan bağlantı için

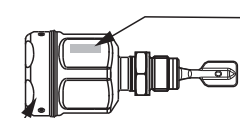

Elektronik uçlar

Sipariş kodu
FTL5# - # ### # # ## #

FEL51
FEL52
FEL54

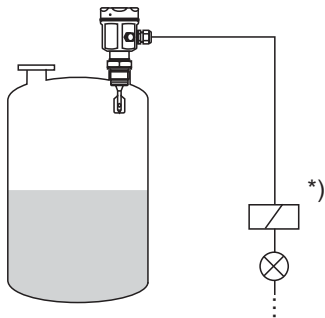

*)

*) Harici yük

TR- Ölçüm sistemi

anahtarlama ünitesi ile bağlantı için

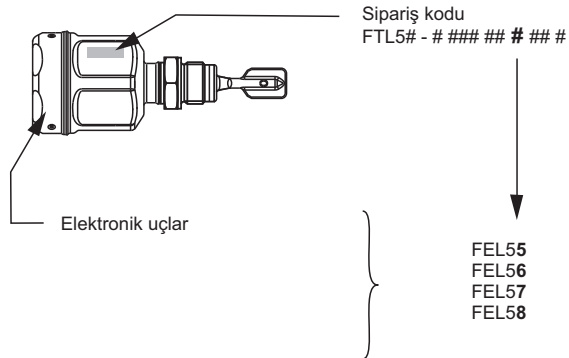

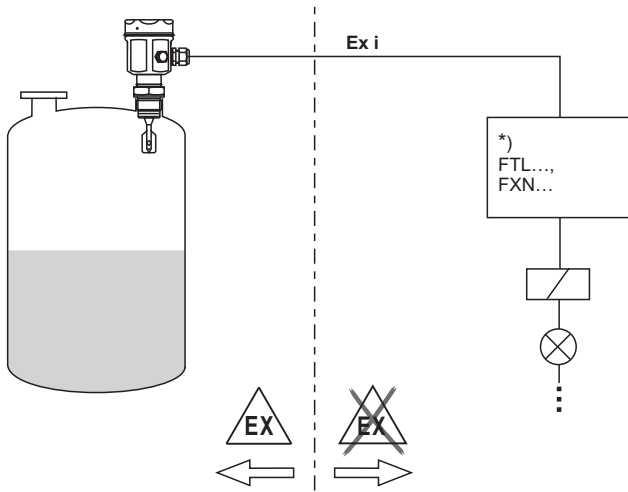

*) Anahtarlama ünitesi, PLC, izolasyon güçlendirici

TR- Ölçüm sistemi

PROFIBUS PA bağlantısı için

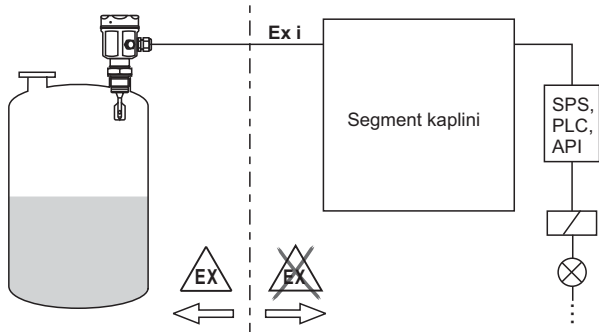
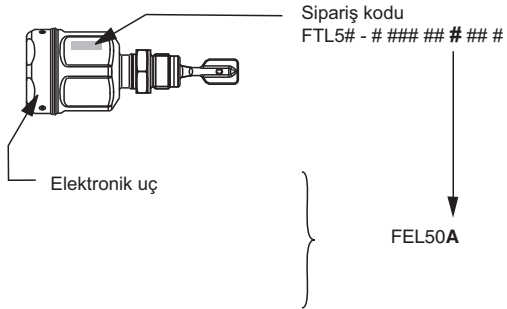

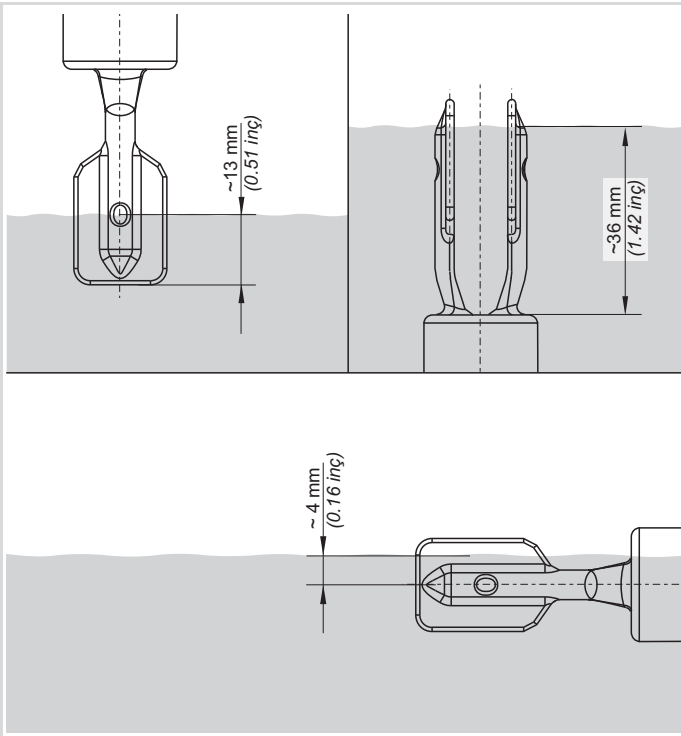

TR- Montaj

Anahtarlama noktası montaj pozisyonuna bağlıdır

TR- Montaj örnekleri
sıvı viskozitesi fonksiyonu olarak

$v = 0 \dots 2000 \text{ mm}^2/\text{s}$
($v = 0 \dots 2000 \text{ cSt}$)

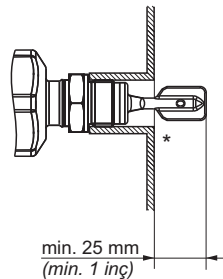
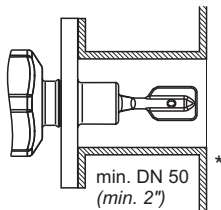

* çapak alma

$v = 0 \dots 10000 \text{ mm}^2/\text{s}$
($v = 0 \dots 10000 \text{ cSt}$)

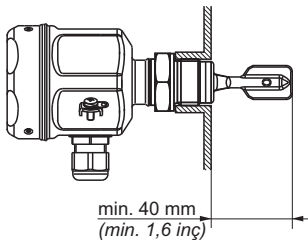

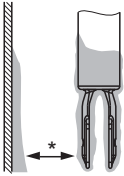

* Mesafe!

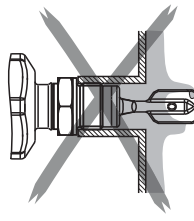
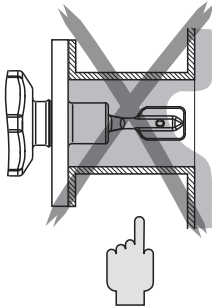
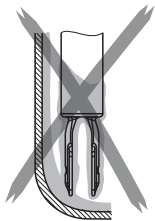
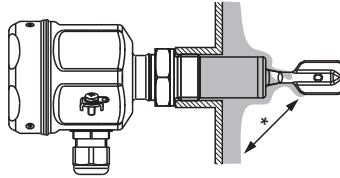

TR- Birikmeyi dikkate alın.
Çatal birikme ile temas etmemelidir.

TR- Dinamik kuvvet destek
durumunda

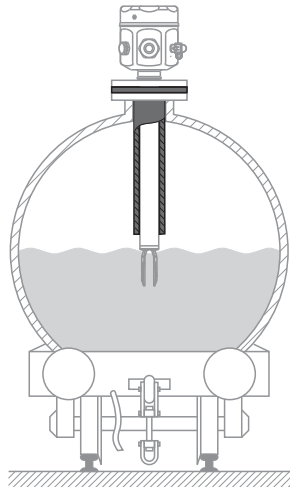
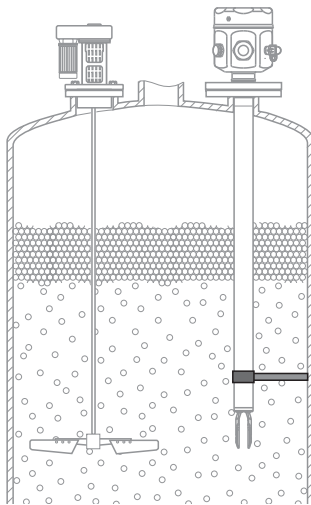

"T" = yalıtımlı tanklar için sıcaklık mesafe parçası ile

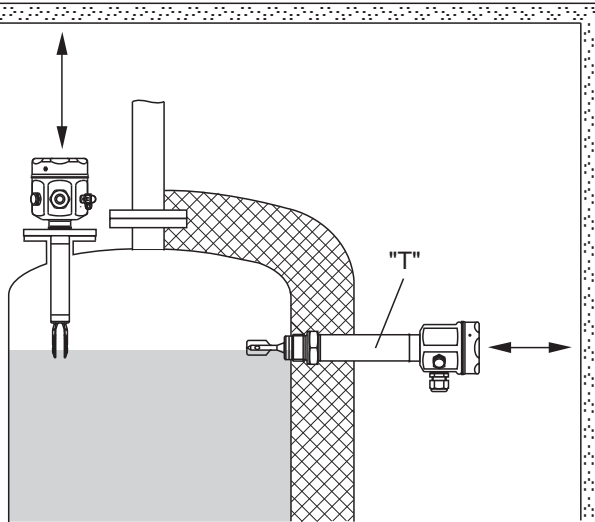

TR- Çatal dişlerinin yönü:
Yukarıyı veya aşağıyı gösteriyor

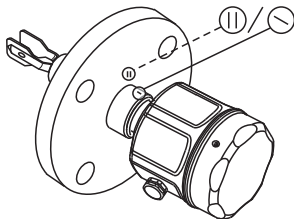
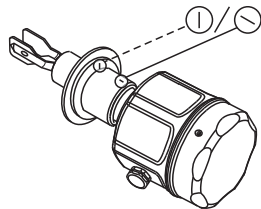
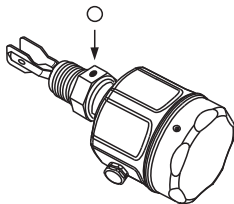
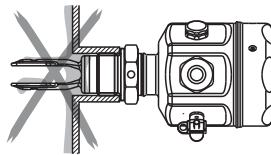
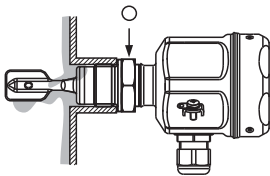

G ¾, 32 mm (1¼")*
G 1, 41 mm (1½")*

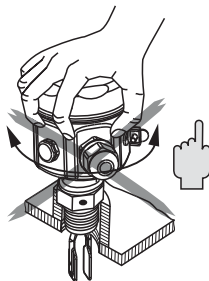
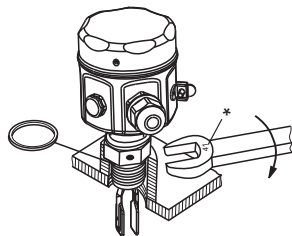

NPT ¾, R ¾, G ¾, 32 mm (1¼")*
NPT 1, R 1, G 1, 41 mm (1½")*

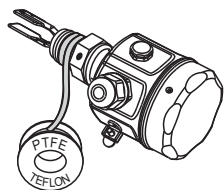

A

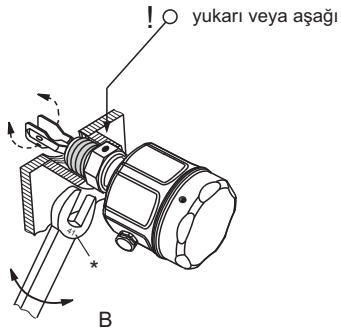

B

TR- Liquiphant'ı proses bağlantısına vidalayın.
Çevirmek için muhafazayı kullanmayın.

TR- Borularda yön:
Akış yönüne doğru işaretlenir

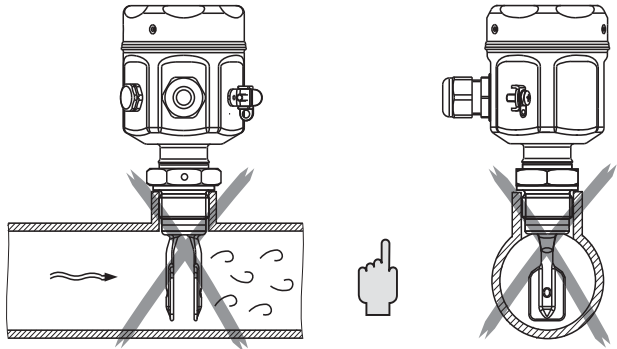
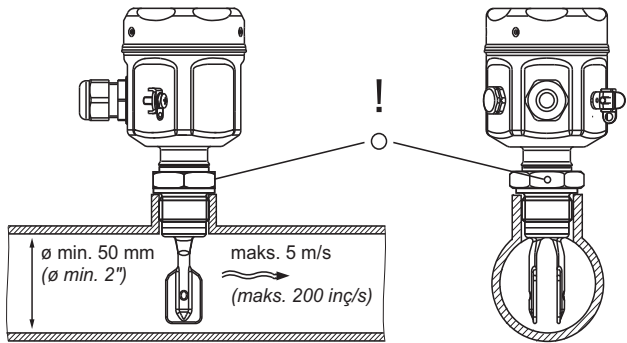

F15, F27

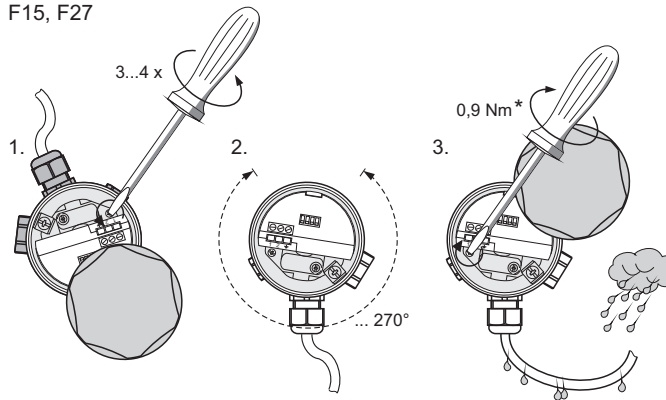

F16, F13, F17

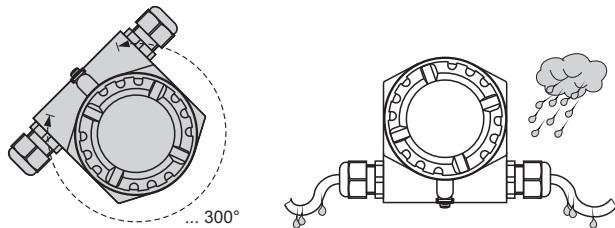

TR- Kablo rakoru yönü

* Tork

TR- Kurulum

Minimum/maksimum
güvenlik modu

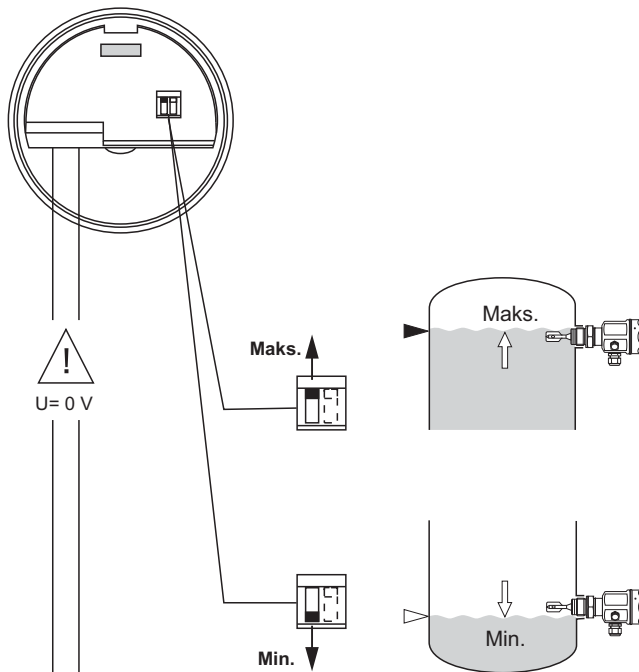

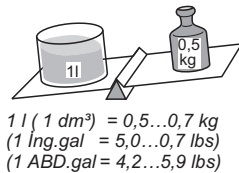
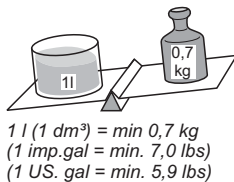
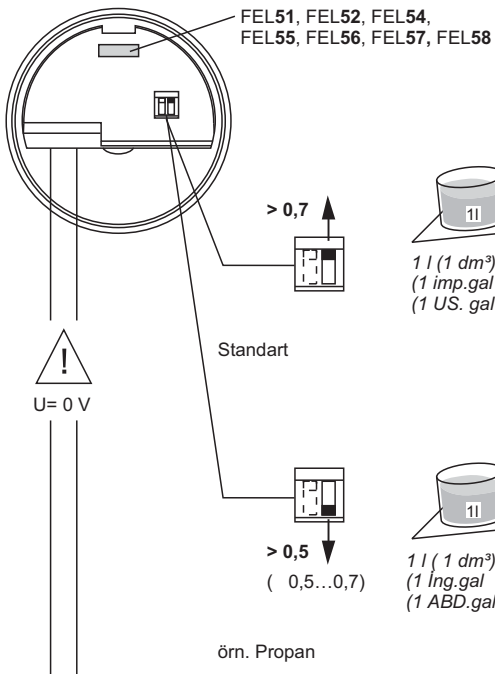

TR- Sıvı yoğunluğu.
Yoğunluk, ρ g/cm³
veya kg/l olarak ölçülür.

TR- Otomatik test FEL57
(sıralama için sayfa 44, 45 ve
anahtarlama ünitesine bakın)

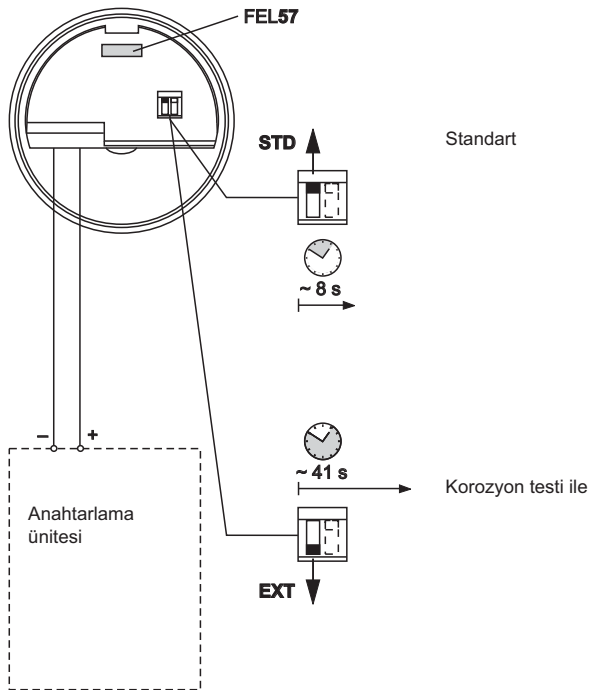

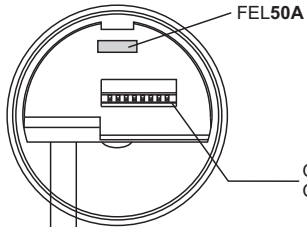

ON	1	2	4	8	16	32	64	SW
OFF	0	0	0	0	0	0	0	HW
	1	2	3	4	5	6	7	8

Örnek:

$2 + 8 = 10 = \text{Adres}$

TR- Cihaz adresinin ayarlanması
(Parametrelerin ayarlanması,
bakınız BA141F)

TR- Işık sinyalleri

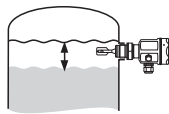

Değişkenlik seviyesi

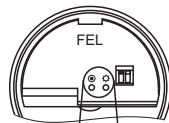

GN RD (YE)

LED'ler



Bekleme



Anahtarlama durumu



FEL57, FEL50A: Kapak



açık



yanıp sönüyor



kapalı



Çıkış sinyali



Hata



Ulusal düzenlemeleri dikkate alın

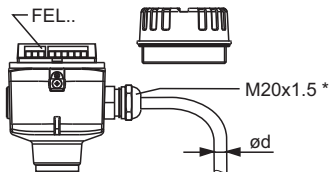

max. 2,5 mm²
(maks. AWG 14)

max. 4 mm²
(maks. AWG 12)

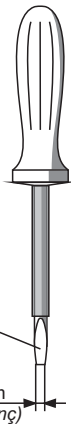
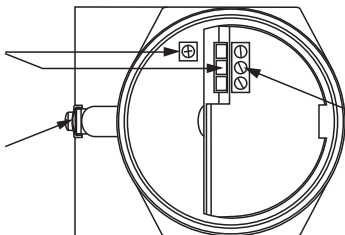

TR- Bağlantılar

*Kablo girişi

Nikel kaplamalı pirinç:

Ød = 7...10,5 mm (0,28...0,41 inç)

Plastik:

Ød = 5...10 mm (0,2...0,38 inç)

Paslanmaz çelik:

Ød = 7...12 mm (0,28...0,47 inç)

TR- Bağlantılar FEL51
İki telli AC bağlantısı

Devreden çıkarılması

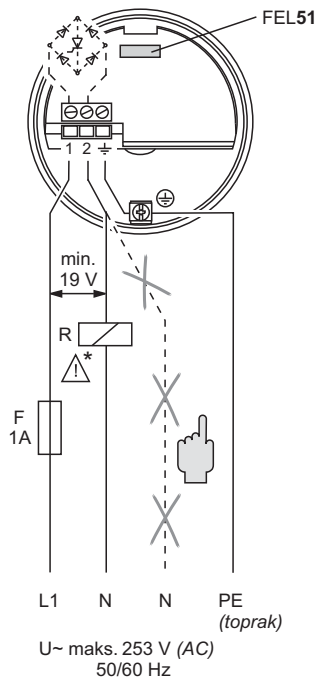

! * Harici yük R
bağlanmalıdır

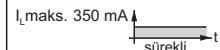
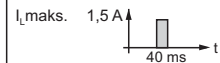

maks. 89 VA / 253 V
maks. 8,4 VA / 24 V

min. 2,5 VA / 253 V (10 mA)
min. 0,5 VA / 24 V (20 mA)

FEL51

TR- Fonksiyon FEL51

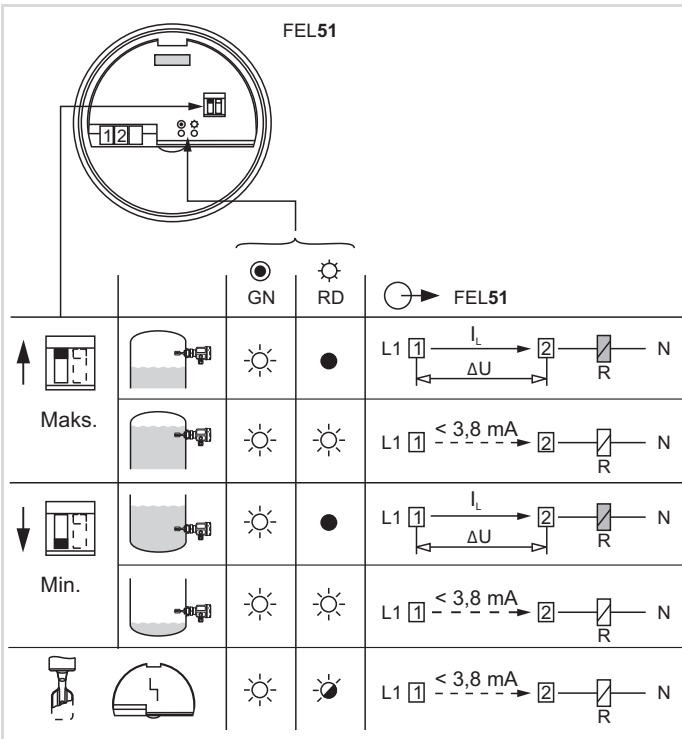

ΔU_{FEL51} maks. 12 V

TR- Bağlantılar FEL52
DC bağlantısı (PNP)

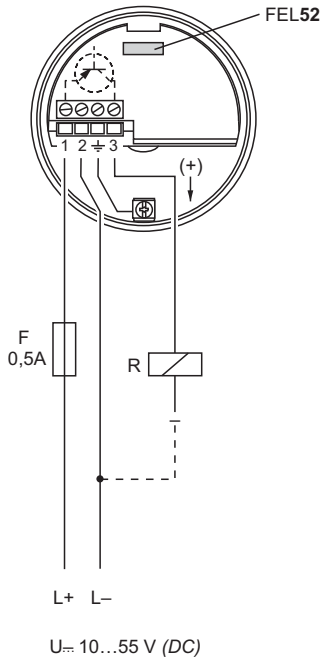

ayrıca DI modülleri için

EN 61131-2

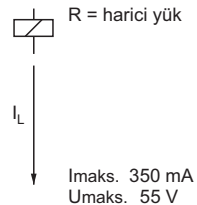

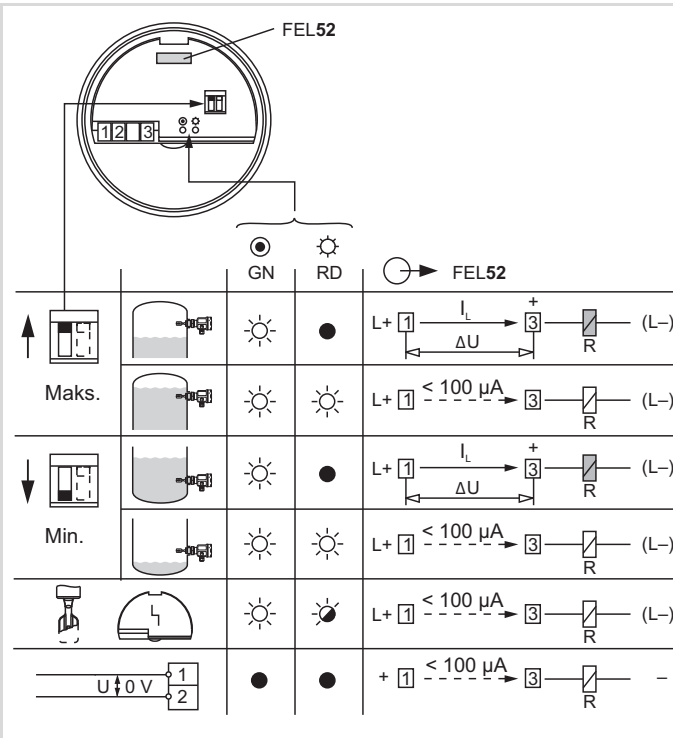

ΔU_{FEL52} maks. 3 V

TR- Bağlantılar FEL54
 Üniversal bağlantı
 Röle çıkışı

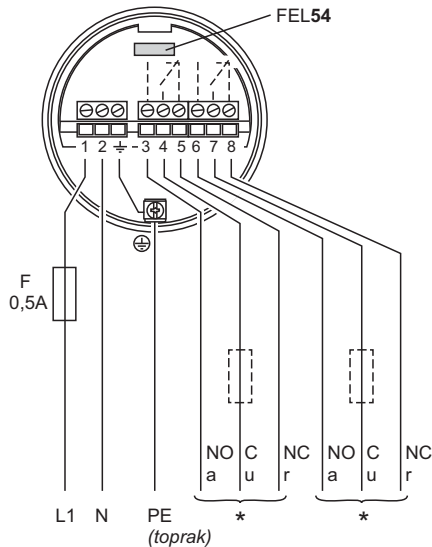

U~ 19...253 V (AC)

L+ L-
 U= 19... 55 V (DC)

{ U~ maks. 253 V, I~ maks. 6 A
 P~ maks. 1500 VA, $\cos \varphi = 1$
 * P~ maks. 750 VA, $\cos \varphi > 0,7$
 I= maks. 6 A, U- < 30 V
 I= maks. 0.2 A, U- < 125 V

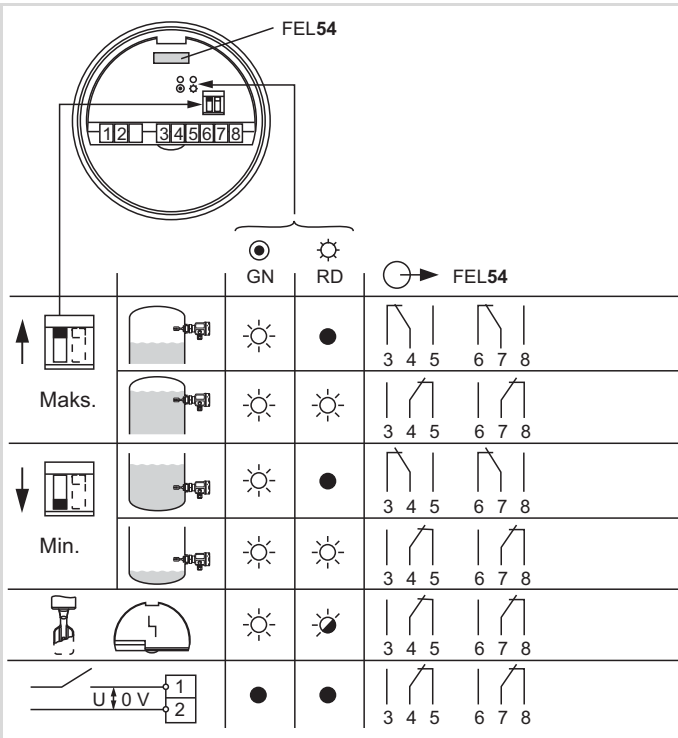

TR- Bağlantılar FEL55

Çıkış 8/16 mA

* Islak konum.

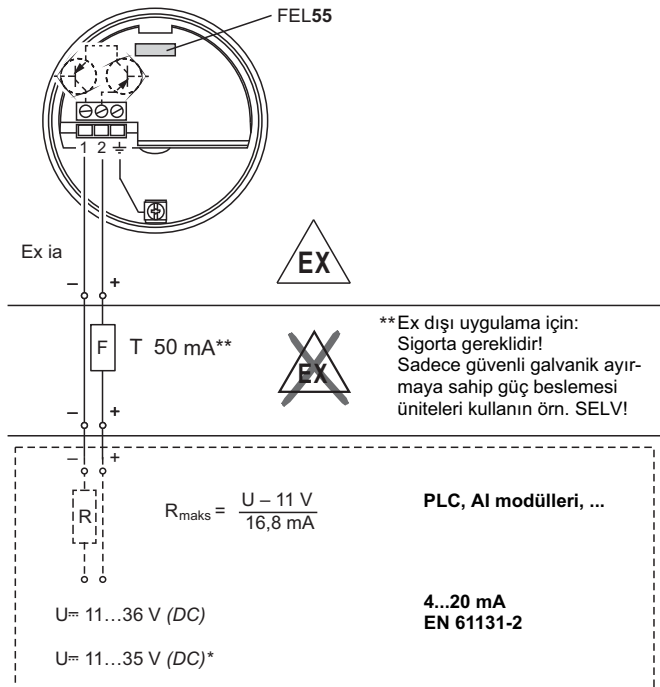

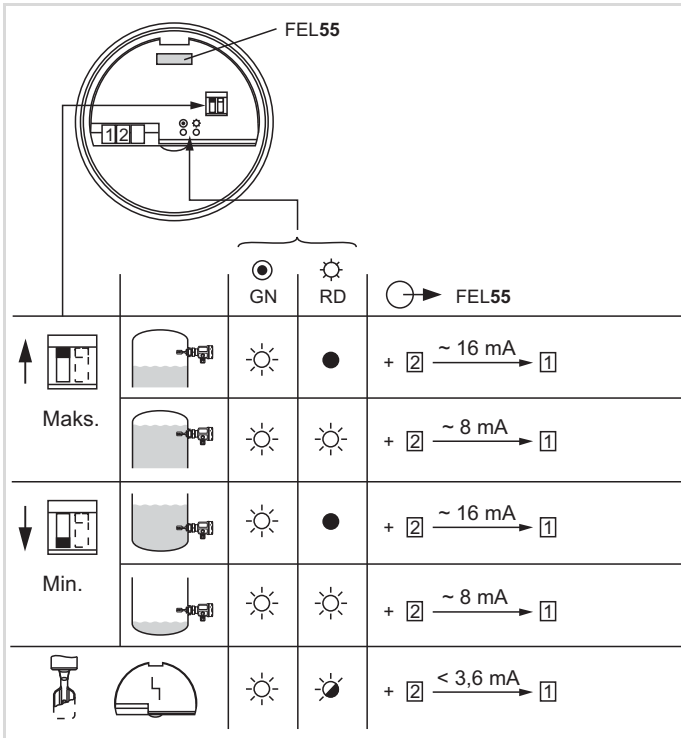

TR- Bağlantılar FEL56
NAMUR çıkış L-H
< 1,0 mA / > 2,2 mA

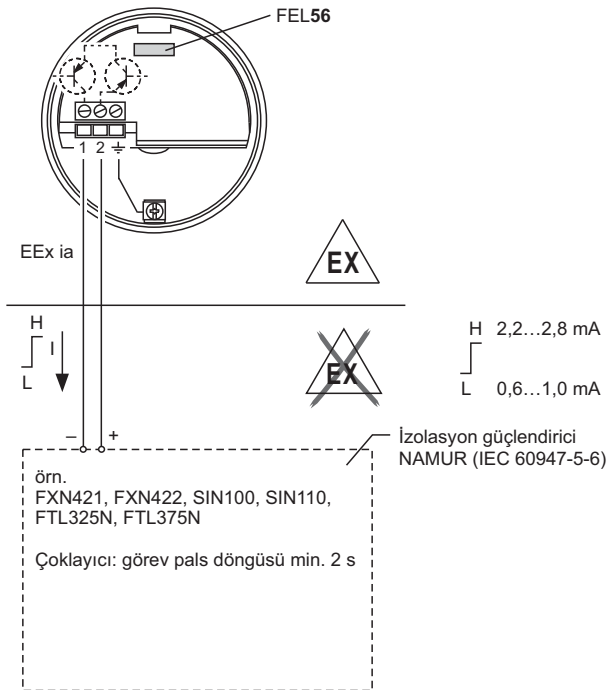

Güç beslemesi



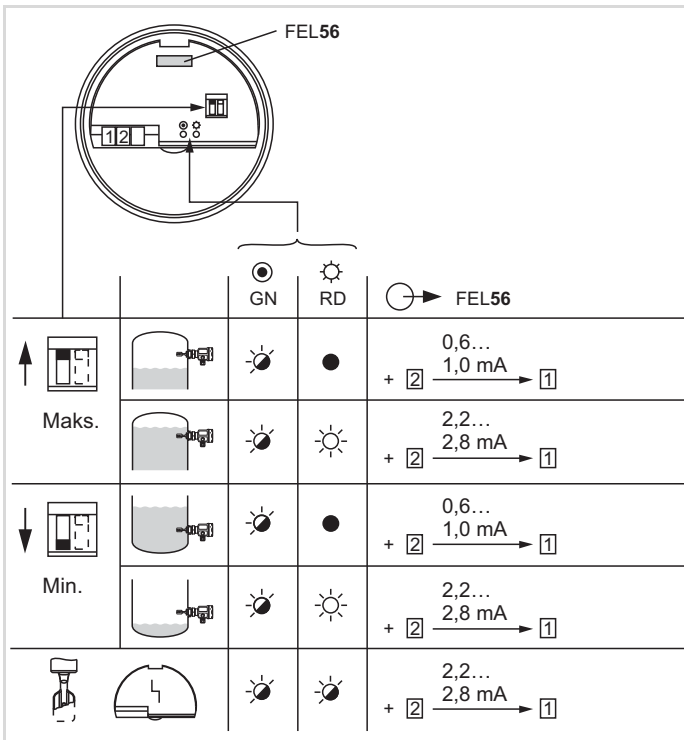



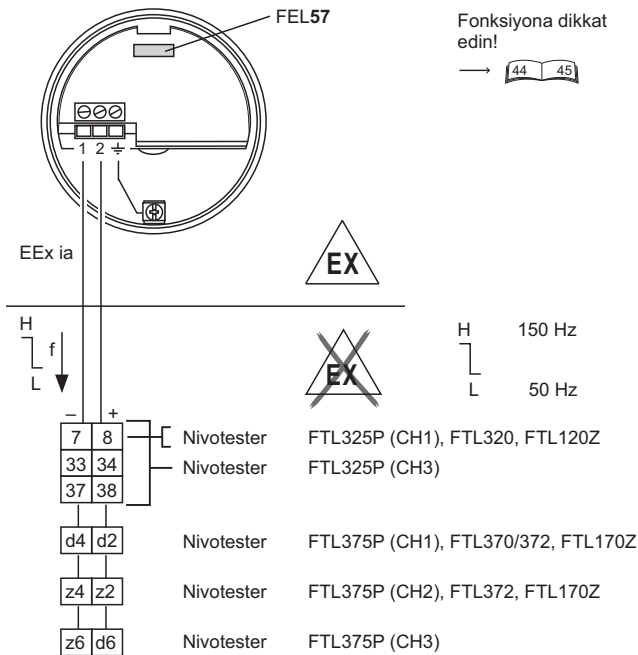

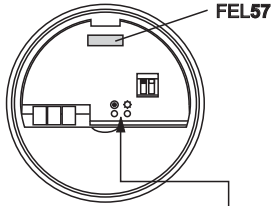





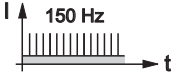

DC: 8,2 V +/- %20

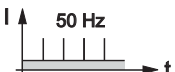

TR- Bağlantılar FEL 57
 PFM çıkış
 150 Hz / 50 Hz



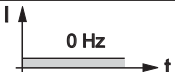
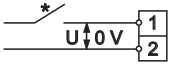

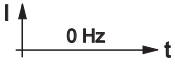
	 GN	 YE	 FEL57
			
			
			
			

* Açma durumu

TR- Açma durumu
Otomatik test (STD)

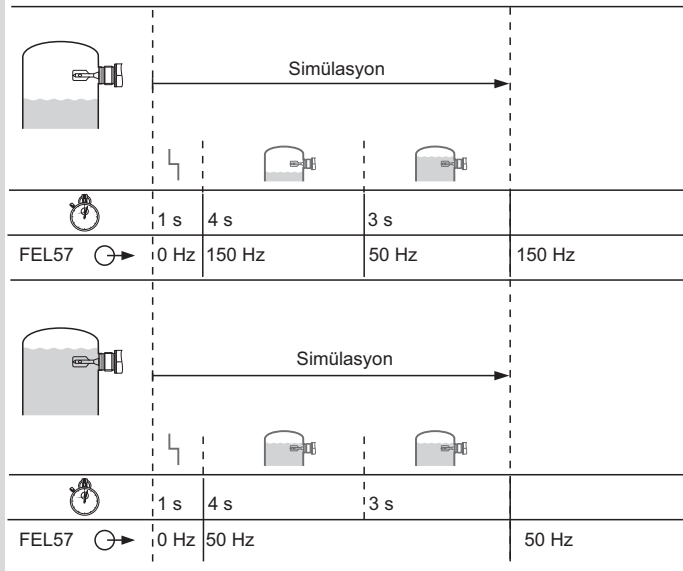
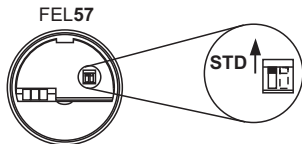

FEL57

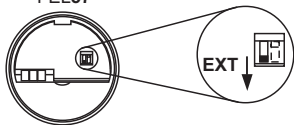

TR- Açma durumu
Otomatik test (EXT)

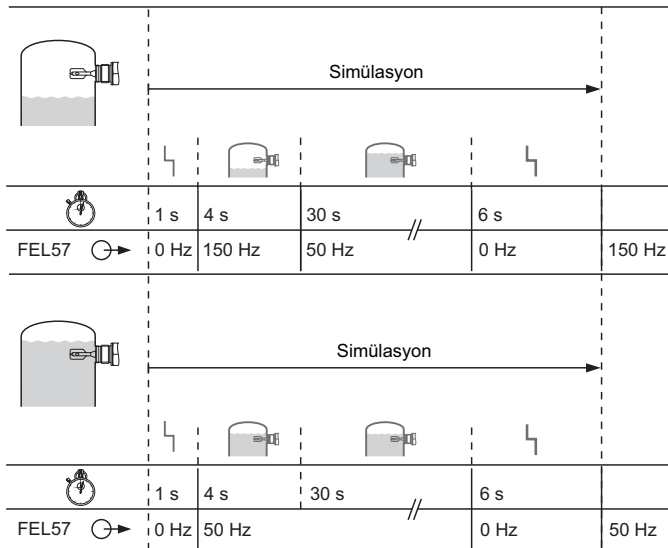

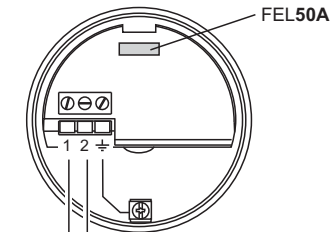



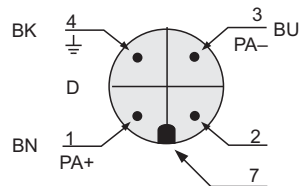



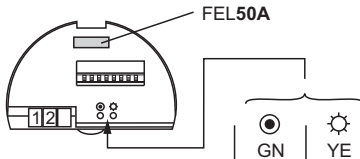













M12 fişi

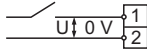

Muhafazada cihaz fişi (erkek)

				 FEL50A
		GN	YE	PA Bus Sinyali
çevrilmemiş				OUT_D = 0
				OUT_D = 1
çevrilmiş				OUT_D = 0
				OUT_D = 1
 SPS Commuwin II			-	İletişim
		-		Durum, bakınız BA141F
				../..

TR- Bağlantılar FEL58
NAMUR çıkış H-L
> 2,2 mA / < 1,0 mA

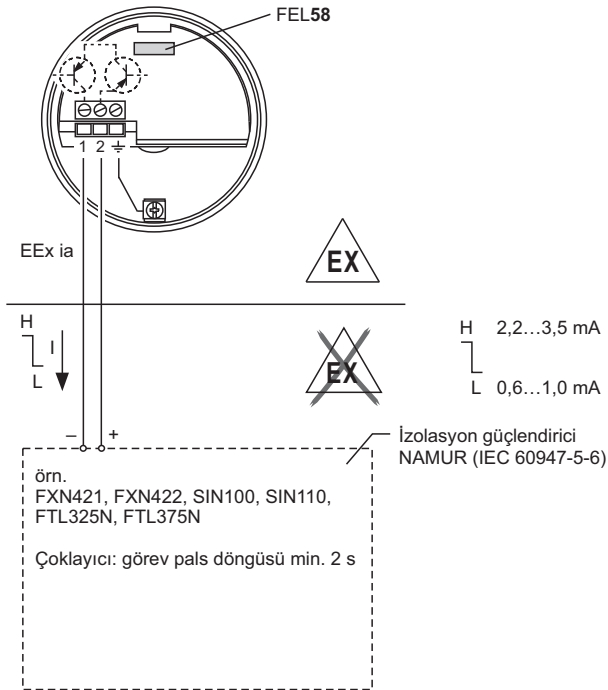





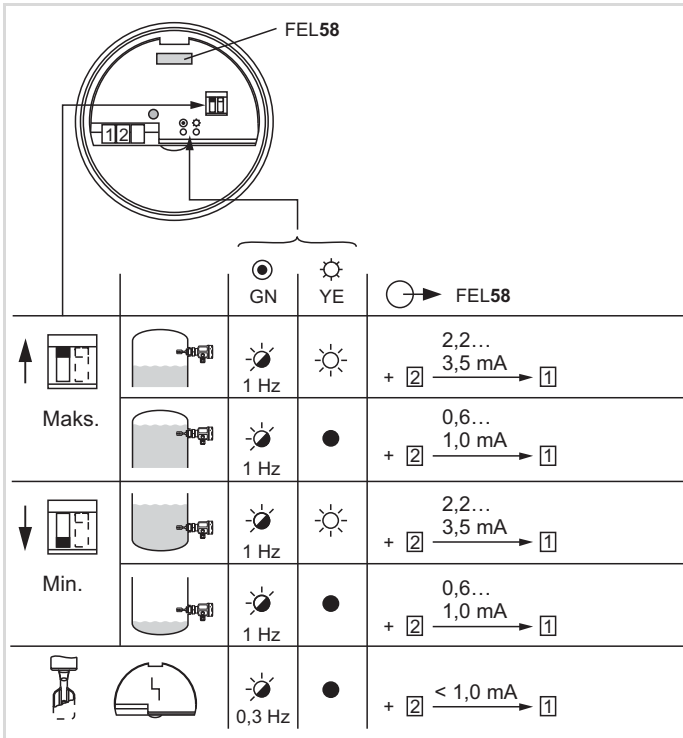



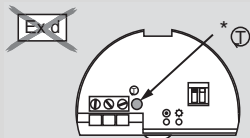









Güç beslemesi

DC: 8,2 V +/- %20



TR- Fonksiyon test butonu FEL58
Güvenlik modu MAX





<p>MAKS  + </p>		
<p>1. Normal çalışma</p>	<p>GN  YE  1 Hz + $\frac{2,2...}{3,5 \text{ mA}}$ → 1</p>	<p>GN  YE  1 Hz + $\frac{0,6...}{1,0 \text{ mA}}$ → 1</p>
<p>2. Test butonuna basın  >3 s</p>	<p>GN  YE  + 0 mA → 1</p>	<p>GN  YE  + 0 mA → 1</p>
<p>3. ~ 2 sn. normal çalışmadan sonra test butonunu bırakın </p>	<p>GN  YE  1 Hz + $\frac{2,2...}{3,5 \text{ mA}}$ → 1</p>	<p>GN  YE  1 Hz + $\frac{0,6...}{1,0 \text{ mA}}$ → 1</p>

TR- Fonksiyon test butonu FEL58
Güvenlik modu MIN

MIN  + 



1. Normal çalışma

GN YE
 
1 Hz

GN YE
 
1 Hz

+ 2,2...
3,5 mA → 1

+ 0,6...
1,0 mA → 1

2. Test butonuna basın



GN YE
 



GN YE
 

+ 0 mA → 1

+ 0 mA → 1

3. ~ 2 sn. normal çalışmadan sonra test butonunu bırakın



GN YE
 
1 Hz

GN YE
 
1 Hz

+ 2,2...
3,5 mA → 1

+ 0,6...
1,0 mA → 1

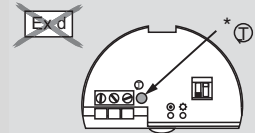

TR- Bakım, Temizlik

Kireç giderme

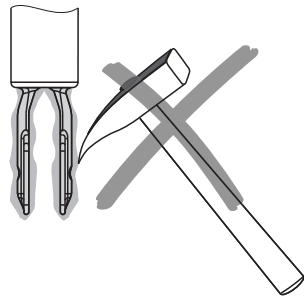
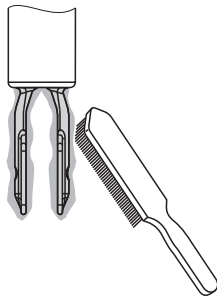

Basamak olarak
kullanmayın!

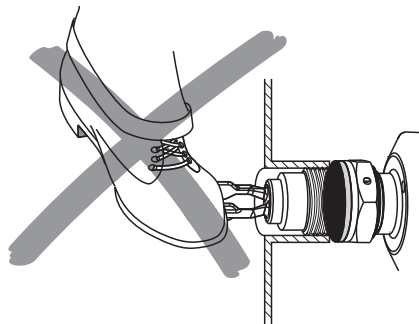

TR- Teknik Veriler

Ortam sıcaklığı T_a

İşlem sıcaklığı T_p

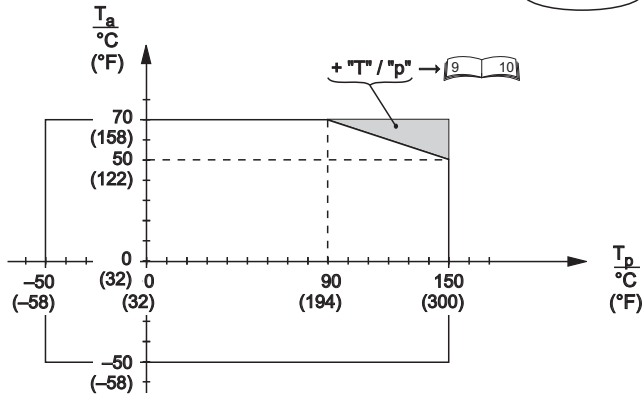
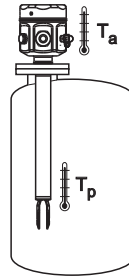

TR- İşlem basıncı p_e
İşlem sıcaklığı T_p

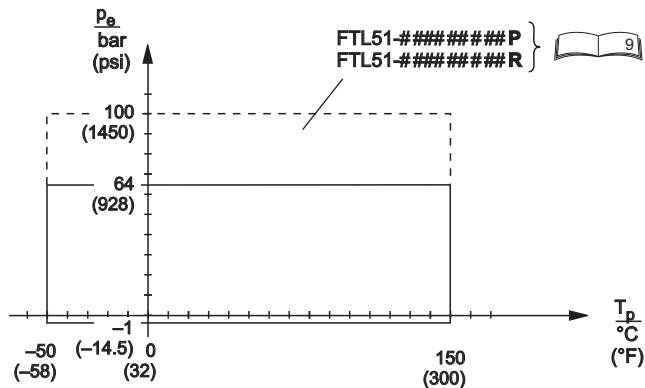

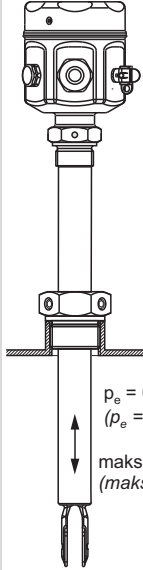

G 1
52003978

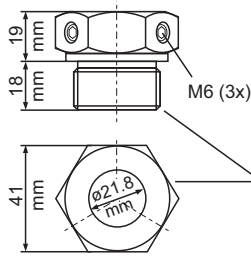

NPT 1 - 1 1/2
52003979

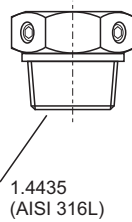

G 1 1/2
52003980

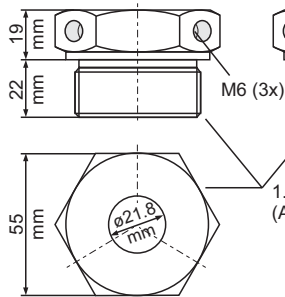

NPT 1 1/2 - 1 1/2
52003981

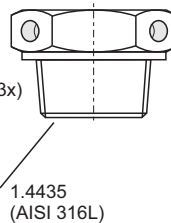

TR- Aksesuarlar

Basıncsız işlem için kayar
manşonlar

bakınız :

KA00151F (G 1, NPT 1)

KA00152F (G 1 1/2, NPT 1 1/2)

100 mm = 3, 94 inç

TR- Yüksek basınçlı kayar manşonlar

bakınız :
KA00153F (G 1, NPT 1)
KA00154F (G 1½, NPT 1½)

100 mm = 3, 94 inç

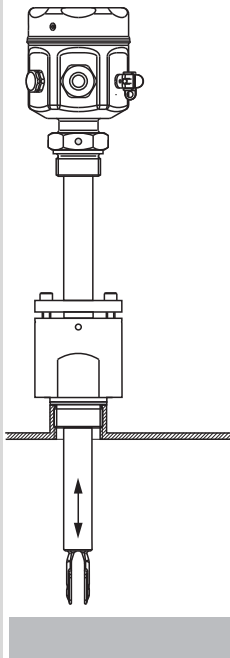

G 1

1.4435 (AISI 316L)
52003663

AlloyC4: 52003664
AlloyC22: 71118691

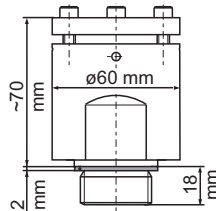

NPT 1 - 1½

1.4435 (AISI 316L)
52003667

AlloyC4: 52003668
AlloyC22: 71118694

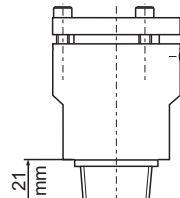

G 1½

1.4435 (AISI 316L)
52003665

AlloyC4: 52003666
AlloyC22: 71118693

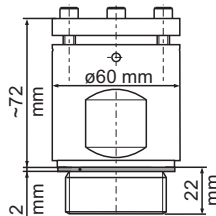

NPT 1½ - 1½

1.4435 (AISI 316L)
52003669

AlloyC4: 52003670
AlloyC22: 71118695

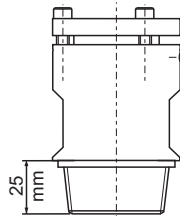

TR- Yüksek basınçlı kayar manşonlar:
İşlem basıncı p_e
İşlem sıcaklığı T_p

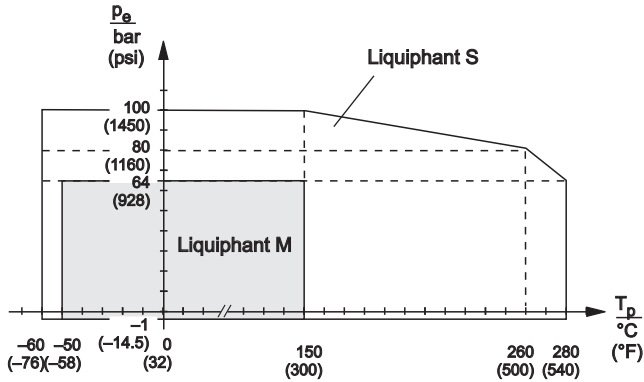

Hata	SebeP	Çözüm
Açılmıyor	Elektrik yok	Gücü kontrol edin
	Arızalı sinyal hattı	Sinyal hattını kontrol edin
	Arızalı elektronik takılması - FEL51, doğrudan L1 ve N'ye bağlı	Değiştirin - FEL51'i daima harici yük ile bağlayın
	Sıvının yoğunluğu çok az	Elektronik uçta yoğunluğu > 0,5 olarak ayarlayın
	Çatal kireçlenmiş	Çatalı temizleyin
	Çatal paslanmış (FEL'de gösterge: kırmızı/sarı ışık yanıp söner, FEL58: yeşil yanıp söner 0,3 Hz)	Çatalı değiştirin ve bağlantıya devam edin
	FEL51: Bağlanan rölenin iç direnci çok geniş	Uygun bir röle bağlayın
	FEL51: Bağlanan rölenin tutma akımı çok düşük	Rezistörü röle ile paralel bağlayın
	FEL54: Kontaklar kaynamış (kısa devreden sonra)	FEL54'ü değiştirin; kontak devresine sigorta koyun
Yanlış anahtarlama yapıyor	Min/Maks. güvenlik modu yanlış ayarlanmış	Elektronik ucun doğru modunu ayarlayın
Ara sıra arıza veren anahtarlama	Kalın ağır köpük, çok çalkalandığı durumlarda, köpük sıvısı	Liquiphant'ı by-pass şeklinde monte edin
	Harici RFI	Blendajlı kablo kullanın
	Harici titreşim	Çatalı sökün, devreden çıkarn, 90° çevirin
	Muhafazada su	Kapağı ve kablo rakorunu iyice vidalayın
	FEL52: Çıkışa aşırı yüklenilmiş	Yükü azaltın, (kablo) kapasitesi
Elektrik kesintisinden sonra yanlış anahtarlıyor	FEL57, açma testi sırasında durum (fonksiyon testi)	FEL57 anahtarlama durumunu kontrol edin; elektrik kesintisinden sonratesis kontrolünü en fazla 45 sn kadar durdurun

TR- Sorun Giderme Eki

Çatalın anahtarlama durumunda bir anormallik varsa çatal frekansı, teşhis soketinin PIN 4'ünde ölçülebilir.

Elektronik uçlar FEL51/52/54/55/56/57/58 ile birlikte bu, genliği çatalın durumunu belirlemeye mümkün hale getiren bir sinüzoidal titreşimdir.

FEL50A ile birlikte , dikdörtgen pals sinyalinden dolayı sadece çatal frekansının ölçümü yapılabilir.

TR- Yedek parçalar

Elektronik uçlar



FEL51	52002304
FEL52	52002305
FEL54	52002306
FEL55	52002307
FEL56	52002308
FEL57	52002309
FEL58	52006454
FEL50A	52010527

Kurulum özellikleri: Kurulum sırasında, kendiliğinden güvenli olmayan devreler tarafından çalıştırılan elektronik kaynakların (elektronik uçların) kendiliğinden güvenli olan devreler ile bağlantıda **olmayacağını** lütfen unutmayın.

TR- Onarım
Endress+Hauser'de

1.

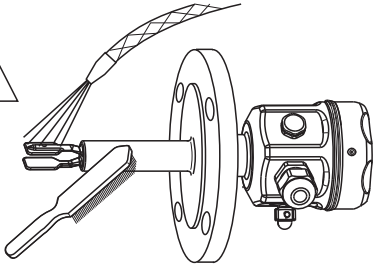

temizleyin

2.

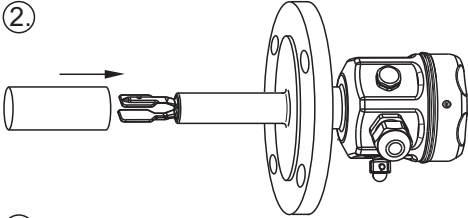

Taşıma
koruması

3.

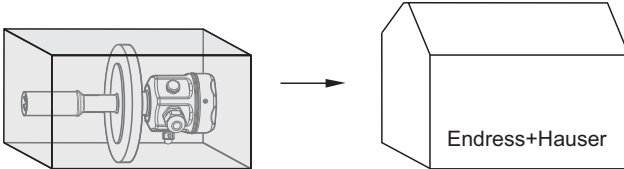

Endress+Hauser











Teknik Bilgiler

TI328F Liquiphant FTL50, FTL50H, FTL51, FTL51H
 TI426F Kaynak adaptörü, seviye ve basınç

Çalıştırma Talimatı

BA00141F FEL50A, PROFIBUS PA

Güvenlik Notları

XA00031F	CE 	II 1/2 G,	Ex d	IIC/IIB
XA00063F	CE 	II 1/2 G, II 1/2 D,	Ex ia/ib	IIC/IIB
XA00064F	CE 	II 1 G,	Ex ia	IIC/IIB
XA00108F	CE 	II 1/2 G,	Ex de	IIC/IIB
XA00113F	CE 	II 1/2 G,	Ex ia/ib	IIC
XA00114F	CE 	II 1/2 G,	Ex d	IIC
XA00115F	CE 	II 1/2 G,	Ex de	IIC
XA00154F	CE 	II 1/2 G, II 1/2 D,	Ex ia/ib	IIC/IIB
XA00158F	CE 	II 1/2 G,	Ex ia/ib	IIC
XA00159F	CE 	II 1 G,	Ex ia	IIC/IIB
XA00182F	CE 	II 3 G, II 3 D,	Ex nA/nC	IIC/IIIC



71420574

www.endress.com/worldwide
