

REGISTRY OF RADIOACTIVE SEALED SOURCES AND DEVICES
SAFETY EVALUATION OF A DEVICE
(AMENDED IN ITS ENTIRETY)

NO.: NR-1302-D-101-B

DATE: June 7, 2018

PAGE: 1 OF 29

DEVICE TYPE: Gamma Gauges

MODEL: QG 2000-xxxxxxx Series
FQG61 Series
FQG62 Series
FQG66 Series

DISTRIBUTOR: Endress + Hauser GmbH+Co.
Division Level + Pressure
2350 Endress Place
Greenwood, IN 46143

MANUFACTURER: Endress + Hauser GmbH+Co.KG
Hauptstrasse 1
D 79689 Maulburg
Germany

SEALED SOURCE MODEL DESIGNATION:

QSA Global Inc.	CKC.P4	Co-60	MA-1059-S-367-S
QSA Global Inc.	CKC.P6	Co-60	MA-1059-S-250-S
Eckert & Ziegler	Co0.P04	Co-60	CA-0406-S-228-S
Eckert & Ziegler	Co0.P03	Co-60	CA-0406-S-196-S
Eckert & Ziegler	Co0.P17	Co-60	CA-0406-S-195-S
Eckert & Ziegler	CDC.P4	Cs-137	CA-0406-S-249-S
QSA Global Inc.	CDC.93	Cs-137	MA-1059-S-368-S
QSA Global Inc.	CDC.800	Cs-137	MA-1059-S-200-S
Eckert & Ziegler	Cs7.P02	Cs-137	CA-0406-S-227-S
Eckert & Ziegler	Cs7.P04	Cs-137	CA-0406-S-228-S
Eckert & Ziegler	Cs7.P03	Cs-137	CA-0406-S-196-S
QSA Global Inc.	CDC.711M	Cs-137	MA-1059-S-232-S
Eckert & Ziegler	Cs7.P17	Cs-137	CA-0406-S-195-S
Eckert & Ziegler	Cs7.P13	Cs-137	CA-0406-S-195-S

ISOTOPE: MAXIMUM ACTIVITY:
Cobalt-60 5 Ci (185 GBq)
Cesium-137 10 Ci (370 GBq)

LEAK TEST FREQUENCY: 36 Months

PRINCIPAL USE: (D) Gamma Gauge

CUSTOM DEVICE: _____ YES _____ X NO

REGISTRY OF RADIOACTIVE SEALED SOURCES AND DEVICES
SAFETY EVALUATION OF A DEVICE
(AMENDED IN ITS ENTIRETY)

NO.: NR-1302-D-101-B

DATE: June 7, 2018

PAGE: 2 OF 29

DEVICE TYPE: Gamma Gauges

DESCRIPTION:

The QG and FQG source container series are used in combination with a gamma detector in measuring systems for fill level measurement, level limit detection, density and concentration measurement.

The QG and FQG series are intended for fixed installations and do not move during use. The QG 020, QG 100, FQG61 and FQG62 housings provide a flange to attach the source container to a vessel, a frame or a pipe. The QG 2000 **and FQG66** housings provide two mounting rails to attach the source container to a vessel, a frame or a pipe. For safe handling during installation, a ring eyelet or a lifting eye is attached to the housing. The source containers do not come into contact with the medium to be measured.

The following table identifies the source model, isotope and activity level that can be used in each of the QG Series gauges:

QG Series	Source Model	Isotope	Maximum Activity
QG 020	CKC.P4	Co-60	20 mCi (0.74 GBq)
QG 020	CKC.P6	Co-60	20 mCi (0.74 GBq)
QG 020	CDC.P4	Cs-137	500 mCi (18.5 GBq)
QG 020	CDC.93	Cs-137	600 mCi (22.2 GBq)
QG 100	CKC.P4	Co-60	100 mCi (3.7 GBq)
QG 100	CKC.P6	Co-60	100 mCi (3.7 GBq)
QG 100	CDC.P4	Cs-137	500 mCi (18.5 GBq)
QG 100	CDC.93	Cs-137	3 Ci (22.2 GBq)
QG 2000	CKC.P4	Co-60	2 Ci (74 GBq)
QG 2000	CKC.P6	Co-60	2 Ci (74 GBq)

Note: QG 020 & QG 100 Series were discontinued as of December 31, 2009. **The QG 2000 Series was discontinued with the issuance of the amendment dated June 7, 2018.**

Note: The activity of Co-60 authorized for the QG-2000 with CKC.P4 source model increased from 1 Curie to 2 Curies as of September 1, 2010.

REGISTRY OF RADIOACTIVE SEALED SOURCES AND DEVICES
 SAFETY EVALUATION OF A DEVICE
 (AMENDED IN ITS ENTIRETY)

NO.: NR-1302-D-101-B

DATE: June 7, 2018

PAGE: 3 OF 29

DEVICE TYPE: Gamma Gauges

DESCRIPTION (Cont.):

The "x" are used as place holders for the QG 020-xxxx and QG 100-xxxx Series, they represent Design, Process Connection (two digits), and emission angle as shown in the table below:

Design	Process Connection	Emission Angle
U - US Standard (incl. density modification)	P1 - DN100 PN16 flange, steel	A - 5°
J - US Pneumatic Actuator	P2 - DN100 PN16 flange stainless steel	B - 20°
K - US Fireproof	R1 - ANSI 4" 150 lb flange, steel	C - 40°
	R1 - ANSI 4" 150 lb flange, stainless steel	

The Standard Type for QG 020 and QG 100 Series is of a similar construction, which use identical safety and operation principles. They primarily consist of the following parts: Housing with integrated casted lead shielding, mounting flange with cover plate, display plate, source insert with locking source capsule.

The housing is of a welded construction and consists of the following parts welded together: Flange, spheroidal body, ring eyelet and insert holder. In case of QG 100 the body consists of two half shells welded together. The insert holder has the task to hold and secure the rotatable source insert, which has the function of a shutter mechanism.

The welded housing assembly is casted with lead and closed by the cover plate welded to the flange so that the lead screening is hermetically sealed. Plates at the inner wall of the spheroidal body prevent the lead screening from loosening.

REGISTRY OF RADIOACTIVE SEALED SOURCES AND DEVICES
SAFETY EVALUATION OF A DEVICE
(AMENDED IN ITS ENTIRETY)

NO.: NR-1302-D-101-B

DATE: June 7, 2018

PAGE: 4 OF 29

DEVICE TYPE: Gamma Gauges

DESCRIPTION (Cont.):

The emission channel is formed within the lead screening and is directed towards the mounting side. In the vertical plane, the emission angles 5°, 20° and 40° are available depending on the types of use, in the horizontal plane the emission angle is 6° independent of the model.

On the top of the housing, the display plate is welded to the insert holder. The stainless steel display plate carries the ON/OFF labels and optional labels, e.g. tag plates and provides locking holes to secure the source holder handle in the ON or OFF position.

The source insert, which is the main part of the shutter mechanism, is pivoted in the pipe of the insert holder. The source insert is of a welded construction and includes fixing parts for the source capsule. For operation and locking, a handle is welded to the upper part of the source insert.

To switch the source insert to the ON or OFF position it has to either manually or operated pneumatically be turned by 180°. The ON and OFF position is secured by a spring loaded locking bolt. Additionally, the source insert can be clamped by the non-safety relevant clamp screw. In the OFF position, the handle provides a hole matching up with a hole in the display plate to lock the source insert by a padlock. For safety reasons locking with the padlock is not possible in the ON position.

For the manually operated gauges the handle of the source insert also works as position indicator uncovering the words "ON" or "OFF" when in position, i.e. as one position is displayed the other is covered. ON and OFF labels use at least 6 mm (~ ¼ inch) high lettering and consist of anodized aluminum. The labels are fixed by screws or rivets to the display plate.

REGISTRY OF RADIOACTIVE SEALED SOURCES AND DEVICES
SAFETY EVALUATION OF A DEVICE
(AMENDED IN ITS ENTIRETY)

NO.: NR-1302-D-101-B

DATE: June 7, 2018

PAGE: 5 OF 29

DEVICE TYPE: Gamma Gauges

DESCRIPTION (Cont.):

The following table identifies the source model, isotope and activity level that can be used in each of the FQG61 and FQG62 Series gauges:

FQG Series	Source Model	Isotope	Maximum Activity in Device
FQG61	CKC.P4	Co-60	20 mCi (0.74 GBq)
FQG61	CDC.P4	Cs-137	500 mCi (18.5 GBq)
FQG61	CDC.93	Cs-137	600 mCi (22.2 GBq)
FQG61	CDC.800	Cs-137	300 mCi (11.1 GBq)
FQG61	Cs7.P02	Cs-137	500 mCi (18.5 GBq)
FQG61	Cs7.P04	Cs-137	600 mCi (22.2 GBq)
FQG61	Co0.P04	Co-60	20 mCi (0.74 GBq)
FQG62	CKC.P4	Co-60	100 mCi (3.7 GBq)
FQG62	CDC.P4	Cs-137	500 mCi (18.5 GBq)
FQG62	CDC.93	Cs-137	3 Ci (111 GBq)
FQG62	CDC.800	Cs-137	300 mCi (11.1 GBq)
FQG62	Cs7.P02	Cs-137	500 mCi (18.5 GBq)
FQG62	Cs7.P04	Cs-137	2 Ci (74.0 GBq)
FQG62	Co0.P04	Co-60	100 mCi (3.7 GBq)
FQG66	CKC.P4	Co-60	2 Ci (74 GBq)
FQG66	CKC.P6	Co-60	5 Ci (185 GBq)
FQG66	CDC.P4	Cs-137	500 mCi (18.5 GBq)
FQG66	CDC.93	Cs-137	3 Ci (111 GBq)
FQG66	CDC.711M	Cs-137	10 Ci (370 GBq)
FQG66	Cs7.P02	Cs-137	500 mCi (18.5 GBq)
FQG66	Cs7.P03	Cs-137	1 Ci (37 GBq)
FGQ66	Co0.P03	Co-60	1 Ci (37 GBq)
FQG66	Cs7.P04	Cs-137	5 Ci (185 GBq)
FQG66	Co0.P04	Co-60	5 Ci (185 GBq)
FQG66	Cs7.P13	Cs-137	100 mCi (3.7 GBq)
FQG66	Cs7.P17	Cs-137	10 Ci (370 GBq)
FQG66	Co0.P17	Co-60	4 Ci (148 GBq)

REGISTRY OF RADIOACTIVE SEALED SOURCES AND DEVICES
SAFETY EVALUATION OF A DEVICE
(AMENDED IN ITS ENTIRETY)

NO.: NR-1302-D-101-B

DATE: June 7, 2018

PAGE: 6 OF 29

DEVICE TYPE: Gamma Gauges

DESCRIPTION (Cont.):

The FQG61 and FQG62 Series models are derived from the existing QG-series. Safety concept, design, source capsules used and technical data are similar to the QG Series. FQG-61 replaces QG 020 and FQG62 replaces QG 100.

For model code details of the FQG61 and FQG62 Series and the model designations see Attachment 12.

The US Design version for FQG61 and FQG62 Series models are of similar construction to each other using identical safety and operation principles. The FQG61 and FQG62 Series models primarily consist of the following parts: housing with integrated casted lead shielding, mounting flange with cover plate, display plate, and source insert with locking source capsule.

The wall thickness of the housing for the FQG61 and FQG62 Series models is greater than or equal to 3 mm (0.12 in). The emission channel is approximately 9.5 mm (0.37 in) eccentric to the centerline of the housing.

The flange, spherical body and front plate have been constructed of coated steel or coated stainless steel. The insert holder and ring eyelet are constructed of stainless steel.

For manual operation and locking, a handle is welded to the upper part of the source insert. The rotatable source insert shutter with integrated chamber is designed to accommodate a double encapsulated source capsule. The source insert is sealed by an O-ring.

The display plate is screwed on the insert holder part of the housing. In the OFF position, the handle provides a hole matching up with a hole in the display plate to lock the source insert by a padlock. The ON position is secured by a spring-loaded locking bolt. The handle works as position indicator

REGISTRY OF RADIOACTIVE SEALED SOURCES AND DEVICES
SAFETY EVALUATION OF A DEVICE
(AMENDED IN ITS ENTIRETY)

NO.: NR-1302-D-101-B

DATE: June 7, 2018

PAGE: 7 OF 29

DEVICE TYPE: Gamma Gauges

DESCRIPTION (Cont.):

uncovering the words "ON" or "OFF" on the ON and OFF label when in position.

The FQG66 Series is a specifically licensed device and is derived from the previous QG 2000. The basic design of the housing, operating principles, and technical data are similar to the QG 2000. For model code details of the FQG66 Series and the model designations see Attachments 14 and 15.

The FQG66 Series models primarily consist of the following parts: cylindrical body with cylindrical compensation compartment, guide pipe with emission channel, ring eyelet for safe transport and installation, bearing for shutter mechanism, angle holder for attachment of the ON/OFF indicator, mounting rails, bridge for mounting the labels, and lead shielding.

The wall thickness of the housing for the FQG66 Series models is greater than or equal to 4 mm (0.157 in). The guide pipe, emission channel, and bearing of the shutter mechanism is designed in a way, that the way of the source from ON to Off position is 70 mm (2.755 in). The FQG66 Series include variations of the radiation emission channel: which includes horizontal or vertical direction, both optional for 5°, 20°, and 40° emission angle.

The FQG66 Series includes a manually operated version without proximity switches, a manually operated version with proximity switches, and a version with a pneumatic actuator. The purpose of the proximity switches is to determine whether the FQG66 Series is in the open or closed position.

The pneumatic actuator is a single-acting pneumatic cylinder. The actuating pressure range is 3.5 to 7 bar (51 psi to 101 psi) with a safety maximum pressure of 10 bar (145 psi). In case of pressure loss, the spring turns the shutter mechanism in the OFF position.

REGISTRY OF RADIOACTIVE SEALED SOURCES AND DEVICES
SAFETY EVALUATION OF A DEVICE
(AMENDED IN ITS ENTIRETY)

NO.: NR-1302-D-101-B

DATE: June 7, 2018

PAGE: 8 OF 29

DEVICE TYPE: Gamma Gauges

DESCRIPTION (Cont.):

In case of failure of the pneumatic actuator in the ON position, the actuator can be detached by disassembly of the allen screw. After removal of the screw, the source holder rod can be moved manually in the OFF position (identical function as the manual versions).

An indicator plates works as the position indicator uncovering the words "ON" or "OFF" of the ON/OFF label when in position, (i.e. as one position is displayed the other is covered). The ON/OFF label is visible through the glass windows of the protective hood. The protective hood protects the shutter mechanism against environmental influences, i.e. dust and water ingress.

To limit the travel of the source holder and prevent the source holder rod from being remove the source holder road is connected to a plain bearing bushing. The plain bearing bushing also extends through a slot in the Angle Holder. The plain bearing bushing is fixed into this slot by an indicator plate attached to the opposite side of the Angle Holder. The slot limits the travel of the source holder rod and acts as a stop when the source is pulled back into the open position. This also prevents the source holder rod from being removed.

The design of the shutter and shutter locking for the FQG66 is the same as the QG2000. The FGQ66 will be shipped with a lock on the cover over the shutter shaft. To commission the unit the lock is removed from the cover (protective hood) and stored on the shutter shaft. It can lock the shutter in the closed position. If the lock is removed the shutter can be opened. It is not possible to lock the shutter in the open position. The lock is stored in the hold on the shutter shaft. The lock will not fit through anything but the shaft in the open position. The shaft can still be slid into the closed position. Once closed the lock can secure the shutter shaft closed. Once the shutter is positioned correctly the cover can be replaced.

REGISTRY OF RADIOACTIVE SEALED SOURCES AND DEVICES
 SAFETY EVALUATION OF A DEVICE
 (AMENDED IN ITS ENTIRETY)

NO.: NR-1302-D-101-B

DATE: June 7, 2018

PAGE: 9 OF 29

DEVICE TYPE: Gamma Gauges

DESCRIPTION (Cont.):

The overall dimensions of FQG66 are as follows:

Source Container Module	Weight	Dimensions
FQG66 manually operated	Maximum 435 kg (959.2 lb)	L: 780 mm (28.7 in) W: 335 mm (13.2 in) H: 456 mm (18 in) including ring eyelet
FQG66 With pneumatic actuator		L: 833 mm (32.8 in) W: 390 mm (15.4 in) including connection box H: 456 mm (18 in) including ring eyelet

The Fire Proof version for the QG 020 and QG 100 Series is entirely based upon the standard version. The difference to the standard type is that the housing has an additional compensation compartment, which compensates the increased volume required by liquefied lead in case of fire.

The compensation compartment is welded laterally onto the housing. Its volume depends on the volume of the type of the source container and its material is identical to the material of the housing. The compensation compartment is connected with the lead shielding inside the housing through two boreholes. Similar to the standard type the lead shielding is hermetically sealed.

The Fire Proof version for the FQG61 and FQG62 Series is based upon the US Design version or the pneumatic version.

REGISTRY OF RADIOACTIVE SEALED SOURCES AND DEVICES
SAFETY EVALUATION OF A DEVICE
(AMENDED IN ITS ENTIRETY)

NO.: NR-1302-D-101-B

DATE: June 7, 2018

PAGE: 10 OF 29

DEVICE TYPE: Gamma Gauges

DESCRIPTION (Cont.):

The heights in the Fire Proof versions differ due to the inclusion of the varying sizes of the upper assembly between the US Design versions and the pneumatic versions of the FQG61 and FQG62 Models. These heights vary from 287 mm to 508 mm.

The construction of the QG 020 and QG 100 with a Pneumatic Actuator is based upon the standard version. Up to the insert holder, the construction including the fixation of the source capsule is entirely identical to the standard version.

On the top of the source container housing, instead of the shutter handle, the actuator adapter cylinder is fastened. It carries the pneumatic actuator, two optional electrical initiators with terminal box, the labels and the locking measures. The actuator adapter cylinder is a welding construction attached to the insert holder by three stainless steel screws, which have coated threads against loosening. The arrangement of the screws ensures correct mounting of the actuator assembly regarding the ON/OFF position.

For fixing of the label and the optional terminal box to the outside of the cylinder two plates are welded on. The internal volume of the adapter cylinder is sealed by an O-ring located between the source container housing and the adapter cylinder, by sealing compound and by U-seal disks applied to components screwed on.

The pneumatic actuator is a spring-loaded type with a swivel range of 180°. The actuating pressure range is 3.5 to 6 bar (51 psi to 87 psi). In case of pressure loss, the spring turns the shutter mechanism in the OFF position. The operational torque range of the actuator is 3.8 to 10.4 Nm (33.6 to 92 in-lb).

REGISTRY OF RADIOACTIVE SEALED SOURCES AND DEVICES
SAFETY EVALUATION OF A DEVICE
(AMENDED IN ITS ENTIRETY)

NO.: NR-1302-D-101-B

DATE: June 7, 2018

PAGE: 11 OF 29

DEVICE TYPE: Gamma Gauges

DESCRIPTION (Cont.):

In case of failure of the pneumatic actuator in the ON position, the source insert can be turned manually into the OFF position. For this, the lower padlock has to be opened and the Allen screws affixing the actuator adapter cylinder must be unscrewed. After this, the complete actuator unit can be removed and the upper part of the source insert is accessible for manual operation and adjacent to the source insert an ON/OFF marking is visible.

The pneumatic actuator assembly may also be combined with the source container housing of the Fire Proof version.

The inserts, which contain the source capsule, are identical to the manually operated inserts, except the upper end, which is modified to connect the pneumatic actuator by an adaptor. The adaptor is firmly attached to the source insert by a bolt and has a four-cornered shaft at its upper end as connection to the actuator. The source insert is locked by an arrester, which ensures that the insert cannot be removed by mistake in case of e.g. exchange or maintenance of the pneumatic drive.

The pneumatic standard design for the FQG61 and FQG62 Series is based upon the US Design version. The shutter operated by the pneumatic actuator is connected to the source insert by a square shaft. The rotatable source insert shutter with integrated chamber is designed to accommodate a double encapsulated source capsule. **The FQG61 and FQG62 Series can support two different types of actuators.**

An adapter ring provides locking against unintentional extraction of the source insert after disassembly of the actuator adapter housing.

For the pneumatic versions of the FQG61 and FQG62 Series, a sealing compound is used between the actuator and the adapter cylinder and between the proximity switches and the adapter cylinder to seal the parts.

REGISTRY OF RADIOACTIVE SEALED SOURCES AND DEVICES
SAFETY EVALUATION OF A DEVICE
(AMENDED IN ITS ENTIRETY)

NO.: NR-1302-D-101-B

DATE: June 7, 2018

PAGE: 12 OF 29

DEVICE TYPE: Gamma Gauges

DESCRIPTION (Cont.):

A padlock fits into overlapping boreholes of the lugs welded to the adapter cylinder and the adapter ring. A padlock fits into overlapping boreholes of the two round display plates of the ON/OFF indicator.

All components are made of uncoated stainless steel, except the padlocks, pneumatic actuator, proximity switches and terminal box.

For the FQG61 and FQG62 Series models, in OFF position the source capsule is located behind the lead screening, i.e., radiation cannot be emitted directly through the radiation emission channel. By turning the source insert to the ON position, the source capsule is moved into the eccentrically positioned emission channel.

For securing the insert holder for the FQG61 and FQG62 Series models, the cylinder bolt of the source insert extends into the circular groove of the insert holder. This prevents movement of the source insert out of its bearing. Only when the cylinder bolt is in this position of the cut-out, the source insert can be detached from the housing (removal position). The removal position is blocked by locking measures (e.g. locking pin) to prevent unintentional switching to removal position. The source insert area and the area of the source capsule for the FQG61 and FQG62 Series models are sealed against the environment by O-rings and similar sealing measures.

REGISTRY OF RADIOACTIVE SEALED SOURCES AND DEVICES
SAFETY EVALUATION OF A DEVICE
(AMENDED IN ITS ENTIRETY)

NO.: NR-1302-D-101-B

DATE: June 7, 2018

PAGE: 13 OF 29

DEVICE TYPE: Gamma Gauges

DESCRIPTION (Cont.):

For the QG 2000-xxxxxxx, the placeholders represent Model, Shielding, Fitting Position/Emission Angle, Emission Angle, Material/Surface Treatment, Additional Option and Documentation.

Model	Shielding	Fitting Position/ Emission Angle	Emission Angle	Material/ Surface Treatment	Additional Option	Documentation
V US, manual On/Off	1 - Standard Shielding	A - standing/horizontal	1 - 20°	A - SS 316 TI (1.4571), glass bead blasted	1 - option not selected	A - No Documentation
W US, manual On/Off, remote indication		B - standing/vertical	2 - 40°	.. - Any single letter or number representing SS 316 TI (1.4571) plus additional surface treatment (e.g. coating, painting)	S - GL marine certificate	.. any single letter or number representing additional documentation (e.g. isodose curve, GL registration)
			3 - Customized Specified in 5° steps (α and β), α: 0° to 45° β: 0° to 75°			

QG 2000 consists of the following parts: housing with integrated casted lead shielding, protective hood, mounting rails, source support bar with locking and indication measures, and source capsule.

For the FQG61 and FQG62 Series models, the model designation system is shown in Attachment 12.

At this model the radiation beam is switched ON/OFF by moving the source support bar axially to its end positions. The shutter mechanism, its locking measures as well as the ON/OFF indication labels are covered by a protective hood, which can be locked at the locking plate with a padlock.

REGISTRY OF RADIOACTIVE SEALED SOURCES AND DEVICES
SAFETY EVALUATION OF A DEVICE
(AMENDED IN ITS ENTIRETY)

NO.: NR-1302-D-101-B

DATE: June 7, 2018

PAGE: 14 OF 29

DEVICE TYPE: Gamma Gauges

DESCRIPTION (Cont.):

All parts and components of the source container are made of stainless steel. The housing is a welded construction and consists of the following parts welded together: Mounting Rails, cylindrical body, lifting eye and emission channel assembly with guide pipe for the source support bar.

The emission channel is formed by sheet metal parts within the lead screening. Depending on the specific type, the emission channel is directed radially to or rectangular to the mounting rails. In the first case the opening angle is either 20° or 40°, in the latter case the opening angle is either 20° or 40° as a standard or customized from 5° to 120°. The axial opening angle is always 6° independent of the type. The area of the emission window is indicated on the surface by the sheet metal strip closing the emission channel.

Between the body of the housing and the protective hood a compensation compartment is located to compensate increased volume required by liquefied lead in case of fire. This compartment is an integral part of the housing.

The welded housing assembly is casted with lead and closed by the cover plate welded to the compensation compartment and the guide pipe so that the lead screening is hermetically sealed to the ambient. On the bottom of the housing body, two mounting rails reinforced by cross braces are welded to the exterior wall, on the top a lifting eye is welded on for safe handling. The protective hood is fastened on the cover plate by two stainless steel Allen screws using the bayonet lock principle. Each screw is secured against losing by a small bolt. Between the hood and the plate an O-ring seal is applied, the windows of the ON/OFF indication are sealed by gaskets.

The source holder rod consists of the source support rod and its protective tube connected by a thread. The source capsule is located on the tip of the rod and is completely covered by the protective tube, which is sealed to the ambient by two O-ring

REGISTRY OF RADIOACTIVE SEALED SOURCES AND DEVICES
SAFETY EVALUATION OF A DEVICE
(AMENDED IN ITS ENTIRETY)

NO.: NR-1302-D-101-B

DATE: June 7, 2018

PAGE: 15 OF 29

DEVICE TYPE: Gamma Gauges

DESCRIPTION (Cont.):

seals. The source holder rod is located inside the guide pipe of the housing and can be moved axially to the ON or OFF position.

At the end of the source holder rod opposite to the source, the handle with the indication plate is screwed on. The indication plate has the task to cover the ON/OFF labels. Additionally the plate acts as a stop i.e. the source holder cannot get removed without dismantling of the cover plate. Both ON and OFF positions can be fixed by a fixing screw engaging into a hole of the protective tube.

In both positions, a crosshole through the source support rod and its protective tube overlaps with a crosshole of the guide pipe and allows the application of a padlock or a locking bolt for safety locking.

The procedure of switching and locking of the ON or OFF position is described in the operation manual and states "Do not lock source support bar with the padlock when in ON position" to the user. The function of the slider is to prevent access to the source holder rod in the ON position. As the rod could be removed after unscrewing the handle, the slider, which is movable along the handle only, covers the Allen screw of the handle and is blocked by the padlock when placed in its "stand-by position". In the OFF position, access to the source is restricted by the padlock. All parts of the source holder consist of stainless steel.

DIAGRAM:

See Attachments 1 to 15.

REGISTRY OF RADIOACTIVE SEALED SOURCES AND DEVICES
SAFETY EVALUATION OF A DEVICE
(AMENDED IN ITS ENTIRETY)

NO.: NR-1302-D-101-B

DATE: June 7, 2018

PAGE: 16 OF 29

DEVICE TYPE: Gamma Gauges

LABELING:

Each QG 020 and QG 100 gauge is labeled with a nameplate containing identification data of the source, unique serial number of the source container, manufacturer, dose rate at one meter, radionuclide, activity, the radiation trefoil and the wording "Caution Radioactive Material". The nameplate consists of stainless steel sheet metal (approximately 45 x 55mm / 1.73 inches x 2.12 inches) and is fixed by rivets or grooved studs on the source insert (standard and fireproof version) or on the housing (pneumatic version).

The ON and OFF position labels are riveted to the display plate (standard and fireproof version) or to the actuator (pneumatic version). Furthermore, each source container is marked with a radiation-warning label depicting the radiation trefoil and the wording "Caution - Radioactive Material". This label consists of triangular sheet metal and is affixed to the display plate by a stainless steel key ring.

Devices intended for distribution to generally licensed persons are labeled according to 10 CFR 32.51 with an additional label affixed to the display plate (standard and fireproof version) or to the ring eyelet (pneumatic version) by a stainless steel key ring. Optionally the source container may have a black radiation warning sign on its yellow coated or painted housing.

An additional adhesive label gives information about the source capsule, which is built in. The label shows the radiation trefoil and states the radionuclide, activity and date, serial number of the source and source container model. For the manually operated types, the label is attached to the source insert, at types with the pneumatic actuator one is attached on the actuator adapter cylinder and an additional one on the source insert.

For the QG 2000 each gauge is labeled with a nameplate containing identification data of the source, unique serial number of the source container, manufacturer, dose rate in one

REGISTRY OF RADIOACTIVE SEALED SOURCES AND DEVICES
SAFETY EVALUATION OF A DEVICE
(AMENDED IN ITS ENTIRETY)

NO.: NR-1302-D-101-B

DATE: June 7, 2018

PAGE: 17 OF 29

DEVICE TYPE: Gamma Gauges

LABELING (Cont.):

meter, radionuclide, activity, the radiation trefoil and the wording "Caution Radioactive Material". The nameplate consists of stainless steel sheet metal (approximately 44 mm x 80 mm / 1.73 inches x 3.15 inches) and is fixed by rivets or grooved studs on the mounting rail. The ON and OFF position labels are riveted to the display plate. Additionally each source container is marked with a radiation-warning label depicting the radiation trefoil and the wording "Caution - Radioactive Material". This label consists of triangular sheet metal and is affixed to the lifting eye by a stainless steel key ring.

Devices intended for distribution to generally licensed persons are labeled according to 10 CFR 32.51 with an additional label affixed to the lifting eye by a stainless steel key ring. An additional adhesive label is attached to the source support rod and gives information about the source capsule, which is built in. The label shows the radiation trefoil and states the radionuclide, activity and date, serial number of the source, source container model.

Each specifically licensed US Design FQG61, FQG62 gauge is labeled with a nameplate containing identification data of the source, unique serial number of the source container, manufacturer, radionuclide, serial number of source capsule, activity, the radiation trefoil, the wording "Caution Radioactive Material" and date. The nameplate consists of stainless steel sheet metal (approximately 45 mm x 55 mm / 1.77 inches x 2.16 inches) and is fastened with stainless steel round head grooved pins to the insert holder.

Each specifically licensed pneumatic standard design FQG61 and FQG62 gauge is labeled with a nameplate containing identification data of the source, unique serial number of the source container, manufacturer, radionuclide, serial number of source capsule, activity, the radiation trefoil, the wording "Caution Radioactive Material", and date. The nameplate consists of stainless steel sheet metal (approximately 43 mm x

REGISTRY OF RADIOACTIVE SEALED SOURCES AND DEVICES
SAFETY EVALUATION OF A DEVICE
(AMENDED IN ITS ENTIRETY)

NO.: NR-1302-D-101-B

DATE: June 7, 2018

PAGE: 18 OF 29

DEVICE TYPE: Gamma Gauges

LABELING (Cont.):

80 mm / 1.69 inches x 3.15 inches) and is fastened with stainless steel round head grooved pins to the insert holder. An alternate nameplate (approximately 45 mm x 55 mm) may be used. The alternate nameplate will contain the same information as the main nameplate.

The FQG61 and FQG62 Series devices, intended for distribution to generally licensed persons, are labeled according to 10 CFR 32.51 with an additional label affixed to the display plate (US Design and Fire Proof version) or to the ring eyelet (pneumatic version) by a stainless steel key ring. Optionally the source container may have a black radiation warning sign on its yellow coated or painted housing.

For the US Design of the FQG61 and FQG62 Series models, a radiation warning sign (adhesive label) is applied on the display plate. Another adhesive label on the front cover plate of the flange provides information to indicate the position of the radiation emission channel. A radiation warning sign is attached to the display plate by stainless steel key ring.

For the pneumatic standard design of the FQG61 and FQG62 Series models, a radiation warning sign (adhesive label) is applied on top of the pneumatic actuator. Also, an adhesive label on the front cover plate of the flange provides information to indicate the position of the radiation emission channel.

Each specifically licensed US Design FQG66 gauge is labeled with two nameplates containing identification data of the source, unique serial number of the source container, manufacturer, radionuclide, serial number of source capsule, activity, the radiation trefoil, the wording "Caution Radioactive Material" and date. The nameplates consists of stainless steel sheet metal (approximately 45 mm x 55 mm / 1.77 inches x 2.16 inches) and is fastened with stainless steel round head grooved pins to the insert holder. An additional name plate identifying the gauge distributor is also included, the label is also stainless

REGISTRY OF RADIOACTIVE SEALED SOURCES AND DEVICES
SAFETY EVALUATION OF A DEVICE
(AMENDED IN ITS ENTIRETY)

NO.: NR-1302-D-101-B

DATE: June 7, 2018

PAGE: 19 OF 29

DEVICE TYPE: Gamma Gauges

LABELING (Cont.):

steel and is approximately 50 mm x 60 mm/ 1.96 inches x 2.36 inches). The FQG66 gauge also includes an additional radiation warning sign the label is stainless steel and is attached by a stainless steel rope attached by crimp connection.

CONDITIONS OF NORMAL USE:

The QG Series and FQG Series devices are intended for industrial gauging applications such as fill level or density measurement at tanks, vessels or pipes. They are typically used in industrial process control environment. As the device is used in conjunction with a scintillation detector, it is usually the characteristics of the detector that sets the limit to the temperature range and to vibration and shock.

The normal temperature range for the QG Series and **FQG61 and FQG62** Series source containers are from -40 °C to 200 °C. Use of initiators with the QG 2000 reduces the upper limit of this range to 100 °C. Use of pneumatics with the QG Series and FQG Series further reduces the upper limit of this range to 80 °C and for the FQG Series increases the lower limit of the range to -20 °C.

The normal range of the pneumatic supply pressure is 3.5 to 6 bar.

The normal temperature range for the **FQG66** Series source containers are from -55 °C to 100 °C for the manually operated version and from -20 °C to 80°C for the versions that are manually operated with proximity switches or with the pneumatic actuator. The **FQG66** Series should be limited to mild to medium vibration.

The expected useful working lifetime of the QG 020, QG 100, QG 2000, **FQG61, FQG62, and FQG66** source containers is 20 years.

REGISTRY OF RADIOACTIVE SEALED SOURCES AND DEVICES
 SAFETY EVALUATION OF A DEVICE
 (AMENDED IN ITS ENTIRETY)

NO.: NR-1302-D-101-B

DATE: June 7, 2018

PAGE: 20 OF 29

DEVICE TYPE: Gamma Gauges

PROTOTYPE TESTING:

The QG Series and FQG Series devices were subjected to vibration and shock tests, as well as fire tests. The gauges were also subjected to a 27-foot drop tests. Endress + Hauser provided the prototype test results. The versions with the shutter mechanism were also subjected to cyclical tests.

EXTERNAL RADIATION LEVELS:

The following are the dose rates reported by the manufacturer for the QG 020, QG 100 and QG 2000 Series gauges. The calculation in front of the flange for the QG 020 and QG 100 or in front of the window for the QG 2000 depicts the radiation levels when the shutter is in the closed position. The highest calculation is taken from the highest value around the spherical housing independent of whether the shutter is in the open or closed position.

QG 020-xxxx with 0.74 GBq (20 mCi) of Co-60

Distance	Maximum Radiation Level			
	From Spherical Housing		From Flange (shutter closed)	
(cm)	µSv/hr	mrem/hr	µSv/hr	mrem/hr
5	537	53.7	339	33.9
30	61.6	6.61	52	5.2
100	97	0.97	9.7	0.97

QG 020-xxxx with 22.2 GBq (600 mCi) of Cs-137

Distance	Maximum Radiation Level			
	From Spherical Housing		From Flange (shutter closed)	
(cm)	µSv/hr	mrem/hr	µSv/hr	mrem/hr
5	803	80.3	413	41.3
30	93.6	9.36	41.6	4.16
100	11.7	1.17	5.9	0.59

REGISTRY OF RADIOACTIVE SEALED SOURCES AND DEVICES
SAFETY EVALUATION OF A DEVICE
(AMENDED IN ITS ENTIRETY)

NO.: NR-1302-D-101-B

DATE: June 7, 2018

PAGE: 21 OF 29

DEVICE TYPE: Gamma Gauges

EXTERNAL RADIATION LEVELS (Cont.):

QG 100-xxxx with 3.7 GBq (100 mCi) of Co-60

Distance	Maximum Radiation Level			
	From Spherical Housing		From Flange (shutter closed)	
(cm)	µSv/hr	mrem/hr	µSv/hr	mrem/hr
5	376	37.6	212	21.2
30	56	5.6	42.9	4.3
100	9.7	0.97	9.7	0.97

QG 100-xxxx with 111 GBq (3000 mCi) of Cs-137

Distance	Maximum Radiation Level			
	From Spherical Housing		From Flange (shutter closed)	
(cm)	µSv/hr	mrem/hr	µSv/hr	mrem/hr
5	198	19.8	703	70.3
30	30	3.0	143	14.3
100	4.1	0.41	30	3.0

QG 2000-xxxxxxx with 74 GBq (2000 mCi) of Co-60

Distance	Maximum Radiation Level			
	From Spherical Housing		From Flange (shutter closed)	
(cm)	µSv/hr	mrem/hr	µSv/hr	mrem/hr
5	172	17.2	749	74.9
30	36	3.6	156	15.6
100	6.5	0.65	26	2.6

The following dose rates for the FQG series gauges were reported by the manufacturer. The dose rates were obtained from measurements taken in front of the flange **or emission channel** for the FQG series. The data depicts the radiation levels when the shutter is in the closed position. The highest reading is taken from the highest value around the spherical housing.

REGISTRY OF RADIOACTIVE SEALED SOURCES AND DEVICES
SAFETY EVALUATION OF A DEVICE
(AMENDED IN ITS ENTIRETY)

NO.: NR-1302-D-101-B

DATE: June 7, 2018

PAGE: 22 OF 29

DEVICE TYPE: Gamma Gauges

EXTERNAL RADIATION LEVELS (Cont.):

For the FQG66 series the dose rates were measured using a maximum activity of 37 GBq of Cs-137 and 7.4 GBq of Co-60, the radiation profiles were then calculated for maximum activities of 740 GBq of Cs-137 and 185 GBq of Co-60.

			Maximum Radiation Level (µSv/h)		
Model	Isotope	Activity	Distance (cm)	From Spherical Housing	From Flange or Emission Channel (Shutter Closed)
FQG61	Co-60	0.74 GBq	5	324 [518]	218 [348]
			30	50 [80]	51 [81]
			100	7 [12]	9 [14]
	Cs-137	22.2 GBq	5	162 [259]	170 [272]
			30	32 [51]	38 [61]
			100	6 [9]	7 [11]
FQG62	Co-60	3.7 GBq	5	252 [4,3]	236 [378]
			30	43 [69]	53 [85]
			100	7 [11]	10 [16]
	Cs-137	111 GBq	5	63 [100]	577 [924]
			30	11 [18]	144 [231]
			100	2 [4]	21 [33]
FQG66	Co-60	185 GBq	5	461 [669]	1479 [2145]
			30	117 [170]	321 [466]
			100	29.2 [42]	52 [75]
	Cs-137	370 GBq	5	18.2 [26.4]	152 [220]
			30	8.4 [12.2]	33 [47.9]
			100	2.3 [3.3]	5.3 [7.7]

REGISTRY OF RADIOACTIVE SEALED SOURCES AND DEVICES
SAFETY EVALUATION OF A DEVICE
(AMENDED IN ITS ENTIRETY)

NO.: NR-1302-D-101-B

DATE: June 7, 2018

PAGE: 23 OF 29

DEVICE TYPE: Gamma Gauges

EXTERNAL RADIATION LEVELS (Cont.):

Note: Radiation Profile Tables for FQG61 and FQG62 Series Models Values in [brackets]: includes 25% source activity variation above label value, 25% measurement inaccuracy, 10% safety margin. **Radiation Profile Tables for FQG66 Series Models Values in [brackets]: include 25% source tolerance and 20% measurement inaccuracy.**

QUALITY ASSURANCE AND CONTROL:

The manufacturer maintains a certified Quality Management System according to ISO 9001:2000 covering the design, manufacturing, testing and servicing of Endress + Hauser gauges.

The U.S. distributor maintains a certified Quality Management System according to ISO 9001:2000 covering the distribution, testing and servicing of Endress + Hauser nuclear measurement systems.

REGISTRY OF RADIOACTIVE SEALED SOURCES AND DEVICES
SAFETY EVALUATION OF A DEVICE
(AMENDED IN ITS ENTIRETY)

NO.: NR-1302-D-101-B

DATE: June 7, 2018

PAGE: 24 OF 29

DEVICE TYPE: Gamma Gauges

QUALITY ASSURANCE AND CONTROL (Cont.):

Prior to shipment to a customer, the distributor will perform the following quality control procedures in accordance with the ISO Quality Management Program:

- Visual inspection of the device
- Check for correct labeling
- Check for correct operation of safety features
- Check for radiation profiles of the device
- Check for associated operation manual
- Source leak test to less than 185 Bq (0.005 μ Ci) or inspection of the source certificates provided by the source manufacturer for the applied sources
- Furnish a copy of the General License information or ensure a valid Specific License

As an alternate means of loading the sealed sources, Endress + Hauser may also have Eckert & Ziegler located in California load the sealed sources into the source holders before delivery to the end user. Eckert & Ziegler, prior to the shipment of the Endress + Hauser devices to the end user, will perform a wipe test of the Endress + Hauser devices. Endress + Hauser will audit Eckert & Ziegler with an onsite check and annual review. Eckert & Ziegler will not make modifications to the devices.

LIMITATIONS AND/OR OTHER CONSIDERATIONS OF USE:

- The QG 020, QG 100, FQG61 and FQG62 Series, when distributed as generally licensed devices, are only authorized to contain below 81 millicuries of cobalt-60 or 270 millicuries of cesium-137.
- Cesium-137 is not authorized for use in the QG 2000 Series.
- The QG 2000 Series is only authorized to be distributed as a specifically licensed device.

REGISTRY OF RADIOACTIVE SEALED SOURCES AND DEVICES
SAFETY EVALUATION OF A DEVICE
(AMENDED IN ITS ENTIRETY)

NO.: NR-1302-D-101-B

DATE: June 7, 2018

PAGE: 25 OF 29

DEVICE TYPE: Gamma Gauges

LIMITATIONS AND/OR OTHER CONSIDERATIONS OF USE (Cont.):

- The supply pressure of the pneumatic actuated version shall not exceed 6 bar (87 psi). **Only the FQG66 series is authorized for 7 bar (101 psi)**
- The QG Series and FQG Series gauges are not authorized to be mounted at a height greater than 27 feet.
- Devices intended for distribution to persons specifically licensed by the NRC or an Agreement State shall be labeled in accordance with 10 CFR Part 20.
- Devices intended for distribution to persons generally licensed pursuant to 10 CFR Part 31 shall be labeled in accordance with 10 CFR Part 32.51.
- Devices intended for use under a general license shall be installed and initially tested for external radiation levels, required labels and documentation, and leakage-contamination of radioactive material by Endress + Hauser or other persons specifically licensed by the NRC or an Agreement State to perform such activities.
- The general licensee is allowed to perform initial installation.
- **The FQG66 Series is only authorized to be distributed as a specifically licensed device. Only the versions designated as "K" and "B" are authorized for distribution in the U.S.**
- **The FQG66 Series shall only be installed with the cover in the horizontal position.**
- Handling, storage, use, transfer and disposal: for devices used under specific license will be determined by the

REGISTRY OF RADIOACTIVE SEALED SOURCES AND DEVICES
SAFETY EVALUATION OF A DEVICE
(AMENDED IN ITS ENTIRETY)

NO.: NR-1302-D-101-B

DATE: June 7, 2018

PAGE: 26 OF 29

DEVICE TYPE: Gamma Gauges

LIMITATIONS AND/OR OTHER CONSIDERATIONS OF USE (Cont.):

licensing authority. For devices used under a general license are covered by the requirements for 10 CFR 31.5 or the Agreement State equivalent.

- These devices shall be serviced only by Endress + Hauser or persons specifically licensed to do so by the NRC or an Agreement State, with the exception that the user may collect wipe test samples.
- Previously these devices were leak tested at intervals not to exceed 6 months. These devices shall be leak tested at intervals not to exceed 36 months using techniques capable of detecting 0.005 microcurie (185 Bq) of removable contamination, as of December 31, 2010.
- The registration sheet and the information contained within the references shall not be changed without the written consent of the NRC.
- REVIEWER'S NOTE: The QG 020 and QG 100 Series Gauges were discontinued as of December 31, 2009. **The QG 2000 Series was discontinued with the issuance of the amendment dated June 7, 2018.**

SAFETY ANALYSIS SUMMARY:

Endress + Hauser has submitted sufficient information to provide reasonable assurance that:

- The QG Series and FQG Series devices can be safely operated by persons not having training in radiological protection. **The QG 2000 and FQG66 may only be used under a specific license.**

REGISTRY OF RADIOACTIVE SEALED SOURCES AND DEVICES
SAFETY EVALUATION OF A DEVICE
(AMENDED IN ITS ENTIRETY)

NO.: NR-1302-D-101-B

DATE: June 7, 2018

PAGE: 27 OF 29

DEVICE TYPE: Gamma Gauges

SAFETY ANALYSIS SUMMARY (Cont.):

- Under ordinary conditions of handling, storage, and use of the QG Series and FQG Series devices, the byproduct material contained in the devices will not be released or inadvertently removed from the source housing, and it is unlikely that any person will receive in any period of one year a dose in excess of 10 percent of the limits specified in Section 20.1201(a), 10 CFR Part 20. During typical use, the QG Series and FQG Series devices are installed in a process line and are not easily accessible while the QG Series and FQG Series devices are in operation.
- Under accident conditions associated with handling, storage and use, it is unlikely that any person would receive an external radiation dose or dose commitment in excess of the dose to the appropriate organ as specified in the following chart:

PART OF BODY	rem	Sv
Whole body; head and trunk; active blood-forming organs; gonads; or lens of eye	15	0.15
Hands and forearms; feet and ankles; localized areas of skin averaged over areas no larger than 1 square centimeter	200	2.00
Other organs	50	0.50

Based on this information and the test data referenced below, we conclude that the QG Series and FQG Series devices are acceptable for licensing purposes as specified in this certificate.

Furthermore, we conclude that the QG Series and FQG Series gamma gauges would be expected to maintain their integrity for normal conditions of use and accident conditions, which might occur during uses specified in this certificate.

REGISTRY OF RADIOACTIVE SEALED SOURCES AND DEVICES
SAFETY EVALUATION OF A DEVICE
(AMENDED IN ITS ENTIRETY)

NO.: NR-1302-D-101-B

DATE: June 7, 2018

PAGE: 28 OF 29

DEVICE TYPE: Gamma Gauges

REFERENCES:

The following supporting documents for the Model QG and Model FQG Series gauges are hereby incorporated by reference and are made a part of this registry document.

- Endress + Hauser application dated November 14, 2007 with enclosures thereto.
- Endress + Hauser letters dated April 28, 2008 and May 29, 2008 with enclosures thereto.
- Endress + Hauser emails dated June 2, 2008, July 29, 2008 (2), August 15, 2008 and August 18, 2008 with enclosures thereto.
- Endress + Hauser letter dated August 18, 2009 with enclosures thereto.
- Endress + Hauser emails dated August 20, 2009, August 24, 2009, September 4, 2009, September 28, 2009, December 7, 2009, December 11, 2009, December 14, 2009, December 16, 2009, December 23, 2009, January 19, 2010, January 20, 2010, and January 25, 2010 with enclosures thereto.
- Endress + Hauser letters dated May 27, 2010 and July 7, 2010.

REGISTRY OF RADIOACTIVE SEALED SOURCES AND DEVICES
SAFETY EVALUATION OF A DEVICE
(AMENDED IN ITS ENTIRETY)

NO.: NR-1302-D-101-B

DATE: June 7, 2018

PAGE: 29 OF 29

DEVICE TYPE: Gamma Gauges

REFERENCES (Cont.):

- Endress + Hauser letter dated August 12, 2010, with enclosures thereto and emails dated September 13, 2010 and September 14, 2010.
- Endress + Hauser e-mails dated June 13, 2014, August 21, 2014, and September 3, 2014, with enclosures thereto.
- **Endress + Hauser letters dated July 26, 2017 (Pkg: ML17220A220), January 8, 2018 (ML18022A033), March 29, 2018 (ML18092A047), May 11, 2018 (ML18135A198), May 15, 2018 (ML18135A202), and email dated April 12, 2018 (ML18158A112) with enclosures thereto.**

Issuing Agency:

U.S. Nuclear Regulatory Commission

Date: June 7, 2018

Reviewer: /RA/
Tomas Herrera

Date: June 7, 2018

Concurrence: /RA/
Lymari Sepulveda

REGISTRY OF RADIOACTIVE SEALED SOURCES AND DEVICES
SAFETY EVALUATION OF DEVICE
(AMENDED IN ITS ENTIRETY)

NO.: NR-1302-D-101-B

DATE: June 7, 2018

ATTACHMENT: 1 OF 15



QG 020 and QG 100 Series (Standard Version)

QG 020 Series

Height - 280 mm (11.02 in)

Width - 220 mm (8.66 in)

Weight - 40 kg (88 lb)

QG 100 Series

Height - 360 mm (14.7 in)

Width - 220 mm (8.66 in)

Weight - 87 kg (192 lb)

REGISTRY OF RADIOACTIVE SEALED SOURCES AND DEVICES
SAFETY EVALUATION OF DEVICE
(AMENDED IN ITS ENTIRETY)

NO.: NR-1302-D-101-B

DATE: June 7, 2018

ATTACHMENT: 2 OF 15



QG 020 and QG 100 Series (Version with Pneumatic Actuator)

QG 020 Series

Height - 385 mm (15.16 in)
Width - 220 mm (8.66 in)
Weight - 43 kg (94.8 lb)

QG 100 Series

Height - 465 mm (18.31 in)
Width - 220 mm (8.66 in)
Weight - 90 kg (198.4 lb)

REGISTRY OF RADIOACTIVE SEALED SOURCES AND DEVICES
 SAFETY EVALUATION OF DEVICE
 (AMENDED IN ITS ENTIRETY)

NO.: NR-1302-D-101-B

DATE: June 7, 2018

ATTACHMENT: 3 OF 15

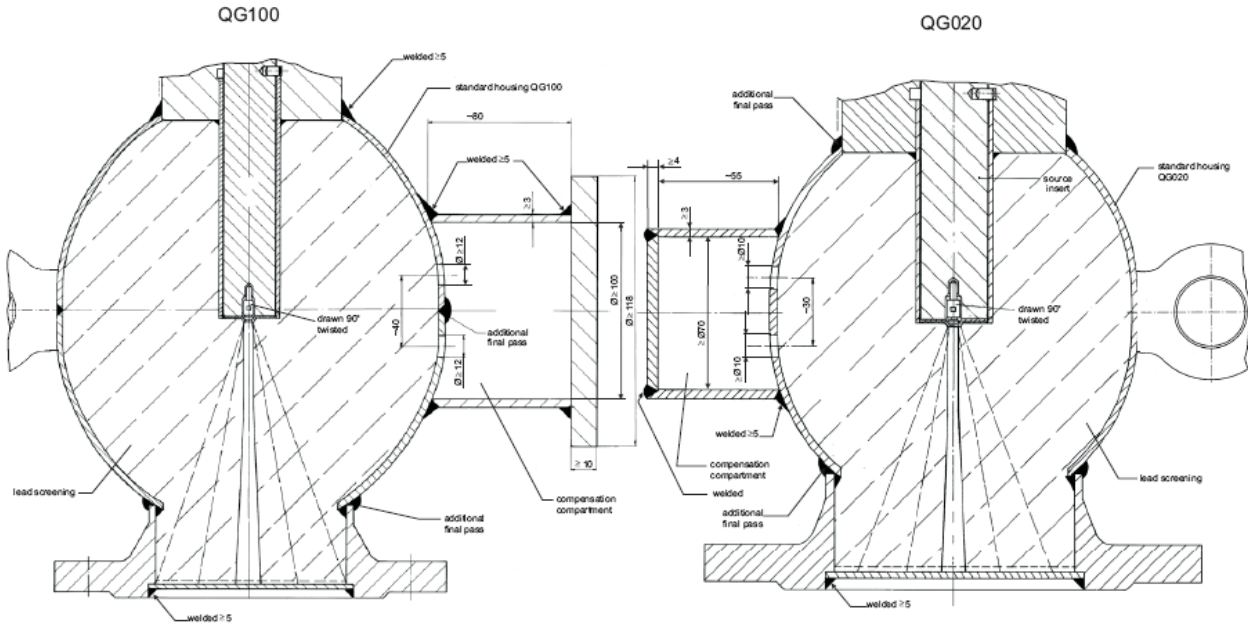

QG 020 and QG 100 Series (Fireproof Version)

QG 100 Series

Height - 360 mm (14.17 in)
 Width - 220 mm (8.66 in)
 Weight - 89 kg (196.5 lb)

QG 020 Series

Height - 280 mm (11.02 in)
 Width - 220 mm (8.66 in)
 Weight - 41 kg (90.5 lb)

REGISTRY OF RADIOACTIVE SEALED SOURCES AND DEVICES
SAFETY EVALUATION OF DEVICE
(AMENDED IN ITS ENTIRETY)

NO.: NR-1302-D-101-B

DATE: June 7, 2018

ATTACHMENT: 4 OF 15

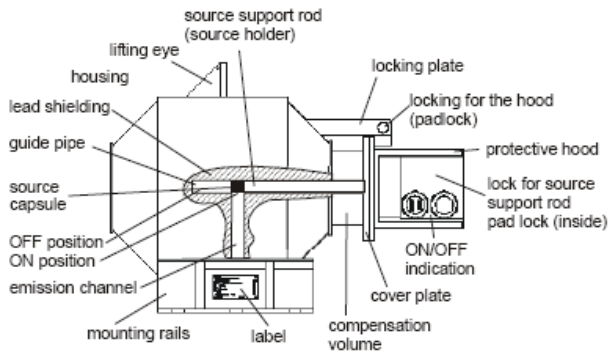

Fig. 1 (standard model)

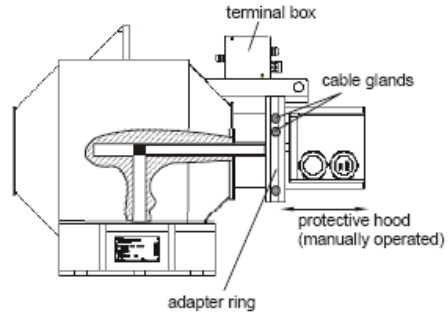

Fig. 2 (model with initiators)



QG 2000 Series
(standard model)

Height - 320 mm (12.6 in)
Width - 635 mm (25 in)
Weight - 350 kg (772 lb)

QG 2000 Series
(model with initiators)

Height - 320 mm (12.6 in)
Width - 635 mm (25 in)
Weight - 351 kg (774 lb)

REGISTRY OF RADIOACTIVE SEALED SOURCES AND DEVICES
SAFETY EVALUATION OF DEVICE
(AMENDED IN ITS ENTIRETY)

NO.: NR-1302-D-101-B

DATE: June 7, 2018

ATTACHMENT: 6 OF 15



FQG61 Series

FQG62 Series

(US Design Version)

Height - 287 mm (11.3 in)

Height - 368 mm (14.5 in)

Width - 220 mm (8.66 in)

Width - 220 mm (8.66 in)

Weight - 40 kg (88.2 lb)

Weight - 87 kg (191.8 lb)

REGISTRY OF RADIOACTIVE SEALED SOURCES AND DEVICES
SAFETY EVALUATION OF DEVICE
(AMENDED IN ITS ENTIRETY)

NO.: NR-1302-D-101-B

DATE: June 7, 2018

ATTACHMENT: 7 OF 15



FQG61 Series

(Version with Pneumatic Actuator)

Height - 427 mm (16.5 in)

Width - 220 mm (8.66 in)

Weight - 50 kg (110.23 lb)

FQG62 Series

Height - 508 mm (19.69 in)

Width - 220 mm (8.66 in)

Weight - 97 kg (213.85 lb)

REGISTRY OF RADIOACTIVE SEALED SOURCES AND DEVICES
SAFETY EVALUATION OF DEVICE
(AMENDED IN ITS ENTIRETY)

NO.: NR-1302-D-101-B

DATE: June 7, 2018

ATTACHMENT: 8 OF 15



FQG61 Series

(Fireproof Version based on US Design version)

Height - 287 mm (11.3 in)

Width - 220 mm (8.66 in)

Weight - 40.8 kg (89.95 lb)

FQG62 Series

Height - 368 mm (14.5 in)

Width - 220 mm (8.66 in)

Weight - 88.3 kg (194.67 lb)

REGISTRY OF RADIOACTIVE SEALED SOURCES AND DEVICES
SAFETY EVALUATION OF DEVICE
(AMENDED IN ITS ENTIRETY)

NO.: NR-1302-D-101-B

DATE: June 7, 2018

ATTACHMENT: 9 OF 15

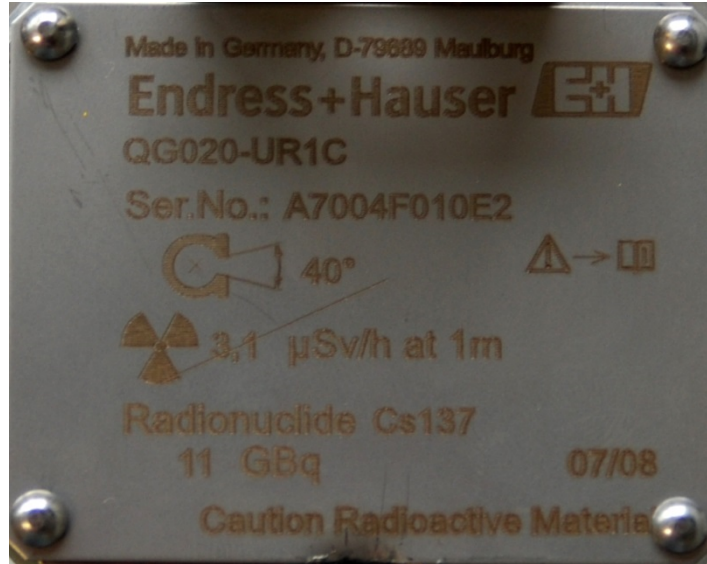

Sample Label for QG 020, QG 100 and QG 2000 Series Gauges

REGISTRY OF RADIOACTIVE SEALED SOURCES AND DEVICES
 SAFETY EVALUATION OF DEVICE
 (AMENDED IN ITS ENTIRETY)

NO.: NR-1302-D-101-B

DATE: June 7, 2018

ATTACHMENT: 10 OF 15

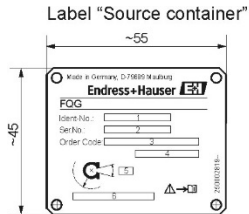

1	Ident number
2	Serial number of container
3	Order code part 1
4	Order code part 2
5	Radiation emission angle
6	...μSv/h at ...m

Material : stainless steel, t = 0,5
laser printed

"ON" , "OFF" labels

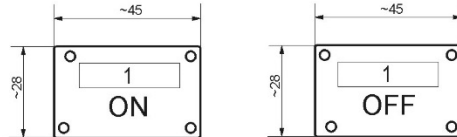

1	Wording acc. to chosen language
---	---------------------------------

Material : stainless steel, t = 0,5
laser printed

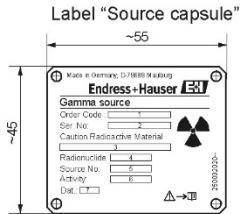

1	Order code (E+H internal)
2	Serial No. (E+H internal)
4	Wording: 'Hochradioaktive Strahlenquelle' depending on activity
5	'Cs137' or 'Co60'
6	Serial No. of source capsule
7	Activity in Mbq or GBq
8	Date (month/year)

Material : stainless steel, t = 0,5
laser printed

Sample Label for FQG61 and FQG62 Series Gauges. **The FQG66 Series will use the same "Source container" and "Source capsule" labels.**
 (US Design)

REGISTRY OF RADIOACTIVE SEALED SOURCES AND DEVICES
SAFETY EVALUATION OF DEVICE
(AMENDED IN ITS ENTIRETY)

NO.: NR-1302-D-101-B

DATE: June 7, 2018

ATTACHMENT: 11 OF 15

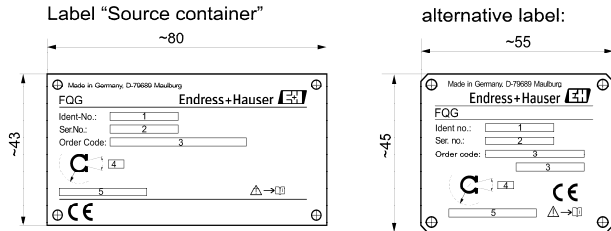

1	Ident number
2	Serial number of container
3	Order code
4	Radiation emission angle
5	...µSv/h at ... m

Material : stainless steel, t = 0,5
laser printed

Additional label "Source capsule"

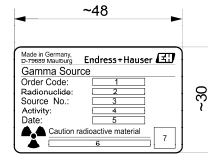

1	Order code (E+H internal)
2	"Cs137" or "Co60"
3	Serial No. of source capsule
4	Activity in Mbq or GBq
5	Date (month/year)
6	Wording: "Hochradioaktive Strahlenquelle" depending on activity
7	Data matrix code (optional)

Material : adhesive metal coated polyester foil
laser printed or thermotransfer print

Label "Source capsule"

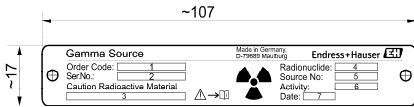

1	Order code (E+H internal)
2	Serial No. (E+H internal)
3	Wording: "Hochradioaktive Strahlenquelle" depending on activity
4	"Cs137" or "Co60"
5	Serial No. of source capsule
6	Activity in Mbq or GBq
7	Date (month/year)

Material : stainless steel, t = 0,5
etched and coated
variable fields laser printed

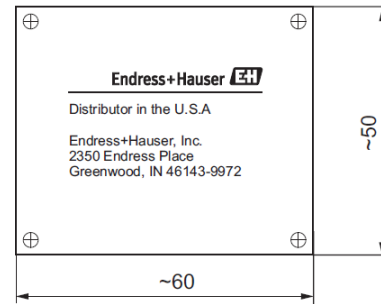

Material: stainless steel, t = 0,5
laser printed

Sample Label for FQG61 and FQG62 Series Gauges. **The FQG66 Series will use the same label identifying the distributor.**

(Pneumatic standard design)

REGISTRY OF RADIOACTIVE SEALED SOURCES AND DEVICES
SAFETY EVALUATION OF DEVICE
(AMENDED IN ITS ENTIRETY)

NO.: NR-1302-D-101-B

DATE: June 7, 2018

ATTACHMENT: 12 OF 15

FQG Model Series	QG Model Series
FQG61/FQG62 - x(B)xxxxxxxx + xxx	QG 020/QG 100 US Design
FQG61/FQG62 - x(K/L)xxxxxxxx + xxx	QG 020/QG 100 Pneumatic standard design
FQG61/FQG62 - xxxxxxxxxxx + x(WE)x	QG 020/QG 100 Fire proof

The "bb" through "nn" are used as place holders for the FQG61/FQG62 Series. They represent License, Version, Source Type, Source Activity, Source Capsule, Container Material, Surface Protection, Emission Angle, Labeling, Certificate, Additional Functions and Optional Markings.

Model	-	Mandatory Designators	-	Additional Designators
FQG61	-	bb c d ee ff g h i k	+	ll mm nn
FQG62	-	bb c d ee ff g h i k	+	ll mm nn

Mandatory Designators:

License	Version (source insert)	Source type	Source Activity	Source Capsule Type	Container (housing material)	Surface protection	Emission angle	Labeling
bb	c	d	ee	ff	g	h	i	k
AD NRC Device Registration General License, USA	B Rotary Bracket + Locking bolt ON + padlock fixation OFF	1 Cesium 137	≤0.74 GBq (Co-60) or ≤22.2 GBq (Cs-137) for FQG61	Any two digit designator representing specified source capsule	A Steel (coated)	Any single letter representing coating	1 5°	A German/ English
AE NRC Device Registration, USA	K Pneumatic Actuator, Non Ex + padlock fixation OFF	2 Cobalt 60	≤3.7 GBq (Co-60) or ≤185 GBq (Cs-137) for FQG62		B Stainless Steel 316L		3 20°	Any single letter representing language combination
	L Pneumatic Actuator, ATEX + padlock fixation OFF + ATEX				C Stainless Steel 304		5 40°	

Additional Designators:

Test, Certificate	Additional Functions	Optional Marking
ll	mm	nn
Any two digit designator representing additional documents	WA Additional clamp (density measurement)	Any two digit designator representing non-safety relevant marking
	WE Fire resistance 800°C/30 min.	
or none	or none	or none

REGISTRY OF RADIOACTIVE SEALED SOURCES AND DEVICES
 SAFETY EVALUATION OF DEVICE
 (AMENDED IN ITS ENTIRETY)

NO.: NR-1302-D-101-B

DATE: June 7, 2018

ATTACHMENT: 13 OF 15

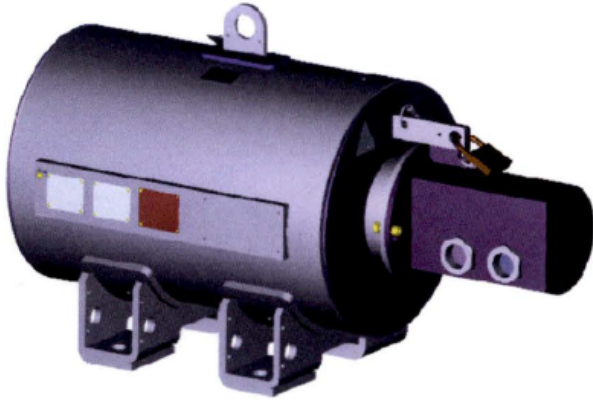

Manually operated type

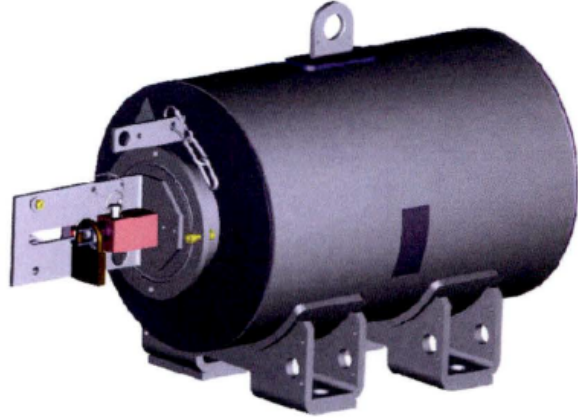

Shutter mechanism (protective hood removed)

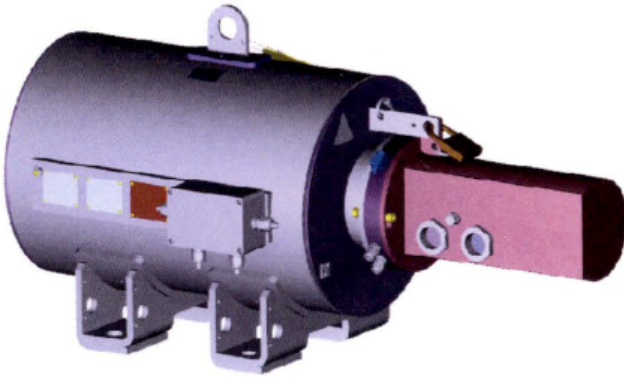

Type with pneumatic actuator

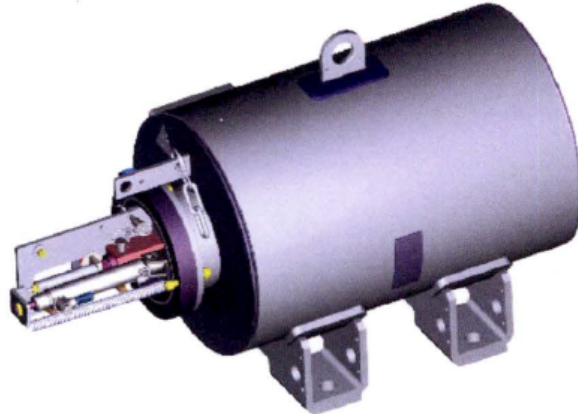

Shutter mechanism (protective hood removed)

Source Container Module	Weight	Dimensions
FQG66 manually operated	Maximum 435 kg (959.2 lb)	L: 780 mm (28.7 in) W: 335 mm (13.2 in) H: 456 mm (18 in) including ring eyelet
FQG66 With pneumatic actuator		L: 833 mm (32.8 in) W: 390 mm (15.4 in) H: 456 mm (18 in) including connection box including ring eyelet

REGISTRY OF RADIOACTIVE SEALED SOURCES AND DEVICES
SAFETY EVALUATION OF DEVICE
(AMENDED IN ITS ENTIRETY)

NO.: NR-1302-D-101-B

DATE: June 7, 2018

ATTACHMENT: 14 OF 15

The "aa" through "nn" are used as place holders for the FQG66 Series. They represent License, Version, Source Type, Source Activity, Source Capsule, Container Material, Surface Protection, Emission Angle, Labeling, Test, Certificate, and Optional Markings.

Model	-	Mandatory Designators	-	Additional Designators
FQG66	-	aa b c ee ff g h i k	+	ll nn

Mandatory Designators:

License	Version	Source type	Source Activity	Source Capsule Type	Container (housing material)	Surface protection	Emission angle	Labeling
aa	b	c	ee	ff	g	h	i	k
AE NRC Device Registration, USA	A Manual operation	1 Cs-137	Any two digit designator representing source activities ≤185 GBq (Co60) or ≤ 740 GBq (Cs137)	Any two digit designator representing specified source capsule with M4 thread or cylindrical capsule	B Stainless Steel 316L	Any single letter representing coating	1 5° Horizontal	A German/ English
	B Manual operation + proximity switch	2 Co-60			Any single letter or number except "B" represent ing stainless steel equal to or better than 316L		2 5° Vertical	
	L Pneumatic actuator + proximity switch						3 20° Horizontal	
							4 20° Vertical	
							5 40° Horizontal	
							6 40° Vertical	

REGISTRY OF RADIOACTIVE SEALED SOURCES AND DEVICES
SAFETY EVALUATION OF DEVICE
(AMENDED IN ITS ENTIRETY)

NO.: NR-1302-D-101-B

DATE: June 7, 2018

ATTACHMENT: 15 OF 15

Additional Designators:

Test, Certificate	Optional Marking
11	nn
Any two digit designator representing additional documents	Any two digit designator representing non- safety relevant marking
or none	or none