

# Safety Instructions

## Micropilot

### FMR60, FMR62, FMR67

4-20 mA HART

Control Drawing IS



Document: XA01615F-B  
Safety instructions for electrical apparatus for explosion-hazardous areas →  3

Document: XA01615F-B  
Temperature tables →  19

Document: XA01615F-B  
Attachment: Nameplate view →  47

---

# Micropilot FMR60, FMR62, FMR67

4-20 mA HART

## Table of contents

Associated documentation . . . . .	4
Manufacturer's certificates . . . . .	4
Manufacturer address . . . . .	4
Extended order code . . . . .	4
Combined type of protection (Approval code, 8A) . . . . .	8
Safety instructions: General . . . . .	8
Safety instructions: Special conditions . . . . .	9
Safety instructions: Installation . . . . .	10
Intrinsic safety . . . . .	10
Class I, Div. 2, Groups A-D . . . . .	11
Process seals . . . . .	12
Temperature tables . . . . .	13
Connection data . . . . .	13

**Associated documentation** This document is an integral part of the following Operating Instructions:

- BA01618F/00 (FMR60)
- BA01619F/00 (FMR62)
- BA01620F/00 (FMR67)

**Manufacturer's certificates** **FM C/US certificate**

Certificate number:

- FM17US0187X
- FM17CA0099X

**Manufacturer address** Endress+Hauser SE+Co. KG  
Hauptstraße 1  
79689 Maulburg, Germany  
Address of the manufacturing plant: See nameplate.

**Extended order code** The extended order code is indicated on the nameplate, which is affixed to the device in such a way that it is clearly visible. Additional information about the nameplate is provided in the associated Operating Instructions.

**Structure of the extended order code**

FMR6x	–	*****	+	A*B*C*D*E*F*G*..
<i>(Device type)</i>		<i>(Basic specifications)</i>		<i>(Optional specifications)</i>

\* = Placeholder

At this position, an option (number or letter) selected from the specification is displayed instead of the placeholders.

*Basic specifications*

The features that are absolutely essential for the device (mandatory features) are specified in the basic specifications. The number of positions depends on the number of features available. The selected option of a feature can consist of several positions.

*Optional specifications*

The optional specifications describe additional features for the device (optional features). The number of positions depends on the number of features available. The features have a 2-digit structure to aid identification (e.g. JA). The first digit (ID) stands for the feature group and consists of a number or a letter (e.g. J = Test, Certificate). The second digit constitutes the value that stands for the feature within the group (e.g. A = 3.1 material (wetted parts), inspection certificate).

More detailed information about the device is provided in the following tables. These tables describe the individual positions and IDs in the extended order code which are relevant to hazardous locations.

**Extended order code: Micropilot**

The following specifications reproduce an extract from the product structure and are used to assign:

- This documentation to the device (using the extended order code on the nameplate).
- The device options cited in the document.

*Device type*

FMR60, FMR62, FMR67

*Basic specifications*

Position 1, 2 (Approval)		
Selected option		Description
FMR6x	FA	FM IS Cl.I Div.1 Gr.A-D
	FB	FM IS Cl.I,II,III Div.1 Gr.A-G, AEx ia, NI Cl.1 Div.2
	8A	FM/CSA IS+XP-IS Cl.I Div.1 Gr.A-D, DIP-IS Cl.II,III Div.1 Gr.E-G
FMR62	FF	FM IS Cl.I Div.1 Gr.A-D, AEx ia, NI Cl.1 Div.2

Position 3 (Power Supply, Output)		
Selected option		Description
FMR6x	A	2-wire, 4-20 mA HART
	B	2-wire, 4-20 mA HART, switch output (PFS)
	C	2-wire, 4-20 mA HART, 4...20 mA

Position 4 (Display, Operation)		
Selected option		Description
FMR6x	A	Without, via communication
	C	SD02, 4-line, push buttons + data backup function
	E	SD03, 4-line, illum., touch control + data backup function
	L	Prepared for display FHX50 + M12 connection
	M	Prepared for display FHX50 + custom connection
	N <sup>1)</sup>	Prepared for display FHX50 + NPT1/2"

1) Only in connection with Position 5 (Housing) = B, C

Position 5 (Housing)		
Selected option		Description
FMR6x	A <sup>1)</sup>	GT19 dual compartment, plastic PBT
	C	GT20 dual compartment, Alu, coated
FMR62 FMR67	B	GT18 dual compartment, 316L

1) Only in connection with Position 1, 2 (Approval) = FA

Position 6 (Electrical Connection)		
Selected option		Description
FMR6x	A <sup>1)</sup>	Gland M20, IP66/68 NEMA4X/6P
	C <sup>2)</sup>	Thread G1/2, IP66/68 NEMA4X/6P
	D	Thread NPT1/2, IP66/68 NEMA4X/6P
	I <sup>1)</sup>	Plug M12, IP66/68 NEMA4X/6P
	M <sup>1)</sup>	Plug 7/8", IP66/68 NEMA4X/6P

- 1) Only in connection with Position 1, 2 (Approval) = FA  
 2) Only in connection with Position 1, 2 (Approval) = FA, FB, FF

Position 7, 8 (Antenna)		
Selected option		Description
FMR60	GA	Drip-off, PTFE DN50
FMR62	GE	Integrated, PEEK, 3/4"
	GF	Integrated, PEEK, 1-1/2"
	GM	PTFE cladded flush mount DN50
	GN	PTFE cladded flush mount DN80
FMR67	GA	Drip-off, PTFE DN50
	GP	PTFE flush mount DN80

Position 9, 10 (Seal)		
Selected option		Description
FMR60	A3	FKM Viton GLT, -40...80°C/-40...176°F
	A4	FKM Viton GLT, -40...130°C/-40...266°F
	C1 <sup>1)</sup>	FFKM Kalrez, -20...150°C/-4...302°F
	B4 <sup>1)</sup>	EPDM, -40...150°C/-40...302°F
FMR62	A5	FKM Viton GLT, -40...150°C/-40...302°F
	A6	FKM Viton GLT, -40...200°C/-40...392°F
	C1	FFKM Kalrez, -20...150°C/-4...302°F
	C2	FFKM Kalrez, -20...200°C/-4...392°F
	F5	PTFE cladded, -40...150°C/-40...302°F
	F6	PTFE cladded, -40...200°C/-40...392°F
FMR67	A3	FKM Viton GLT, -40...80°C/-40...176°F
	A5	FKM Viton GLT, -40...150°C/-40...302°F
	A6	FKM Viton GLT, -40...200°C/-40...392°F

- 1) Only in connection with Position 1, 2 (Approval) = FA, FB, FF

Position 11-13 (Process Connection)		
Selected option		Description
FMR60	GGJ	Thread ISO228 G1-1/2, 316L
	RGJ	Thread ANSI MNPT1-1/2, 316L
	XxG	Flange (different sizes), PP
	Xxj	Flange (different sizes), 316L

Position 11-13 (Process Connection)		
Selected option		Description
FMR62	AxK	Flange (different sizes), PTFE>316/316L
	CxK	Flange (different sizes), PTFE>316L
	GxJ	Thread ISO (different sizes), 316L
	KxK	Flange (different sizes), PTFE>316L
	MxK	Slotted-nut (different sizes), PTFE>316L
	RxJ	Thread ANSI (different sizes), 316L
	TxK	Tri-Clamp (different sizes), PTFE>316L
FMR67	AxJ	Flange (different sizes), 316/316L
	CxJ	Flange (different sizes), 316L
	GGJ	Thread ISO228 G1-1/2, 316L
	KxJ	Flange (different sizes), 316L
	RGJ	Thread ANSI MNPT1-1/2, 316L
	XxA	Align. device (different sizes)
	XxG	Flange (different sizes), PP
	XxJ	Flange (different sizes), 316L

Position 14 (Air Purge Connection)		
Selected option		Description
FMR67	A <sup>1)</sup>	W/o
	1 <sup>2)</sup>	G1/4
	2 <sup>2)</sup>	NPT1/4
	3 <sup>1)</sup>	Adapter G1/4
	4 <sup>1)</sup>	Adapter NPT1/4

- 1) Only in connection with Position 7, 8 (Antenna) = GA  
2) Only in connection with Position 7, 8 (Antenna) = GP

#### Optional specifications

ID Nx (Accessory Mounted)		
Selected option		Description
FMR6x	NA <sup>1)</sup>	Overvoltage protection
	NF <sup>2)</sup>	Bluetooth
FMR60 FMR62	NC	Gas-tight feed through

- 1) Only in connection with Position 1, 2 (Approval) = FA, FB, FF  
2) Only in connection with Position 4 (Display, Operation) = C, E

**Combined type of protection (Approval code, 8A)**

Devices with approval code "8A" are suitable for installation with explosion protection type of Intrinsic Safety or Explosionproof.

- Before initial commissioning, specify the type of protection.
- It is not permitted to change the type of protection after initial commissioning as this can jeopardize the explosion protection.

For aluminum housings:

Void out the explosion protection that is not used on the nameplate.

For stainless steel housings:

Using a striking tool, mark the explosion protection used, or void out the explosion protection that is not used.

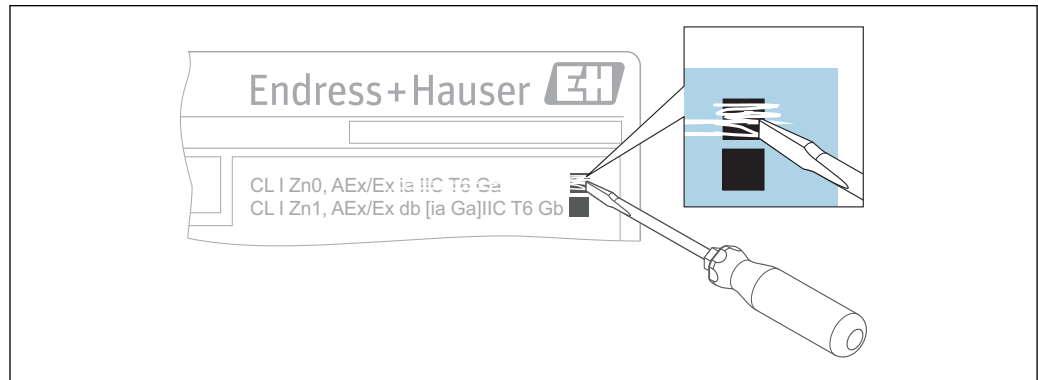

A003253

1

**i** It is critical to observe and follow the correct instructions for installation depending on the type of protection used. Refer to the following table for reference to the correct installation instructions.

Type of protection	Agency approval	Control Drawing no. / Document no.
Intrinsic Safety	CSA	XA01612F
	FM	XA01615F
Explosionproof	CSA	XA01613F
	FM	XA01616F

Class I, Division 2 installation:

References in this manual to Class I, Division 2 installation are not applicable for devices with the combined type of protection. For installation in Class I, Division 2, these devices must be installed per the applicable Division 1 intrinsic safety or explosionproof requirements.

**Safety instructions: General**

- Staff must meet the following conditions for mounting, electrical installation, commissioning and maintenance of the device:
  - Be suitably qualified for their role and the tasks they perform
  - Be trained in explosion protection
  - Be familiar with national regulations
- Install the device according to the manufacturer's instructions and national regulations.
- Do not operate the device outside the specified electrical, thermal and mechanical parameters.
- Only use the device in media to which the wetted materials have sufficient durability.



- Avoid electrostatic charging:
  - Of plastic surfaces (e.g. housing, sensor element, special varnishing, attached additional plates, ..)
  - Of isolated capacities (e.g. isolated metallic plates)
- Modifications to the device can affect the explosion protection and must be carried out by staff authorized to perform such work by Endress+Hauser.
- Refer to the temperature tables for the relationship between the permitted ambient temperature for the sensor and/or transmitter, depending on the range of application and the temperature class.

#### Safety instructions: Special conditions

Permitted ambient temperature range at the electronics housing:  
 $-40\text{ °C} \leq T_a \leq +80\text{ °C}$

- Observe the information in the temperature tables.
- Use supply wires suitable for 20 K above the ambient temperature.
- In the event of additional or alternative special varnishing on the housing or other metal parts:
  - Observe the danger of electrostatic charging and discharge.
  - Do not rub surfaces with a dry cloth.

*Device type FMR67 and Basic specification, Position 11-13 (Process Connection) = XxA*

- Avoid sparks caused by impact and friction.
- Changing the position of the alignment device must be impossible:
  - After the alignment of the antenna via the pivot bracket
  - After tightening of the clamping flange
  - After setting the damping ring (torque 10 to 11 Nm)
- Degree of protection IP67 must be fulfilled.

*Device type FMR67 and Basic specification, Position 14 (Air Purge Connection) = 1, 2*

- For Class I, II, III, Division 1 and for Class I, Zone 0, Zone 1: In the closed state the minimum degree of protection of the installation must be IP67.
- After removing the air purge connection: Lock the opening with a suitable plug.
  - Torque: 6-7 Nm
  - For Class II and III: thread engagement > 5 turns
- Degree of protection IP67 must be fulfilled.

#### Electrostatic/impact sparks

- In the case of process connections made of polymeric material or with polymeric coatings, avoid electrostatic charging of the plastic surfaces.
- The antennas can be electrostatically charged.

*Basic specification, Position 5 (Housing) = A*

Avoid electrostatic charging of the housing (e.g. friction, cleaning, maintenance, strong medium flow).

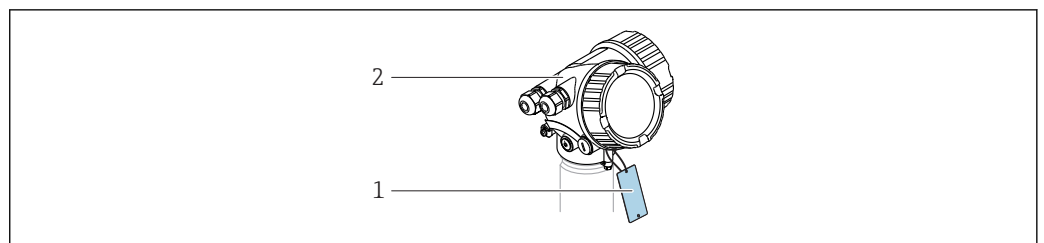

A0032146

2

- 1 Isolated capacitance:  
with one metal plate:  $\leq 3\text{ pF}$  (permitted for Class I, II, III, Division 1, Division 2 and for Class I, Zone 0, Zone 1)
- 2 Housing

*Basic specification, Position 5 (Housing) = C*

Avoid sparks caused by impact and friction.

## Safety instructions: Installation

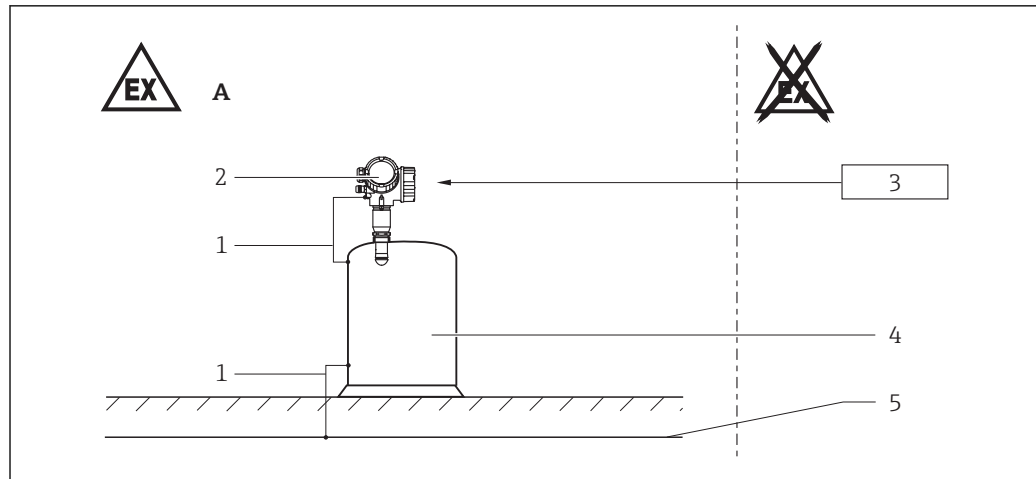

A0031938



- A Class I, Div. 1, Zone 0, Zone 1 or Class I, Div. 2, Groups A, B, C, D;  
Class II, Div. 1, Groups E, F, G;  
Class III
- 1 Potential equalization line  
2 Electronic insert  
3 Certified associated apparatus  
4 Tank; Zone 0, Zone 1  
5 Potential equalization

- After aligning (rotating) the housing, retighten the fixing screw (see Operating Instructions).
- Install the device to exclude any mechanical damage or friction during the application. Pay particular attention to flow conditions and tank fittings.
- Continuous service temperature of the connecting cable:  $-40\text{ °C}$  to  $\geq +85\text{ °C}$ ; in accordance with the range of service temperature taking into account additional influences of the process conditions ( $T_{a,\min}$ ), ( $T_{a,\max} + 20\text{ K}$ ).

Basic specification, Position 4 (Display, Operation) = N

Observe national regulations and standards for conduit systems.

### Bluetooth® module

Optional specification, ID Nx (Accessory Mounted) = NF

- With Bluetooth® module installed: Use of external hardware not allowed (e.g. external display, service interface).
- The intrinsically safe input power circuit of the Bluetooth® module is isolated from ground.

## Intrinsic safety

Intrinsically safe, Class I, Div. 1, Groups A, B, C, D, Class II, Div. 1, Groups E, F, G, Class III  
Class I, Zone 0 or Zone 1, AEx ia IIC/Ex ia IIC

### Entity installation

- Use an intrinsic safety barrier or other associated equipment that is approved for the country in use and satisfies the following conditions:  $U_o (V_{oc}) \leq U_i (V_{max})$ ,  $I_o (I_{sc}) \leq I_i (I_{max})$ ,  $C_o (C_a) \geq C_i + C_{cable}$ ,  $L_o (L_a) \geq L_i + L_{cable}$  and  $P_o \leq P_i$ .
- For transmitter parameters: See "Connection data" section.
- Control room equipment may not use or generate over  $250\text{ V}_{rms}$ .
- Install as per National Electrical Code (NFPA70) or Canadian Electrical Code, Part I (C22.1), as applicable.
- WARNINGS: Potential electrostatic charging hazard: See instructions. Substitution of components may impair suitability for hazardous locations.
- Always follow the installation instructions provided by the intrinsic safety barrier manufacturer when installing this equipment.

- The configuration of the intrinsic safety barrier(s) must be FM-approved.
- When prepared for use with an approved remote display FHX50, remote display is intrinsically safe suitable for Class I, Division 1/Zone 0 locations and connection between transmitter housing and remote display is intrinsically safe field wiring.
- The device can be equipped with the Bluetooth® module: refer to the Operating Instructions and specifications in the "Bluetooth® module" chapter.

For Class II and III

Keep covers tight unless power has been switched off.

### Class I, Div. 2, Groups A-D

The following instructions apply only for *Device type FMR6x, Basic specification, Position 1, 2 (Approval) = FB, FF*

*Device type FMR6x, Basic specification, Position 1, 2 (Approval) = FA and 8A* are not marked for use in Class I, Division 2; however, these devices are suitable for this application when installed using the intrinsic safety instructions for Class I, Division 1.

### Nonincendive Field Wiring (NIFW) installation

- The Nonincendive Field Wiring circuit concept allows interconnection of nonincendive field wiring apparatus with associated nonincendive field wiring apparatus or associated apparatus not specifically examined in combination as a system using any of the wiring methods permitted for unclassified locations, when the following conditions are met:  $V_{max} \geq V_{oc}$  or  $V_t$ ,  $C_a \geq C_i + C_{cable}$ ,  $I_a \geq I_i + I_{cable}$ .
- For transmitter parameters: See "Connection data" section.
- The transmitter provides a current controlled circuit; therefore, the parameter  $I_{max}$  is not required and needs not to be aligned with  $I_{sc}$  and  $I_t$  of the associated nonincendive field wiring apparatus or associated apparatus.
- Control room equipment may not use or generate over 250 V<sub>rms</sub>.
- Install as per National Electrical Code (NFPA70) or Canadian Electrical Code, Part I (C22.1), as applicable.
- WARNINGS: Potential electrostatic charging hazard: See instructions.  
Substitution of components may impair suitability for hazardous locations. For Div. 2, do not disconnect equipment unless power has been switched off or area is known to be non-hazardous.
- Always follow the installation drawing provided by the associated apparatus manufacturer.  
The configuration of the associated apparatus must be approved for the country in use.

*Device type FMR6x, Basic specification, Position 3 (Power Supply; Output) = A*

- Probe is suitable for installation in Class I, Division 2 only when using this wiring method. If probe is installed in a location classified as Class I, II, III, Division 1/Zone 0, supply must be connected to associated apparatus per the intrinsic safety instructions above.
- When prepared for use with an approved remote display FHX50, remote display is suitable for Class I, Division 2 locations only and connection between transmitter housing and remote display is nonincendive field wiring. If associated apparatus is used per the intrinsic safety instructions above, remote display is suitable for Class I, Division 1/Zone 0 locations and connection between transmitter housing and remote display is intrinsically safe wiring.

*Device type FMR6x, Basic specification, Position 3 (Power Supply; Output) = B, C*

- Probe is intrinsically safe, AEx ia/Ex ia, and suitable for installation in Class I, II, III, Division 1 or Class I, Zone 0/1.
- When prepared for use with an approved remote display FHX50, remote display is intrinsically safe suitable for Class I, Division 1/Zone 0 locations and connection between transmitter housing and remote display is intrinsically safe field wiring.

### Standard Wiring installation (only for NPT conduit entries)

- Install as per National Electrical Code (NFPA70) or Canadian Electrical Code, Part I (C22.1), as applicable.
- Using wiring methods appropriate for the location.
- Associated apparatus not required.
- For the maximum supply voltage: See "Connection data" section.
- WARNINGS: Potential electrostatic charging hazard: See instructions.  
Substitution of components may impair suitability for hazardous locations. For Div. 2, do not disconnect equipment unless power has been switched off or area is known to be non-hazardous.

*Device type FMR6x, Basic specification, Position 3 (Power Supply; Output) = A*

- Probe is suitable for installation in Class I, Division 2 only when using this wiring method. If probe is installed in a location classified as Class I, II, III, Division 1/Zone 0, supply must be connected to associated apparatus per the intrinsic safety instructions above.
- When prepared for use with an approved remote display FHX50, remote display is suitable for Class I, Division 2 locations only and connection between transmitter housing and remote display is nonincendive field wiring. If associated apparatus is used per the intrinsic safety instructions above, remote display is suitable for Class I, Division 1/Zone 0 locations and connection between transmitter housing and remote display is intrinsically safe wiring.

*Device type FMR6x, Basic specification, Position 3 (Power Supply; Output) = B, C*

- Probe is intrinsically safe, AEx ia/Ex ia, and suitable for installation in Class I, II, III, Division 1 or Class I, Zone 0/1.
- When prepared for use with an approved remote display FHX50, remote display is intrinsically safe suitable for Class I, Division 1/Zone 0 locations and connection between transmitter housing and remote display is intrinsically safe field wiring.

## Process seals

The following device types are Single Seal devices per ANSI/ISA 12.27.01 and do not require the use of an external process seal.

Device type	Basic specification, Position 7, 8 (Antenna)	Basic specification, Position 9, 10 (Seal)	Basic specification, Position 11-13 (Process Connection)	Optional specification, ID Nx (Accessory Mounted)	MWP <sup>1)</sup>
FMR60-FA FMR60-FB	xx	xx	xxx	NC	3 bar
FMR62-FA FMR62-FB FMR62-FF	GE, GF	A5, C1	xxx	NC	16 bar <sup>2)</sup>
	GE, GF	A6, C2	xxx	–	16 bar <sup>2)</sup>
	GM, GN	F5	xxx	NC	16 bar <sup>3)</sup>
	GM, GN	F6	xxx	–	16 bar <sup>3)</sup>
FMR67-FA FMR67-FB	GP	A6	xxx	–	16 bar

- 1) Maximum Working Pressure for the Single Seal rating.
- 2) Up to 20 bar (no Single Seal rating). In this case an external process seal is to be used where required by the CEC, Part I or NEC (as applicable).
- 3) Up to 25 bar (no Single Seal rating). In this case an external process seal is to be used where required by the CEC, Part I or NEC (as applicable).

The following device types are Dual Seal devices per ANSI/ISA 12.27.01 and do not require the use of an external secondary process seal.

Device type	Basic specification, Position 7, 8 (Antenna)	Basic specification, Position 9, 10 (Seal)	Basic specification, Position 11-13 (Process Connection)	MWP <sup>1)</sup>	Method of annunciation
FMR60-8A	xx	xx	xxx	3 bar	Process fluid leakage through vent located in electronics compartment. When using the remote display FHX50: Leakage may also occur from the vent located in the remote display housing.
FMR62-8A	GE	xx	xxx	20 bar	
	GF	xx	xxx	20 bar	
	GM	xx	xxx	25 bar	
FMR67-8A	GN	xx	xxx	25 bar	No maintenance of annunciator necessary.
	GA	A3	Axx, Cxx, Kxx, Xxx	3 bar	
	GA	A3	GGJ, RGJ	16 bar	
	GP	xx	xxx	16 bar	

1) Maximum Working Pressure for the Dual Seal rating to be effective and may be a value less than the MWP for the device.

 Verify the chemical compatibility of the process seal specified on the nameplate in first position with the process fluid (see field "Mat." on the nameplate).

*Basic specification, Position 4 (Display, Operation) = L M, N and a cable provided by customer, gland M16 or thread NPT1/2*

To prevent possible leakage of process fluids in an area classified as non-hazardous, the FHX50 must be installed in the hazardous location when used with a device with a Dual Seal rating.

**Temperature tables**

→  20

**Connection data**

*Optional specification, ID Nx (Accessory Mounted) = NA*  
*(Overvoltage protection Type OVP10 and Type OVP20)*

When using the internal overvoltage protection: No changes to the connection values.

*Optional specification, ID Nx (Accessory Mounted) = NF*

When using the Bluetooth® module: No changes to the connection values.

*Basic specification, Position 1, 2 (Approval) = FA*

*Basic specification, Position 3 (Power Supply, Output) = A*

IS, Class I, Div. 1; Class I, Zone 0, AEx ia/Ex ia

Terminal 1 (+), 2 (-)
Power supply: $U_i = 30\text{ V}$ $I_i = 300\text{ mA}$ $P_i = 1\text{ W}$ effective inner inductance $L_i = 0$ effective inner capacitance $C_i = 12\text{ nF}$

*Basic specification, Position 3 (Power Supply, Output) = B*  
IS, Class I, Div. 1; Class I, Zone 0, AEx ia/Ex ia

Terminal 1 (+), 2 (-)	Terminal 3 (+), 4 (-)
Power supply: $U_i = 30\text{ V}$ $I_i = 300\text{ mA}$ $P_i = 1\text{ W}$ effective inner inductance $L_i = 0$ effective inner capacitance $C_i = 5\text{ nF}$	Switch output (PFS): $U_i = 30\text{ V}$ $I_i = 300\text{ mA}$ $P_i = 1\text{ W}$ effective inner inductance $L_i = 0$ effective inner capacitance $C_i = 6\text{ nF}$

*Basic specification, Position 3 (Power Supply, Output) = C*  
IS, Class I, Div. 1; Class I, Zone 0, AEx ia/Ex ia

Terminal 1 (+), 2 (-)	Terminal 3 (+), 4 (-)
Power supply: $U_i = 30\text{ V}^{1)}$ $I_i = 300\text{ mA}$ $P_i = 1\text{ W}$ effective inner inductance $L_i = 0$ effective inner capacitance $C_i = 30\text{ nF}$	Output 4 to 20 mA: $U_i = 30\text{ V}^{1)}$ $I_i = 300\text{ mA}$ $P_i = 1\text{ W}$ effective inner inductance $L_i = 0$ effective inner capacitance $C_i = 30\text{ nF}$

1) For functional reasons, input may be limited to a reduced supply voltage of  $28\text{ V}_{\text{DC}}$

*Basic specification, Position 1, 2 (Approval) = FB, FF*

*Basic specification, Position 3 (Power Supply, Output) = A*  
IS, Class I, Div. 1; Class I, Zone 0, AEx ia/Ex ia

Terminal 1 (+), 2 (-)
Power supply: $U_i = 30\text{ V}$ $I_i = 300\text{ mA}$ $P_i = 1\text{ W}$ effective inner inductance $L_i = 0$ effective inner capacitance $C_i = 12\text{ nF}$

NIFW: Class I, Div. 2

Terminal 1 (+), 2 (-)
Power supply: $U_i = 30\text{ V}$ $I_i = \text{transmitter is a current controlled device}$ effective inner inductance $L_i = 0$ effective inner capacitance $C_i = 12\text{ nF}$

Class I, Div. 2

Terminal 1 (+), 2 (-)
Power supply: Input voltage = $30\text{ V}$ Input current = $22.5\text{ mA}$

Basic specification, Position 3 (Power Supply, Output) = B  
 IS, Class I, II, III, Div. 1; Class I, Zone 0, AEx ia/Ex ia

Terminal 1 (+), 2 (-)	Terminal 3 (+), 4 (-)
Power supply: $U_i = 30\text{ V}$ $I_i = 300\text{ mA}$ $P_i = 1\text{ W}$ effective inner inductance $L_i = 0$ effective inner capacitance $C_i = 5\text{ nF}$	Switch output (PFS): $U_i = 30\text{ V}$ $I_i = 300\text{ mA}$ $P_i = 1\text{ W}$ effective inner inductance $L_i = 0$ effective inner capacitance $C_i = 6\text{ nF}$

NIFW: Class I, Div. 2

Terminal 1 (+), 2 (-)	Terminal 3 (+), 4 (-)
Power supply: $U_i = 30\text{ V}$ $I_i = \text{transmitter is a current controlled device}$ effective inner inductance $L_i = 0$ effective inner capacitance $C_i = 5\text{ nF}$	Switch output (PFS): $U_i = 30\text{ V}$ $I_i = \text{transmitter is a current controlled device}$ effective inner inductance $L_i = 0$ effective inner capacitance $C_i = 6\text{ nF}$

Class I, Div. 2

Terminal 1 (+), 2 (-)	Terminal 3 (+), 4 (-)
Power supply: Input voltage = 30 V Input current = 22 mA	Switch output (PFS): Input voltage = 30 V $P_i = 1\text{ W}$

The power consumption of I/O modules with passive PFS output can be limited for certain applications.

- Recommended: Power consumption = 1 W. This is obtained for a supply voltage at the terminals of 27 V<sub>DC</sub>.
- For higher supply voltages ( $U_{\max}$ ): Insert a serial resistance ( $R_V$ ) in order to limit the power consumption, see table below.

**Table for the PFS serial resistance ( $R_V$ ):**

Power consumption	1.0 W
Total power consumption	1.88 W
Internal resistance $R_i$	760 $\Omega$

$U_{\max}$ [V]	$R_V$ min
30	67 $\Omega$
29	39 $\Omega$
28	12 $\Omega$
27	0 $\Omega$

 For values associated with a higher or lower internal power consumption please contact Endress+Hauser.

Basic specification, Position 3 (Power Supply, Output) = C  
IS, Class I, II, III, Div. 1; Class I, Zone 0, AEx ia/Ex ia

Terminal 1 (+), 2 (-)	Terminal 3 (+), 4 (-)
Power supply: $U_i = 30\text{ V}^{1)}$ $I_i = 300\text{ mA}$ $P_i = 1\text{ W}$ effective inner inductance $L_i = 0$ effective inner capacitance $C_i = 30\text{ nF}$	Output 4 to 20 mA: $U_i = 30\text{ V}^{1)}$ $I_i = 300\text{ mA}$ $P_i = 1\text{ W}$ effective inner inductance $L_i = 0$ effective inner capacitance $C_i = 30\text{ nF}$

1) For functional reasons, input may be limited to a reduced supply voltage of  $28\text{ V}_{\text{DC}}$

NIFW: Class I, Div. 2

Terminal 1 (+), 2 (-)	Terminal 3 (+), 4 (-)
Power supply: $U_i = 30\text{ V}^{1)}$ $I_i = \text{transmitter is a current controlled device}$ effective inner inductance $L_i = 0$ effective inner capacitance $C_i = 30\text{ nF}$	Output 4 to 20 mA: $U_i = 30\text{ V}^{1)}$ $I_i = \text{transmitter is a current controlled device}$ effective inner inductance $L_i = 0$ effective inner capacitance $C_i = 30\text{ nF}$

1) For functional reasons, input may be limited to a reduced supply voltage of  $28\text{ V}_{\text{DC}}$

Class I, Div. 2

Terminal 1 (+), 2 (-)	Terminal 3 (+), 4 (-)
Power supply: Input voltage = $30\text{ V}^{1)}$ Input current = $22\text{ mA}$	Output 4 to 20 mA: Input voltage = $30\text{ V}^{1)}$ Input current = $22\text{ mA}$

1) For functional reasons, input may be limited to a reduced supply voltage of  $28\text{ V}_{\text{DC}}$



Div. 2

Probe is suitable for installation in Class I, Division 2 only. If probe is installed in a location classified as Class I, Division 1/Zone 0, Terminal 1 (+), 2 (-) must be connected to associated apparatus with intrinsically safe outputs.



*Basic specification, Position 1, 2 (Approval) = 8A*

*Basic specification, Position 3 (Power Supply, Output) = A*  
IS, Class I, II, III, Div. 1; Class I, Zone 0, AEx ia/Ex ia

<b>Terminal 1 (+), 2 (-)</b>
Power supply: $U_i = 30\text{ V}$ $I_i = 300\text{ mA}$ $P_i = 1\text{ W}$ effective inner inductance $L_i = 0$ effective inner capacitance $C_i = 5\text{ nF}$

*Basic specification, Position 3 (Power Supply, Output) = B*

IS, Class I, II, III, Div. 1; Class I, Zone 0, AEx ia/Ex ia

<b>Terminal 1 (+), 2 (-)</b>	<b>Terminal 3 (+), 4 (-)</b>
Power supply: $U_i = 30\text{ V}$ $I_i = 300\text{ mA}$ $P_i = 1\text{ W}$ effective inner inductance $L_i = 0$ effective inner capacitance $C_i = 5\text{ nF}$	Switch output (PFS): $U_i = 30\text{ V}$ $I_i = 300\text{ mA}$ $P_i = 1\text{ W}$ effective inner inductance $L_i = 0$ effective inner capacitance $C_i = 6\text{ nF}$

*Basic specification, Position 3 (Power Supply, Output) = C*

IS, Class I, II, III, Div. 1; Class I, Zone 0, AEx ia/Ex ia

<b>Terminal 1 (+), 2 (-)</b>	<b>Terminal 3 (+), 4 (-)</b>
Power supply: $U_i = 30\text{ V}^{1)}$ $I_i = 300\text{ mA}$ $P_i = 1\text{ W}$ effective inner inductance $L_i = 0$ effective inner capacitance $C_i = 30\text{ nF}$	Output 4 to 20 mA: $U_i = 30\text{ V}^{1)}$ $I_i = 300\text{ mA}$ $P_i = 1\text{ W}$ effective inner inductance $L_i = 0$ effective inner capacitance $C_i = 30\text{ nF}$

1) For functional reasons, input may be limited to a reduced supply voltage of  $28\text{ V}_{\text{DC}}$

**Electronics compartment, intrinsically safe (AEx ia/Ex ia)****Service interface (CDI)**

Taking the following values into consideration, the device can be connected to the certified Endress+Hauser FXA291 service tool or a similar interface:

Service interface													
$U_i = 7.3 \text{ V}$ effective inner inductance $L_i = \text{negligible}$ effective inner capacitance $C_i = \text{negligible}$													
$U_o = 7.3 \text{ V}$ $I_o = 60 \text{ mA}$ $P_o = 110 \text{ mW}$													
$L_o \text{ (mH)} =$	5.00	2.00	1.00	0.50	0.20	0.15	0.10	0.05	0.02	0.01	0.005	0.002	0.001
$C_o \text{ (}\mu\text{F)}^{1) =}$	0.73	1.20	1.60	2.00	2.60	-	3.20	4.00	5.50	7.30	10.00	12.70	12.70
$C_o \text{ (}\mu\text{F)}^{2) =}$	-	0.49	0.90	1.40	-	2.00	-	-	-	-	-	-	-

1) Values according to PTB "ispark" program

2) Values according to IEC/EN 60079-25, Annex C

**Remote display interface**

- Devices with *Basic specification, Position 4 (Display, Operation) = L, M, N* can be connected to the approved Endress+Hauser remote display FHX50.
- Refer to Safety Instructions XA01095F for additional installation instructions.

# Micropilot FMR60, FMR62, FMR67

4-20 mA HART

## Table of contents

Notes on the structure .....	20
Example diagrams of possible deratings .....	22
Intrinsically safe (IS) AEx/Ex ia IIC .....	23
Nonincendive Field Wiring (NIFW) .....	32
Standard Div. 2 Wiring .....	37
Class II, III, Div. 1 .....	42

## Notes on the structure

## Extract from the extended order code

## Device type

FMR60, FMR62, FMR67

## Basic specifications

Position 1, 2 (Approval)		
Selected option		Description
FMR6x	FA	FM IS Cl.I Div.1 Gr.A-D
	FB	FM IS Cl.I,II,III Div.1 Gr.A-G, AEx ia, NI Cl.1 Div.2
	8A	FM/CSA IS+XP-IS Cl.I Div.1 Gr.A-D, DIP-IS Cl.II,III Div.1 Gr.E-G
FMR62	FF	FM IS Cl.I Div.1 Gr.A-D, AEx ia, NI Cl.1 Div.2

Position 5 (Housing)		
Selected option		Description
FMR6x	A <sup>1)</sup>	GT19 dual compartment, plastic PBT
	C	GT20 dual compartment, Alu, coated
FMR62 FMR67	B	GT18 dual compartment, 316L

1) Only in connection with Position 1, 2 (Approval) = FA

Position 7, 8 (Antenna)		
Selected option		Description
FMR60	GA	Drip-off, PTFE DN50
FMR62	GE	Integrated, PEEK, 3/4"
	GF	Integrated, PEEK, 1-1/2"
	GM	PTFE cladded flush mount DN50
	GN	PTFE cladded flush mount DN80
FMR67	GA	Drip-off, PTFE DN50
	GP	PTFE flush mount DN80

Position 9, 10 (Seal)		
Selected option		Description
FMR60	A3	FKM Viton GLT, -40...80°C/-40...176°F
	A4	FKM Viton GLT, -40...130°C/-40...266°F
	C1 <sup>1)</sup>	FFKM Kalrez, -20...150°C/-4...302°F
	B4 <sup>1)</sup>	EPDM, -40...150°C/-40...302°F
FMR62	A5	FKM Viton GLT, -40...150°C/-40...302°F
	A6	FKM Viton GLT, -40...200°C/-40...392°F
	C1	FFKM Kalrez, -20...150°C/-4...302°F
	C2	FFKM Kalrez, -20...200°C/-4...392°F
	F5	PTFE cladded, -40...150°C/-40...302°F
	F6	PTFE cladded, -40...200°C/-40...392°F

Position 9, 10 (Seal)		
Selected option		Description
FMR67	A3	FKM Viton GLT, -40...80°C/-40...176°F
	A5	FKM Viton GLT, -40...150°C/-40...302°F
	A6	FKM Viton GLT, -40...200°C/-40...392°F

1) Only in connection with Position 1, 2 (Approval) = FA, FB, FF

**General notes**

**i** *Optional specification, ID Nx (Accessory Mounted) = NA (Overvoltage protection type OVP10 and type OVP20)*  
 When using the internal overvoltage protection: Reduce the admissible ambient temperature at the housing by 2 K.

*Basic specification, Position 5 (Housing) = A*  
 When using the remote display FHX50: Reduce the admissible ambient temperature at the housing by 3 K.

**i** Observe the permitted temperature range at the antenna.

**Description notes**

**i** Unless otherwise indicated, the positions always refer to the basic specification.

Class I, Div. 1 or Div. 2

1st column: Temperature classes T6 (85 °C) to T1 (450 °C)

Column P1 to P5: Position (temperature value) on the axes of the derating

- T<sub>a</sub>: Ambient temperature in °C
- T<sub>p</sub>: Process temperature in °C

	P1		P2		P2+		P3		P4		P5	
	T <sub>p</sub>	T <sub>a</sub>	T <sub>p</sub>	T <sub>a</sub>	T <sub>p</sub>	T <sub>a</sub>	T <sub>p</sub>	T <sub>a</sub>	T <sub>p</sub>	T <sub>a</sub>	T <sub>p</sub>	T <sub>a</sub>
T6	-40	51	51	51	-	-	85	45	85	-40	-40	-40
T5	-40	64	64	64	-	-	100	58	100	-40	-40	-40
T4	-40	64	64	64	-	-	135	52	135	-40	-40	-40

A0031752-EN

**i** Column P2+ is only relevant for version B of the derating.  
 → 22

Class II, III, Div. 1

1st column: Process temperature

Column P1 to P5: Position (temperature value) on the axes of the derating

- T<sub>a</sub>: Ambient temperature in °C
- T<sub>p</sub>: Process temperature in °C

	P1		P2		P3		P4		P5	
	T <sub>p</sub>	T <sub>a</sub>	T <sub>p</sub>	T <sub>a</sub>	T <sub>p</sub>	T <sub>a</sub>	T <sub>p</sub>	T <sub>a</sub>	T <sub>p</sub>	T <sub>a</sub>
100	-40	75	75	75	100	58	100	-40	-40	-40
135	-40	75	75	75	135	52	135	-40	-40	-40
150	-40	75	75	75	150	47	150	-40	-40	-40

A0033298-EN

Example diagrams  
of possible deratings

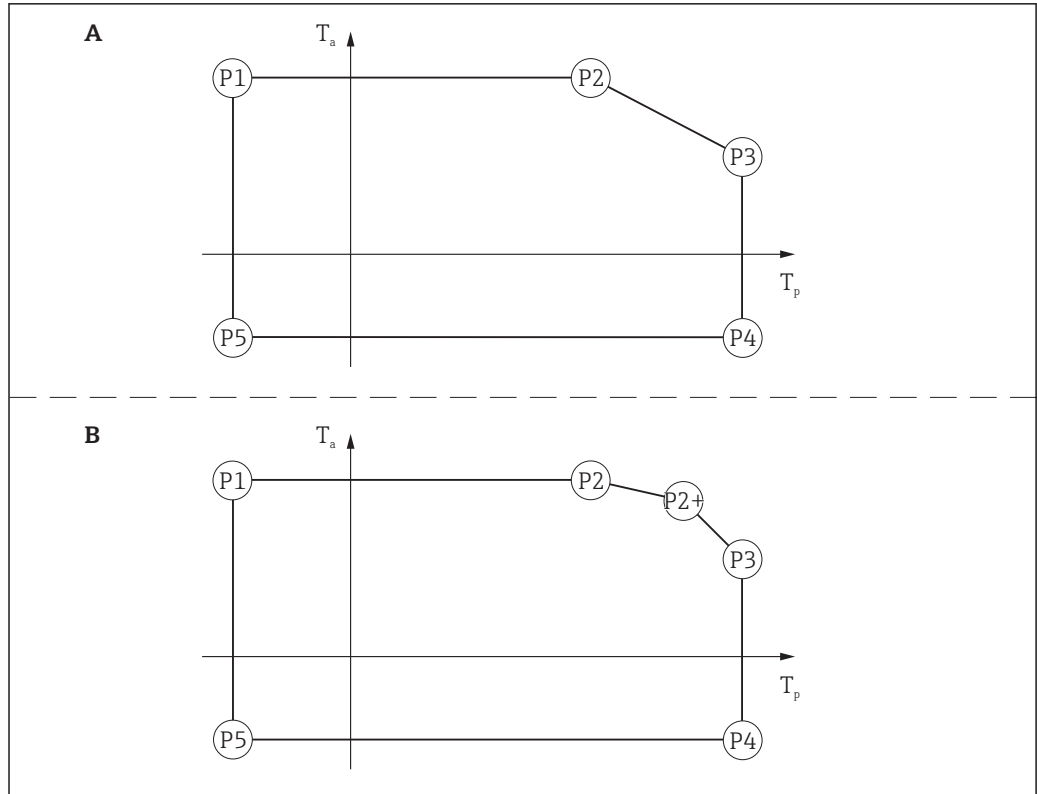

A0031943

4

**Intrinsically safe (IS)**  
**AEx/Ex ia IIC**

Antenna: Class I, Zone 0 / Class I, Div. 1; Electronics housing: Class I, Zone 1 / Class I, Div. 1  
Page references to the temperature tables of the respective device types: See the following list.

- FMR60 → 23
- FMR62 → 25
- FMR67 → 29

**FMR60**

*Position 7, 8 (Antenna) = GA*

*Position 9, 10 (Seal) = A3*

*Position 5 (Housing) = A*

	P1		P2		P2+		P3		P4		P5	
	T <sub>p</sub>	T <sub>a</sub>	T <sub>p</sub>	T <sub>a</sub>	T <sub>p</sub>	T <sub>a</sub>	T <sub>p</sub>	T <sub>a</sub>	T <sub>p</sub>	T <sub>a</sub>	T <sub>p</sub>	T <sub>a</sub>
T6	-40	43	43	43	-	-	80	32	80	-40	-40	-40

*Position 5 (Housing) = C*

	P1		P2		P2+		P3		P4		P5	
	T <sub>p</sub>	T <sub>a</sub>	T <sub>p</sub>	T <sub>a</sub>	T <sub>p</sub>	T <sub>a</sub>	T <sub>p</sub>	T <sub>a</sub>	T <sub>p</sub>	T <sub>a</sub>	T <sub>p</sub>	T <sub>a</sub>
T6	-40	51	51	51	-	-	80	47	80	-40	-40	-40

**FMR60**

*Position 7, 8 (Antenna) = GA*

*Position 9, 10 (Seal) = A4*

*Position 5 (Housing) = A*

	P1		P2		P2+		P3		P4		P5	
	T <sub>p</sub>	T <sub>a</sub>	T <sub>p</sub>	T <sub>a</sub>	T <sub>p</sub>	T <sub>a</sub>	T <sub>p</sub>	T <sub>a</sub>	T <sub>p</sub>	T <sub>a</sub>	T <sub>p</sub>	T <sub>a</sub>
T6	-40	43	43	43	79	33	85	25	85	-40	-40	-40
T5	-40	56	56	56	96	45	100	40	100	-40	-40	-40
T4	-40	56	56	56	117	39	130	22	130	-40	-40	-40

*Position 5 (Housing) = C*

	P1		P2		P2+		P3		P4		P5	
	T <sub>p</sub>	T <sub>a</sub>	T <sub>p</sub>	T <sub>a</sub>	T <sub>p</sub>	T <sub>a</sub>	T <sub>p</sub>	T <sub>a</sub>	T <sub>p</sub>	T <sub>a</sub>	T <sub>p</sub>	T <sub>a</sub>
T6	-40	51	51	51	-	-	85	46	85	-40	-40	-40
T5	-40	64	64	64	-	-	100	59	100	-40	-40	-40
T4	-40	64	64	64	-	-	130	54	130	-40	-40	-40

**FMR60***Position 7, 8 (Antenna) = GA**Position 9, 10 (Seal) = C1**Position 5 (Housing) = A*

	P1		P2		P2+		P3		P4		P5	
	T <sub>p</sub>	T <sub>a</sub>	T <sub>p</sub>	T <sub>a</sub>	T <sub>p</sub>	T <sub>a</sub>	T <sub>p</sub>	T <sub>a</sub>	T <sub>p</sub>	T <sub>a</sub>	T <sub>p</sub>	T <sub>a</sub>
T6	-20	43	43	43	79	33	85	25	85	-20	-20	-20
T5	-20	56	56	56	96	45	100	40	100	-20	-20	-20
T4	-20	56	56	56	117	39	135	15	135	-20	-20	-20

*Position 5 (Housing) = C*

	P1		P2		P2+		P3		P4		P5	
	T <sub>p</sub>	T <sub>a</sub>	T <sub>p</sub>	T <sub>a</sub>	T <sub>p</sub>	T <sub>a</sub>	T <sub>p</sub>	T <sub>a</sub>	T <sub>p</sub>	T <sub>a</sub>	T <sub>p</sub>	T <sub>a</sub>
T6	-20	51	51	51	-	-	85	46	85	-20	-20	-20
T5	-20	64	64	64	-	-	100	59	100	-20	-20	-20
T4	-20	64	64	64	-	-	135	54	135	-20	-20	-20
T3	-20	64	64	64	-	-	150	50	150	-20	-20	-20

**FMR60***Position 7, 8 (Antenna) = GA**Position 9, 10 (Seal) = B4**Position 5 (Housing) = A*

	P1		P2		P2+		P3		P4		P5	
	T <sub>p</sub>	T <sub>a</sub>	T <sub>p</sub>	T <sub>a</sub>	T <sub>p</sub>	T <sub>a</sub>	T <sub>p</sub>	T <sub>a</sub>	T <sub>p</sub>	T <sub>a</sub>	T <sub>p</sub>	T <sub>a</sub>
T6	-40	43	43	43	79	33	85	25	85	-40	-40	-40
T5	-40	56	56	56	96	45	100	40	100	-40	-40	-40
T4	-40	56	56	56	117	39	135	15	135	-40	-40	-40

*Position 5 (Housing) = C*

	P1		P2		P2+		P3		P4		P5	
	T <sub>p</sub>	T <sub>a</sub>	T <sub>p</sub>	T <sub>a</sub>	T <sub>p</sub>	T <sub>a</sub>	T <sub>p</sub>	T <sub>a</sub>	T <sub>p</sub>	T <sub>a</sub>	T <sub>p</sub>	T <sub>a</sub>
T6	-40	51	51	51	-	-	85	46	85	-40	-40	-40
T5	-40	64	64	64	-	-	100	59	100	-40	-40	-40
T4	-40	64	64	64	-	-	135	54	135	-40	-40	-40
T3	-40	64	64	64	-	-	150	50	150	-40	-40	-40



**FMR62**

Position 7, 8 (Antenna) = GE, GF, GM, GN

Position 9, 10 (Seal) = A5, F5

Position 5 (Housing) = A

	P1		P2		P2+		P3		P4		P5	
	T <sub>p</sub>	T <sub>a</sub>	T <sub>p</sub>	T <sub>a</sub>	T <sub>p</sub>	T <sub>a</sub>	T <sub>p</sub>	T <sub>a</sub>	T <sub>p</sub>	T <sub>a</sub>	T <sub>p</sub>	T <sub>a</sub>
T6	-40	43	43	43	-	-	85	34	85	-40	-40	-40
T5	-40	56	56	56	-	-	100	46	100	-40	-40	-40
T4	-40	56	56	56	-	-	135	38	135	-40	-40	-40
T3	-40	56	56	56	134	39	150	24	150	-40	-40	-40

Position 5 (Housing) = B

	P1		P2		P2+		P3		P4		P5	
	T <sub>p</sub>	T <sub>a</sub>	T <sub>p</sub>	T <sub>a</sub>	T <sub>p</sub>	T <sub>a</sub>	T <sub>p</sub>	T <sub>a</sub>	T <sub>p</sub>	T <sub>a</sub>	T <sub>p</sub>	T <sub>a</sub>
T6	-40	51	51	51	-	-	85	45	85	-40	-40	-40
T5	-40	64	64	64	-	-	100	58	100	-40	-40	-40
T4	-40	64	64	64	-	-	135	52	135	-40	-40	-40
T3	-40	64	64	64	-	-	150	47	150	-40	-40	-40

Position 5 (Housing) = C

	P1		P2		P2+		P3		P4		P5	
	T <sub>p</sub>	T <sub>a</sub>	T <sub>p</sub>	T <sub>a</sub>	T <sub>p</sub>	T <sub>a</sub>	T <sub>p</sub>	T <sub>a</sub>	T <sub>p</sub>	T <sub>a</sub>	T <sub>p</sub>	T <sub>a</sub>
T6	-40	51	51	51	-	-	85	47	85	-40	-40	-40
T5	-40	64	64	64	-	-	100	60	100	-40	-40	-40
T4	-40	64	64	64	-	-	135	56	135	-40	-40	-40
T3	-40	64	64	64	-	-	150	54	150	-40	-40	-40

**FMR62***Position 7, 8 (Antenna) = GE, GF, GM, GN**Position 9, 10 (Seal) = A6, F6**Position 5 (Housing) = A*

	P1		P2		P2+		P3		P4		P5	
	T <sub>p</sub>	T <sub>a</sub>	T <sub>p</sub>	T <sub>a</sub>	T <sub>p</sub>	T <sub>a</sub>	T <sub>p</sub>	T <sub>a</sub>	T <sub>p</sub>	T <sub>a</sub>	T <sub>p</sub>	T <sub>a</sub>
T6	-40	43	43	43	-	-	85	38	85	-40	-40	-40
T5	-40	56	56	56	-	-	100	51	100	-40	-40	-40
T4	-40	56	56	56	-	-	135	47	135	-40	-40	-40
T3	-40	56	56	56	-	-	200	40	200	-40	-40	-40

*Position 5 (Housing) = B, C*

	P1		P2		P2+		P3		P4		P5	
	T <sub>p</sub>	T <sub>a</sub>	T <sub>p</sub>	T <sub>a</sub>	T <sub>p</sub>	T <sub>a</sub>	T <sub>p</sub>	T <sub>a</sub>	T <sub>p</sub>	T <sub>a</sub>	T <sub>p</sub>	T <sub>a</sub>
T6	-40	51	51	51	-	-	85	48	85	-40	-40	-40
T5	-40	64	64	64	-	-	100	61	100	-40	-40	-40
T4	-40	64	64	64	-	-	135	58	135	-40	-40	-40
T3	-40	64	64	64	-	-	200	53	200	-40	-40	-40

**FMR62***Position 7, 8 (Antenna) = GE, GF, GM, GN**Position 9, 10 (Seal) = C1**Position 5 (Housing) = A*

	P1		P2		P2+		P3		P4		P5	
	T <sub>p</sub>	T <sub>a</sub>	T <sub>p</sub>	T <sub>a</sub>	T <sub>p</sub>	T <sub>a</sub>	T <sub>p</sub>	T <sub>a</sub>	T <sub>p</sub>	T <sub>a</sub>	T <sub>p</sub>	T <sub>a</sub>
T6	-20	43	43	43	-	-	85	34	85	-20	-20	-20
T5	-20	56	56	56	-	-	100	46	100	-20	-20	-20
T4	-20	56	56	56	-	-	135	38	135	-20	-20	-20
T3	-20	56	56	56	134	39	150	24	150	-20	-20	-20

*Position 5 (Housing) = B*

	P1		P2		P2+		P3		P4		P5	
	T <sub>p</sub>	T <sub>a</sub>	T <sub>p</sub>	T <sub>a</sub>	T <sub>p</sub>	T <sub>a</sub>	T <sub>p</sub>	T <sub>a</sub>	T <sub>p</sub>	T <sub>a</sub>	T <sub>p</sub>	T <sub>a</sub>
T6	-20	51	51	51	-	-	85	45	85	-20	-20	-20
T5	-20	64	64	64	-	-	100	58	100	-20	-20	-20
T4	-20	64	64	64	-	-	135	52	135	-20	-20	-20
T3	-20	64	64	64	-	-	150	47	150	-20	-20	-20

*Position 5 (Housing) = C*

	P1		P2		P2+		P3		P4		P5	
	T <sub>p</sub>	T <sub>a</sub>	T <sub>p</sub>	T <sub>a</sub>	T <sub>p</sub>	T <sub>a</sub>	T <sub>p</sub>	T <sub>a</sub>	T <sub>p</sub>	T <sub>a</sub>	T <sub>p</sub>	T <sub>a</sub>
T6	-20	51	51	51	-	-	85	47	85	-20	-20	-20
T5	-20	64	64	64	-	-	100	60	100	-20	-20	-20
T4	-20	64	64	64	-	-	135	56	135	-20	-20	-20
T3	-20	64	64	64	-	-	150	54	150	-20	-20	-20

**FMR62***Position 7, 8 (Antenna) = GE, GF, GM, GN**Position 9, 10 (Seal) = C2**Position 5 (Housing) = A*

	P1		P2		P2+		P3		P4		P5	
	T <sub>p</sub>	T <sub>a</sub>	T <sub>p</sub>	T <sub>a</sub>	T <sub>p</sub>	T <sub>a</sub>	T <sub>p</sub>	T <sub>a</sub>	T <sub>p</sub>	T <sub>a</sub>	T <sub>p</sub>	T <sub>a</sub>
T6	-20	43	43	43	-	-	85	38	85	-20	-20	-20
T5	-20	56	56	56	-	-	100	51	100	-20	-20	-20
T4	-20	56	56	56	-	-	135	47	135	-20	-20	-20
T3	-20	56	56	56	-	-	200	40	200	-20	-20	-20

*Position 5 (Housing) = B, C*

	P1		P2		P2+		P3		P4		P5	
	T <sub>p</sub>	T <sub>a</sub>	T <sub>p</sub>	T <sub>a</sub>	T <sub>p</sub>	T <sub>a</sub>	T <sub>p</sub>	T <sub>a</sub>	T <sub>p</sub>	T <sub>a</sub>	T <sub>p</sub>	T <sub>a</sub>
T6	-20	51	51	51	-	-	85	48	85	-20	-20	-20
T5	-20	64	64	64	-	-	100	61	100	-20	-20	-20
T4	-20	64	64	64	-	-	135	58	135	-20	-20	-20
T3	-20	64	64	64	-	-	200	53	200	-20	-20	-20

**FMR67**

*Position 7, 8 (Antenna) = GA*

*Position 9, 10 (Seal) = A3*

*Position 5 (Housing) = A*

	P1		P2		P2+		P3		P4		P5	
	T <sub>p</sub>	T <sub>a</sub>	T <sub>p</sub>	T <sub>a</sub>	T <sub>p</sub>	T <sub>a</sub>	T <sub>p</sub>	T <sub>a</sub>	T <sub>p</sub>	T <sub>a</sub>	T <sub>p</sub>	T <sub>a</sub>
T6	-40	43	43	43	-	-	80	32	80	-40	-40	-40

*Position 5 (Housing) = B*

	P1		P2		P2+		P3		P4		P5	
	T <sub>p</sub>	T <sub>a</sub>	T <sub>p</sub>	T <sub>a</sub>	T <sub>p</sub>	T <sub>a</sub>	T <sub>p</sub>	T <sub>a</sub>	T <sub>p</sub>	T <sub>a</sub>	T <sub>p</sub>	T <sub>a</sub>
T6	-40	51	51	51	-	-	80	43	80	-40	-40	-40

*Position 5 (Housing) = C*

	P1		P2		P2+		P3		P4		P5	
	T <sub>p</sub>	T <sub>a</sub>	T <sub>p</sub>	T <sub>a</sub>	T <sub>p</sub>	T <sub>a</sub>	T <sub>p</sub>	T <sub>a</sub>	T <sub>p</sub>	T <sub>a</sub>	T <sub>p</sub>	T <sub>a</sub>
T6	-40	51	51	51	-	-	80	47	80	-40	-40	-40

**FMR67***Position 7, 8 (Antenna) = GP**Position 9, 10 (Seal) = A5**Position 5 (Housing) = A*

	P1		P2		P2+		P3		P4		P5	
	T <sub>p</sub>	T <sub>a</sub>	T <sub>p</sub>	T <sub>a</sub>	T <sub>p</sub>	T <sub>a</sub>	T <sub>p</sub>	T <sub>a</sub>	T <sub>p</sub>	T <sub>a</sub>	T <sub>p</sub>	T <sub>a</sub>
T6	-40	43	43	43	-	-	85	34	85	-40	-40	-40
T5	-40	56	56	56	-	-	100	46	100	-40	-40	-40
T4	-40	56	56	56	-	-	135	38	135	-40	-40	-40
T3	-40	56	56	56	134	39	150	24	150	-40	-40	-40

*Position 5 (Housing) = B*

	P1		P2		P2+		P3		P4		P5	
	T <sub>p</sub>	T <sub>a</sub>	T <sub>p</sub>	T <sub>a</sub>	T <sub>p</sub>	T <sub>a</sub>	T <sub>p</sub>	T <sub>a</sub>	T <sub>p</sub>	T <sub>a</sub>	T <sub>p</sub>	T <sub>a</sub>
T6	-40	51	51	51	-	-	85	45	85	-40	-40	-40
T5	-40	64	64	64	-	-	100	58	100	-40	-40	-40
T4	-40	64	64	64	-	-	135	52	135	-40	-40	-40
T3	-40	64	64	64	-	-	150	47	150	-40	-40	-40

*Position 5 (Housing) = C*

	P1		P2		P2+		P3		P4		P5	
	T <sub>p</sub>	T <sub>a</sub>	T <sub>p</sub>	T <sub>a</sub>	T <sub>p</sub>	T <sub>a</sub>	T <sub>p</sub>	T <sub>a</sub>	T <sub>p</sub>	T <sub>a</sub>	T <sub>p</sub>	T <sub>a</sub>
T6	-40	51	51	51	-	-	85	47	85	-40	-40	-40
T5	-40	64	64	64	-	-	100	60	100	-40	-40	-40
T4	-40	64	64	64	-	-	135	56	135	-40	-40	-40
T3	-40	64	64	64	-	-	150	54	150	-40	-40	-40

**FMR67***Position 7, 8 (Antenna) = GP**Position 9, 10 (Seal) = A6**Position 5 (Housing) = A*

	P1		P2		P2+		P3		P4		P5	
	T <sub>p</sub>	T <sub>a</sub>	T <sub>p</sub>	T <sub>a</sub>	T <sub>p</sub>	T <sub>a</sub>	T <sub>p</sub>	T <sub>a</sub>	T <sub>p</sub>	T <sub>a</sub>	T <sub>p</sub>	T <sub>a</sub>
T6	-40	43	43	43	-	-	85	38	85	-40	-40	-40
T5	-40	56	56	56	-	-	100	51	100	-40	-40	-40
T4	-40	56	56	56	-	-	135	47	135	-40	-40	-40
T3	-40	56	56	56	-	-	200	40	200	-40	-40	-40

*Position 5 (Housing) = B, C*

	P1		P2		P2+		P3		P4		P5	
	T <sub>p</sub>	T <sub>a</sub>	T <sub>p</sub>	T <sub>a</sub>	T <sub>p</sub>	T <sub>a</sub>	T <sub>p</sub>	T <sub>a</sub>	T <sub>p</sub>	T <sub>a</sub>	T <sub>p</sub>	T <sub>a</sub>
T6	-40	51	51	51	-	-	85	48	85	-40	-40	-40
T5	-40	64	64	64	-	-	100	61	100	-40	-40	-40
T4	-40	64	64	64	-	-	135	58	135	-40	-40	-40
T3	-40	64	64	64	-	-	200	53	200	-40	-40	-40

**Nonincendive Field Wiring (NIFW)**

Antenna: Class I, Zone 0 or Zone 1 / Class I, Div. 1 or Div. 2; Electronics housing: Class I, Div. 2  
 Page references to the temperature tables of the respective device types: See the following list.

- FMR60 → 32
- FMR62 → 34
- FMR67 → 36

**FMR60**

*Position 7, 8 (Antenna) = GA*

*Position 9, 10 (Seal) = A3*

*Position 5 (Housing) = C*

	P1		P2		P2+		P3		P4		P5	
	T <sub>p</sub>	T <sub>a</sub>	T <sub>p</sub>	T <sub>a</sub>	T <sub>p</sub>	T <sub>a</sub>	T <sub>p</sub>	T <sub>a</sub>	T <sub>p</sub>	T <sub>a</sub>	T <sub>p</sub>	T <sub>a</sub>
T6	-40	51	51	51	-	-	80	47	80	-40	-40	-40

**FMR60**

*Position 7, 8 (Antenna) = GA*

*Position 9, 10 (Seal) = A4*

*Position 5 (Housing) = C*

	P1		P2		P2+		P3		P4		P5	
	T <sub>p</sub>	T <sub>a</sub>	T <sub>p</sub>	T <sub>a</sub>	T <sub>p</sub>	T <sub>a</sub>	T <sub>p</sub>	T <sub>a</sub>	T <sub>p</sub>	T <sub>a</sub>	T <sub>p</sub>	T <sub>a</sub>
T6	-40	51	51	51	-	-	85	46	85	-40	-40	-40
T5	-40	64	64	64	-	-	100	59	100	-40	-40	-40
T4	-40	64	64	64	-	-	130	54	130	-40	-40	-40



**FMR60***Position 7, 8 (Antenna) = GA**Position 9, 10 (Seal) = C1**Position 5 (Housing) = C*

	P1		P2		P2+		P3		P4		P5	
	T <sub>p</sub>	T <sub>a</sub>	T <sub>p</sub>	T <sub>a</sub>	T <sub>p</sub>	T <sub>a</sub>	T <sub>p</sub>	T <sub>a</sub>	T <sub>p</sub>	T <sub>a</sub>	T <sub>p</sub>	T <sub>a</sub>
T6	-20	51	51	51	-	-	85	46	85	-20	-20	-20
T5	-20	64	64	64	-	-	100	59	100	-20	-20	-20
T4	-20	64	64	64	-	-	135	54	135	-20	-20	-20
T3	-20	64	64	64	-	-	150	50	150	-20	-20	-20

**FMR60***Position 7, 8 (Antenna) = GA**Position 9, 10 (Seal) = B4**Position 5 (Housing) = C*

	P1		P2		P2+		P3		P4		P5	
	T <sub>p</sub>	T <sub>a</sub>	T <sub>p</sub>	T <sub>a</sub>	T <sub>p</sub>	T <sub>a</sub>	T <sub>p</sub>	T <sub>a</sub>	T <sub>p</sub>	T <sub>a</sub>	T <sub>p</sub>	T <sub>a</sub>
T6	-40	51	51	51	-	-	85	46	85	-40	-40	-40
T5	-40	64	64	64	-	-	100	59	100	-40	-40	-40
T4	-40	64	64	64	-	-	135	54	135	-40	-40	-40
T3	-40	64	64	64	-	-	150	50	150	-40	-40	-40

**FMR62***Position 7, 8 (Antenna) = GE, GF, GM, GN**Position 9, 10 (Seal) = A5, F5**Position 5 (Housing) = B*

	P1		P2		P2+		P3		P4		P5	
	T <sub>p</sub>	T <sub>a</sub>	T <sub>p</sub>	T <sub>a</sub>	T <sub>p</sub>	T <sub>a</sub>	T <sub>p</sub>	T <sub>a</sub>	T <sub>p</sub>	T <sub>a</sub>	T <sub>p</sub>	T <sub>a</sub>
T6	-40	51	51	51	-	-	85	45	85	-40	-40	-40
T5	-40	64	64	64	-	-	100	58	100	-40	-40	-40
T4	-40	64	64	64	-	-	135	52	135	-40	-40	-40
T3	-40	64	64	64	-	-	150	47	150	-40	-40	-40

*Position 5 (Housing) = C*

	P1		P2		P2+		P3		P4		P5	
	T <sub>p</sub>	T <sub>a</sub>	T <sub>p</sub>	T <sub>a</sub>	T <sub>p</sub>	T <sub>a</sub>	T <sub>p</sub>	T <sub>a</sub>	T <sub>p</sub>	T <sub>a</sub>	T <sub>p</sub>	T <sub>a</sub>
T6	-40	51	51	51	-	-	85	47	85	-40	-40	-40
T5	-40	64	64	64	-	-	100	60	100	-40	-40	-40
T4	-40	64	64	64	-	-	135	56	135	-40	-40	-40
T3	-40	64	64	64	-	-	150	54	150	-40	-40	-40

**FMR62***Position 7, 8 (Antenna) = GE, GF, GM, GN**Position 9, 10 (Seal) = A6, F6**Position 5 (Housing) = B, C*

	P1		P2		P2+		P3		P4		P5	
	T <sub>p</sub>	T <sub>a</sub>	T <sub>p</sub>	T <sub>a</sub>	T <sub>p</sub>	T <sub>a</sub>	T <sub>p</sub>	T <sub>a</sub>	T <sub>p</sub>	T <sub>a</sub>	T <sub>p</sub>	T <sub>a</sub>
T6	-40	51	51	51	-	-	85	48	85	-40	-40	-40
T5	-40	64	64	64	-	-	100	61	100	-40	-40	-40
T4	-40	64	64	64	-	-	135	58	135	-40	-40	-40
T3	-40	64	64	64	-	-	200	53	200	-40	-40	-40

**FMR62**

Position 7, 8 (Antenna) = GE, GF, GM, GN

Position 9, 10 (Seal) = C1

Position 5 (Housing) = B

	P1		P2		P2+		P3		P4		P5	
	T <sub>p</sub>	T <sub>a</sub>	T <sub>p</sub>	T <sub>a</sub>	T <sub>p</sub>	T <sub>a</sub>	T <sub>p</sub>	T <sub>a</sub>	T <sub>p</sub>	T <sub>a</sub>	T <sub>p</sub>	T <sub>a</sub>
T6	-20	51	51	51	-	-	85	45	85	-20	-20	-20
T5	-20	64	64	64	-	-	100	58	100	-20	-20	-20
T4	-20	64	64	64	-	-	135	52	135	-20	-20	-20
T3	-20	64	64	64	-	-	150	47	150	-20	-20	-20

Position 5 (Housing) = C

	P1		P2		P2+		P3		P4		P5	
	T <sub>p</sub>	T <sub>a</sub>	T <sub>p</sub>	T <sub>a</sub>	T <sub>p</sub>	T <sub>a</sub>	T <sub>p</sub>	T <sub>a</sub>	T <sub>p</sub>	T <sub>a</sub>	T <sub>p</sub>	T <sub>a</sub>
T6	-20	51	51	51	-	-	85	47	85	-20	-20	-20
T5	-20	64	64	64	-	-	100	60	100	-20	-20	-20
T4	-20	64	64	64	-	-	135	56	135	-20	-20	-20
T3	-20	64	64	64	-	-	150	54	150	-20	-20	-20

**FMR62**

Position 7, 8 (Antenna) = GE, GF, GM, GN

Position 9, 10 (Seal) = C2

Position 5 (Housing) = B, C

	P1		P2		P2+		P3		P4		P5	
	T <sub>p</sub>	T <sub>a</sub>	T <sub>p</sub>	T <sub>a</sub>	T <sub>p</sub>	T <sub>a</sub>	T <sub>p</sub>	T <sub>a</sub>	T <sub>p</sub>	T <sub>a</sub>	T <sub>p</sub>	T <sub>a</sub>
T6	-20	51	51	51	-	-	85	48	85	-20	-20	-20
T5	-20	64	64	64	-	-	100	61	100	-20	-20	-20
T4	-20	64	64	64	-	-	135	58	135	-20	-20	-20
T3	-20	64	64	64	-	-	200	53	200	-20	-20	-20

**FMR67***Position 7, 8 (Antenna) = GA**Position 9, 10 (Seal) = A3**Position 5 (Housing) = B*

	P1		P2		P2+		P3		P4		P5	
	T <sub>p</sub>	T <sub>a</sub>	T <sub>p</sub>	T <sub>a</sub>	T <sub>p</sub>	T <sub>a</sub>	T <sub>p</sub>	T <sub>a</sub>	T <sub>p</sub>	T <sub>a</sub>	T <sub>p</sub>	T <sub>a</sub>
T6	-40	51	51	51	-	-	80	43	80	-40	-40	-40

*Position 5 (Housing) = C*

	P1		P2		P2+		P3		P4		P5	
	T <sub>p</sub>	T <sub>a</sub>	T <sub>p</sub>	T <sub>a</sub>	T <sub>p</sub>	T <sub>a</sub>	T <sub>p</sub>	T <sub>a</sub>	T <sub>p</sub>	T <sub>a</sub>	T <sub>p</sub>	T <sub>a</sub>
T6	-40	51	51	51	-	-	80	47	80	-40	-40	-40

**FMR67***Position 7, 8 (Antenna) = GP**Position 9, 10 (Seal) = A5**Position 5 (Housing) = B*

	P1		P2		P2+		P3		P4		P5	
	T <sub>p</sub>	T <sub>a</sub>	T <sub>p</sub>	T <sub>a</sub>	T <sub>p</sub>	T <sub>a</sub>	T <sub>p</sub>	T <sub>a</sub>	T <sub>p</sub>	T <sub>a</sub>	T <sub>p</sub>	T <sub>a</sub>
T6	-40	51	51	51	-	-	85	45	85	-40	-40	-40
T5	-40	64	64	64	-	-	100	58	100	-40	-40	-40
T4	-40	64	64	64	-	-	135	52	135	-40	-40	-40
T3	-40	64	64	64	-	-	150	47	150	-40	-40	-40

*Position 5 (Housing) = C*

	P1		P2		P2+		P3		P4		P5	
	T <sub>p</sub>	T <sub>a</sub>	T <sub>p</sub>	T <sub>a</sub>	T <sub>p</sub>	T <sub>a</sub>	T <sub>p</sub>	T <sub>a</sub>	T <sub>p</sub>	T <sub>a</sub>	T <sub>p</sub>	T <sub>a</sub>
T6	-40	51	51	51	-	-	85	47	85	-40	-40	-40
T5	-40	64	64	64	-	-	100	60	100	-40	-40	-40
T4	-40	64	64	64	-	-	135	56	135	-40	-40	-40
T3	-40	64	64	64	-	-	150	54	150	-40	-40	-40

**FMR67***Position 7, 8 (Antenna) = GP**Position 9, 10 (Seal) = A6**Position 5 (Housing) = B, C*

	P1		P2		P2+		P3		P4		P5	
	T <sub>p</sub>	T <sub>a</sub>	T <sub>p</sub>	T <sub>a</sub>	T <sub>p</sub>	T <sub>a</sub>	T <sub>p</sub>	T <sub>a</sub>	T <sub>p</sub>	T <sub>a</sub>	T <sub>p</sub>	T <sub>a</sub>
T6	-40	51	51	51	-	-	85	48	85	-40	-40	-40
T5	-40	64	64	64	-	-	100	61	100	-40	-40	-40
T4	-40	64	64	64	-	-	135	58	135	-40	-40	-40
T3	-40	64	64	64	-	-	200	53	200	-40	-40	-40

**Standard Div. 2 Wiring**

Antenna: Class I, Zone 0 or Zone 1 / Class I, Div. 1 or Div. 2; Electronics housing: Class I, Div. 2  
 Page references to the temperature tables of the respective device types: See the following list.

- FMR60 → 37
- FMR62 → 39
- FMR67 → 41

**FMR60**

*Position 7, 8 (Antenna) = GA*

*Position 9, 10 (Seal) = A3*

*Position 5 (Housing) = C*

	P1		P2		P2+		P3		P4		P5	
	T <sub>p</sub>	T <sub>a</sub>	T <sub>p</sub>	T <sub>a</sub>	T <sub>p</sub>	T <sub>a</sub>	T <sub>p</sub>	T <sub>a</sub>	T <sub>p</sub>	T <sub>a</sub>	T <sub>p</sub>	T <sub>a</sub>
T6	-40	41	41	41	-	-	80	32	80	-40	-40	-40

**FMR60**

*Position 7, 8 (Antenna) = GA*

*Position 9, 10 (Seal) = A4*

*Position 5 (Housing) = C*

	P1		P2		P2+		P3		P4		P5	
	T <sub>p</sub>	T <sub>a</sub>	T <sub>p</sub>	T <sub>a</sub>	T <sub>p</sub>	T <sub>a</sub>	T <sub>p</sub>	T <sub>a</sub>	T <sub>p</sub>	T <sub>a</sub>	T <sub>p</sub>	T <sub>a</sub>
T6	-40	41	41	41	-	-	85	34	85	-40	-40	-40
T5	-40	56	56	56	-	-	100	49	100	-40	-40	-40
T4	-40	64	64	64	-	-	130	54	130	-40	-40	-40

**FMR60***Position 7, 8 (Antenna) = GA**Position 9, 10 (Seal) = C1**Position 5 (Housing) = C*

	P1		P2		P2+		P3		P4		P5	
	T <sub>p</sub>	T <sub>a</sub>	T <sub>p</sub>	T <sub>a</sub>	T <sub>p</sub>	T <sub>a</sub>	T <sub>p</sub>	T <sub>a</sub>	T <sub>p</sub>	T <sub>a</sub>	T <sub>p</sub>	T <sub>a</sub>
T6	-20	41	41	41	-	-	85	34	85	-20	-20	-20
T5	-20	56	56	56	-	-	100	49	100	-20	-20	-20
T4	-20	64	64	64	-	-	135	54	135	-20	-20	-20
T3	-20	64	64	64	-	-	150	50	150	-20	-20	-20

**FMR60***Position 7, 8 (Antenna) = GA**Position 9, 10 (Seal) = B4**Position 5 (Housing) = C*

	P1		P2		P2+		P3		P4		P5	
	T <sub>p</sub>	T <sub>a</sub>	T <sub>p</sub>	T <sub>a</sub>	T <sub>p</sub>	T <sub>a</sub>	T <sub>p</sub>	T <sub>a</sub>	T <sub>p</sub>	T <sub>a</sub>	T <sub>p</sub>	T <sub>a</sub>
T6	-40	41	41	41	-	-	85	34	85	-40	-40	-40
T5	-40	56	56	56	-	-	100	49	100	-40	-40	-40
T4	-40	64	64	64	-	-	135	54	135	-40	-40	-40
T3	-40	64	64	64	-	-	150	50	150	-40	-40	-40

**FMR62**

Position 7, 8 (Antenna) = GE, GF, GM, GN

Position 9, 10 (Seal) = A5, F5

Position 5 (Housing) = B

	P1		P2		P2+		P3		P4		P5	
	T <sub>p</sub>	T <sub>a</sub>	T <sub>p</sub>	T <sub>a</sub>	T <sub>p</sub>	T <sub>a</sub>	T <sub>p</sub>	T <sub>a</sub>	T <sub>p</sub>	T <sub>a</sub>	T <sub>p</sub>	T <sub>a</sub>
T6	-40	41	41	41	-	-	85	33	85	-40	-40	-40
T5	-40	56	56	56	-	-	100	48	100	-40	-40	-40
T4	-40	64	64	64	-	-	135	52	135	-40	-40	-40
T3	-40	64	64	64	-	-	150	47	150	-40	-40	-40

Position 5 (Housing) = C

	P1		P2		P2+		P3		P4		P5	
	T <sub>p</sub>	T <sub>a</sub>	T <sub>p</sub>	T <sub>a</sub>	T <sub>p</sub>	T <sub>a</sub>	T <sub>p</sub>	T <sub>a</sub>	T <sub>p</sub>	T <sub>a</sub>	T <sub>p</sub>	T <sub>a</sub>
T6	-40	41	41	41	-	-	85	36	85	-40	-40	-40
T5	-40	56	56	56	-	-	100	51	100	-40	-40	-40
T4	-40	64	64	64	-	-	135	56	135	-40	-40	-40
T3	-40	64	64	64	-	-	150	54	150	-40	-40	-40

**FMR62**

Position 7, 8 (Antenna) = GE, GF, GM, GN

Position 9, 10 (Seal) = A6, F6

Position 5 (Housing) = B, C

	P1		P2		P2+		P3		P4		P5	
	T <sub>p</sub>	T <sub>a</sub>	T <sub>p</sub>	T <sub>a</sub>	T <sub>p</sub>	T <sub>a</sub>	T <sub>p</sub>	T <sub>a</sub>	T <sub>p</sub>	T <sub>a</sub>	T <sub>p</sub>	T <sub>a</sub>
T6	-40	41	41	41	-	-	85	37	85	-40	-40	-40
T5	-40	56	56	56	-	-	100	52	100	-40	-40	-40
T4	-40	64	64	64	-	-	135	58	135	-40	-40	-40
T3	-40	64	64	64	-	-	200	53	200	-40	-40	-40

**FMR62***Position 7, 8 (Antenna) = GE, GF, GM, GN**Position 9, 10 (Seal) = C1**Position 5 (Housing) = B*

	P1		P2		P2+		P3		P4		P5	
	T <sub>p</sub>	T <sub>a</sub>	T <sub>p</sub>	T <sub>a</sub>	T <sub>p</sub>	T <sub>a</sub>	T <sub>p</sub>	T <sub>a</sub>	T <sub>p</sub>	T <sub>a</sub>	T <sub>p</sub>	T <sub>a</sub>
T6	-20	41	41	41	-	-	85	33	85	-20	-20	-20
T5	-20	56	56	56	-	-	100	48	100	-20	-20	-20
T4	-20	64	64	64	-	-	135	52	135	-20	-20	-20
T3	-20	64	64	64	-	-	150	47	150	-20	-20	-20

*Position 5 (Housing) = C*

	P1		P2		P2+		P3		P4		P5	
	T <sub>p</sub>	T <sub>a</sub>	T <sub>p</sub>	T <sub>a</sub>	T <sub>p</sub>	T <sub>a</sub>	T <sub>p</sub>	T <sub>a</sub>	T <sub>p</sub>	T <sub>a</sub>	T <sub>p</sub>	T <sub>a</sub>
T6	-20	41	41	41	-	-	85	36	85	-20	-20	-20
T5	-20	56	56	56	-	-	100	51	100	-20	-20	-20
T4	-20	64	64	64	-	-	135	56	135	-20	-20	-20
T3	-20	64	64	64	-	-	150	54	150	-20	-20	-20

**FMR62***Position 7, 8 (Antenna) = GE, GF, GM, GN**Position 9, 10 (Seal) = C2**Position 5 (Housing) = B, C*

	P1		P2		P2+		P3		P4		P5	
	T <sub>p</sub>	T <sub>a</sub>	T <sub>p</sub>	T <sub>a</sub>	T <sub>p</sub>	T <sub>a</sub>	T <sub>p</sub>	T <sub>a</sub>	T <sub>p</sub>	T <sub>a</sub>	T <sub>p</sub>	T <sub>a</sub>
T6	-20	41	41	41	-	-	85	37	85	-20	-20	-20
T5	-20	56	56	56	-	-	100	52	100	-20	-20	-20
T4	-20	64	64	64	-	-	135	58	135	-20	-20	-20
T3	-20	64	64	64	-	-	200	53	200	-20	-20	-20



**FMR67**

Position 7, 8 (Antenna) = GA

Position 9, 10 (Seal) = A3

Position 5 (Housing) = B, C

	P1		P2		P2+		P3		P4		P5	
	T <sub>p</sub>	T <sub>a</sub>	T <sub>p</sub>	T <sub>a</sub>	T <sub>p</sub>	T <sub>a</sub>	T <sub>p</sub>	T <sub>a</sub>	T <sub>p</sub>	T <sub>a</sub>	T <sub>p</sub>	T <sub>a</sub>
T6	-40	41	41	41	-	-	80	32	80	-40	-40	-40

**FMR67**

Position 7, 8 (Antenna) = GP

Position 9, 10 (Seal) = A5

Position 5 (Housing) = B

	P1		P2		P2+		P3		P4		P5	
	T <sub>p</sub>	T <sub>a</sub>	T <sub>p</sub>	T <sub>a</sub>	T <sub>p</sub>	T <sub>a</sub>	T <sub>p</sub>	T <sub>a</sub>	T <sub>p</sub>	T <sub>a</sub>	T <sub>p</sub>	T <sub>a</sub>
T6	-40	41	41	41	-	-	85	33	85	-40	-40	-40
T5	-40	56	56	56	-	-	100	48	100	-40	-40	-40
T4	-40	64	64	64	-	-	135	52	135	-40	-40	-40
T3	-40	64	64	64	-	-	150	47	150	-40	-40	-40

Position 5 (Housing) = C

	P1		P2		P2+		P3		P4		P5	
	T <sub>p</sub>	T <sub>a</sub>	T <sub>p</sub>	T <sub>a</sub>	T <sub>p</sub>	T <sub>a</sub>	T <sub>p</sub>	T <sub>a</sub>	T <sub>p</sub>	T <sub>a</sub>	T <sub>p</sub>	T <sub>a</sub>
T6	-40	41	41	41	-	-	85	36	85	-40	-40	-40
T5	-40	56	56	56	-	-	100	51	100	-40	-40	-40
T4	-40	64	64	64	-	-	135	56	135	-40	-40	-40
T3	-40	64	64	64	-	-	150	54	150	-40	-40	-40

**FMR67**

Position 7, 8 (Antenna) = GP

Position 9, 10 (Seal) = A6

Position 5 (Housing) = B, C

	P1		P2		P2+		P3		P4		P5	
	T <sub>p</sub>	T <sub>a</sub>	T <sub>p</sub>	T <sub>a</sub>	T <sub>p</sub>	T <sub>a</sub>	T <sub>p</sub>	T <sub>a</sub>	T <sub>p</sub>	T <sub>a</sub>	T <sub>p</sub>	T <sub>a</sub>
T6	-40	41	41	41	-	-	85	37	85	-40	-40	-40
T5	-40	56	56	56	-	-	100	52	100	-40	-40	-40
T4	-40	64	64	64	-	-	135	58	135	-40	-40	-40
T3	-40	64	64	64	-	-	200	53	200	-40	-40	-40

**Class II, III, Div. 1**

Antenna and electronics housing: Class II, III, Div. 1

Page references to the temperature tables of the respective device types: See the following list.

- FMR60 → 42
- FMR62 → 44
- FMR67 → 46

**FMR60**

Position 7, 8 (Antenna) = GA

Position 9, 10 (Seal) = A3

Position 5 (Housing) = C

	P1		P2		P3		P4		P5	
	T <sub>p</sub>	T <sub>a</sub>	T <sub>p</sub>	T <sub>a</sub>	T <sub>p</sub>	T <sub>a</sub>	T <sub>p</sub>	T <sub>a</sub>	T <sub>p</sub>	T <sub>a</sub>
75	-40	75	75	75	75	75	75	-40	-40	-40

**FMR60**

Position 7, 8 (Antenna) = GA

Position 9, 10 (Seal) = A4

Position 5 (Housing) = C

	P1		P2		P3		P4		P5	
	T <sub>p</sub>	T <sub>a</sub>	T <sub>p</sub>	T <sub>a</sub>	T <sub>p</sub>	T <sub>a</sub>	T <sub>p</sub>	T <sub>a</sub>	T <sub>p</sub>	T <sub>a</sub>
100	-40	75	75	75	100	59	100	-40	-40	-40
130	-40	75	75	75	130	54	130	-40	-40	-40

**FMR60**

*Position 7, 8 (Antenna) = GA*

*Position 9, 10 (Seal) = C1*

*Position 5 (Housing) = C*

	P1		P2		P3		P4		P5	
	T <sub>p</sub>	T <sub>a</sub>	T <sub>p</sub>	T <sub>a</sub>	T <sub>p</sub>	T <sub>a</sub>	T <sub>p</sub>	T <sub>a</sub>	T <sub>p</sub>	T <sub>a</sub>
100	-20	75	75	75	100	59	100	-20	-20	-20
135	-20	75	75	75	135	54	135	-20	-20	-20
150	-20	75	75	75	150	50	150	-20	-20	-20

**FMR60**

*Position 7, 8 (Antenna) = GA*

*Position 9, 10 (Seal) = B4*

*Position 5 (Housing) = C*

	P1		P2		P3		P4		P5	
	T <sub>p</sub>	T <sub>a</sub>	T <sub>p</sub>	T <sub>a</sub>	T <sub>p</sub>	T <sub>a</sub>	T <sub>p</sub>	T <sub>a</sub>	T <sub>p</sub>	T <sub>a</sub>
100	-40	75	75	75	100	59	100	-40	-40	-40
135	-40	75	75	75	135	54	135	-40	-40	-40
150	-40	75	75	75	150	50	150	-40	-40	-40

**FMR62**

Position 7, 8 (Antenna) = GE, GF, GM, GN

Position 9, 10 (Seal) = A5, F5

Position 5 (Housing) = B

	P1		P2		P3		P4		P5	
	T <sub>p</sub>	T <sub>a</sub>	T <sub>p</sub>	T <sub>a</sub>	T <sub>p</sub>	T <sub>a</sub>	T <sub>p</sub>	T <sub>a</sub>	T <sub>p</sub>	T <sub>a</sub>
100	-40	75	75	75	100	58	100	-40	-40	-40
135	-40	75	75	75	135	52	135	-40	-40	-40
150	-40	75	75	75	150	47	150	-40	-40	-40

Position 5 (Housing) = C

	P1		P2		P3		P4		P5	
	T <sub>p</sub>	T <sub>a</sub>	T <sub>p</sub>	T <sub>a</sub>	T <sub>p</sub>	T <sub>a</sub>	T <sub>p</sub>	T <sub>a</sub>	T <sub>p</sub>	T <sub>a</sub>
100	-40	75	75	75	100	60	100	-40	-40	-40
135	-40	75	75	75	135	56	135	-40	-40	-40
150	-40	75	75	75	150	54	150	-40	-40	-40

**FMR62**

Position 7, 8 (Antenna) = GE, GF, GM, GN

Position 9, 10 (Seal) = A6, F6

Position 5 (Housing) = B, C

	P1		P2		P3		P4		P5	
	T <sub>p</sub>	T <sub>a</sub>	T <sub>p</sub>	T <sub>a</sub>	T <sub>p</sub>	T <sub>a</sub>	T <sub>p</sub>	T <sub>a</sub>	T <sub>p</sub>	T <sub>a</sub>
100	-40	75	75	75	100	61	100	-40	-40	-40
135	-40	75	75	75	135	58	135	-40	-40	-40
200	-40	75	75	75	200	53	200	-40	-40	-40

**FMR62***Position 7, 8 (Antenna) = GE, GF, GM, GN**Position 9, 10 (Seal) = C1**Position 5 (Housing) = B*

	P1		P2		P3		P4		P5	
	T <sub>p</sub>	T <sub>a</sub>	T <sub>p</sub>	T <sub>a</sub>	T <sub>p</sub>	T <sub>a</sub>	T <sub>p</sub>	T <sub>a</sub>	T <sub>p</sub>	T <sub>a</sub>
100	-20	75	75	75	100	58	100	-20	-20	-20
135	-20	75	75	75	135	52	135	-20	-20	-20
150	-20	75	75	75	150	47	150	-20	-20	-20

*Position 5 (Housing) = C*

	P1		P2		P3		P4		P5	
	T <sub>p</sub>	T <sub>a</sub>	T <sub>p</sub>	T <sub>a</sub>	T <sub>p</sub>	T <sub>a</sub>	T <sub>p</sub>	T <sub>a</sub>	T <sub>p</sub>	T <sub>a</sub>
100	-20	75	75	75	100	60	100	-20	-20	-20
135	-20	75	75	75	135	56	135	-20	-20	-20
150	-20	75	75	75	150	54	150	-20	-20	-20

**FMR62***Position 7, 8 (Antenna) = GE, GF, GM, GN**Position 9, 10 (Seal) = C2**Position 5 (Housing) = B, C*

	P1		P2		P3		P4		P5	
	T <sub>p</sub>	T <sub>a</sub>	T <sub>p</sub>	T <sub>a</sub>	T <sub>p</sub>	T <sub>a</sub>	T <sub>p</sub>	T <sub>a</sub>	T <sub>p</sub>	T <sub>a</sub>
100	-20	75	75	75	100	61	100	-20	-20	-20
135	-20	75	75	75	135	58	135	-20	-20	-20
200	-20	75	75	75	200	53	200	-20	-20	-20

**FMR67***Position 7, 8 (Antenna) = GA**Position 9, 10 (Seal) = A3**Position 5 (Housing) = B, C*

	P1		P2		P3		P4		P5	
	T <sub>p</sub>	T <sub>a</sub>	T <sub>p</sub>	T <sub>a</sub>	T <sub>p</sub>	T <sub>a</sub>	T <sub>p</sub>	T <sub>a</sub>	T <sub>p</sub>	T <sub>a</sub>
75	-40	75	75	75	75	75	75	-40	-40	-40

**FMR67***Position 7, 8 (Antenna) = GP**Position 9, 10 (Seal) = A5**Position 5 (Housing) = B*

	P1		P2		P3		P4		P5	
	T <sub>p</sub>	T <sub>a</sub>	T <sub>p</sub>	T <sub>a</sub>	T <sub>p</sub>	T <sub>a</sub>	T <sub>p</sub>	T <sub>a</sub>	T <sub>p</sub>	T <sub>a</sub>
100	-40	75	75	75	100	58	100	-40	-40	-40
135	-40	75	75	75	135	52	135	-40	-40	-40
150	-40	75	75	75	150	47	150	-40	-40	-40

*Position 5 (Housing) = C*

	P1		P2		P3		P4		P5	
	T <sub>p</sub>	T <sub>a</sub>	T <sub>p</sub>	T <sub>a</sub>	T <sub>p</sub>	T <sub>a</sub>	T <sub>p</sub>	T <sub>a</sub>	T <sub>p</sub>	T <sub>a</sub>
100	-40	75	75	75	100	60	100	-40	-40	-40
135	-40	75	75	75	135	56	135	-40	-40	-40
150	-40	75	75	75	150	54	150	-40	-40	-40

**FMR67***Position 7, 8 (Antenna) = GP**Position 9, 10 (Seal) = A6**Position 5 (Housing) = B, C*

	P1		P2		P3		P4		P5	
	T <sub>p</sub>	T <sub>a</sub>	T <sub>p</sub>	T <sub>a</sub>	T <sub>p</sub>	T <sub>a</sub>	T <sub>p</sub>	T <sub>a</sub>	T <sub>p</sub>	T <sub>a</sub>
100	-40	75	75	75	100	61	100	-40	-40	-40
135	-40	75	75	75	135	58	135	-40	-40	-40
200	-40	75	75	75	200	53	200	-40	-40	-40

# Micropilot FMR60, FMR62, FMR67

4-20 mA HART

## Table of contents

Attachment: Nameplate view . . . . . 48

Attachment: Nameplate view

**Micropilot** Endress+Hauser

Order code: 8 IP68/66 Type 4X / 6P Encl.  
 Ser. no.: xxxxxxxx FM17.US0187X / FM17.CA0099X  
 Ext. ord. cd.: FMR6x-FABcdeffgghhh  
 IS CL I, DIV 1, GP A-D T6...T1

6  
 23  
 4...20 mA HART  
 27  
 Tp max = 12 MWP: 13  
 21 Ln =  
 Ta: -40...+80°C Ta > 60 °C:  $t_{\pm Ta} + 20 K$   
 Mat.: 15

See warning sign fixed to the enclosure.  
 Voir plaque d'avertissement fixée au boîtier.

52  
 XA01615F  
 X = if modification see sep. label Patents →  
 Date: JJJJ-MM

WARNINGS: Potential electrostatic charging hazard - see instructions. Substitution of components may impair suitability for hazardous locations.

AVERTISSEMENTS: Risque potentiel de décharges électrostatiques - voir consignes. La substitution de composants peut compromettre l'adaptabilité aux emplacements dangereux.

**Micropilot** Endress+Hauser

Order code: 8 IP68/66 Type 4X / 6P Encl.  
 Ser. no.: xxxxxxxx FM17.US0187X, FM17.CA0099X  
 Ext. ord. cd.: FMR6x-FBbcdeffgghhh  
 IS CL I, II, III, DIV 1, GP A-G T6...T1  
 CL I, Zn 0, AEx/Ex ia IIC T6...T1 Ga  
 NI CL I, DIV 2, GP A-D T6...T1

6  
 23  
 4...20 mA HART  
 27  
 Tp max = 12 MWP: 13  
 21 Ln =  
 Ta: -40...+80°C Ta > 60 °C:  $t_{\pm Ta} + 20 K$   
 Mat.: 15

See warning sign fixed to the enclosure.  
 Voir plaque d'avertissement fixée au boîtier.

52  
 XA01615F  
 X = if modification see sep. label Patents →  
 Date: JJJJ-MM

WARNINGS: Potential electrostatic charging hazard - see instructions. Substitution of components may impair suitability for hazardous locations. For Div. 2, do not disconnect equipment unless power has been switched off or area is known to be non-hazardous.

AVERTISSEMENTS: Risque potentiel de décharges électrostatiques - voir consignes. La substitution de composants peut compromettre l'adaptabilité aux emplacements dangereux. Pour Div. 2, débrancher appareil uniquement après avoir coupé l'alimentation l'électrique ou avoir vérifié qu'il ne soit pas installé en zone dangereuse.

**Micropilot** Endress+Hauser

Order code: 8 IP68/66 Type 4X / 6P Encl.  
 Ser. no.: xxxxxxxx FM17.US0187X, FM17.CA0099X  
 Ext. ord. cd.: FMR6x-FFbcdeffgghhh  
 IS CL I, DIV 1, GP A-D T6...T1  
 CL I, Zn 0, AEx/Ex ia IIC T6...T1 Ga  
 NI CL I, DIV 2, GP A-D T6...T1

6  
 23  
 4...20 mA HART  
 27  
 Tp max = 12 MWP: 13  
 21 Ln =  
 Ta: -40...+80°C Ta > 60 °C:  $t_{\pm Ta} + 20 K$   
 Mat.: 15

See warning sign fixed to the enclosure.  
 Voir plaque d'avertissement fixée au boîtier.

52  
 XA01615F  
 X = if modification see sep. label Patents →  
 Date: JJJJ-MM

WARNINGS: Potential electrostatic charging hazard - see instructions. Substitution of components may impair suitability for hazardous locations. For Div. 2, do not disconnect equipment unless power has been switched off or area is known to be non-hazardous.

AVERTISSEMENTS: Risque potentiel de décharges électrostatiques - voir consignes. La substitution de composants peut compromettre l'adaptabilité aux emplacements dangereux. Pour Div. 2, débrancher appareil uniquement après avoir coupé l'alimentation l'électrique ou avoir vérifié qu'il ne soit pas installé en zone dangereuse.

**Micropilot** Endress+Hauser

Order code: 8 IP68/66 Type 4X / 6P Encl.  
 Ser. no.: xxxxxxxx CRN OF 19773.5C  
 151079 CSA 17 70137829  
 Ext. ord. cd.: FMR6x-8Abcdeffgghhh  
 IS CL I, II, III, DIV 1, GP A-G T6...T1  
 XP-IS CL I, DIV 1, GP A-D T6...T1  
 DIP-IS CL II, III, DIV 1, GP E-G T6...T1  
 AIS CL I, II, III, DIV 1, GP A-G [Exia]

6  
 23  
 4...20 mA HART  
 27  
 Tp max = 12 MWP: 13  
 21 Ln =  
 Ta: -40...+80°C Ta > 60 °C:  $t_{\pm Ta} + 20 K$   
 Mat.: 15

See warning sign fixed to the enclosure.  
 Voir plaque d'avertissement fixée au boîtier.  
 FM17.US0187X, FM17.CA0099X

Dual Seal  
 XA01613F XA01612F  
 XA01616F XA01615F  
 X = if modification see sep. label Patents →  
 Date: JJJJ-MM

WARNINGS: Potential electrostatic charging hazard - see instructions. Substitution of components may impair suitability for hazardous locations.

AVERTISSEMENTS: Risque potentiel de décharges électrostatiques - voir consignes. La substitution de composants peut compromettre l'adaptabilité aux emplacements dangereux.

Factory Sealed / XP conduit seals not required.

A0039225



Field no.	Order code FMP5x-aabcdeffgghh+options				Contents	Comment	
3	-				Made in Germany, 79689 Maulburg	Depending on production plant	
					Assembled in USA		
					Assembled in India		
6	-				+*****#	+options added to Order Code (multiple options may be added; options relevant to approval are included below)	
8	-				Ident.-No.	Individual no. for identically configured devices	
12	-				Actual process temperature	Depends on options ff, gg and hhh	
13	-				Permissible pressure (process): bar or psi	Depends on antenna type FMR6x and process connection (options hhh)	
15	-				Process wetted materials	Depends on options ff, gg and hhh	
21	e = A, B, I, M				M20x1,5 / M16x1,5	Cable Entry	
	e = C				G ½ / M16x1,5		
	e = D				NPT ½ / M16x1,5		
23	aa = FA, FB, FF		b = A		14 to 30 V <sub>DC</sub> / 2-wire	Electrical Ratings depending on IO boards <sup>1)</sup>	
			b = B		16 to 30 V <sub>DC</sub> / 2-wire		
			b = C		16 to 28 V <sub>DC</sub> / 2-wire		
	aa = 8A		b = A, B		16 to 30 V <sub>DC</sub> / 2-wire		
			b = C		16 to 28 V <sub>DC</sub> / 2-wire		
27	b = B				Switch output	2nd channel output	
	b = C				4 to 20 mA		
52	FMR60	aa = FA, FB			+options = NC	Single Seal	Process seal rating
	FMR62	aa = FA, FB, FF	ff = GE, GF	gg = A5, C1	+options = NC	Single Seal (MWP: 16 bar)	
				gg = A6, C2		Single Seal (MWP: 16 bar)	
			ff = GM, GN	gg = F5	+options = NC	Single Seal (MWP: 16 bar)	
				gg = F6		Single Seal (MWP: 16 bar)	
	FMR67	aa = FA, FB	ff = GP	gg = A6		Single Seal	
63, 64	-				(checkbox)	First installation checkbox	

1) In connection with Optional specification, ID Nx (Accessory Mounted) = NF: Add 2 V to low end

---

---



71449327

[www.addresses.endress.com](http://www.addresses.endress.com)

---