

# Safety Instructions

## Micropilot

### FMR60, FMR62, FMR67

4-20 mA HART

Control Drawing XP/DIP



Document: XA01616F-B

Safety instructions for electrical apparatus for explosion-hazardous areas →  3

Document: XA01616F-B

Temperature tables →  15

Document: XA01616F-B

Attachment: Nameplate view →  39



# Micropilot FMR60, FMR62, FMR67

4-20 mA HART

## Table of contents

Associated documentation . . . . .	4
Manufacturer's certificates . . . . .	4
Manufacturer address . . . . .	4
Extended order code . . . . .	4
Combined type of protection (Approval code, 8A) . . . . .	7
Safety instructions: General . . . . .	8
Safety instructions: Special conditions . . . . .	8
Safety instructions: Installation . . . . .	9
Explosionproof / Flameproof . . . . .	10
Class I, Div. 2, Groups A-D . . . . .	11
Process seals . . . . .	11
Temperature tables . . . . .	12
Connection data . . . . .	12

**Associated documentation** This document is an integral part of the following Operating Instructions:

- BA01618F/00 (FMR60)
- BA01619F/00 (FMR62)
- BA01620F/00 (FMR67)

**Manufacturer's certificates** **FM C/US certificate**

Certificate number:

- FM17US0187X
- FM17CA0099X

**Manufacturer address** Endress+Hauser SE+Co. KG  
Hauptstraße 1  
79689 Maulburg, Germany  
Address of the manufacturing plant: See nameplate.

**Extended order code** The extended order code is indicated on the nameplate, which is affixed to the device in such a way that it is clearly visible. Additional information about the nameplate is provided in the associated Operating Instructions.

**Structure of the extended order code**

FMR6x	–	*****	+	A*B*C*D*E*F*G*..
<i>(Device type)</i>		<i>(Basic specifications)</i>		<i>(Optional specifications)</i>

\* = Placeholder

At this position, an option (number or letter) selected from the specification is displayed instead of the placeholders.

*Basic specifications*

The features that are absolutely essential for the device (mandatory features) are specified in the basic specifications. The number of positions depends on the number of features available. The selected option of a feature can consist of several positions.

*Optional specifications*

The optional specifications describe additional features for the device (optional features). The number of positions depends on the number of features available. The features have a 2-digit structure to aid identification (e.g. JA). The first digit (ID) stands for the feature group and consists of a number or a letter (e.g. J = Test, Certificate). The second digit constitutes the value that stands for the feature within the group (e.g. A = 3.1 material (wetted parts), inspection certificate).

More detailed information about the device is provided in the following tables. These tables describe the individual positions and IDs in the extended order code which are relevant to hazardous locations.

**Extended order code: Micropilot**



The following specifications reproduce an extract from the product structure and are used to assign:

- This documentation to the device (using the extended order code on the nameplate).
- The device options cited in the document.

*Device type*

FMR60, FMR62, FMR67

*Basic specifications*

Position 1, 2 (Approval)		
Selected option		Description
FMR6x	FD <sup>1)</sup>	FM XP-IS Cl.I Div.1 Gr.A-D, Zn0/1, DIP-IS Cl.II,III Div.1 Gr.E-G, NI Cl.I Div.2
	8A	FM/CSA IS+XP-IS Cl.I Div.1 Gr.A-D, DIP-IS Cl.II,III Div.1 Gr.E-G
FMR60 FMR67	FC	FM XP-IS Cl.I Div.1 Gr.A-D, AIS Cl.I Div.1 Gr.A-D
FMR62 FMR67	FE <sup>2)</sup>	FM DIP Cl.II,III Div.1 Gr.E-G

- 1) The designation includes additionally in connection with Position 4 (Display, Operation) = L, M, N or the Service interface (CDI): AIS Cl.I,II,III Div.1 Gr.A-G
- 2) The designation includes additionally in connection with Position 4 (Display, Operation) = L, M, N or the Service interface (CDI): AIS Cl.II,III Div.1 Gr.E-G

Position 3 (Power Supply, Output)		
Selected option		Description
FMR6x	A	2-wire, 4-20 mA HART
	B	2-wire, 4-20 mA HART, switch output (PFS)
	C	2-wire, 4-20 mA HART, 4...20 mA

Position 4 (Display, Operation)		
Selected option		Description
FMR6x	A	Without, via communication
	C	SD02, 4-line, push buttons + data backup function
	E	SD03, 4-line, illum., touch control + data backup function
	L	Prepared for display FHX50 + M12 connection
	M	Prepared for display FHX50 + custom connection
	N	Prepared for display FHX50 + NPT1/2"

Position 5 (Housing)		
Selected option		Description
FMR6x	C	GT20 dual compartment, Alu, coated
FMR62 FMR67	B	GT18 dual compartment, 316L

Position 6 (Electrical Connection)		
Selected option		Description
FMR6x	C <sup>1)</sup>	Thread G1/2, IP66/68 NEMA4X/6P
	D	Thread NPT1/2, IP66/68 NEMA4X/6P

1) Only in connection with Position 1, 2 (Approval) = FE

Position 7, 8 (Antenna)		
Selected option		Description
FMR60	GA	Drip-off, PTFE DN50
FMR62	GE	Integrated, PEEK, 3/4"
	GF	Integrated, PEEK, 1-1/2"
	GM	PTFE cladded flush mount DN50
	GN	PTFE cladded flush mount DN80
FMR67	GA	Drip-off, PTFE DN50
	GP	PTFE flush mount DN80

Position 9, 10 (Seal)		
Selected option		Description
FMR60	A3	FKM Viton GLT, -40...80°C/-40...176°F
	A4	FKM Viton GLT, -40...130°C/-40...266°F
	C1 <sup>1)</sup>	FFKM Kalrez, -20...150°C/-4...302°F
	B4 <sup>1)</sup>	EPDM, -40...150°C/-40...302°F
FMR62	A5	FKM Viton GLT, -40...150°C/-40...302°F
	A6	FKM Viton GLT, -40...200°C/-40...392°F
	C1	FFKM Kalrez, -20...150°C/-4...302°F
	C2	FFKM Kalrez, -20...200°C/-4...392°F
	F5	PTFE cladded, -40...150°C/-40...302°F
	F6	PTFE cladded, -40...200°C/-40...392°F
FMR67	A3	FKM Viton GLT, -40...80°C/-40...176°F
	A5	FKM Viton GLT, -40...150°C/-40...302°F
	A6	FKM Viton GLT, -40...200°C/-40...392°F

1) Only in connection with Position 1, 2 (Approval) = FC

Position 11-13 (Process Connection)		
Selected option		Description
FMR60	GGJ	Thread ISO228 G1-1/2, 316L
	RGJ	Thread ANSI MNPT1-1/2, 316L
	XxG	Flange (different sizes), PP
	XxJ	Flange (different sizes), 316L

Position 11-13 (Process Connection)		
Selected option		Description
FMR62	AxK	Flange (different sizes), PTFE>316/316L
	CxK	Flange (different sizes), PTFE>316L
	GxJ	Thread ISO (different sizes), 316L
	KxK	Flange (different sizes), PTFE>316L
	MxK	Slotted-nut (different sizes), PTFE>316L
	RxJ	Thread ANSI (different sizes), 316L
	TxK	Tri-Clamp (different sizes), PTFE>316L
FMR67	AxJ	Flange (different sizes), 316/316L
	CxJ	Flange (different sizes), 316L
	GGJ	Thread ISO228 G1-1/2, 316L
	KxJ	Flange (different sizes), 316L
	RGJ	Thread ANSI MNPT1-1/2, 316L
	XxA	Align. device (different sizes)
	XxG	Flange (different sizes), PP
	XxJ	Flange (different sizes), 316L

Position 14 (Air Purge Connection)		
Selected option		Description
FMR67	A <sup>1)</sup>	W/o
	1 <sup>2)</sup>	G1/4
	2 <sup>2)</sup>	NPT1/4
	3 <sup>1)</sup>	Adapter G1/4
	4 <sup>1)</sup>	Adapter NPT1/4

- 1) Only in connection with Position 7, 8 (Antenna) = GA  
2) Only in connection with Position 7, 8 (Antenna) = GP

#### Optional specifications

ID Nx (Accessory Mounted)		
Selected option		Description
FMR6x	NF <sup>1)</sup>	Bluetooth
FMR60 FMR62	NC	Gas-tight feed through

- 1) Only in connection with Position 4 (Display, Operation) = C, E

#### Combined type of protection (Approval code, 8A)

Devices with approval code "8A" are suitable for installation with explosion protection type of Intrinsic Safety or Explosionproof.

- Before initial commissioning, specify the type of protection.
- It is not permitted to change the type of protection after initial commissioning as this can jeopardize the explosion protection.

For aluminum housings:

Void out the explosion protection that is not used on the nameplate.

For stainless steel housings:

Using a striking tool, mark the explosion protection used, or void out the explosion protection that is not used.

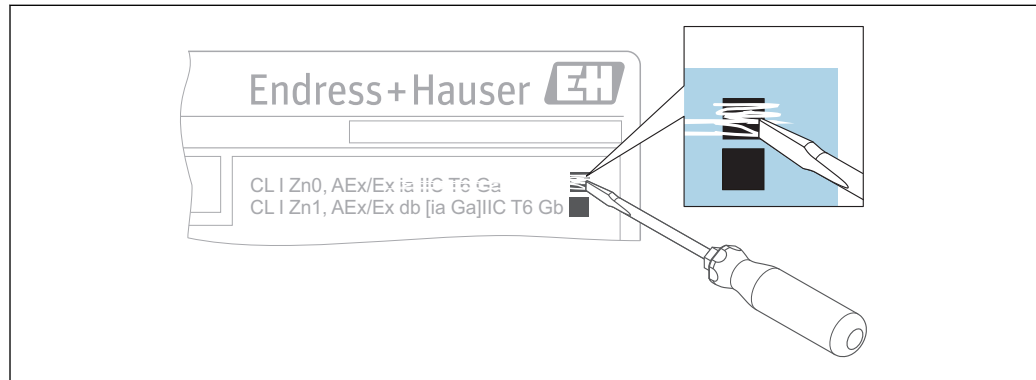

A003253

 1

 It is critical to observe and follow the correct instructions for installation depending on the type of protection used. Refer to the following table for reference to the correct installation instructions.

Type of protection	Agency approval	Control Drawing no. / Document no.
Intrinsic Safety	CSA	XA01612F
	FM	XA01615F
Explosionproof	CSA	XA01613F
	FM	XA01616F

Class I, Division 2 installation:

References in this manual to Class I, Division 2 installation are not applicable for devices with the combined type of protection. For installation in Class I, Division 2, these devices must be installed per the applicable Division 1 intrinsic safety or explosionproof requirements.

#### Safety instructions: General

- Staff must meet the following conditions for mounting, electrical installation, commissioning and maintenance of the device:
  - Be suitably qualified for their role and the tasks they perform
  - Be trained in explosion protection
  - Be familiar with national regulations
- Install the device according to the manufacturer's instructions and national regulations.
- Do not operate the device outside the specified electrical, thermal and mechanical parameters.
- Only use the device in media to which the wetted materials have sufficient durability.
- Avoid electrostatic charging:
  - Of plastic surfaces (e.g. housing, sensor element, special varnishing, attached additional plates, ..)
  - Of isolated capacities (e.g. isolated metallic plates)
- Modifications to the device can affect the explosion protection and must be carried out by staff authorized to perform such work by Endress+Hauser.
- Refer to the temperature tables for the relationship between the permitted ambient temperature for the sensor and/or transmitter, depending on the range of application and the temperature class.

#### Safety instructions: Special conditions

Permitted ambient temperature range at the electronics housing:  
 $-40\text{ °C} \leq T_a \leq +80\text{ °C}$



- Observe the information in the temperature tables.
- Use supply wires suitable for 20 K above the ambient temperature.
- In the event of additional or alternative special varnishing on the housing or other metal parts:
  - Observe the danger of electrostatic charging and discharge.
  - Do not rub surfaces with a dry cloth.

Device type FMR67 and Basic specification, Position 11-13 (Process Connection) = XxA

- Avoid sparks caused by impact and friction.
- Changing the position of the alignment device must be impossible:
  - After the alignment of the antenna via the pivot bracket
  - After tightening of the clamping flange
  - After setting the damping ring (torque 10 to 11 Nm)
- Degree of protection IP67 must be fulfilled.

Device type FMR67 and Basic specification, Position 14 (Air Purge Connection) = 1, 2

- For Class I, II, III, Division 1 and for Class I, Zone 0, Zone 1: In the closed state the minimum degree of protection of the installation must be IP67.
- After removing the air purge connection: Lock the opening with a suitable plug.
  - Torque: 6-7 Nm
  - For Class II and III: thread engagement > 5 turns
- Degree of protection IP67 must be fulfilled.

**Electrostatic/impact sparks**

- In the case of process connections made of polymeric material or with polymeric coatings, avoid electrostatic charging of the plastic surfaces.
- The antennas can be electrostatically charged.

Basic specification, Position 5 (Housing) = C

Avoid sparks caused by impact and friction.

**Safety instructions:  
Installation**

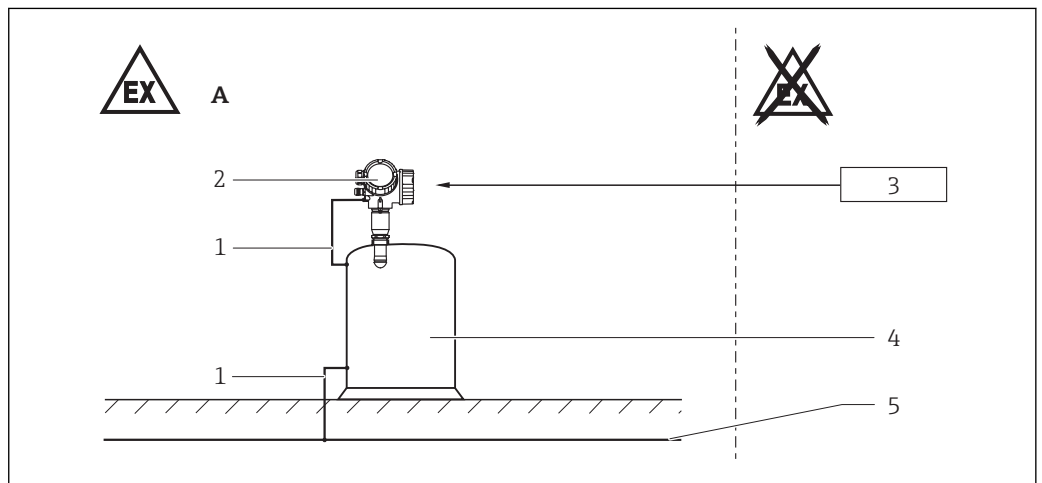

2

- A Class I, Div. 1, Zone 1 or Class I, Div. 2, Groups A, B, C, D;  
Class II, Div. 1, Groups E, F, G;  
Class III
- 1 Potential equalization line
- 2 Electronic insert
- 3 Power supply
- 4 Tank; Zone 0, Zone 1
- 5 Potential equalization

The device can be connected to the Endress+Hauser FXA291 service tool: refer to the Operating Instructions.

 Transmitter provides intrinsically safe circuits for probes.

- After aligning (rotating) the housing, retighten the fixing screw (see Operating Instructions).
- Install the device to exclude any mechanical damage or friction during the application.  
Pay particular attention to flow conditions and tank fittings.
- In potentially explosive atmospheres:
  - Do not disconnect the electrical connection of the power supply circuit when energized.
  - Do not open the connection compartment cover.
- Only use certified cable entries suitable for the application. Observe national regulations and standards. Accordingly, the connection terminal does not include any ignition sources.
- When operating the transmitter housing at an ambient temperature under  $-20\text{ }^{\circ}\text{C}$ , use appropriate cables and cable entries permitted for this application.
- When connecting through a conduit entry approved for this purpose, mount the associated sealing unit directly at the housing.
- Seal unused entry glands with approved sealing plugs that correspond to the type of protection.  
The plastic transport sealing plug does not meet this requirement and must therefore be replaced during installation.
- Before operation:
  - Screw in the cover all the way.
  - Tighten the securing clamp on the cover.
- Continuous service temperature of the connecting cable:  $-40\text{ }^{\circ}\text{C}$  to  $\geq +85\text{ }^{\circ}\text{C}$ ; in accordance with the range of service temperature taking into account additional influences of the process conditions ( $T_{a,\text{min}}$ ), ( $T_{a,\text{max}} + 20\text{ K}$ ).
- The device can be equipped with the Bluetooth® module: refer to the Operating Instructions and specifications in the "Bluetooth® module" chapter.

*Basic specification, Position 4 (Display, Operation) = N*

Observe national regulations and standards for conduit systems.

#### **Bluetooth® module**

*Optional specification, ID Nx (Accessory Mounted) = NF*

- With Bluetooth® module installed: Use of external hardware not allowed (e.g. external display, service interface).
- The intrinsically safe input power circuit of the Bluetooth® module is isolated from ground.

#### **Explosionproof / Flameproof**

Class I, Div. 1, Groups A, B, C, D, Class II, Div. 1, Groups E, F, G, Class III  
Class I, Zone 0/1, AEx ia/db [ia Ga] IIC Ga/Gb / Ex ia/db [ia Ga] IIC Ga/Gb

- Install as per National Electrical Code (NFPA70) or Canadian Electrical Code, Part I (C22.1), as applicable.
- For the maximum supply voltage: See "Connection data" section.
- Control room equipment may not use or generate over  $250\text{ V}_{\text{rms}}$ .
- Seal unused entry glands with approved sealing plugs that correspond to the type of protection.  
The plastic transport sealing plug does not meet this requirement and must therefore be replaced during installation.
- Probe is intrinsically safe, AEx ia/Ex ia, and suitable for installation in Class I, II, III, Division 1 or Class I, Zone 0/1.
- When prepared for use with an approved remote display FHX50, remote display is intrinsically safe suitable for Class I, Division 1/Zone 0 locations and connection between transmitter housing and remote display is intrinsically safe field wiring.
- WARNINGS: Potential electrostatic charging hazard: See instructions.  
Substitution of components may impair suitability for hazardous locations. Keep covers tight when explosive dust atmosphere is present.

Factory sealed

Explosionproof conduit seal not required for terminal compartment.

Terminal compartment

Do not open when explosive atmosphere is present.

Class II and III

- Keep covers tight unless power has been switched off.
- Use a dust-tight seal at the conduit entry in a Class II and III location.

**Class I, Div. 2, Groups A-D**

The following instructions apply only for *Device type FMR6x, Basic specification, Position 1, 2 (Approval) = FD*

*Device type FMR6x, Basic specification, Position 1, 2 (Approval) = FC and 8A* are not marked for use in Class I, Division 2; however, these devices are suitable for this application when installed using the explosionproof instructions for Class I, Division 1.

**Standard Wiring installation (only for NPT conduit entries)**

- Install as per National Electrical Code (NFPA70) or Canadian Electrical Code, Part I (C22.1), as applicable.
- Using wiring methods appropriate for the location.
- For the maximum supply voltage: See "Connection data" section.
- Probe is intrinsically safe, AEx ia/Ex ia, and suitable for installation in Class I, II, III, Division 1 or Class I, Zone 0/1.
- When prepared for use with an approved remote display FHX50, remote display is intrinsically safe suitable for Class I, Division 1/Zone 0 locations and connection between transmitter housing and remote display is intrinsically safe field wiring.
- WARNINGS: Potential electrostatic charging hazard: See instructions.  
Substitution of components may impair suitability for hazardous locations. For Div. 2, do not disconnect equipment unless power has been switched off or area is known to be non-hazardous.

Factory sealed

Explosionproof conduit seal not required for terminal compartment.

**Process seals**

The following device types are Single Seal devices per ANSI/ISA 12.27.01 and do not require the use of an external process seal.

Device type	Basic specification, Position 7, 8 (Antenna)	Basic specification, Position 9, 10 (Seal)	Basic specification, Position 11-13 (Process Connection)	Optional specification, ID Nx (Accessory Mounted)	MWP <sup>1)</sup>
FMR60	xx	B4, C1	xxx	NC	3 bar

1) Maximum Working Pressure for the Single Seal rating.

The following device types require the use of an external process seal where required by the Canadian Electrical Code, Part I or National Electrical Code (as applicable).

Device type	Basic specification, Position 7, 8 (Antenna)	Basic specification, Position 9, 10 (Seal)	Basic specification, Position 11-13 (Process Connection)	Optional specification, ID Nx (Accessory Mounted)	MWP <sup>1)</sup>
FMR60	xx	B4, C1	xxx	-	3 bar

1) Maximum Working Pressure for the Single Seal rating.

The following device types are Dual Seal devices per ANSI/ISA 12.27.01 and do not require the use of an external secondary process seal.

Device type	Basic specification, Position 7, 8 (Antenna)	Basic specification, Position 9, 10 (Seal)	Basic specification, Position 11-13 (Process Connection)	MWP <sup>1)</sup>	Method of annunciation
FMR60	xx	A3, A4	xxx	3 bar	Process fluid leakage through vent located in electronics compartment. When using the remote display FHX50: Leakage may also occur from the vent located in the remote display housing. No maintenance of annunciator necessary.
FMR62	GE	xx	xxx	20 bar	
	GF	xx	xxx	20 bar	
	GM	xx	xxx	25 bar	
	GN	xx	xxx	25 bar	
FMR67	GA	A3	Axx, Cxx, Kxx, Xxx	3 bar	
	GA	A3	GGJ, RGJ	16 bar	
	GP	xx	xxx	16 bar	

1) Maximum Working Pressure for the Dual Seal rating to be effective and may be a value less than the MWP for the device.

 Verify the chemical compatibility of the process seal specified on the nameplate in first position with the process fluid (see field "Mat." on the nameplate).

*Basic specification, Position 4 (Display, Operation) = L M, N and a cable provided by customer, gland M16 or thread NPT1/2*

To prevent possible leakage of process fluids in an area classified as non-hazardous, the FHX50 must be installed in the hazardous location when used with a device with a Dual Seal rating.

Temperature tables

→  16

Connection data

*Optional specification, ID Nx (Accessory Mounted) = NF*

When using the Bluetooth® module: No changes to the connection values.

Connection compartment AEx ia/db / Ex ia/db

*Basic specification, Position 3 (Power Supply, Output) = A*

Terminal 1 (+), 2 (-)
Power supply: $U_N = 35 V_{DC}^{1)}$ $U_m = 250 V$ $I_{max} = 22 mA$

1) Basic specification, Position 1, 2 (Approval) = 8A: 30 V<sub>DC</sub>

*Basic specification, Position 3 (Power Supply, Output) = B*

Terminal 1 (+), 2 (-)	Terminal 3 (+), 4 (-)
Power supply: $U_N = 35 V_{DC}^{1)}$ $U_m = 250 V$ $I_{max} = 22 mA$	Switch output (PFS): $U_N = 35 V_{DC}^{1)}$ $U_m = 250 V$

1) Basic specification, Position 1, 2 (Approval) = 8A: 30 V<sub>DC</sub>

The power consumption of I/O modules with passive PFS output can be limited for certain applications.

- Recommended: Power consumption = 1 W. This is obtained for a supply voltage at the terminals of 27 V<sub>DC</sub>.
- For higher supply voltages (U<sub>max</sub>): Insert a serial resistance (R<sub>V</sub>) in order to limit the power consumption, see table below.

**Table for the PFS serial resistance (R<sub>V</sub>):**

Power consumption	1.0 W
Total power consumption	1.88 W
Internal resistance R <sub>i</sub>	760 Ω

U <sub>max</sub> [V]	R <sub>V</sub> min
35	205 Ω
34	177 Ω
33	150 Ω
32	122 Ω
31	95 Ω
30	67 Ω
29	39 Ω
28	12 Ω
27	0 Ω

 For values associated with a higher or lower internal power consumption please contact Endress+Hauser.

*Basic specification, Position 3 (Power Supply, Output) = C*

Terminal 1 (+), 2 (-)	Terminal 3 (+), 4 (-)
Power supply: U <sub>N</sub> = 30 V <sub>DC</sub> <sup>1)</sup> U <sub>m</sub> = 250 V I <sub>max</sub> = 22 mA	Output 4 to 20 mA: U <sub>N</sub> = 30 V <sub>DC</sub> <sup>1)</sup> U <sub>m</sub> = 250 V I <sub>max</sub> = 22 mA

1) For functional reasons, input may be limited to a reduced supply voltage of 28 V<sub>DC</sub>

**Electronics compartment, intrinsically safe (AEx ia/Ex ia)****Service interface (CDI)**

Taking the following values into consideration, the device can be connected to the certified Endress+Hauser FXA291 service tool or a similar interface:

Service interface														
$U_i = 7.3 \text{ V}$ effective inner inductance $L_i = \text{negligible}$ effective inner capacitance $C_i = \text{negligible}$														
$U_o = 7.3 \text{ V}$ $I_o = 60 \text{ mA}$ $P_o = 110 \text{ mW}$														
$L_o \text{ (mH)} =$	5.00	2.00	1.00	0.50	0.20	0.15	0.10	0.05	0.02	0.01	0.005	0.002	0.001	
$C_o \text{ (}\mu\text{F)}^{1) =}$	0.73	1.20	1.60	2.00	2.60	-	3.20	4.00	5.50	7.30	10.00	12.70	12.70	
$C_o \text{ (}\mu\text{F)}^{2) =}$	-	0.49	0.90	1.40	-	2.00	-	-	-	-	-	-	-	-

1) Values according to PTB "ispark" program

2) Values according to IEC/EN 60079-25, Annex C

**Remote display interface**

- Devices with *Basic specification, Position 4 (Display, Operation) = L, M, N* can be connected to the approved Endress+Hauser remote display FHX50.
- Refer to Safety Instructions XA01095F for additional installation instructions.

# Micropilot FMR60, FMR62, FMR67

4-20 mA HART

## Table of contents

Notes on the structure .....	16
Example diagrams of possible deratings .....	18
Explosionproof AEx/Ex ia/db [ia Ga] IIC .....	19
Standard Div. 2 Wiring .....	28
Class II, III, Div. 1 .....	33

## Notes on the structure

## Extract from the extended order code

## Device type

FMR60, FMR62, FMR67

## Basic specifications

Position 1, 2 (Approval)		
Selected option		Description
FMR6x	FD <sup>1)</sup>	FM XP-IS Cl.I Div.1 Gr.A-D, Zn0/1, DIP-IS Cl.II,III Div.1 Gr.E-G, NI Cl.I Div.2
	8A	FM/CSA IS+XP-IS Cl.I Div.1 Gr.A-D, DIP-IS Cl.II,III Div.1 Gr.E-G
FMR60 FMR67	FC	FM XP-IS Cl.I Div.1 Gr.A-D, AIS Cl.I Div.1 Gr.A-D
FMR62 FMR67	FE <sup>2)</sup>	FM DIP Cl.II,III Div.1 Gr.E-G

1) The designation includes additionally in connection with Position 4 (Display, Operation) = L, M, N or the Service interface (CDI): AIS Cl.I,II,III Div.1 Gr.A-G

2) The designation includes additionally in connection with Position 4 (Display, Operation) = L, M, N or the Service interface (CDI): AIS Cl.II,III Div.1 Gr.E-G

Position 5 (Housing)		
Selected option		Description
FMR6x	C	GT20 dual compartment, Alu, coated
FMR62 FMR67	B	GT18 dual compartment, 316L

Position 7, 8 (Antenna)		
Selected option		Description
FMR60	GA	Drip-off, PTFE DN50
FMR62	GE	Integrated, PEEK, 3/4"
	GF	Integrated, PEEK, 1-1/2"
	GM	PTFE cladded flush mount DN50
	GN	PTFE cladded flush mount DN80
FMR67	GA	Drip-off, PTFE DN50
	GP	PTFE flush mount DN80

Position 9, 10 (Seal)		
Selected option		Description
FMR60	A3	FKM Viton GLT, -40...80°C/-40...176°F
	A4	FKM Viton GLT, -40...130°C/-40...266°F
	C1 <sup>1)</sup>	FFKM Kalrez, -20...150°C/-4...302°F
	B4 <sup>1)</sup>	EPDM, -40...150°C/-40...302°F



Position 9, 10 (Seal)		
Selected option		Description
FMR62	A5	FKM Viton GLT, -40...150°C/-40...302°F
	A6	FKM Viton GLT, -40...200°C/-40...392°F
	C1	FFKM Kalrez, -20...150°C/-4...302°F
	C2	FFKM Kalrez, -20...200°C/-4...392°F
	F5	PTFE cladded, -40...150°C/-40...302°F
	F6	PTFE cladded, -40...200°C/-40...392°F
FMR67	A3	FKM Viton GLT, -40...80°C/-40...176°F
	A5	FKM Viton GLT, -40...150°C/-40...302°F
	A6	FKM Viton GLT, -40...200°C/-40...392°F

1) Only in connection with Position 1, 2 (Approval) = FC

**General notes**

 Observe the permitted temperature range at the antenna.

**Description notes**

 Unless otherwise indicated, the positions always refer to the basic specification.

Class I, Div. 1 or Div. 2

1st column: Temperature classes T6 (85 °C) to T1 (450 °C)

Column P1 to P5: Position (temperature value) on the axes of the derating

- T<sub>a</sub>: Ambient temperature in °C
- T<sub>p</sub>: Process temperature in °C

	P1		P2		P2+		P3		P4		P5	
	T <sub>p</sub>	T <sub>a</sub>	T <sub>p</sub>	T <sub>a</sub>	T <sub>p</sub>	T <sub>a</sub>	T <sub>p</sub>	T <sub>a</sub>	T <sub>p</sub>	T <sub>a</sub>	T <sub>p</sub>	T <sub>a</sub>
T6	-40	51	51	51	-	-	85	45	85	-40	-40	-40
T5	-40	64	64	64	-	-	100	58	100	-40	-40	-40
T4	-40	64	64	64	-	-	135	52	135	-40	-40	-40

A0031752-EN

 Column P2+ is only relevant for version B of the derating.  
→  18

Class II, III, Div. 1

1st column: Process temperature

Column P1 to P5: Position (temperature value) on the axes of the derating

- T<sub>a</sub>: Ambient temperature in °C
- T<sub>p</sub>: Process temperature in °C

	P1		P2		P3		P4		P5	
	T <sub>p</sub>	T <sub>a</sub>	T <sub>p</sub>	T <sub>a</sub>	T <sub>p</sub>	T <sub>a</sub>	T <sub>p</sub>	T <sub>a</sub>	T <sub>p</sub>	T <sub>a</sub>
100	-40	75	75	75	100	58	100	-40	-40	-40
135	-40	75	75	75	135	52	135	-40	-40	-40
150	-40	75	75	75	150	47	150	-40	-40	-40

A0033298-EN

Example diagrams  
of possible deratings

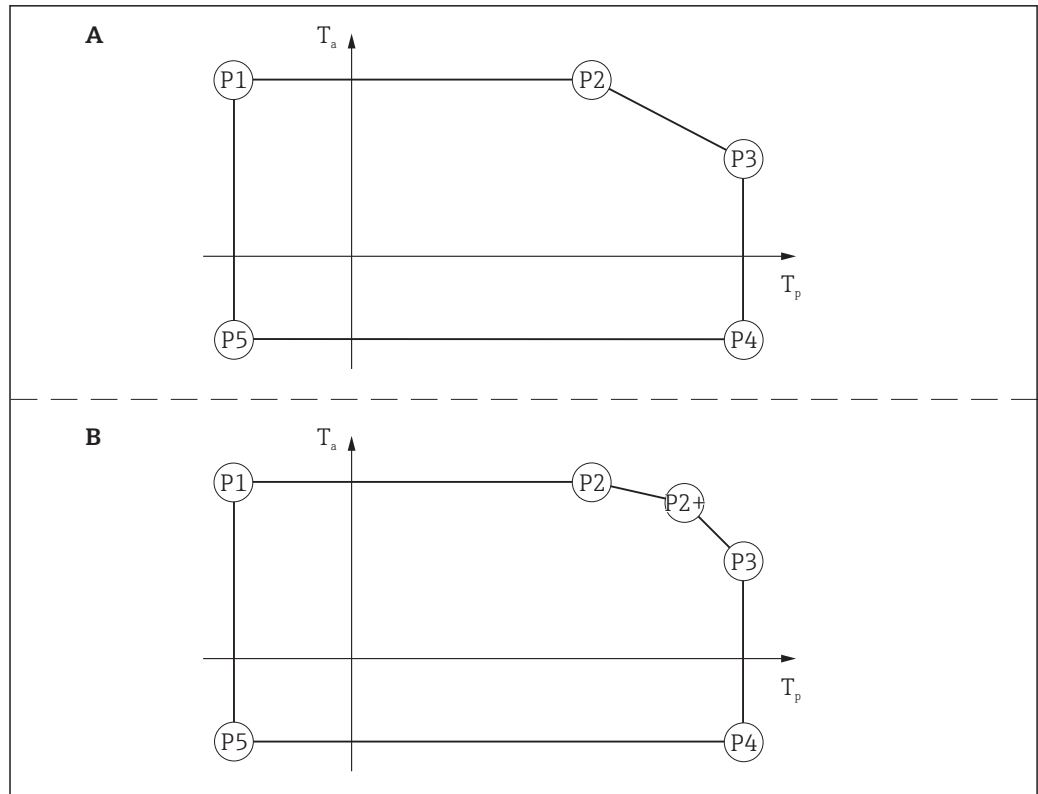

A0031943

3

**Explosionproof  
AEx/Ex ia/db [ia Ga] IIC**

Antenna: Class I, Zone 0 / Class I, Div. 1; Electronics housing: Class I, Zone 1 / Class I, Div. 1

Page references to the temperature tables of the respective device types: See the following list.

- FMR60 → 19
- FMR62 → 21
- FMR67 → 25

**FMR60***Position 7, 8 (Antenna) = GA**Position 9, 10 (Seal) = A3**Position 5 (Housing) = C*

	P1		P2		P2+		P3		P4		P5	
	T <sub>p</sub>	T <sub>a</sub>	T <sub>p</sub>	T <sub>a</sub>	T <sub>p</sub>	T <sub>a</sub>	T <sub>p</sub>	T <sub>a</sub>	T <sub>p</sub>	T <sub>a</sub>	T <sub>p</sub>	T <sub>a</sub>
T6	-40	51	51	51	-	-	80	47	80	-40	-40	-40

**FMR60***Position 7, 8 (Antenna) = GA**Position 9, 10 (Seal) = A4**Position 5 (Housing) = C*

	P1		P2		P2+		P3		P4		P5	
	T <sub>p</sub>	T <sub>a</sub>	T <sub>p</sub>	T <sub>a</sub>	T <sub>p</sub>	T <sub>a</sub>	T <sub>p</sub>	T <sub>a</sub>	T <sub>p</sub>	T <sub>a</sub>	T <sub>p</sub>	T <sub>a</sub>
T6	-40	51	51	51	-	-	85	46	85	-40	-40	-40
T5	-40	64	64	64	-	-	100	59	100	-40	-40	-40
T4	-40	64	64	64	-	-	130	54	130	-40	-40	-40

**FMR60***Position 7, 8 (Antenna) = GA**Position 9, 10 (Seal) = C1**Position 5 (Housing) = C*

	P1		P2		P2+		P3		P4		P5	
	T <sub>p</sub>	T <sub>a</sub>	T <sub>p</sub>	T <sub>a</sub>	T <sub>p</sub>	T <sub>a</sub>	T <sub>p</sub>	T <sub>a</sub>	T <sub>p</sub>	T <sub>a</sub>	T <sub>p</sub>	T <sub>a</sub>
T6	-20	51	51	51	-	-	85	46	85	-20	-20	-20
T5	-20	64	64	64	-	-	100	59	100	-20	-20	-20
T4	-20	64	64	64	-	-	135	54	135	-20	-20	-20
T3	-20	64	64	64	-	-	150	50	150	-20	-20	-20

**FMR60***Position 7, 8 (Antenna) = GA**Position 9, 10 (Seal) = B4**Position 5 (Housing) = C*

	P1		P2		P2+		P3		P4		P5	
	T <sub>p</sub>	T <sub>a</sub>	T <sub>p</sub>	T <sub>a</sub>	T <sub>p</sub>	T <sub>a</sub>	T <sub>p</sub>	T <sub>a</sub>	T <sub>p</sub>	T <sub>a</sub>	T <sub>p</sub>	T <sub>a</sub>
T6	-40	51	51	51	-	-	85	46	85	-40	-40	-40
T5	-40	64	64	64	-	-	100	59	100	-40	-40	-40
T4	-40	64	64	64	-	-	135	54	135	-40	-40	-40
T3	-40	64	64	64	-	-	150	50	150	-40	-40	-40

**FMR62***Position 7, 8 (Antenna) = GE, GF, GM, GN**Position 9, 10 (Seal) = A5, F5**Position 5 (Housing) = B*

	P1		P2		P2+		P3		P4		P5	
	T <sub>p</sub>	T <sub>a</sub>	T <sub>p</sub>	T <sub>a</sub>	T <sub>p</sub>	T <sub>a</sub>	T <sub>p</sub>	T <sub>a</sub>	T <sub>p</sub>	T <sub>a</sub>	T <sub>p</sub>	T <sub>a</sub>
T6	-40	51	51	51	-	-	85	45	85	-40	-40	-40
T5	-40	64	64	64	-	-	100	58	100	-40	-40	-40
T4	-40	64	64	64	-	-	135	52	135	-40	-40	-40
T3	-40	64	64	64	-	-	150	47	150	-40	-40	-40

*Position 5 (Housing) = C*

	P1		P2		P2+		P3		P4		P5	
	T <sub>p</sub>	T <sub>a</sub>	T <sub>p</sub>	T <sub>a</sub>	T <sub>p</sub>	T <sub>a</sub>	T <sub>p</sub>	T <sub>a</sub>	T <sub>p</sub>	T <sub>a</sub>	T <sub>p</sub>	T <sub>a</sub>
T6	-40	51	51	51	-	-	85	47	85	-40	-40	-40
T5	-40	64	64	64	-	-	100	60	100	-40	-40	-40
T4	-40	64	64	64	-	-	135	56	135	-40	-40	-40
T3	-40	64	64	64	-	-	150	54	150	-40	-40	-40

**FMR62***Position 7, 8 (Antenna) = GE, GF, GM, GN**Position 9, 10 (Seal) = A6, F6**Position 5 (Housing) = B, C*

	P1		P2		P2+		P3		P4		P5	
	T <sub>p</sub>	T <sub>a</sub>	T <sub>p</sub>	T <sub>a</sub>	T <sub>p</sub>	T <sub>a</sub>	T <sub>p</sub>	T <sub>a</sub>	T <sub>p</sub>	T <sub>a</sub>	T <sub>p</sub>	T <sub>a</sub>
T6	-40	51	51	51	-	-	85	48	85	-40	-40	-40
T5	-40	64	64	64	-	-	100	61	100	-40	-40	-40
T4	-40	64	64	64	-	-	135	58	135	-40	-40	-40
T3	-40	64	64	64	-	-	200	53	200	-40	-40	-40

**FMR62***Position 7, 8 (Antenna) = GE, GF, GM, GN**Position 9, 10 (Seal) = C1**Position 5 (Housing) = B*

	P1		P2		P2+		P3		P4		P5	
	T <sub>p</sub>	T <sub>a</sub>	T <sub>p</sub>	T <sub>a</sub>	T <sub>p</sub>	T <sub>a</sub>	T <sub>p</sub>	T <sub>a</sub>	T <sub>p</sub>	T <sub>a</sub>	T <sub>p</sub>	T <sub>a</sub>
T6	-20	51	51	51	-	-	85	45	85	-20	-20	-20
T5	-20	64	64	64	-	-	100	58	100	-20	-20	-20
T4	-20	64	64	64	-	-	135	52	135	-20	-20	-20
T3	-20	64	64	64	-	-	150	47	150	-20	-20	-20

*Position 5 (Housing) = C*

	P1		P2		P2+		P3		P4		P5	
	T <sub>p</sub>	T <sub>a</sub>	T <sub>p</sub>	T <sub>a</sub>	T <sub>p</sub>	T <sub>a</sub>	T <sub>p</sub>	T <sub>a</sub>	T <sub>p</sub>	T <sub>a</sub>	T <sub>p</sub>	T <sub>a</sub>
T6	-20	51	51	51	-	-	85	47	85	-20	-20	-20
T5	-20	64	64	64	-	-	100	60	100	-20	-20	-20
T4	-20	64	64	64	-	-	135	56	135	-20	-20	-20
T3	-20	64	64	64	-	-	150	54	150	-20	-20	-20

**FMR62***Position 7, 8 (Antenna) = GE, GF, GM, GN**Position 9, 10 (Seal) = C2**Position 5 (Housing) = B, C*

	P1		P2		P2+		P3		P4		P5	
	T <sub>p</sub>	T <sub>a</sub>	T <sub>p</sub>	T <sub>a</sub>	T <sub>p</sub>	T <sub>a</sub>	T <sub>p</sub>	T <sub>a</sub>	T <sub>p</sub>	T <sub>a</sub>	T <sub>p</sub>	T <sub>a</sub>
T6	-20	51	51	51	-	-	85	48	85	-20	-20	-20
T5	-20	64	64	64	-	-	100	61	100	-20	-20	-20
T4	-20	64	64	64	-	-	135	58	135	-20	-20	-20
T3	-20	64	64	64	-	-	200	53	200	-20	-20	-20



**FMR67**

*Position 7, 8 (Antenna) = GA*

*Position 9, 10 (Seal) = A3*

*Position 5 (Housing) = B*

	P1		P2		P2+		P3		P4		P5	
	T <sub>p</sub>	T <sub>a</sub>	T <sub>p</sub>	T <sub>a</sub>	T <sub>p</sub>	T <sub>a</sub>	T <sub>p</sub>	T <sub>a</sub>	T <sub>p</sub>	T <sub>a</sub>	T <sub>p</sub>	T <sub>a</sub>
T6	-40	51	51	51	-	-	80	43	80	-40	-40	-40

*Position 5 (Housing) = C*

	P1		P2		P2+		P3		P4		P5	
	T <sub>p</sub>	T <sub>a</sub>	T <sub>p</sub>	T <sub>a</sub>	T <sub>p</sub>	T <sub>a</sub>	T <sub>p</sub>	T <sub>a</sub>	T <sub>p</sub>	T <sub>a</sub>	T <sub>p</sub>	T <sub>a</sub>
T6	-40	51	51	51	-	-	80	47	80	-40	-40	-40

**FMR67***Position 7, 8 (Antenna) = GP**Position 9, 10 (Seal) = A5**Position 5 (Housing) = B*

	P1		P2		P2+		P3		P4		P5	
	T <sub>p</sub>	T <sub>a</sub>	T <sub>p</sub>	T <sub>a</sub>	T <sub>p</sub>	T <sub>a</sub>	T <sub>p</sub>	T <sub>a</sub>	T <sub>p</sub>	T <sub>a</sub>	T <sub>p</sub>	T <sub>a</sub>
T6	-40	51	51	51	-	-	85	45	85	-40	-40	-40
T5	-40	64	64	64	-	-	100	58	100	-40	-40	-40
T4	-40	64	64	64	-	-	135	52	135	-40	-40	-40
T3	-40	64	64	64	-	-	150	47	150	-40	-40	-40

*Position 5 (Housing) = C*

	P1		P2		P2+		P3		P4		P5	
	T <sub>p</sub>	T <sub>a</sub>	T <sub>p</sub>	T <sub>a</sub>	T <sub>p</sub>	T <sub>a</sub>	T <sub>p</sub>	T <sub>a</sub>	T <sub>p</sub>	T <sub>a</sub>	T <sub>p</sub>	T <sub>a</sub>
T6	-40	51	51	51	-	-	85	47	85	-40	-40	-40
T5	-40	64	64	64	-	-	100	60	100	-40	-40	-40
T4	-40	64	64	64	-	-	135	56	135	-40	-40	-40
T3	-40	64	64	64	-	-	150	54	150	-40	-40	-40

**FMR67***Position 7, 8 (Antenna) = GP**Position 9, 10 (Seal) = A6**Position 5 (Housing) = B, C*

	P1		P2		P2+		P3		P4		P5	
	T <sub>p</sub>	T <sub>a</sub>	T <sub>p</sub>	T <sub>a</sub>	T <sub>p</sub>	T <sub>a</sub>	T <sub>p</sub>	T <sub>a</sub>	T <sub>p</sub>	T <sub>a</sub>	T <sub>p</sub>	T <sub>a</sub>
T6	-40	51	51	51	-	-	85	48	85	-40	-40	-40
T5	-40	64	64	64	-	-	100	61	100	-40	-40	-40
T4	-40	64	64	64	-	-	135	58	135	-40	-40	-40
T3	-40	64	64	64	-	-	200	53	200	-40	-40	-40

**Standard Div. 2 Wiring**

Antenna: Class I, Zone 0 or Zone 1 / Class I, Div. 1 or Div. 2; Electronics housing: Class I, Div. 2  
 Page references to the temperature tables of the respective device types: See the following list.

- FMR60 → 28
- FMR62 → 30
- FMR67 → 32

**FMR60**

*Position 7, 8 (Antenna) = GA*

*Position 9, 10 (Seal) = A3*

*Position 5 (Housing) = C*

	P1		P2		P2+		P3		P4		P5	
	T <sub>p</sub>	T <sub>a</sub>	T <sub>p</sub>	T <sub>a</sub>	T <sub>p</sub>	T <sub>a</sub>	T <sub>p</sub>	T <sub>a</sub>	T <sub>p</sub>	T <sub>a</sub>	T <sub>p</sub>	T <sub>a</sub>
T6	-40	41	41	41	-	-	80	32	80	-40	-40	-40

**FMR60**

*Position 7, 8 (Antenna) = GA*

*Position 9, 10 (Seal) = A4*

*Position 5 (Housing) = C*

	P1		P2		P2+		P3		P4		P5	
	T <sub>p</sub>	T <sub>a</sub>	T <sub>p</sub>	T <sub>a</sub>	T <sub>p</sub>	T <sub>a</sub>	T <sub>p</sub>	T <sub>a</sub>	T <sub>p</sub>	T <sub>a</sub>	T <sub>p</sub>	T <sub>a</sub>
T6	-40	41	41	41	-	-	85	34	85	-40	-40	-40
T5	-40	56	56	56	-	-	100	49	100	-40	-40	-40
T4	-40	64	64	64	-	-	130	54	130	-40	-40	-40

**FMR60***Position 7, 8 (Antenna) = GA**Position 9, 10 (Seal) = C1**Position 5 (Housing) = C*

	P1		P2		P2+		P3		P4		P5	
	T <sub>p</sub>	T <sub>a</sub>	T <sub>p</sub>	T <sub>a</sub>	T <sub>p</sub>	T <sub>a</sub>	T <sub>p</sub>	T <sub>a</sub>	T <sub>p</sub>	T <sub>a</sub>	T <sub>p</sub>	T <sub>a</sub>
T6	-20	41	41	41	-	-	85	34	85	-20	-20	-20
T5	-20	56	56	56	-	-	100	49	100	-20	-20	-20
T4	-20	64	64	64	-	-	135	54	135	-20	-20	-20
T3	-20	64	64	64	-	-	150	50	150	-20	-20	-20

**FMR60***Position 7, 8 (Antenna) = GA**Position 9, 10 (Seal) = B4**Position 5 (Housing) = C*

	P1		P2		P2+		P3		P4		P5	
	T <sub>p</sub>	T <sub>a</sub>	T <sub>p</sub>	T <sub>a</sub>	T <sub>p</sub>	T <sub>a</sub>	T <sub>p</sub>	T <sub>a</sub>	T <sub>p</sub>	T <sub>a</sub>	T <sub>p</sub>	T <sub>a</sub>
T6	-40	41	41	41	-	-	85	34	85	-40	-40	-40
T5	-40	56	56	56	-	-	100	49	100	-40	-40	-40
T4	-40	64	64	64	-	-	135	54	135	-40	-40	-40
T3	-40	64	64	64	-	-	150	50	150	-40	-40	-40

**FMR62***Position 7, 8 (Antenna) = GE, GF, GM, GN**Position 9, 10 (Seal) = A5, F5**Position 5 (Housing) = B*

	P1		P2		P2+		P3		P4		P5	
	T <sub>p</sub>	T <sub>a</sub>	T <sub>p</sub>	T <sub>a</sub>	T <sub>p</sub>	T <sub>a</sub>	T <sub>p</sub>	T <sub>a</sub>	T <sub>p</sub>	T <sub>a</sub>	T <sub>p</sub>	T <sub>a</sub>
T6	-40	41	41	41	-	-	85	33	85	-40	-40	-40
T5	-40	56	56	56	-	-	100	48	100	-40	-40	-40
T4	-40	64	64	64	-	-	135	52	135	-40	-40	-40
T3	-40	64	64	64	-	-	150	47	150	-40	-40	-40

*Position 5 (Housing) = C*

	P1		P2		P2+		P3		P4		P5	
	T <sub>p</sub>	T <sub>a</sub>	T <sub>p</sub>	T <sub>a</sub>	T <sub>p</sub>	T <sub>a</sub>	T <sub>p</sub>	T <sub>a</sub>	T <sub>p</sub>	T <sub>a</sub>	T <sub>p</sub>	T <sub>a</sub>
T6	-40	41	41	41	-	-	85	36	85	-40	-40	-40
T5	-40	56	56	56	-	-	100	51	100	-40	-40	-40
T4	-40	64	64	64	-	-	135	56	135	-40	-40	-40
T3	-40	64	64	64	-	-	150	54	150	-40	-40	-40

**FMR62***Position 7, 8 (Antenna) = GE, GF, GM, GN**Position 9, 10 (Seal) = A6, F6**Position 5 (Housing) = B, C*

	P1		P2		P2+		P3		P4		P5	
	T <sub>p</sub>	T <sub>a</sub>	T <sub>p</sub>	T <sub>a</sub>	T <sub>p</sub>	T <sub>a</sub>	T <sub>p</sub>	T <sub>a</sub>	T <sub>p</sub>	T <sub>a</sub>	T <sub>p</sub>	T <sub>a</sub>
T6	-40	41	41	41	-	-	85	37	85	-40	-40	-40
T5	-40	56	56	56	-	-	100	52	100	-40	-40	-40
T4	-40	64	64	64	-	-	135	58	135	-40	-40	-40
T3	-40	64	64	64	-	-	200	53	200	-40	-40	-40

**FMR62***Position 7, 8 (Antenna) = GE, GF, GM, GN**Position 9, 10 (Seal) = C1**Position 5 (Housing) = B*

	P1		P2		P2+		P3		P4		P5	
	T <sub>p</sub>	T <sub>a</sub>	T <sub>p</sub>	T <sub>a</sub>	T <sub>p</sub>	T <sub>a</sub>	T <sub>p</sub>	T <sub>a</sub>	T <sub>p</sub>	T <sub>a</sub>	T <sub>p</sub>	T <sub>a</sub>
T6	-20	41	41	41	-	-	85	33	85	-20	-20	-20
T5	-20	56	56	56	-	-	100	48	100	-20	-20	-20
T4	-20	64	64	64	-	-	135	52	135	-20	-20	-20
T3	-20	64	64	64	-	-	150	47	150	-20	-20	-20

*Position 5 (Housing) = C*

	P1		P2		P2+		P3		P4		P5	
	T <sub>p</sub>	T <sub>a</sub>	T <sub>p</sub>	T <sub>a</sub>	T <sub>p</sub>	T <sub>a</sub>	T <sub>p</sub>	T <sub>a</sub>	T <sub>p</sub>	T <sub>a</sub>	T <sub>p</sub>	T <sub>a</sub>
T6	-20	41	41	41	-	-	85	36	85	-20	-20	-20
T5	-20	56	56	56	-	-	100	51	100	-20	-20	-20
T4	-20	64	64	64	-	-	135	56	135	-20	-20	-20
T3	-20	64	64	64	-	-	150	54	150	-20	-20	-20

**FMR62***Position 7, 8 (Antenna) = GE, GF, GM, GN**Position 9, 10 (Seal) = C2**Position 5 (Housing) = B, C*

	P1		P2		P2+		P3		P4		P5	
	T <sub>p</sub>	T <sub>a</sub>	T <sub>p</sub>	T <sub>a</sub>	T <sub>p</sub>	T <sub>a</sub>	T <sub>p</sub>	T <sub>a</sub>	T <sub>p</sub>	T <sub>a</sub>	T <sub>p</sub>	T <sub>a</sub>
T6	-20	41	41	41	-	-	85	37	85	-20	-20	-20
T5	-20	56	56	56	-	-	100	52	100	-20	-20	-20
T4	-20	64	64	64	-	-	135	58	135	-20	-20	-20
T3	-20	64	64	64	-	-	200	53	200	-20	-20	-20

**FMR67***Position 7, 8 (Antenna) = GA**Position 9, 10 (Seal) = A3**Position 5 (Housing) = B, C*

	P1		P2		P2+		P3		P4		P5	
	T <sub>p</sub>	T <sub>a</sub>	T <sub>p</sub>	T <sub>a</sub>	T <sub>p</sub>	T <sub>a</sub>	T <sub>p</sub>	T <sub>a</sub>	T <sub>p</sub>	T <sub>a</sub>	T <sub>p</sub>	T <sub>a</sub>
T6	-40	41	41	41	-	-	80	32	80	-40	-40	-40

**FMR67***Position 7, 8 (Antenna) = GP**Position 9, 10 (Seal) = A5**Position 5 (Housing) = B*

	P1		P2		P2+		P3		P4		P5	
	T <sub>p</sub>	T <sub>a</sub>	T <sub>p</sub>	T <sub>a</sub>	T <sub>p</sub>	T <sub>a</sub>	T <sub>p</sub>	T <sub>a</sub>	T <sub>p</sub>	T <sub>a</sub>	T <sub>p</sub>	T <sub>a</sub>
T6	-40	41	41	41	-	-	85	33	85	-40	-40	-40
T5	-40	56	56	56	-	-	100	48	100	-40	-40	-40
T4	-40	64	64	64	-	-	135	52	135	-40	-40	-40
T3	-40	64	64	64	-	-	150	47	150	-40	-40	-40

*Position 5 (Housing) = C*

	P1		P2		P2+		P3		P4		P5	
	T <sub>p</sub>	T <sub>a</sub>	T <sub>p</sub>	T <sub>a</sub>	T <sub>p</sub>	T <sub>a</sub>	T <sub>p</sub>	T <sub>a</sub>	T <sub>p</sub>	T <sub>a</sub>	T <sub>p</sub>	T <sub>a</sub>
T6	-40	41	41	41	-	-	85	36	85	-40	-40	-40
T5	-40	56	56	56	-	-	100	51	100	-40	-40	-40
T4	-40	64	64	64	-	-	135	56	135	-40	-40	-40
T3	-40	64	64	64	-	-	150	54	150	-40	-40	-40

**FMR67***Position 7, 8 (Antenna) = GP**Position 9, 10 (Seal) = A6**Position 5 (Housing) = B, C*

	P1		P2		P2+		P3		P4		P5	
	T <sub>p</sub>	T <sub>a</sub>	T <sub>p</sub>	T <sub>a</sub>	T <sub>p</sub>	T <sub>a</sub>	T <sub>p</sub>	T <sub>a</sub>	T <sub>p</sub>	T <sub>a</sub>	T <sub>p</sub>	T <sub>a</sub>
T6	-40	41	41	41	-	-	85	37	85	-40	-40	-40
T5	-40	56	56	56	-	-	100	52	100	-40	-40	-40
T4	-40	64	64	64	-	-	135	58	135	-40	-40	-40
T3	-40	64	64	64	-	-	200	53	200	-40	-40	-40



**Class II, III, Div. 1**

Antenna and electronics housing: Class II, III, Div. 1

Page references to the temperature tables of the respective device types: See the following list.

- FMR60 → 33
- FMR62 → 35
- FMR67 → 37

**FMR60***Position 7, 8 (Antenna) = GA**Position 9, 10 (Seal) = A3**Position 5 (Housing) = C*

	P1		P2		P3		P4		P5	
	T <sub>p</sub>	T <sub>a</sub>	T <sub>p</sub>	T <sub>a</sub>	T <sub>p</sub>	T <sub>a</sub>	T <sub>p</sub>	T <sub>a</sub>	T <sub>p</sub>	T <sub>a</sub>
75	-40	75	75	75	75	75	75	-40	-40	-40

**FMR60***Position 7, 8 (Antenna) = GA**Position 9, 10 (Seal) = A4**Position 5 (Housing) = C*

	P1		P2		P3		P4		P5	
	T <sub>p</sub>	T <sub>a</sub>	T <sub>p</sub>	T <sub>a</sub>	T <sub>p</sub>	T <sub>a</sub>	T <sub>p</sub>	T <sub>a</sub>	T <sub>p</sub>	T <sub>a</sub>
100	-40	75	75	75	100	59	100	-40	-40	-40
130	-40	75	75	75	130	54	130	-40	-40	-40

**FMR60***Position 7, 8 (Antenna) = GA**Position 9, 10 (Seal) = C1**Position 5 (Housing) = C*

	P1		P2		P3		P4		P5	
	T <sub>p</sub>	T <sub>a</sub>	T <sub>p</sub>	T <sub>a</sub>	T <sub>p</sub>	T <sub>a</sub>	T <sub>p</sub>	T <sub>a</sub>	T <sub>p</sub>	T <sub>a</sub>
100	-20	75	75	75	100	59	100	-20	-20	-20
135	-20	75	75	75	135	54	135	-20	-20	-20
150	-20	75	75	75	150	50	150	-20	-20	-20

**FMR60***Position 7, 8 (Antenna) = GA**Position 9, 10 (Seal) = B4**Position 5 (Housing) = C*

	P1		P2		P3		P4		P5	
	T <sub>p</sub>	T <sub>a</sub>	T <sub>p</sub>	T <sub>a</sub>	T <sub>p</sub>	T <sub>a</sub>	T <sub>p</sub>	T <sub>a</sub>	T <sub>p</sub>	T <sub>a</sub>
100	-40	75	75	75	100	59	100	-40	-40	-40
135	-40	75	75	75	135	54	135	-40	-40	-40
150	-40	75	75	75	150	50	150	-40	-40	-40

**FMR62**

Position 7, 8 (Antenna) = GE, GF, GM, GN

Position 9, 10 (Seal) = A5, F5

Position 5 (Housing) = B

	P1		P2		P3		P4		P5	
	T <sub>p</sub>	T <sub>a</sub>	T <sub>p</sub>	T <sub>a</sub>	T <sub>p</sub>	T <sub>a</sub>	T <sub>p</sub>	T <sub>a</sub>	T <sub>p</sub>	T <sub>a</sub>
100	-40	75	75	75	100	58	100	-40	-40	-40
135	-40	75	75	75	135	52	135	-40	-40	-40
150	-40	75	75	75	150	47	150	-40	-40	-40

Position 5 (Housing) = C

	P1		P2		P3		P4		P5	
	T <sub>p</sub>	T <sub>a</sub>	T <sub>p</sub>	T <sub>a</sub>	T <sub>p</sub>	T <sub>a</sub>	T <sub>p</sub>	T <sub>a</sub>	T <sub>p</sub>	T <sub>a</sub>
100	-40	75	75	75	100	60	100	-40	-40	-40
135	-40	75	75	75	135	56	135	-40	-40	-40
150	-40	75	75	75	150	54	150	-40	-40	-40

**FMR62**

Position 7, 8 (Antenna) = GE, GF, GM, GN

Position 9, 10 (Seal) = A6, F6

Position 5 (Housing) = B, C

	P1		P2		P3		P4		P5	
	T <sub>p</sub>	T <sub>a</sub>	T <sub>p</sub>	T <sub>a</sub>	T <sub>p</sub>	T <sub>a</sub>	T <sub>p</sub>	T <sub>a</sub>	T <sub>p</sub>	T <sub>a</sub>
100	-40	75	75	75	100	61	100	-40	-40	-40
135	-40	75	75	75	135	58	135	-40	-40	-40
200	-40	75	75	75	200	53	200	-40	-40	-40

**FMR62***Position 7, 8 (Antenna) = GE, GF, GM, GN**Position 9, 10 (Seal) = C1**Position 5 (Housing) = B*

	P1		P2		P3		P4		P5	
	T <sub>p</sub>	T <sub>a</sub>	T <sub>p</sub>	T <sub>a</sub>	T <sub>p</sub>	T <sub>a</sub>	T <sub>p</sub>	T <sub>a</sub>	T <sub>p</sub>	T <sub>a</sub>
100	-20	75	75	75	100	58	100	-20	-20	-20
135	-20	75	75	75	135	52	135	-20	-20	-20
150	-20	75	75	75	150	47	150	-20	-20	-20

*Position 5 (Housing) = C*

	P1		P2		P3		P4		P5	
	T <sub>p</sub>	T <sub>a</sub>	T <sub>p</sub>	T <sub>a</sub>	T <sub>p</sub>	T <sub>a</sub>	T <sub>p</sub>	T <sub>a</sub>	T <sub>p</sub>	T <sub>a</sub>
100	-20	75	75	75	100	60	100	-20	-20	-20
135	-20	75	75	75	135	56	135	-20	-20	-20
150	-20	75	75	75	150	54	150	-20	-20	-20

**FMR62***Position 7, 8 (Antenna) = GE, GF, GM, GN**Position 9, 10 (Seal) = C2**Position 5 (Housing) = B, C*

	P1		P2		P3		P4		P5	
	T <sub>p</sub>	T <sub>a</sub>	T <sub>p</sub>	T <sub>a</sub>	T <sub>p</sub>	T <sub>a</sub>	T <sub>p</sub>	T <sub>a</sub>	T <sub>p</sub>	T <sub>a</sub>
100	-20	75	75	75	100	61	100	-20	-20	-20
135	-20	75	75	75	135	58	135	-20	-20	-20
200	-20	75	75	75	200	53	200	-20	-20	-20

**FMR67**

Position 7, 8 (Antenna) = GA

Position 9, 10 (Seal) = A3

Position 5 (Housing) = B, C

	P1		P2		P3		P4		P5	
	T <sub>p</sub>	T <sub>a</sub>	T <sub>p</sub>	T <sub>a</sub>	T <sub>p</sub>	T <sub>a</sub>	T <sub>p</sub>	T <sub>a</sub>	T <sub>p</sub>	T <sub>a</sub>
75	-40	75	75	75	75	75	75	-40	-40	-40

**FMR67**

Position 7, 8 (Antenna) = GP

Position 9, 10 (Seal) = A5

Position 5 (Housing) = B

	P1		P2		P3		P4		P5	
	T <sub>p</sub>	T <sub>a</sub>	T <sub>p</sub>	T <sub>a</sub>	T <sub>p</sub>	T <sub>a</sub>	T <sub>p</sub>	T <sub>a</sub>	T <sub>p</sub>	T <sub>a</sub>
100	-40	75	75	75	100	58	100	-40	-40	-40
135	-40	75	75	75	135	52	135	-40	-40	-40
150	-40	75	75	75	150	47	150	-40	-40	-40

Position 5 (Housing) = C

	P1		P2		P3		P4		P5	
	T <sub>p</sub>	T <sub>a</sub>	T <sub>p</sub>	T <sub>a</sub>	T <sub>p</sub>	T <sub>a</sub>	T <sub>p</sub>	T <sub>a</sub>	T <sub>p</sub>	T <sub>a</sub>
100	-40	75	75	75	100	60	100	-40	-40	-40
135	-40	75	75	75	135	56	135	-40	-40	-40
150	-40	75	75	75	150	54	150	-40	-40	-40

**FMR67**

Position 7, 8 (Antenna) = GP

Position 9, 10 (Seal) = A6

Position 5 (Housing) = B, C

	P1		P2		P3		P4		P5	
	T <sub>p</sub>	T <sub>a</sub>	T <sub>p</sub>	T <sub>a</sub>	T <sub>p</sub>	T <sub>a</sub>	T <sub>p</sub>	T <sub>a</sub>	T <sub>p</sub>	T <sub>a</sub>
100	-40	75	75	75	100	61	100	-40	-40	-40
135	-40	75	75	75	135	58	135	-40	-40	-40
200	-40	75	75	75	200	53	200	-40	-40	-40



# Micropilot FMR60, FMR62, FMR67

4-20 mA HART

## Table of contents

Attachment: Nameplate view .....	40
----------------------------------	----

Attachment: Nameplate view

**3**

**Micropilot**

Order code:

Ser. no.: xxxxxxxx

Ext. ord. cd.: FMR6x-FCbcdeffgghhh

**6**

⊖

⊕

4...20 mA HART

TP max =  MWP:

Ln =

Ta: -40...+80°C Ta > 60 °C:  $T_{zTa} + 20 K$

Mat.:

Date: JJJJ-MM

**Endress+Hauser**

IP68/66 Type 4X / 6P Encl.

XP-IS CL I, DIV 1, GP A-D, T6...T1  
AIS CL I, DIV 1, GP A-D, [Exia]

See warning sign fixed to the enclosure.  
Voir plaque d'avertissement fixée au boîtier.

For type of protection Ex db: A SEAL SHALL BE INSTALLED WITHIN 50 mm OF THE ENCLOSURE. Pour mode de protection Ex db : UN SCÈLLEMENT DOIT ÊTRE INSTALLÉ À MOINS DE 50 mm DU BOÎTIER.

Factory Sealed / XP conduit seals not required.

XA01616F   
FM17.US0187X, FM17.CA0099X

X = if modification see sep. label Patents →

WARNINGS: Potential electrostatic charging hazard - see instructions.

AVERTISSEMENTS: Risque potentiel de décharges électrostatiques - voir consignes.

**3**

**Micropilot**

Order code:

Ser. no.: xxxxxxxx

Ext. ord. cd.: FMR6x-FDbcdeffgghhh

**6**

⊖

⊕

4...20 mA HART

TP max =  MWP:

Ln =

Ta: -40...+80°C Ta > 60 °C:  $T_{zTa} + 20 K$

Mat.:

Date: JJJJ-MM

**Endress+Hauser**

IP68/66 Type 4X / 6P Encl.

XP-IS CL I, DIV 1, GP A-D, T6...T1 Cl I Zn01  
AEEx iaDb [a Ga] IIC T6...T1 Ga/Gb  
DIP-IS CL II, III, DIV 1, GP E-G N CL I, DIV 2,  
GP A-D, T6...T1 AIS CL I, II, III, DIV 1, GP A-G, [Exia]

See warning sign fixed to the enclosure.  
Voir plaque d'avertissement fixée au boîtier.

For type of protection Ex db: A SEAL SHALL BE INSTALLED WITHIN 50 mm OF THE ENCLOSURE. Pour mode de protection Ex db : UN SCÈLLEMENT DOIT ÊTRE INSTALLÉ À MOINS DE 50 mm DU BOÎTIER.

Factory Sealed / XP conduit seals not required.

XA01616F   
FM17.US0187X, FM17.CA0099X

X = if modification see sep. label Patents →

WARNINGS: Potential electrostatic charging hazard - see instructions. Substitution of components may impair suitability for hazardous locations. For Div. 2, do not disconnect equipment unless power has been switched off or area is known to be non-hazardous.

AVERTISSEMENTS: Risque potentiel de décharges électrostatiques - voir consignes. La substitution de composants peut compromettre l'adaptabilité aux emplacements dangereux. Pour Div. 2, débrancher l'appareil uniquement après avoir coupé l'alimentation électrique ou avoir vérifié qu'il ne soit pas installé en zone dangereuse.

**3**

**Micropilot**

Order code:

Ser. no.: xxxxxxxx

Ext. ord. cd.: FMR6x-FEbcdeffgghhh

**6**

⊖

⊕

4...20 mA HART

TP max =  MWP:

Ln =

Ta: -40...+80°C Ta > 60 °C:  $T_{zTa} + 20 K$

Mat.:

Date: JJJJ-MM

**Endress+Hauser**

IP68/66 Type 4X / 6P Encl.

DIP Cl II, III, DIV 1, GP E-G  
AIS CL II, III, DIV 1, GP E-G, [Exia]

See warning sign fixed to the enclosure.  
Voir plaque d'avertissement fixée au boîtier.

Factory Sealed / XP conduit seals not required.

XA01616F   
FM17.US0187X, FM17.CA0099X

X = if modification see sep. label Patents →

WARNINGS: Potential electrostatic charging hazard - see instructions. Keep covers tight when explosive dust atmosphere is present.

AVERTISSEMENTS: Risque potentiel de décharges électrostatiques - voir consignes. Garder les couvercles bien fermés en présence d'une atmosphère poussiéreuse explosive.

**3**

**Micropilot**

Order code:

Ser. no.: xxxxxxxx

Ext. ord. cd.: FMR6x-8Abcdeffgghhh

**6**

⊖

⊕

4...20 mA HART

TP max =  MWP:

Ln =

Ta: -40...+80°C Ta > 60 °C:  $T_{zTa} + 20 K$

Mat.:

Date: JJJJ-MM

**Endress+Hauser**

IP68/66 Type 4X / 6P Encl.

CRN OF 19773.5C  
151079 CSA 17 70137829

IS CL I, II, III, DIV 1, GP A-G T6...T1  
XP-IS CL I, DIV 1, GP A-D T6...T1  
DIP-IS CL II, III, DIV 1, GP E-G T6...T1  
AIS CL I, II, III, DIV 1, GP A-G [Exia]

See warning sign fixed to the enclosure.  
Voir plaque d'avertissement fixée au boîtier.

FM17.US0187X, FM17.CA0099X

Dual Seal  
XA01613F XA01612F  
XA01616F XA01615F

X = if modification see sep. label Patents →

WARNINGS: Potential electrostatic charging hazard - see instructions. Substitution of components may impair suitability for hazardous locations.

AVERTISSEMENTS: Risque potentiel de décharges électrostatiques - voir consignes. La substitution de composants peut compromettre l'adaptabilité aux emplacements dangereux.

Factory Sealed / XP conduit seals not required.

A0039228



Field no.	Order code FMP5x-aabcdeffgghh+options			Contents	Comment
3	-			Made in Germany, 79689 Maulburg	Depending on production plant
				Assembled in USA	
				Assembled in India	
6	-			+#****#	<b>+options</b> added to Order Code (multiple options may be added; options relevant to approval are included below)
8	-			Ident.-No.	Individual no. for identically configured devices
12	-			Actual process temperature	Depends on options ff, gg and hhh
13	-			Permissible pressure (process): bar or psi	Depends on antenna type FMR6x and process connection (options hhh)
15	-			Process wetted materials	Depends on options ff, gg and hhh
21	aa = FC, FD, 8A	e = D	NPT ½ / M16x1,5		Cable Entry
	aa = FE	e = C	G ½ / M16x1,5		
23	aa = FC, FD, FE	b = A, B	16 to 35 V <sub>DC</sub> / 2-wire		Electrical Ratings depending on IO boards <sup>1)</sup>
		b = C	16 to 28 V <sub>DC</sub> / 2-wire		
	aa = 8A	b = A, B	16 to 30 V <sub>DC</sub> / 2-wire		
		b = C	16 to 28 V <sub>DC</sub> / 2-wire		
27	b = B			Switch output	2nd channel output
	b = C			4 to 20 mA	
152	FMR60	aa = FC	gg = B4, C1	+options = NC	Single Seal
		aa = FC, FD	gg = A3, A4		Dual Seal
	FMR62	aa = FD, FE			Dual Seal
	FMR67	aa = FC, FD, FE			Dual Seal
63, 64	-			(checkbox)	First installation checkbox

1) In connection with Optional specification, ID Nx (Accessory Mounted) = NF: Add 2 V to low end



---



71449328

[www.addresses.endress.com](http://www.addresses.endress.com)

---