

Technical Information

Proline t-mass A 150

Thermal mass flowmeter



Flowmeter for cost-effective measurement and easy monitoring of utility gases

Application

- Measuring principle is characterized by a high operable flow range and direct mass flow measurement
- Suitable for air, nitrogen, carbon dioxide and argon in small line sizes

Device properties

- Inline version: nominal diameter DN 15 to 50 (½ to 2")
- Process pressure up to PN 40, Class 300
- A variety of process connections available
- Device in compact version with DC 24 V power supply
- 4-20 mA HART, pulse/frequency/switch output
- Compact and robust transmitter

Your benefits

- Optimal process monitoring – easy measurement even at low pressures and flow velocities
- Cost-effective measurement – easy installation, negligible pressure loss and maintenance-free
- Reliable flow trending – multivariable measurement
- Fast and efficient commissioning – guided operating menus
- High plant availability – self-diagnostics and error monitoring
- Automatic recovery of data for servicing





Table of contents

Document information	3	System pressure	20
Document conventions	3	Thermal insulation	20
Function and system design	4	Mechanical construction	20
Measuring principle	4	Design, dimensions	20
Measuring system	4	Weight	25
Characteristic values	5	Materials	26
Measured variable	5	Process connections	27
Measuring range	5	Operability	27
Operable flow range	6	Operating concept	27
Output	6	Local operation	28
Output signal	6	Remote operation	28
Signal on alarm	7	Languages	29
Low flow cut off	8	Certificates and approvals	29
Galvanic isolation	8	CE mark	29
Protocol-specific data	8	C-Tick symbol	29
Power supply	9	Ex approval	29
Terminal assignment	9	Pressure Equipment Directive	29
Power consumption	9	Other standards and guidelines	30
Current consumption	10	Ordering information	30
Power supply failure	10	Application packages	30
Electrical connection	10	Accessories	30
Potential equalization	11	Device-specific accessories	30
Terminals	11	Communication-specific accessories	31
Cable entries	11	Service-specific accessories	31
Cable specification	12	System components	32
Performance characteristics	12	Documentation	32
Reference operating conditions	12	Standard documentation	32
Maximum measured error	12	Supplementary device-dependent documentation	32
Repeatability	13	Registered trademarks	32
Response time	13		
Influence of medium pressure	13		
Installation	13		
Mounting location	13		
Orientation	13		
Requirement for pipework	14		
Inlet and outlet runs	15		
Environment	17		
Ambient temperature range	17		
Storage temperature	17		
Degree of protection	17		
Shock resistance	17		
Vibration resistance	17		
Electromagnetic compatibility (EMC)	17		
Process	17		
Medium temperature range	17		
Pressure-temperature ratings	17		
Flow limit	19		
Pressure loss	19		





Document information

Document conventions





Electrical symbols



Symbol	Meaning
 A0011197	Direct current A terminal to which DC voltage is applied or through which direct current flows.
 A0011198	Alternating current A terminal to which alternating voltage (sine-wave) is applied or through which alternating current flows.
 A0011200	Ground connection A grounded terminal which, as far as the operator is concerned, is grounded via a grounding system.
 A0011199	Protective ground connection A terminal which must be connected to ground prior to establishing any other connections.
 A0011201	Equipotential connection A connection that has to be connected to the plant grounding system: This may be a potential equalization line or a star grounding system depending on national or company codes of practice.

Tool symbols



Symbol	Meaning
 A0013442	Torx screwdriver
 A0011220	Flat blade screwdriver
 A0011219	Phillips head screwdriver
 A0011221	Allen key
 A0011222	Hexagon wrench

Symbols for certain types of information

Symbol	Meaning
 A0011182	Allowed Indicates procedures, processes or actions that are allowed.
 A0011183	Preferred Indicates procedures, processes or actions that are preferred.
 A0011184	Forbidden Indicates procedures, processes or actions that are forbidden.
 A0011193	Tip Indicates additional information.
 A0011194	Reference to documentation Refers to the corresponding device documentation.

Symbol	Meaning
 A0011195	Reference to page Refers to the corresponding page number.
 A0011196	Reference to graphic Refers to the corresponding graphic number and page number.

Symbols in graphics

Symbol	Meaning
1, 2, 3,...	Item numbers
1., 2., 3. ...	Series of steps
A, B, C, ...	Views
A-A, B-B, C-C, ...	Sections
 A0013441	Flow direction
 A0011187	Hazardous area Indicates a hazardous area.
 A0011188	Safe area (non-hazardous area) Indicates a non-hazardous location.

Function and system design

Measuring principle

The thermal measuring principle is based on the cooling of a heated resistance thermometer (PT100), from which heat is extracted by the passing gas. The gas passes two PT100 resistance thermometers in the measurement section. One of these is used in the conventional way as a temperature probe, while the other serves as a heating element. The temperature probe monitors and records the effective process temperature while the heated resistance thermometer is kept at a constant differential temperature (compared to the measured gas temperature) by controlling the electrical current used by the heating element. The greater the mass current passing over the heated resistance thermometer, the greater the extent to which cooling takes place and therefore the stronger the current required to maintain a constant differential temperature. This means that the heat current measured is an indicator of the mass flow rate of the gas.

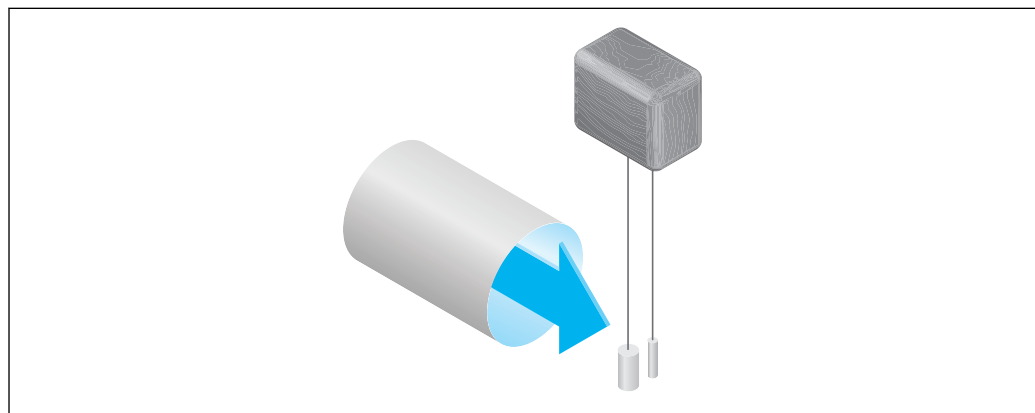

A0016823

Measuring system

The device consists of a transmitter and a sensor.

One device version is available: compact version - transmitter and sensor form a mechanical unit.

Transmitter

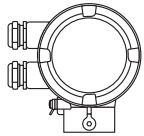
<p>t-mass 150</p>  <p style="text-align: right; font-size: small;">A0015480</p>	<p>Materials: Coated aluminum AlSi10Mg</p> <p>Configuration:</p> <ul style="list-style-type: none"> ■ Four-line local display with key operation and guided menu ("Setup") for applications ■ Operating tools (e.g. FieldCare) <p>Other special features: May also be ordered without local display</p>
---	---

Sensor

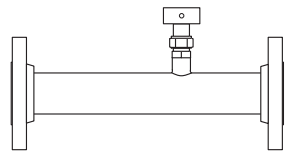
<p>t-mass A</p>  <p style="text-align: right; font-size: small;">A0015481</p>	<ul style="list-style-type: none"> ■ Flange version ■ Nominal diameter range: DN 15 to 50 (½ to 2") ■ Materials: <ul style="list-style-type: none"> ■ Sensor: Stainless steel 1.4404/1.4435/316L ■ Transducer: Stainless steel 1.4404/1.4435/316L ■ Process connections: <ul style="list-style-type: none"> Stainless steel 1.4301/1.4307 Stainless steel 1.4404/316L Galvanized carbon steel 1.0038/A105
---	--

Characteristic values

Measured variable

Direct measured variables

- Mass flow
- Gas temperature





Calculated measured variables

- Corrected volume flow
- FAD (free air delivery) volume flow

Measuring range

The available measuring range depends on the choice of gas, the size of the pipe and the use of a flow conditioner. The measuring device is calibrated with air (under ambient conditions) and the value is converted in order to adapt it to the customer's gas if necessary.

 To obtain information on other gases and process conditions, please contact your Endress +Hauser sales office.

 To calculate the measuring range with and without a flow conditioner (option L →  12 →  15), use the *Applicator* →  31 product selection tool.

The following tables list the ranges available for air (without flow conditioner).

Measuring range "Calibration flow", option G and H →  12

SI units for EN (DIN) flange versions

DN	[kg/h]		[Nm ³ /h] at 0 °C (1.013 bar a)		[Nm ³ /h at 15 °C (1.013 bar a)	
	[mm]	min.	Max.	min.	Max.	min.
15	0.5	53	0.38	41	0.4	43
25	2	200	1.5	155	1.6	164
40	6	555	4.6	429	4.9	453
50	10	910	7.7	704	8.2	744

US units for ASME flange versions

DN	[lb/h]		[Scf/min] at 32 °F (14.7 psi a)		[Scf/min] at 59 °F (14.7 psi a)	
[in]	min.	Max.	min.	Max.	min.	Max.
½	1.1	116	0.23	24	0.24	25
1	4.4	440	0.9	91	1.0	96
1½	13.2	1220	2.7	252	2.9	266
2	22.0	2002	4.5	413	4.8	436

Measuring range "Calibration flow" option K →  12*SI units for EN (DIN) flange versions*

DN	[kg/h]		[Nm³/h] at 0 °C (1.013 bar a)		[Nm³/h] at 15 °C (1.013 bar a)	
[mm]	min.	Max.	min.	Max.	min.	Max.
15	0.5	80	0.38	62	0.24	65
25	2	300	1.5	232	1.0	245
40	6	833	4.6	644	2.3	681
50	10	1365	7.7	1056	4.8	1116

US units for ASME flange versions

DN	[lb/h]		[Scf/min] at 32 °F (14.7 psi a)		[Scf/min] at 59 °F (14.7 psi a)	
[in]	min.	Max.	min.	Max.	min.	Max.
½	1.1	174	0.23	36	0.24	38
1	4.4	660	0.9	136	1.0	144
1½	13.2	1830	2.7	378	2.9	399
2	22.0	3003	4.5	620	4.8	656

Operable flow range

Over 100:1 (over 150:1 for calibration option code K).

Even in the extended measuring range (above the calibrated end value), the flow rate is captured and provided as an output signal. However, the extended range is not subject to the specified measuring uncertainty.

Output

Output signal**Current output**

Current output	4-20 mA HART, active
Maximum output values	<ul style="list-style-type: none"> ▪ DC 24 V (no flow) ▪ 22 mA  If the option Defined value is selected in the Failure mode parameter : 22.5 mA
Load	0 to 750 Ω
Resolution	16 Bit or 0.38 μA
Damping	Adjustable: 0 to 999 s
Assignable measured variables	<ul style="list-style-type: none"> ▪ Mass flow ▪ Corrected volume flow ▪ FAD volume flow ▪ Temperature

Pulse/frequency/switch output

Function	Can be set to pulse, frequency or switching output
Version	Passive, open collector
Maximum input values	<ul style="list-style-type: none"> ▪ DC 30 V ▪ 25 mA
Voltage drop	For 25 mA: ≤ DC 2 V
Pulse output	
Pulse width	Adjustable: 0.5 to 2 000 ms → pulse rate: 0 to 1 000 Pulse/s
Pulse value	Adjustable
Assignable measured variables	<ul style="list-style-type: none"> ▪ Mass flow ▪ Corrected volume flow ▪ FAD volume flow
Frequency output	
Maximum frequency	Adjustable: 0 to 1 000 Hz
Damping	Adjustable: 0 to 999 s
Pulse/pause ratio	1:1
Assignable measured variables	<ul style="list-style-type: none"> ▪ Mass flow ▪ Corrected volume flow ▪ FAD volume flow ▪ Temperature
Switching output	
Switching behavior	Binary, conductive or non-conductive
Switching delay	Adjustable: 0 to 100 s
Number of switching cycles	Unlimited
Assignable functions	<ul style="list-style-type: none"> ▪ Off ▪ On ▪ Diagnostic behavior ▪ Limit value ▪ Status

Signal on alarm

Depending on the interface, failure information is displayed as follows:

Current output

Failure mode	Can be selected (as per NAMUR recommendation NE 43)
Minimum alarm	3.6 mA
Maximum alarm	22 mA
Adjustable value	3.59 to 22.5 mA

Pulse/frequency/switch output

Pulse output	
Failure mode	Choose from: <ul style="list-style-type: none"> ▪ Actual value ▪ No pulses
Frequency output	
Failure mode	Choose from: <ul style="list-style-type: none"> ▪ Actual value ▪ Defined value: 0 to 1250 Hz ▪ 0 Hz

Switching output	
Failure mode	Choose from: <ul style="list-style-type: none"> ■ Current status ■ Open ■ Closed

Local display



Plain text display	With information on cause and corrective action
--------------------	---

 Status signal as per NAMUR recommendation NE 107

Operating tool

- Via digital communication: HART protocol
- Via service interface

Plain text display	With information on cause and corrective action
--------------------	---

 Additional information on remote operation →  28

Low flow cut off The switch point for low flow cut off is programmable.

Galvanic isolation The following connections are galvanically isolated from each other:

- Outputs
- Voltage supply

Protocol-specific data

HART

Manufacturer ID	0x11
Device type ID	0x66
HART protocol revision	6.0
Device description files (DTM, DD)	Information and files under: www.endress.com
HART load	Min. 250 Ω
Dynamic variables	The measured variables can be freely assigned to the dynamic variables. Measured variables for PV (primary dynamic variable) <ul style="list-style-type: none"> ■ Mass flow ■ Corrected volume flow ■ FAD volume flow ■ Temperature Measured variables for SV, TV, QV (secondary, tertiary and quaternary dynamic variable) <ul style="list-style-type: none"> ■ Mass flow ■ Corrected volume flow ■ FAD volume flow ■ Temperature ■ Totalizer

Power supply

Terminal assignment

Transmitter

Connection version 4-20 mA HART, pulse/frequency/switching output

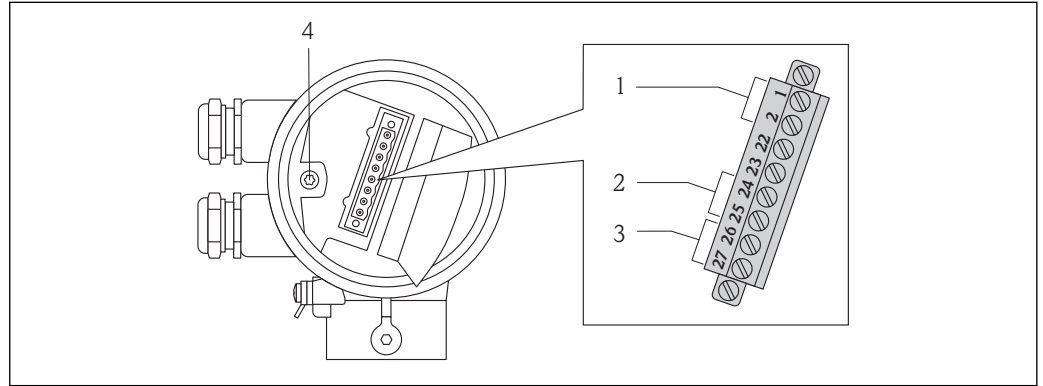

- 1 Supply voltage
- 2 Signal transmission: Pulse/frequency/switching output
- 3 Signal transmission: 4-20 mA HART
- 4 Ground terminal for cable shield

Supply voltage

Order characteristic for "Power supply"	Terminal numbers	
	1 (L+)	2 (L-)
Option D	DC 24 V (18 to 30 V)	

Signal transmission

Order characteristic for "Output"	Terminal numbers			
	Output 1		Output 2	
	26 (+)	27 (-)	24 (+)	25 (-)
Option A	4-20 mA HART active		-	
Option B	4-20 mA HART active		Pulse/frequency/switch output	
Option K	-		Pulse/frequency/switch output	

Supply voltage

DC 24 V (18 to 30 V)

The power supply circuit must comply with SELV/PELV requirements.

Power consumption

Order characteristic for "Output"	Maximum power consumption
<ul style="list-style-type: none"> ▪ Option A: 4-20mA HART ▪ Option B: 4-20mA HART, pulse/frequency/switching output ▪ Option K: Pulse/frequency/switching output 	3.1 W

Current consumption

Order characteristic for "Output"	Maximum current consumption	Maximum switch-on current
<ul style="list-style-type: none"> ■ Option A: 4-20mA HART ■ Option B: 4-20mA HART, pulse/frequency/switching output ■ Option K: Pulse/frequency/switching output 	185 mA	< 2.5 A

Power supply failure

- Totalizers stop at the last value measured.
- Configuration is retained in the device memory.
- Error messages (incl. total operated hours) are stored.

Electrical connection

Connecting the transmitter

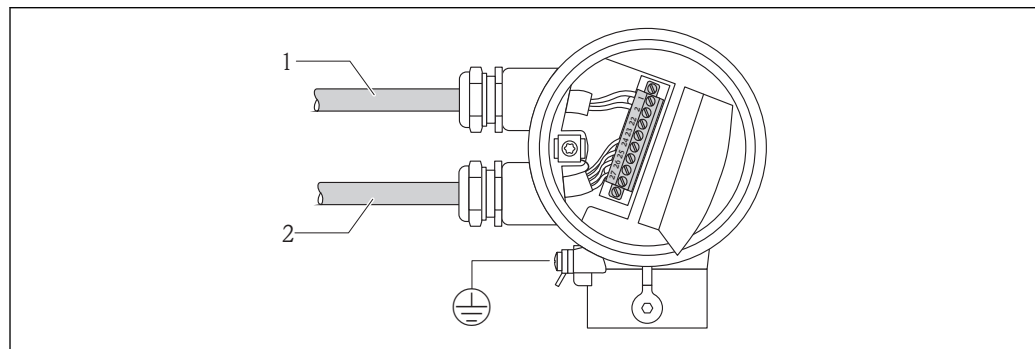

A0017179

- 1 Cable entry for supply voltage
- 2 Cable entry for signal transmission

Connection examples

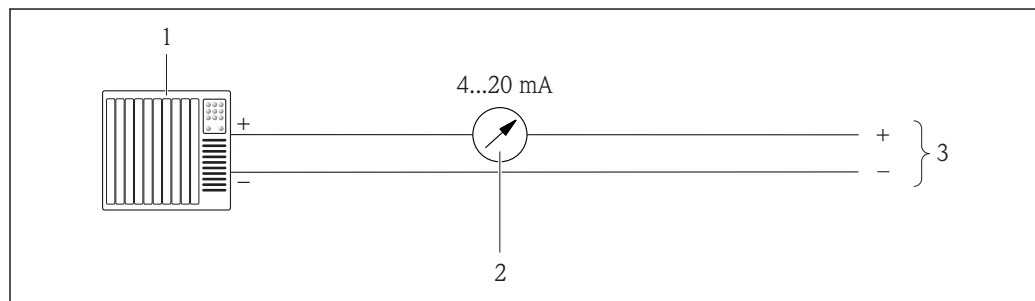

A0016960

- 1 Connection example for current output, 4-20 mA active
- 1 Control system (e.g. PLC)
- 2 Analog display unit: observe maximum load → 6

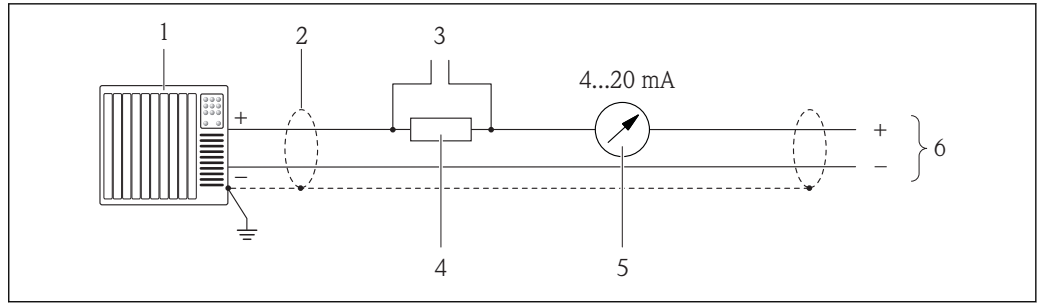

A0016800

2 Connection example for current output, 4-20 mA HART active

- 1 Control system (e.g. PLC)
- 2 Observe cable specification → 12
- 3 Connection for Field Communicator 375/475 or Commubox FXA191/195
- 4 Resistor for HART communication ($\geq 250 \Omega$): observe maximum load → 6
- 5 Analog display unit: observe maximum load → 6

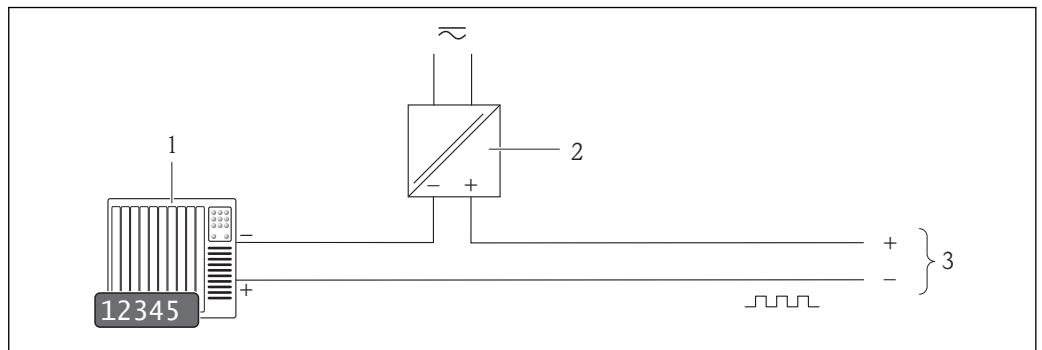

A0016801

3 Connection example for pulse/frequency output (passive)

- 1 Automation system with pulse/frequency input (e.g. PLC)
- 2 Power supply → 12
- 3 Transmitter: Observe input values → 6

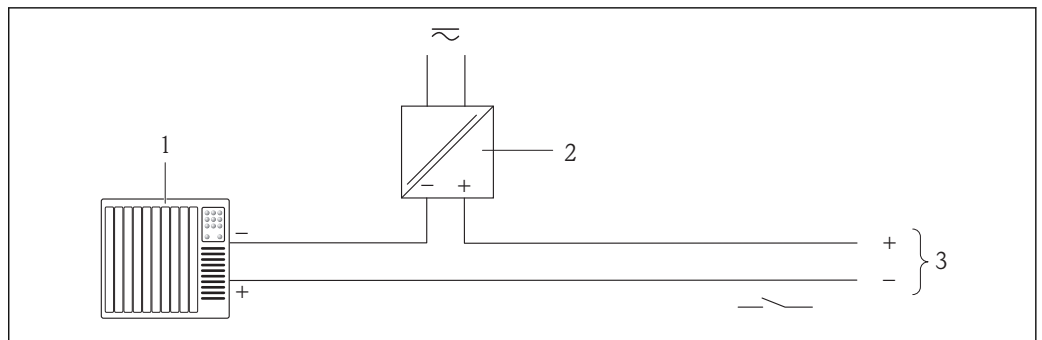

A0016802

4 Connection example for switching output (passive)

- 1 Control system with switch input (e.g. PLC)
- 2 Power supply → 12
- 3 Transmitter: Observe input values → 6

Potential equalization

No special measures for potential equalization are required.

Terminals

Plug-in screw terminals for specified wire cross-sections

Cable entries

- Cable gland: M20 × 1.5 with cable ϕ 6 to 12 mm (0.24 to 0.47 in)
- Thread for cable entry:
 - NPT 1/2"
 - G 1/2"

Cable specification**Wire cross-sectional area**

0.5 to 1.5 mm² (21 to 16 AWG)

Permitted temperature range

- -40 °C (-40 °F)...≥ 80 °C (176 °F)
- Minimum requirement: cable temperature range ≥ ambient temperature + 20 K

Signal cable*Current output*

For 4-20 mA HART: Shielded cable recommended. Observe grounding concept of the plant.

Pulse/frequency/switch output

Standard installation cable is sufficient.

Supply voltage cable

Standard installation cable is sufficient.



Performance characteristics

Reference operating conditions

- Calibration systems traceable to national standards
- Accredited in accordance with ISO/IEC 17025
- Air controlled to 24 °C ± 0.5 °C (75.2 °F ± 0.9 °F) at atmospheric pressure
- Humidity controlled < 40 % RH

Maximum measured error

o.r. = of reading; o.f.s. = of full scale value

-  The full scale value depends upon the nominal diameter of the measuring device and the max. flow of the calibration rig.
- Full scale values of the calibrated measuring range. →  5

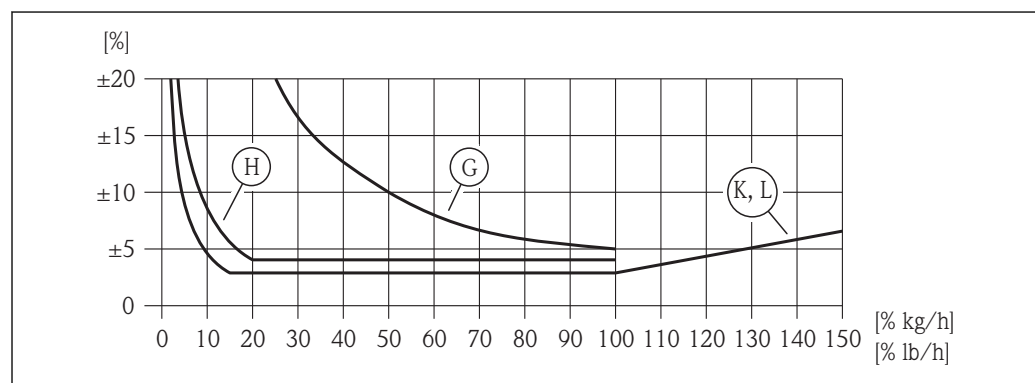

A0016921

-  5 *Maximum measured error (% mass flow) as % of measured value/full scale value. G, H, K, L: Order code options for "Calibration flow", see the following table*

Order code option for "Calibration flow"	Accuracy	Description
K L	<ul style="list-style-type: none"> ▪ Q = 100 to 150 %: from $\pm 3\%$ to $\pm 6.5\%$ of the current measured value increasing linearly as expressed in the following equation: $\pm 3 \pm (X_n - 100) \times 0.07\%$ o.r.] ($100\% < X_n \leq 150\%$; X_n = current flow as a % o.f.s.) ▪ Q = 15 to 100 %: $\pm 3\%$ of current measured value ▪ Q = 1 to 15 % $\pm 0.45\%$ o.f.s. (all data under reference conditions)	The measuring device is calibrated and adjusted on an accredited and traceable calibration rig . The accuracy is certified with a calibration protocol.
H	<ul style="list-style-type: none"> ▪ Q = 20 to 100 % $\pm 4\%$ of current measured value ▪ Q = 1 to 20 % $\pm 0.8\%$ o.f.s. (all data under reference conditions)	The measuring performance of the device is tested, and a verification protocol confirms that the device measures within the specified tolerance.
G	Q = 1 to 100 % $\pm 5\%$ o.f.s. (under reference conditions)	This version is subject to neither a calibration nor a verification of measuring performance.

Accuracy of outputs

Current output

Accuracy	Max. $\pm 0.05\%$ o.f.s. or $\pm 10 \mu A$
-----------------	--

Repeatability	$\pm 0.5\%$ of value for velocities > 1.0 m/s (3.3 ft/s)
Response time	Typically < 3 s for 63 % of a given step change (in both directions)
Influence of medium pressure	Air: 0.35 % of value per bar (0.02 % per psi) of process pressure change

Installation

Mounting location	<p>Thermal measuring devices require a fully developed flow profile as a prerequisite for correct flow measurement. For this reason, please pay attention to the following points and document sections when installing the device:</p> <ul style="list-style-type: none"> ▪ Avoid flow disturbances, as the thermal measuring principle reacts sensitively to them. ▪ Take measures to avoid condensation (e.g. condensation trap, thermal insulation etc.).
Orientation	The direction of the arrow on the sensor helps you to install the sensor according to the flow direction (direction of medium flow through the piping).

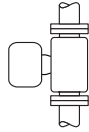
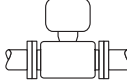
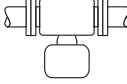
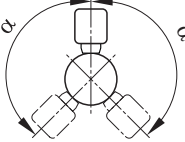
Vertical orientation	 A0017337	✓✓ ¹⁾
Horizontal orientation, transmitter head up	 A0015589	✓✓
Horizontal orientation, transmitter head down	 A0015590	✓✓ ²⁾
Inclined mounting position, transmitter head down	 A0015773	✓ ³⁾

- 1) In the case of saturated or unclean gases, upward flow in a vertical pipe section is preferred to minimize condensation or contamination.
- 2) Suitable only for clean and dry gases. If buildup or condensate are always present: Mount the sensor in an inclined position.
- 3) Select inclined mounting position ($\alpha = \text{approx. } 135^\circ$) if the gas is very wet or saturated with water.

Requirement for pipework

The measuring device must be professionally installed, and the following points must be observed:

- Piping must be professionally welded.
- Seals must be sized correctly.
- Flanges and seals must be correctly aligned.
- The internal pipe diameter on the inlet side must match the internal diameter of the process connection ordered. The maximum permitted deviation between the internal diameters is: 1 mm (0.04 in)
- Following installation, the pipe must be free from dirt and particles in order to avoid damage to the sensors.

Further information → ISO standard 14511

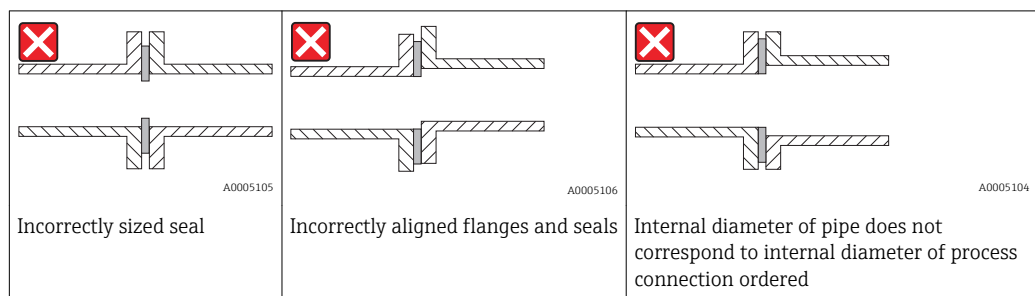

Inlet and outlet runs

The thermal measuring principle is sensitive to disturbed flow conditions.

- As a general rule, the measuring device should always be installed as far away as possible from any flow disturbances. For further information, please refer to → ISO 14511.
- If possible, the sensor should be installed upstream from valves, T-pieces, elbows etc. To attain the specified level of accuracy of the measuring device, the below mentioned inlet and outlet runs must be maintained at minimum. If there are several flow disturbances present, the longest specified inlet run must be maintained.

Recommended inlet and outlet runs (without flow conditioner)

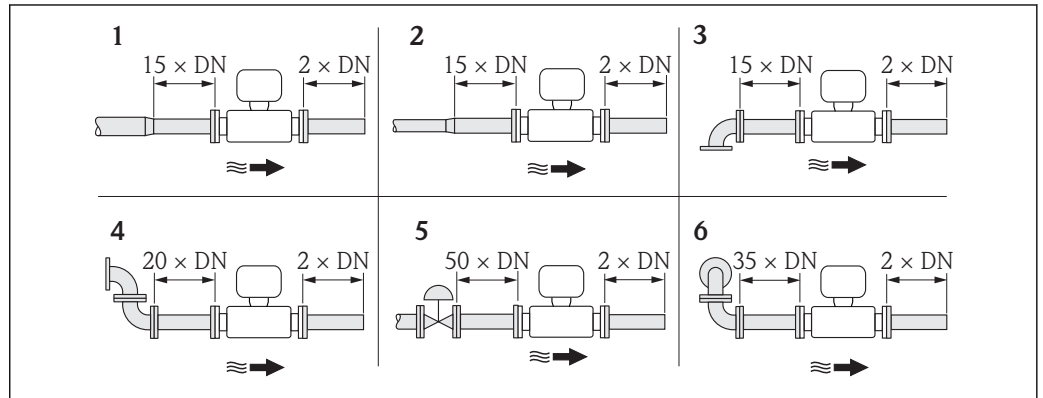

A0016942

- 1 reduction
- 2 expansion
- 3 90° elbow or T-piece
- 4 2 × 90° elbow
- 5 Control valve
- 6 2 × 90° elbow (3-dimensional)

Outlet run for pressure or temperature transmitter

If a pressure or temperature measuring device is installed downstream of the measuring device, make sure there is sufficient distance between the two devices.

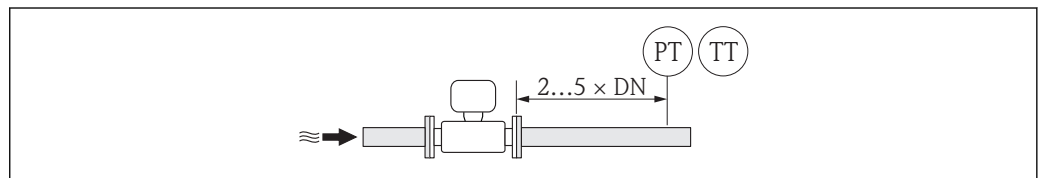

A0015548

- PT Pressure measuring device
- TT Temperature transmitter

Flow conditioner (19 hole) for use with fixed flanges

If the inlet runs cannot be observed, the use of a flow conditioner is recommended.

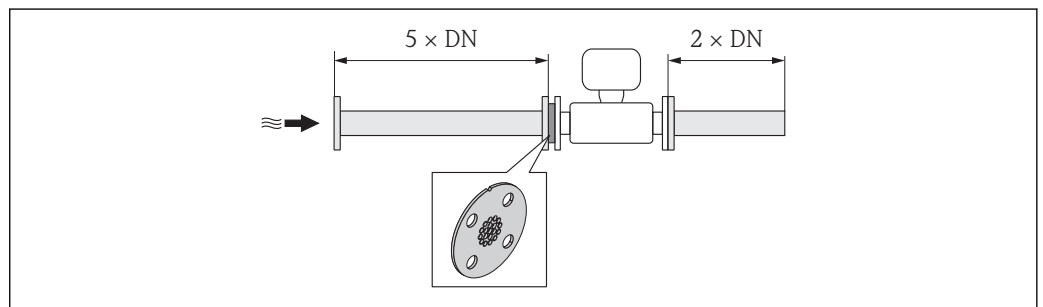

A0015547

- 6 Recommended inlet and outlet runs when using a flow conditioner

This is a special Endress+Hauser design which was developed for the sensor t-mass A 150 (DN 40 to 50 / 1 ½ to 2"). The arrangement of the individual screw holes and their diameter means that the flow conditioner can be used for different flange pressure ratings.

The flow conditioner and the seals are installed between the pipe flange and the measuring system. To ensure correct centering of the flow conditioner, use only standard screws which match the screw holes.

Please note that the flow conditioner must be mounted in such a way that the alignment notch is pointing in the direction of the transmitter. Incorrect installation could have a negative effect on the measurement accuracy.

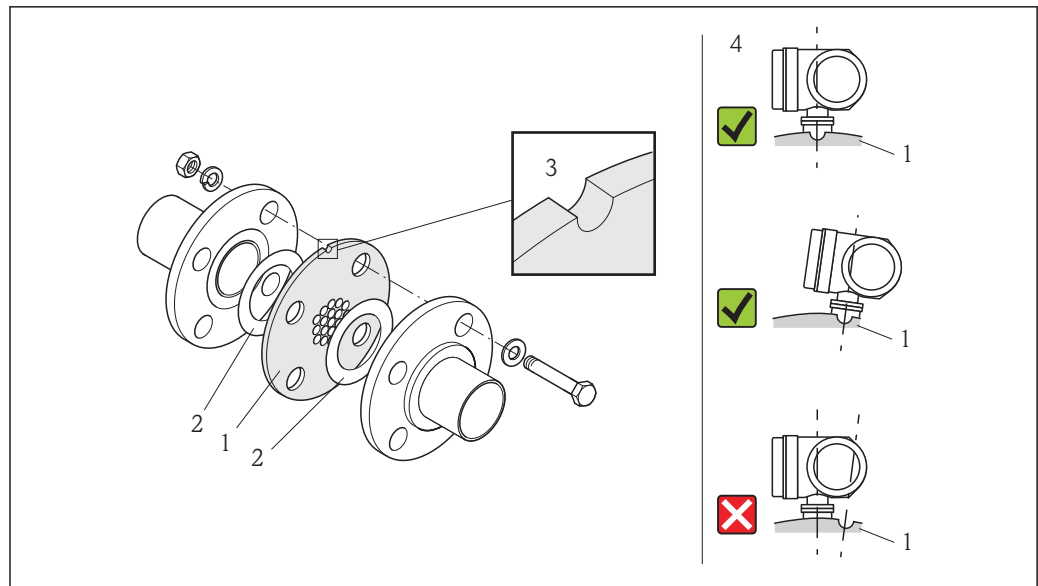

A0005116

- 1 Flow conditioner
 2 Seal
 3 Alignment notch
 4 Correctly align the alignment notch and transmitter.



- Not suitable for lap joint flange or threaded versions!
- Order the sensor and the flow conditioner together to ensure that they are calibrated together. Joint calibration guarantees optimum performance. Ordering the flow conditioner separately and using it with the device will further increase measurement uncertainty.
- The use of flow conditioners from other suppliers will affect the flow profile and pressure drop and will have an adverse effect on performance.
- Screws, nuts, seals etc. are not included in the scope of supply and must be provided by the customer.

Pressure loss

The pressure loss for flow conditioners is calculated as follows:

$$\Delta p = K \cdot \frac{\dot{m}^2}{\rho} \cdot \frac{1}{D^4}$$

A0005243

Δp = Pressure loss [mbar]
 ρ = Density [kg/m³]
 K = Constant 1876 (SI units) or $8.4 \cdot 10^{-7}$ (US units)

\dot{m} = Mass flow [kg/h]
 D = Diameter [mm]

Calculation example

- $\dot{m} = 412$ kg/h
- $\rho = 8.33$ kg/m³ at 7 bar abs. and 20 °C (68 °F)
- D = 42.8 mm for DN 40, PN 40

Calculation in SI units

$$\Delta p = 1876 \cdot (412^2 \div 8.33) \cdot (1 \div 42.8^4) = 11.4 \text{ mbar}$$

Environment

Ambient temperature range	Transmitter	-40 to +60 °C (-40 to +140 °F)
	Sensor	<ul style="list-style-type: none"> ▪ Flange and threaded connection made of stainless steel: -40 to +60 °C (-40 to +140 °F) ▪ Flange connection PN16 made of carbon steel: -10 to +60 °C (-14 to +140 °F) ▪ Flange connection Cl.150 made of carbon steel: -29 to +60 °C (-20.2 to +140 °F)
	Local display	-20 to +60 °C (-4 to +140 °F) The readability of the display may be impaired at temperatures outside the temperature range.

- ▶ If operating outdoors:
Avoid direct sunlight, particularly in warm climatic regions.

Storage temperature	-40 to +80 °C (-40 to +176 °F), preferably at +20 °C (+68 °F)
----------------------------	---

Degree of protection	Transmitter	<ul style="list-style-type: none"> ▪ As standard: IP66/67, type 4X enclosure ▪ When housing is open: IP20, type 1 enclosure ▪ Display module: IP20, type 1 enclosure
	Sensor	IP66/67, type 4X enclosure

Shock resistance	As per IEC/EN 60068-2-31
-------------------------	--------------------------

Vibration resistance	Acceleration up to 2 g, 10 to 150 Hz, as per IEC/EN 60068-2-6
-----------------------------	---

Electromagnetic compatibility (EMC)	As per IEC/EN 61326 and NAMUR Recommendation 21 (NE 21).  For details, refer to the Declaration of Conformity.
--	--

Process

Medium temperature range	Sensor <ul style="list-style-type: none"> ▪ Flange and threaded connection made of stainless steel: -40 to +100 °C (-40 to +212 °F) ▪ Flange connection PN16 made of carbon steel: -10 to +100 °C (-14 to +212 °F) ▪ Flange connection Cl.150 made of carbon steel: -29 to +100 °C (-20.2 to +212 °F)
---------------------------------	---

Pressure-temperature ratings	The following material load diagrams refer to the entire device and not just the process connection.
-------------------------------------	--

Flange connection (fixed flange) as per EN 1092-1 (DIN 2501)

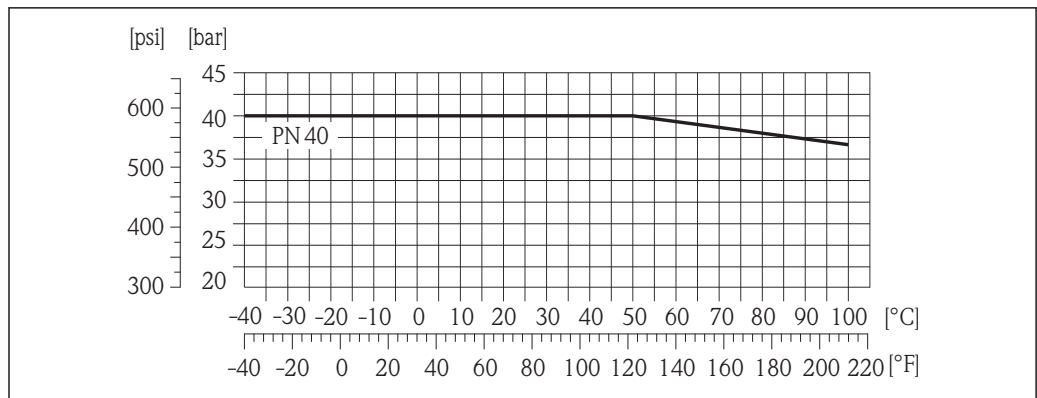

A0016015

7 Flange material 1.4404

Flange connection (fixed flange) as per ASME B16.5

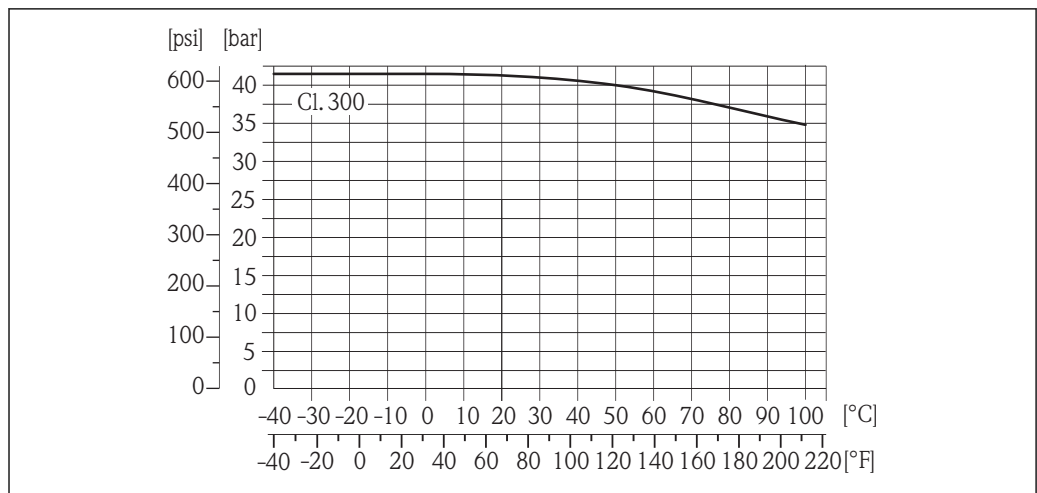

A0016016

8 Flange material 316L

Flange connection (lap joint flange) as per EN 1092-1 (DIN 2501)

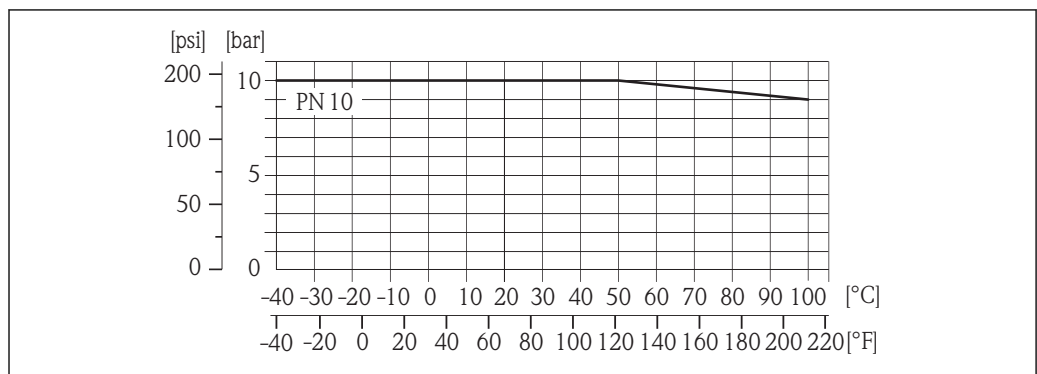

A0016017

9 Flange material 1.4301

Flange connection (lap joint flange) as per EN 1092-1 (DIN 2501)

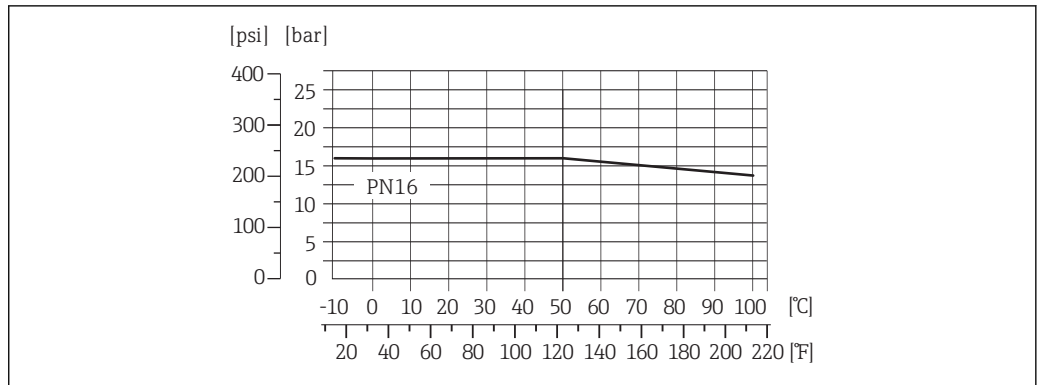

10 Flange material S235JR/1.0038

Flange connection (lap joint flange) as per ASME B16.5

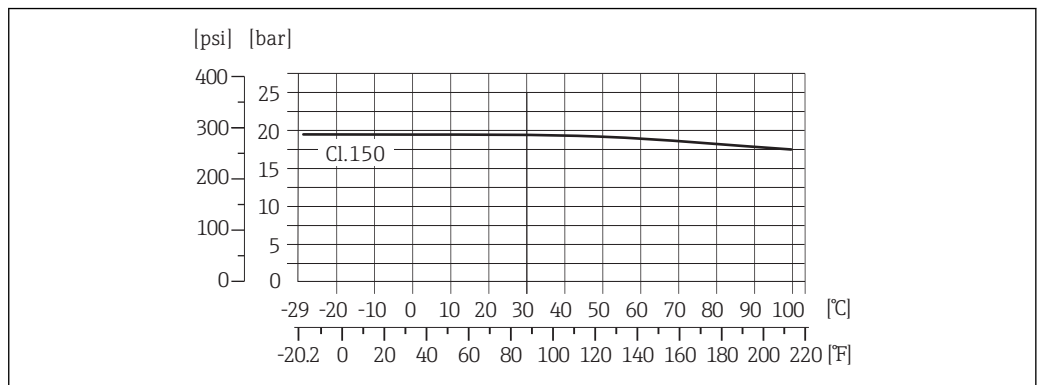

11 Flange material A105

External thread as per EN (DIN), ASME

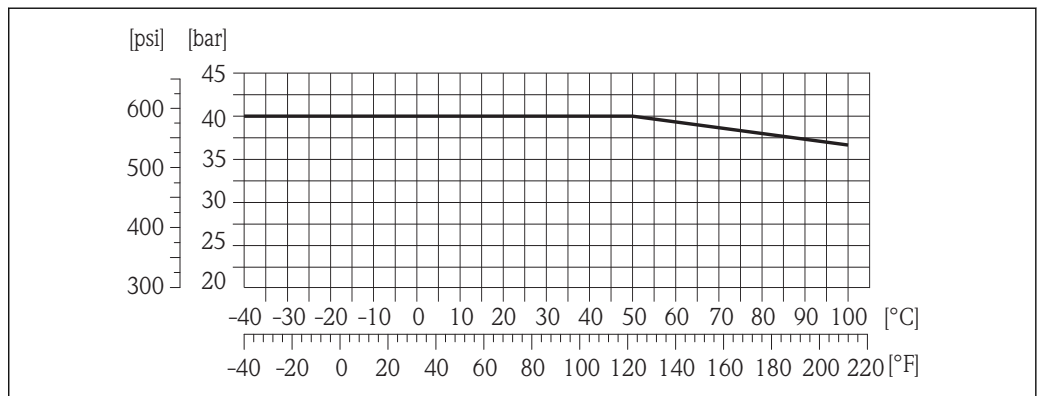

12 Flange material 1.4404/316L

Flow limit

See "Measuring range" → 5 section

The velocity in the measuring tube should not exceed 70 m/s (230 ft/s).

Pressure loss

Negligible (without flow conditioner).

For a precise calculation, use the Applicator.

System pressure

Sensor

Depending on the version, please note the details on the name plate .
Max. 40 bar g (580 psi g)

Thermal insulation

If the gas is very humid or saturated with water, the pipe and the sensor housing should be insulated to prevent water droplets condensing on the transducer.

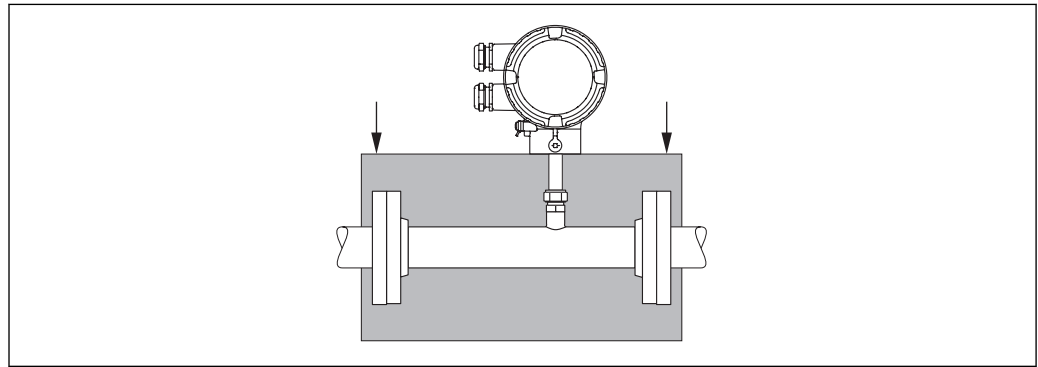

A0015521

Mechanical construction

Design, dimensions

Compact version

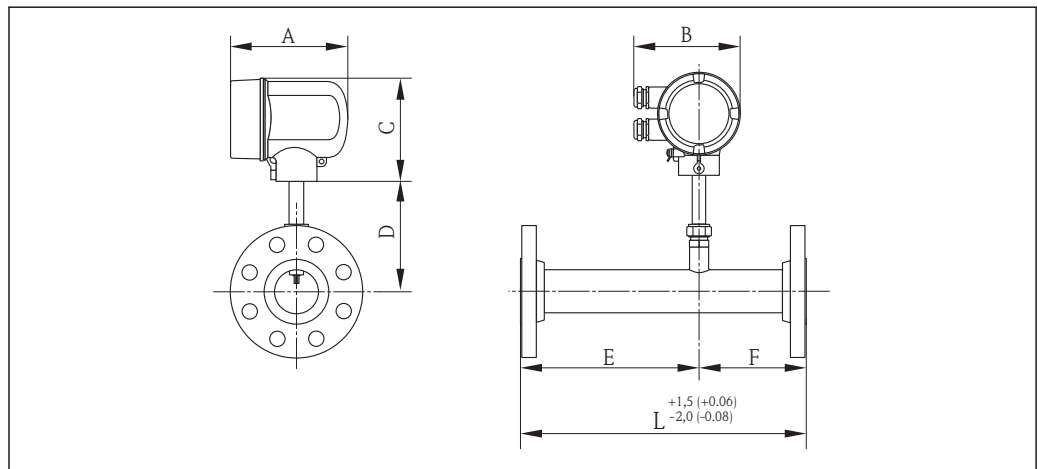

A0015522

Dimensions in SI units

DN [mm]	A ¹⁾ [mm]	B [mm]	C [mm]	D [mm]	E [mm]	F [mm]	L [mm]
15	146	133	129	109	153	92	245
25	146	133	129	115	153	92	245
40	146	133	129	110	200	120	320
50	146	133	129	116	250	150	400

1) For version without local display: values - 7 mm

Dimensions in US units

DN [in]	A ¹⁾ [in]	B [in]	C [in]	D [in]	E [in]	F [in]	L [in]
½	5.75	5.24	5.08	4.29	6.02	3.62	9.65
1	5.75	5.24	5.08	4.53	6.02	3.62	9.65
1½	5.75	5.24	5.08	4.33	7.87	4.72	12.6
2	5.75	5.24	5.08	4.57	9.84	5.91	15.75

1) For version without local display: values -0.28 in

Process connections in SI units

Fixed flanges as per EN (DIN), ASME

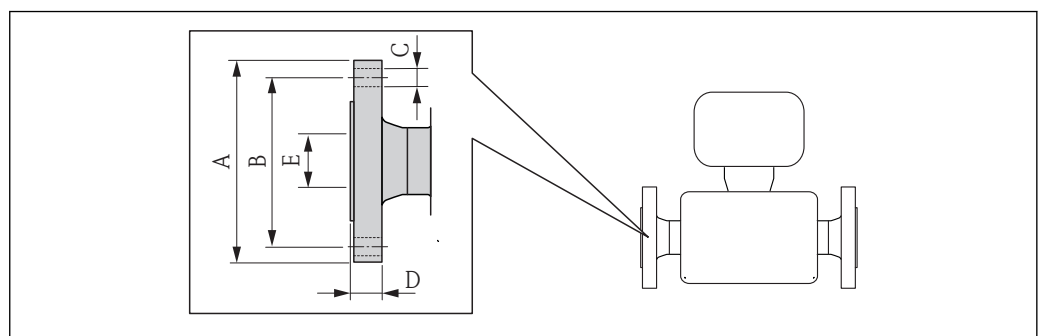

A0017274

Fixed flange as per EN 1092-1 / B1 / PN40

DN [mm]	A [mm]	B [mm]	C [mm]	D [mm]	E [mm]
15	95	65	4 × Ø14	16	15.8
25	115	85	4 × Ø14	18	27.9
40	150	110	4 × Ø18	18	42.8
50	165	125	4 × Ø18	20	54.8

Fixed flanges as per ASME B16.5 / Cl 300

DN [in]	A [mm]	B [mm]	C [mm]	D [mm]	E [mm]
½	95	66.7	4 × Ø15.9	23	15.8
1	125	88.9	4 × Ø19.1	27	27.9
1½	155	114.3	4 × Ø22.2	31	42.8
2	165	127	8 × Ø19.1	34	54.8

Lap joint flanges as per EN (DIN), ASME

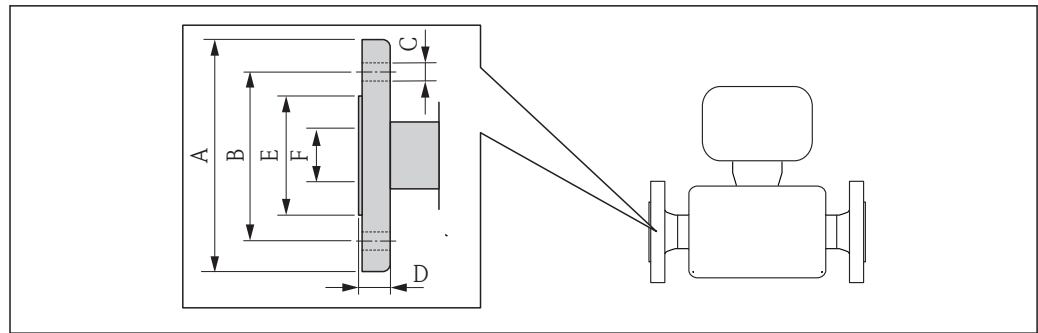

A0017272

Lap joint flange, stamping plate as per EN 1092-1/ PN 10						
DN [mm]	A [mm]	B [mm]	C [mm]	D [mm]	E [mm]	F [mm]
15	95	65	4 × Ø13.5	11.5	34.9	15.8
25	115	85	4 × Ø13.5	16	50.8	27.9
40	150	110	4 × Ø17.5	18	73.0	42.8
50	165	125	4 × Ø17.5	20	92.1	54.8

Lap joint flange as per EN 1092-1/ PN 16						
DN [mm]	A [mm]	B [mm]	C [mm]	D [mm]	E [mm]	F [mm]
15	95	65	4 × Ø14	14	34.9	15.8
25	115	85	4 × Ø14	16	50.8	27.9
40	150	110	4 × Ø18	18	73.0	42.8
50	165	125	4 × Ø18	20	92.1	54.8

Lap joint flanges as per ASME B16.5 / Cl 150						
DN [in]	A [mm]	B [mm]	C [mm]	D [mm]	E [mm]	F [mm]
½	90	60.3	4 × Ø15.9	16	34.9	15.8
1	110	79.4	4 × Ø15.9	18	50.8	27.9
1½	125	98.4	4 × Ø15.9	23	73.0	42.8
2	150	120.7	4 × Ø19.1	26	92.1	54.8

External thread as per EN (DIN), ASME

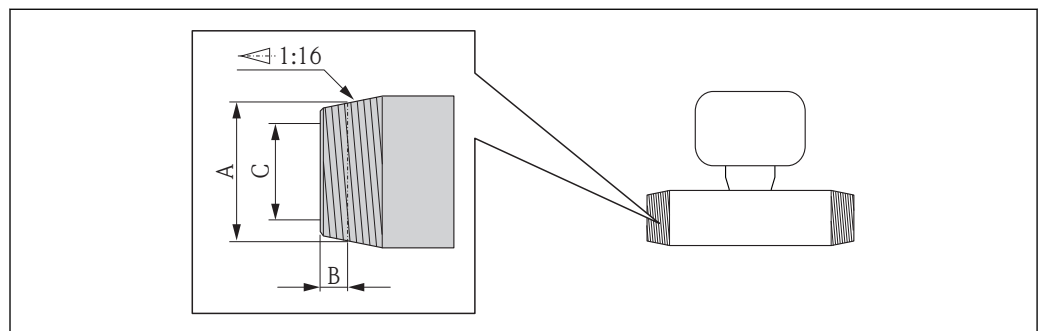

A0017273

R external thread as per EN 10226-1, ISO 7-1			
DN [mm]	A [in]	B [mm]	C [mm]
15	R½	8.2	15.8
25	R1	10.4	26.7
40	R1½	12.7	40.9
50	R2	15.9	52.5

NPT external thread as per ASME B1.20.1			
DN [in]	A [in]	B [mm]	C [mm]
½	½ NPT	8.13	15.8
1	1 NPT	10.16	26.7
1½	1½ NPT	10.67	40.9
2	2 NPT	11.7	52.5

Process connections in US units

Fixed flanges as per ASME

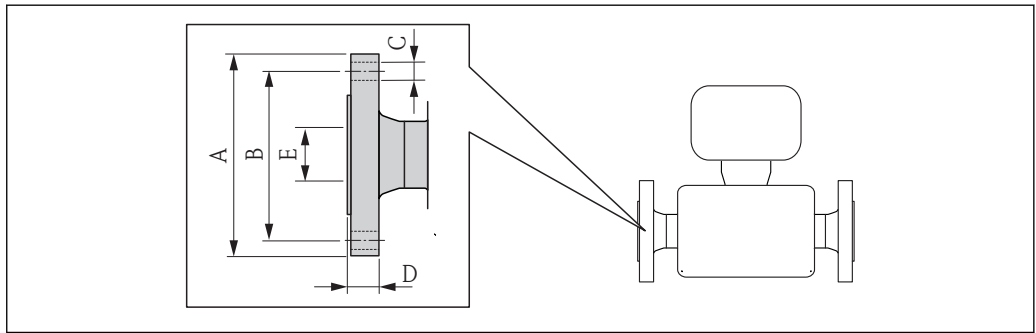

A0017274

Fixed flanges as per ASME B16.5 / Cl 300					
DN [in]	A [in]	B [in]	C [in]	D [in]	E [in]
½	3.74	2.63	4 × Ø ⁵ / ₈	0.91	0.62
1	4.92	3.5	4 × Ø ³ / ₄	1.06	1.1
1½	6.1	4.5	4 × Ø ⁷ / ₈	1.22	1.69
2	6.5	5	4 × Ø ⁹ / ₄	1.34	2.16

Lap joint flanges as per ASME

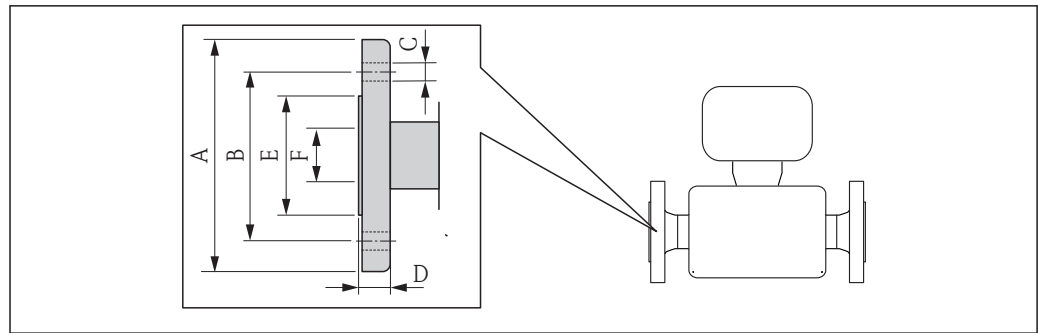

A0017272

Lap joint flanges as per ASME B16.5 / Cl 150						
DN [in]	A [in]	B [in]	C [in]	D [in]	E [in]	F [in]
½	3.54	2.37	4 × Ø ⁵ / ₈	0.63	1.37	0.62
1	4.33	3.13	4 × Ø ⁵ / ₈	0.71	2.00	1.10
1½	4.92	3.87	4 × Ø ⁵ / ₈	0.91	2.87	1.69
2	5.91	4.76	4 × Ø ³ / ₄	1.02	3.63	2.16

External thread as per ASME B1.20.1

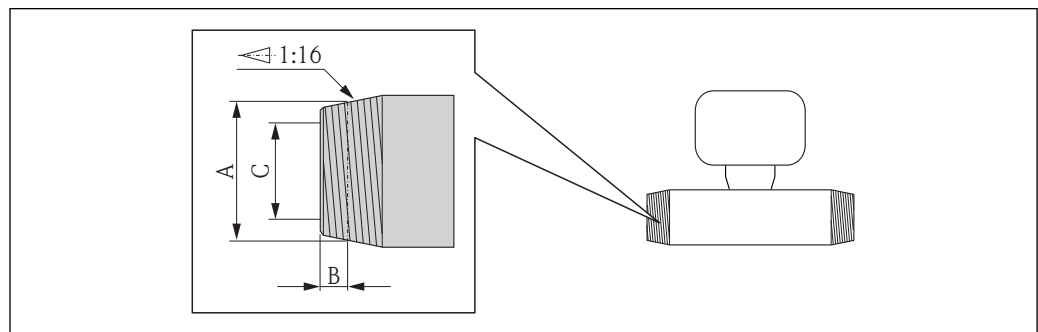

A0017273

NPT external thread as per ASME B1.20.1			
DN [in]	A [in]	B [in]	C [in]
½	½ NPT	0.32	0.62
1	1 NPT	0.4	1.05
1½	1½ NPT	0.42	1.61
2	2 NPT	0.46	2.07

Flow conditioner as per EN(DIN)/ASME

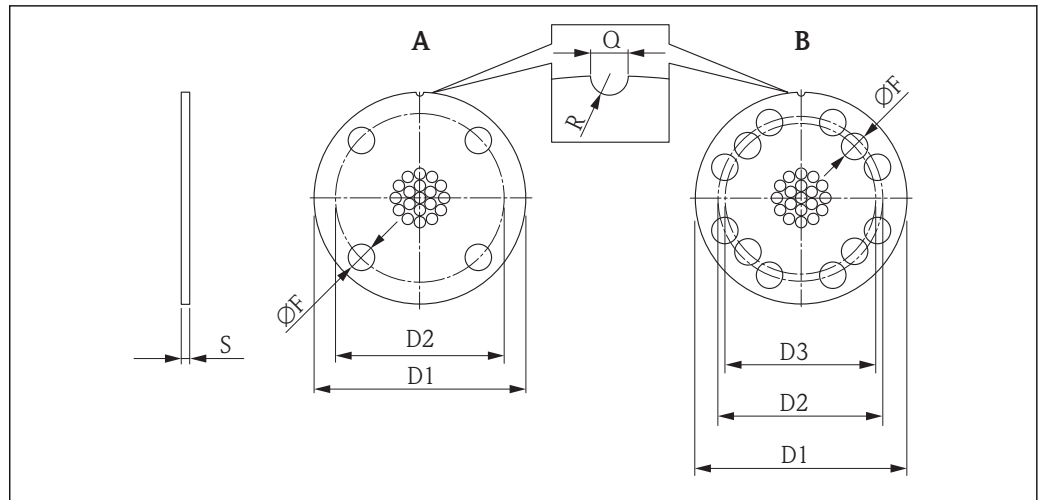

A0015542

Dimensions in SI units

As per EN(DIN) / PN 40

DN	Type	D1	D2	F	Q	R	S	Weight
[mm]		[mm]	[mm]	[mm]	[mm]	[mm]	[mm]	[kg]
40	A	135	108	17	5	2.5	7.0	0.7
50	A	150	123	17	5	2.5	8.5	1.0

As per ASME / Cl 300 Sched 40

DN		Type	D1	D2	D3	F	Q	R	S	Weight
[mm]	[in]		[mm]	[mm]	[mm]	[mm]	[mm]	[mm]	[mm]	[kg]
40	1 ½	B	140	109.5		21.5	5	2.5	6.5	0.9
50	2	B	150	122	115.5	19	5	2.5	8.5	1.3

Dimensions in US units

As per ASME / Cl 300 Sched 40

DN	Type	D1	D2	D3	F	Q	R	S	Weight
[in]		[in]	[in]	[in]	[in]	[in]	[in]	[in]	[lbs]
1 ½	B	5.5	4.31	-	0.85	0.2	0.1	0.26	1.9
2	B	5.9	4.80	4.55	0.7	0.2	0.1	0.33	2.8

Weight

Weight in SI units

Compact version

DN [mm]	Weight [kg]					
	Fixed flange		Lap joint flange			Threaded version
	CL300	PN40	PN16	PN10	CL150	
15	4.0	3.9	4.1	3.2	3.4	2.6
25	5.5	4.8	5.0	3.5	4.3	2.6

DN [mm]	Weight [kg]					
	Fixed flange		Lap joint flange			Threaded version
	CL300	PN40	PN16	PN10	CL150	
40	7.9	7.0	7.5	4.9	6.1	3.1
50	9.9	9.3	9.4	5.9	8.0	3.8

Weight in US units

Compact version

DN [mm]	Weight [lbs]					
	Fixed flange		Lap joint flange			Threaded version
	CL300	PN40	PN16	PN10	CL150	
15	8.8	8.6	9.0	7.1	7.5	5.7
25	12.1	10.6	11.0	7.7	9.5	5.7
40	17.4	15.4	16.5	10.8	13.5	6.8
50	21.8	20.5	20.7	13.0	17.6	8.4

Materials

Transmitter housing

- Order code for "Housing", option **A**: aluminum coating AlSi10Mg
- Window material: glass

Sensor

Process connections

Fixed flanges: EN 1092-1/ ASME B16.5

- Stainless steel 1.4404 as per EN 10222-5
- Stainless steel F316/F316L as per ASTM A182

Lap joint flanges: EN 1092-1/ ASME B16.5

- Stub end:
 - Stainless steel 1.4404/1.4435 as per EN 10216-5; cold worked
 - Stainless steel 316L as per ASTM A312; cold worked
- Lap-joint flange:
 - Galvanized carbon steel 1.0038 as per EN 10025-2
 - Galvanized carbon steel ASTM A105
 - Stainless steel 1.4301/1.4307 as per EN 10028-7

Threaded version: R external thread as per EN 10226-1, ISO 7/1 and NPT external thread as per ASME B1.20.1

- Stainless steel 1.4404/1.4435 as per EN 10216-5
- Stainless steel 316L as per ASTM A312

Measuring tube

- DN 15 (½ in)
 - Stainless steel 1.4404 as per EN 10272/EN10216-5
 - Stainless steel 316/316L as per ASTM A479/ ASTM A312
- DN 25 to 50 (1 to 2 in)
 - Stainless steel 1.4404 as per EN 10216-5
 - Stainless steel 316/316L as per ASTM A312

Sensing element

- Stainless steel 1.4404/1.4435 as per EN 10216-5/ EN10272/ EN 10028-7
- Stainless steel 316L as per ASTM A269/ ASTM A479/ ASTM A240

Cable entries

Order characteristic for "Housing", option A: compact, aluminum coating

Electrical connection	Type of protection	Material
Cable gland M20 × 1.5	For non-hazardous areas	Plastic
Thread G ½" via adapter	For non-Ex and Ex	Nickel-plated brass
Thread NPT ½" via adapter		

Accessories

Flow conditioner as per EN(DIN)/ASME

1.4404 as per EN 10272 and 316L as per A479

1.4404 as per EN 10216-5 and 316L as per A312

Process connections

- Lap joint flanges, fixed flanges
 - as per EN 1092-1
 - as per ASME B16.5
- External thread
 - R external thread as per EN 10226-1
 - NPT external thread as per ASME B1.20.1



For information on the materials of the process connections

Operability

Operating concept

Operator-oriented menu structure for user-specific tasks

- Commissioning
- Operation
- Diagnostics
- Expert level

Quick and safe commissioning

Menu guidance with brief explanations of the individual parameter functions

Reliable operation

- Operation in different languages: → 29
 - Via local display
 - Via operating tools
- Uniform operating philosophy applied to device and operating tools

Efficient diagnostics increase measurement reliability

- Remedial information is integrated in plain text
- Diverse simulation options and optional line recorder functions

Local operation

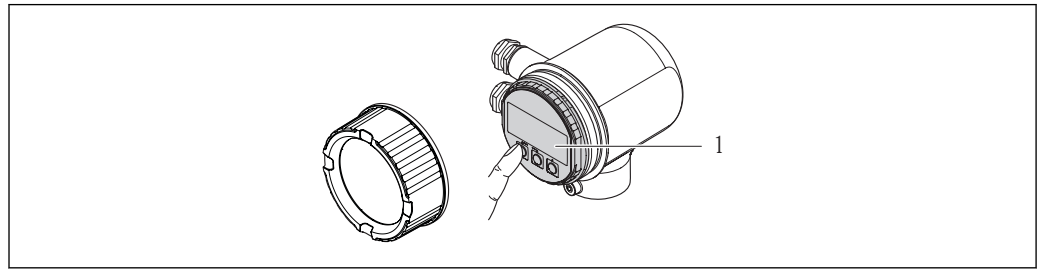
"Display; Operation" Order code option C

A0017279

1 Display module (pushbutton operation)

Display elements

- 4-line display
- Format for displaying measured variables and status variables can be individually configured
- Permitted ambient temperature for the display: -20 to $+60$ °C (-4 to $+140$ °F)
The readability of the display may be impaired at temperatures outside the temperature range.

Operating elements

Local operation with 3 push buttons (⊖, ⊕, ⊞)

Additional functionality

- Data backup function
The device configuration can be saved in the display module.
- Data comparison function
The device configuration saved in the display module can be compared to the current device configuration.
- Data transfer function
The transmitter configuration can be transmitted to another device using the display module.

Remote operation

Via HART protocol

This communication interface is present in the following device version:

- Order characteristic for "Outlet", option **A**: 4-20 mA HART
- Order characteristic for "Outlet", option **B**: 4-20 mA HART, pulse/frequency/switching output

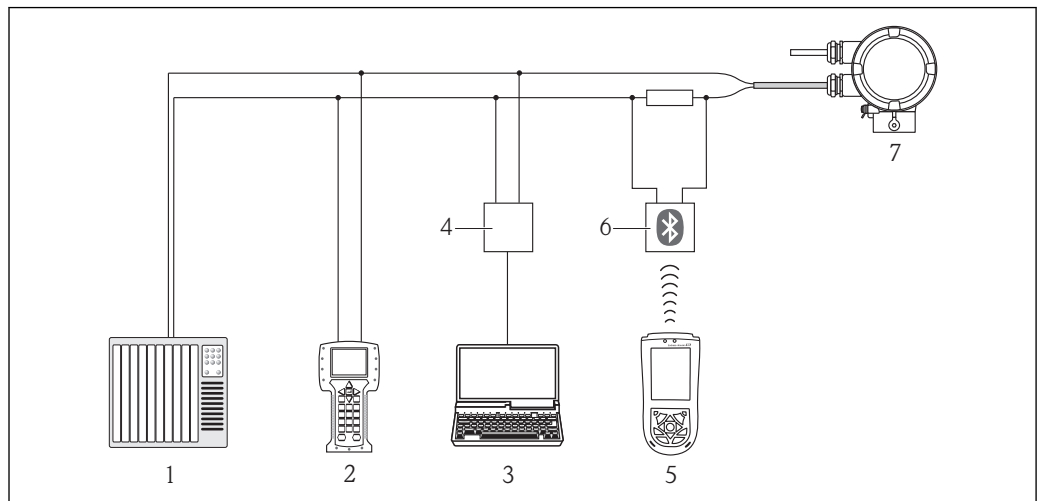

A0017373

13 Options for remote operation via HART protocol

- 1 Control system (e.g. PLC)
- 2 Field Communicator 475
- 3 Computer with operating tool (e.g. FieldCare, AMS Device Manager, SIMATIC PDM)
- 4 Commubox FXA195 (USB)
- 5 Field Xpert SFX100
- 6 VIATOR Bluetooth modem with connecting cable
- 7 Transmitter

Via service interface (CDI)

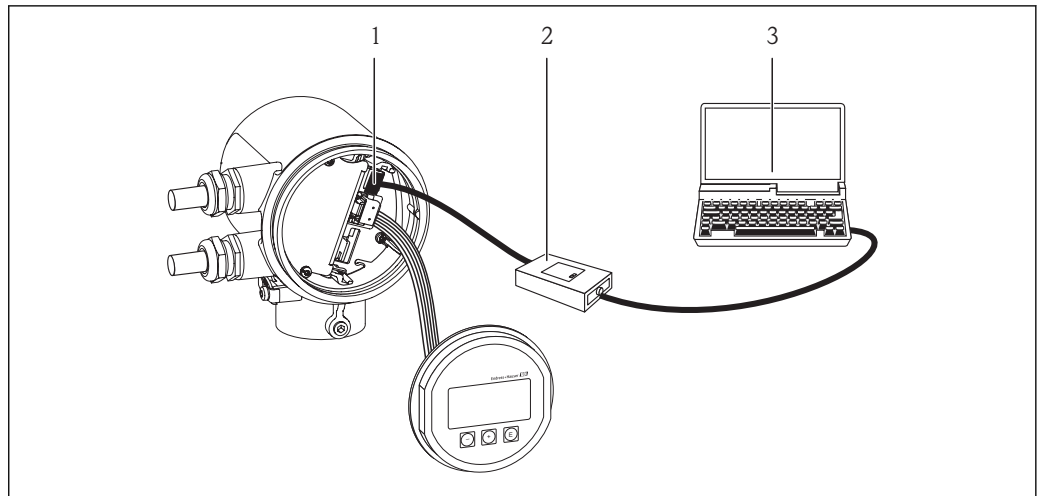

- 1 Service interface (CDI) of the measuring device
- 2 Commubox FXA291
- 3 Computer with "FieldCare" operating tool

A0017253

Languages

Can be operated in the following languages:

- Via local display:
English, German, French, Spanish, Italian, Dutch, Portuguese, Polish, Russian, Turkish, Japanese, Chinese, Korean, Bahasa (Indonesian), Vietnamese, Czech
- Via operating tools:
English, German, French, Spanish, Italian, Dutch, Portuguese, Polish, Russian, Turkish, Japanese, Chinese, Korean, Bahasa (Indonesian), Vietnamese, Czech

Certificates and approvals

CE mark

The measuring system is in conformity with the statutory requirements of the applicable EC Directives. These are listed in the corresponding EC Declaration of Conformity along with the standards applied.

Endress+Hauser confirms successful testing of the device by affixing to it the CE mark.

C-Tick symbol

The measuring system meets the EMC requirements of the "Australian Communications and Media Authority (ACMA)".

Ex approval

cCSA_{US}

The following hazardous area versions currently available:

NI

Class 1, Division 2, Groups A, B, C and D T4 or Class I, Zone 2 IIC T4

Pressure Equipment Directive

The devices can be ordered with or without a PED approval. If a device with a PED approval is required, this must be explicitly stated in the order.

- With the PED/G1/x (x = category) marking on the sensor nameplate, Endress+Hauser confirms compliance with the "Essential Safety Requirements" specified in Annex I of the Pressure Equipment Directive 97/23/EC.
- Devices bearing this marking (PED) are suitable for the following types of medium:
Media in Group 1 and 2 with a vapor pressure greater than, or smaller and equal to 0.5 bar (7.3 psi)
- Devices not bearing this marking (PED) are designed and manufactured according to good engineering practice. They meet the requirements of Art.3 Section 3 of the Pressure Equipment Directive 97/23/EC. The range of application is indicated in tables 6 to 9 in Annex II of the Pressure Equipment Directive.

Other standards and guidelines

- EN 60529
Degrees of protection provided by enclosures (IP code)
- EN 61010-1
Protection Measures for Electrical Equipment for Measurement, Control, Regulation and Laboratory Procedures.
- IEC/EN 61326
Emission in accordance with Class A requirements. Electromagnetic compatibility (EMC requirements)
- NAMUR NE 21
Electromagnetic compatibility (EMC) of industrial process and laboratory control equipment.
- NAMUR NE 32
Data retention in the event of a power failure in field and control instruments with microprocessors
- NAMUR NE 43
Standardization of the signal level for the breakdown information of digital transmitters with analog output signal.
- NAMUR NE 53
Software of field devices and signal-processing devices with digital electronics
- NAMUR NE 105
Specifications for integrating fieldbus devices in engineering tools for field devices
- NAMUR NE 107
Status classification as per NE107

Ordering information

Your Endress+Hauser sales center can provide detailed ordering information and information on the extended order code.

Application packages

Package	Description
HistoROM extended function	<p>Comprises extended functions concerning the event log and the activation of the measured value memory.</p> <p>Event log:</p> <ul style="list-style-type: none"> ■ Memory volume is extended from 20 message entries (basic version) to up to 100 entries. ■ Message entries are visualized via the local display or FieldCare. <p>Data logging (line recorder):</p> <ul style="list-style-type: none"> ■ Memory capacity for up to 1000 measured values is activated. ■ 250 measured values can be output via each of the 4 memory channels. The recording interval can be defined and configured by the user. ■ Data logging is visualized via the local display or FieldCare.







Accessories

Device-specific accessories

For the sensor

Accessories	Description
Flow conditioner	<p>For DN 40–50 (1½" - 2"), PN40, CI 300</p> <p>Order the t-mass A sensor and the flow conditioner together to ensure that they are calibrated together. Joint calibration guarantees optimum performance. Ordering the flow conditioner separately and using it with the device will further increase measurement uncertainty.</p>

Communication-specific accessories

Accessories	Description
Commubox FXA195 HART	For intrinsically safe HART communication with FieldCare via the USB interface.  For details, see "Technical Information" TI00404F
HART Loop Converter HMX50	Is used to evaluate and convert dynamic HART process variables to analog current signals or limit values.  For details, see "Technical Information" TI00429F and Operating Instructions BA00371F
Wireless HART adapter SWA70	Is used for the wireless connection of field devices. The WirelessHART adapter can be easily integrated into field devices and existing infrastructures, offers data protection and transmission safety and can be operated in parallel with other wireless networks with minimum cabling complexity.  For details, see Operating Instructions BA00061S
Fieldgate FXA320	Gateway for the remote monitoring of connected 4-20 mA measuring devices via a Web browser.  For details, see "Technical Information" TI00025S and Operating Instructions BA00053S
Fieldgate FXA520	Gateway for the remote diagnostics and remote configuration of connected HART measuring devices via a Web browser.  For details, see "Technical Information" TI00025S and Operating Instructions BA00051S
Field Xpert SFX100	Compact, flexible and robust industry handheld terminal for remote configuration and for obtaining measured values via the HART current output (4-20 mA).  For details, see Operating Instructions BA00060S
Commubox FXA291	Connects Endress+Hauser field devices with a CDI interface (= Endress+Hauser Common Data Interface) and the USB port of a computer or laptop.  For details, see "Technical Information" TI00405C

Service-specific accessories

Accessories	Description
Applicator	Software for selecting and sizing Endress+Hauser measuring devices: <ul style="list-style-type: none"> Calculation of all the necessary data for identifying the optimum flowmeter: e.g. nominal diameter, pressure loss, accuracy or process connections. Graphic illustration of the calculation results Administration, documentation and access to all project-related data and parameters over the entire life cycle of a project. Applicator is available: <ul style="list-style-type: none"> Via the Internet: https://wapps.endress.com/applicator On CD-ROM for local PC installation.
W@M	Life cycle management for your plant W@M supports you with a wide range of software applications over the entire process: from planning and procurement, to the installation, commissioning and operation of the measuring devices. All the relevant device information, such as the device status, spare parts and device-specific documentation, is available for every device over the entire life cycle. The application already contains the data of your Endress+Hauser device. Endress+Hauser also takes care of maintaining and updating the data records. W@M is available: <ul style="list-style-type: none"> Via the Internet: www.endress.com/lifecyclemanagement On CD-ROM for local PC installation.

FieldCare	<p>FDT-based plant asset management tool from Endress+Hauser. It can configure all smart field units in your system and helps you manage them. By using the status information, it is also a simple but effective way of checking their status and condition.</p> <p> For details, see Operating Instructions BA00027S and BA00059S</p>
-----------	--

System components

Accessories	Description
Memograph M graphic display recorder	<p>The Memograph M graphic data manager provides information on all the relevant measured variables. Measured values are recorded correctly, limit values are monitored and measuring points analyzed. The data are stored in the 256 MB internal memory and also on a SD card or USB stick.</p> <p> For details, see "Technical Information" TI00133R and Operating Instructions BA00247R</p>

Documentation



The following document types are available:

- On the CD-ROM supplied with the device
- In the Download Area of the Endress+Hauser Internet site: www.endress.com → Download

Standard documentation

Device type	Communication	Document type	Documentation code
6AAB**-	----	Brief Operating Instructions	KA01103D
	HART	Operating Instructions	BA01042D

Supplementary device-dependent documentation

Device type	Document type	Approval	Documentation code
6AAB**-	Information on the Pressure Equipment Directive		
	Installation Instructions		Specified for each individual accessory →  30

Registered trademarks

HART®

Registered trademark of the HART Communication Foundation, Austin, USA

Applicator®, FieldCare®, Field Xpert™, HistoROM®

Registered or registration-pending trademarks of the Endress+Hauser Group

www.addresses.endress.com
