

Operating Instructions

Flowfit CPA240

Flow assembly for 12 mm sensors

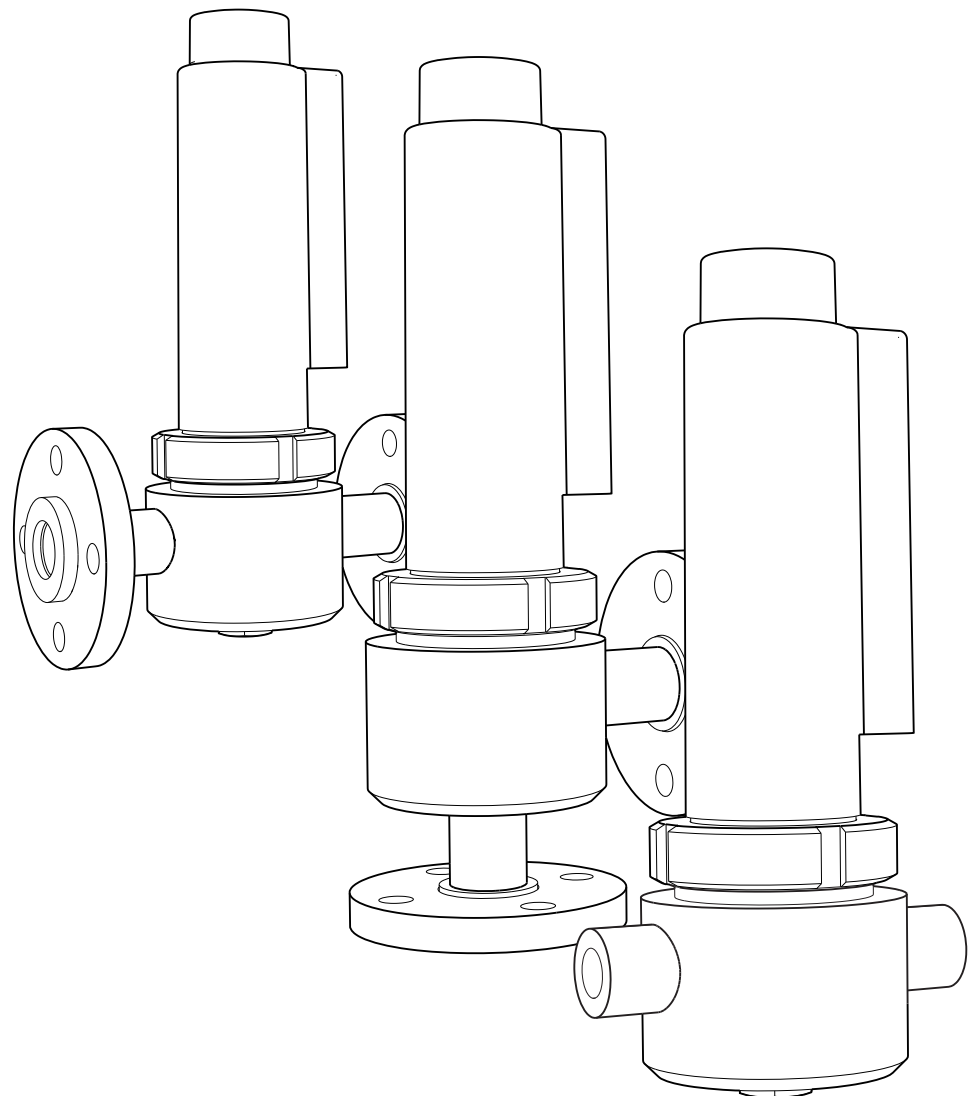





Table of contents







1	About this document	4
1.1	Warnings	4
1.2	Symbols used	4
1.3	Symbols on the device	4
2	Basic safety instructions	5
2.1	Requirements for the personnel	5
2.2	Designated use	5
2.3	Workplace safety	5
2.4	Operational safety	5
2.5	Product safety	5
3	Product description	6
3.1	Stainless steel version	6
3.2	PVDF version	7
4	Incoming acceptance and product identification	8
4.1	Incoming acceptance	8
4.2	Scope of delivery	8
4.3	Product identification	8
5	Installation	10
5.1	Installation conditions	10
5.2	Mounting the assembly	13
5.3	Mounting the sensor	15
5.4	Post-installation check	20
6	Maintenance	21
6.1	Cleaning the assembly	21
6.2	Cleaning agent	21
7	Repair	22
7.1	Spare parts	22
7.2	Return	22
7.3	Disposal	22
8	Accessories	23
8.1	Sensors (selection)	23
8.2	Measuring cable	23
8.3	KCl supply vessel	23
9	Technical data	24
9.1	Environment	24
9.2	Process	24
9.3	Mechanical construction	24
	Index	26

1 About this document

1.1 Warnings

Structure of information	Meaning
<p> DANGER</p> <p>Causes (/consequences) If necessary, Consequences of non-compliance (if applicable)</p> <ul style="list-style-type: none"> ▶ Corrective action 	<p>This symbol alerts you to a dangerous situation. Failure to avoid the dangerous situation will result in a fatal or serious injury.</p>
<p> WARNING</p> <p>Causes (/consequences) If necessary, Consequences of non-compliance (if applicable)</p> <ul style="list-style-type: none"> ▶ Corrective action 	<p>This symbol alerts you to a dangerous situation. Failure to avoid the dangerous situation can result in a fatal or serious injury.</p>
<p> CAUTION</p> <p>Causes (/consequences) If necessary, Consequences of non-compliance (if applicable)</p> <ul style="list-style-type: none"> ▶ Corrective action 	<p>This symbol alerts you to a dangerous situation. Failure to avoid this situation can result in minor or more serious injuries.</p>
<p>NOTICE</p> <p>Cause/situation If necessary, Consequences of non-compliance (if applicable)</p> <ul style="list-style-type: none"> ▶ Action/note 	<p>This symbol alerts you to situations which may result in damage to property.</p>

1.2 Symbols used

Symbol	Meaning
	Additional information, tips
	Permitted or recommended
	Not permitted or not recommended
	Reference to device documentation
	Reference to page
	Reference to graphic
	Result of a step

1.3 Symbols on the device

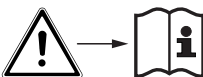
Symbol	Meaning
	Reference to device documentation

2 Basic safety instructions

2.1 Requirements for the personnel

- Installation, commissioning, operation and maintenance of the measuring system may be carried out only by specially trained technical personnel.
- The technical personnel must be authorized by the plant operator to carry out the specified activities.
- The electrical connection may be performed only by an electrical technician.
- The technical personnel must have read and understood these Operating Instructions and must follow the instructions contained therein.
- Faults at the measuring point may only be rectified by authorized and specially trained personnel.

 Repairs not described in the Operating Instructions provided must be carried out only directly at the manufacturer's site or by the service organization.

2.2 Designated use

The assembly is designed for the installation of 12 mm sensors with a Pg 13.5 coupling (length: 120 mm) in pipes. Thanks to its design, it can be operated in pressurized systems.

The assembly is designed exclusively for use in liquid media.

Use of the device for any purpose other than that described, poses a threat to the safety of people and of the entire measuring system and is therefore not permitted.

The manufacturer is not liable for damage caused by improper or non-designated use.

2.3 Workplace safety

As the user, you are responsible for complying with the following safety conditions:

- Installation guidelines
- Local standards and regulations

2.4 Operational safety

Before commissioning the entire measuring point:

1. Verify that all connections are correct.
2. Ensure that electrical cables and hose connections are undamaged.
3. Do not operate damaged products, and protect them against unintentional operation.
4. Label damaged products as defective.

During operation:

- ▶ If faults cannot be rectified:
products must be taken out of service and protected against unintentional operation.

2.5 Product safety

The product is designed to meet state-of-the-art safety requirements, has been tested, and left the factory in a condition in which it is safe to operate. The relevant regulations and international standards have been observed.

3 Product description

3.1 Stainless steel version

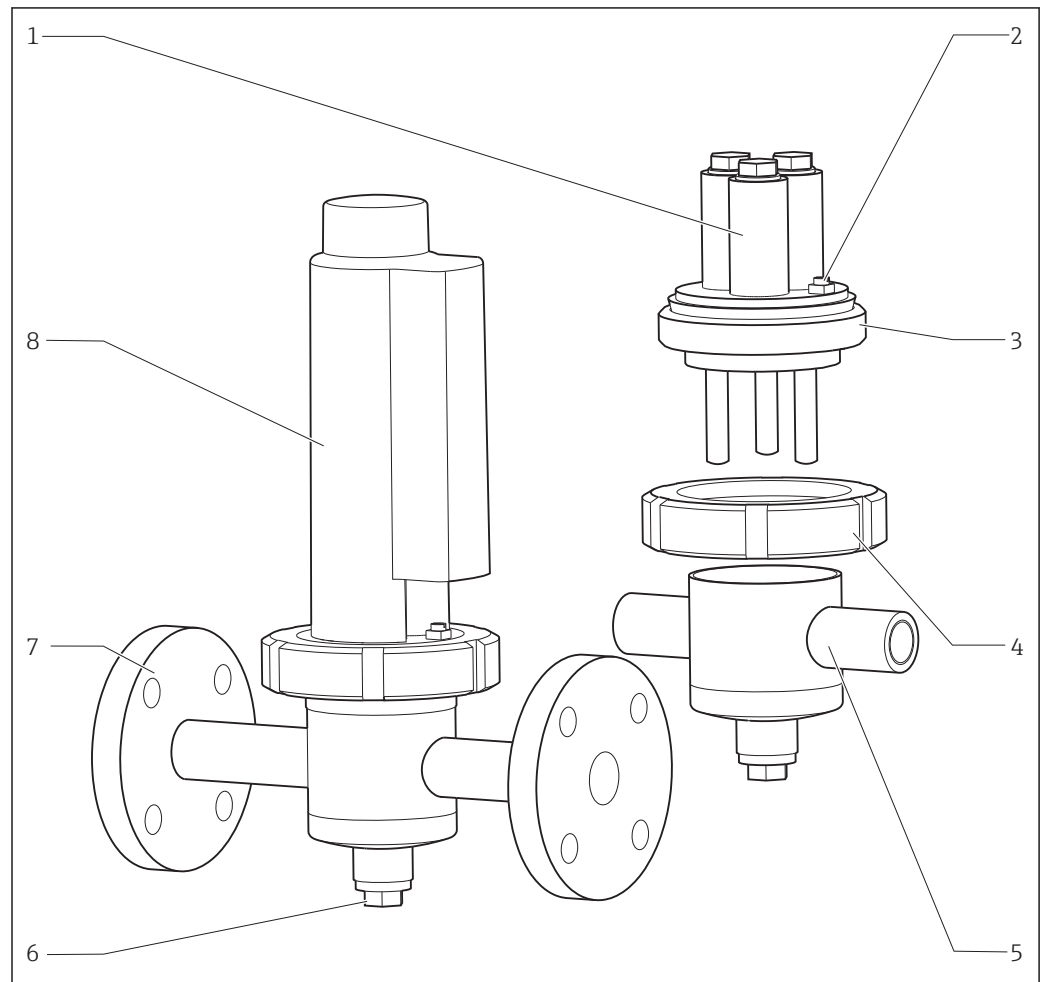

A0037607

1 Stainless steel versions

- 1 3 sensor mounting slots
- 2 Potential matching connection (PML)
- 3 Sensor holder
- 4 Union nut
- 5 Process connection, version A, with NPT $\frac{1}{2}$ " thread
- 6 Drain screw
- 7 Process connection, version A, with fixed flange
- 8 Protection cover

3.2 PVDF version

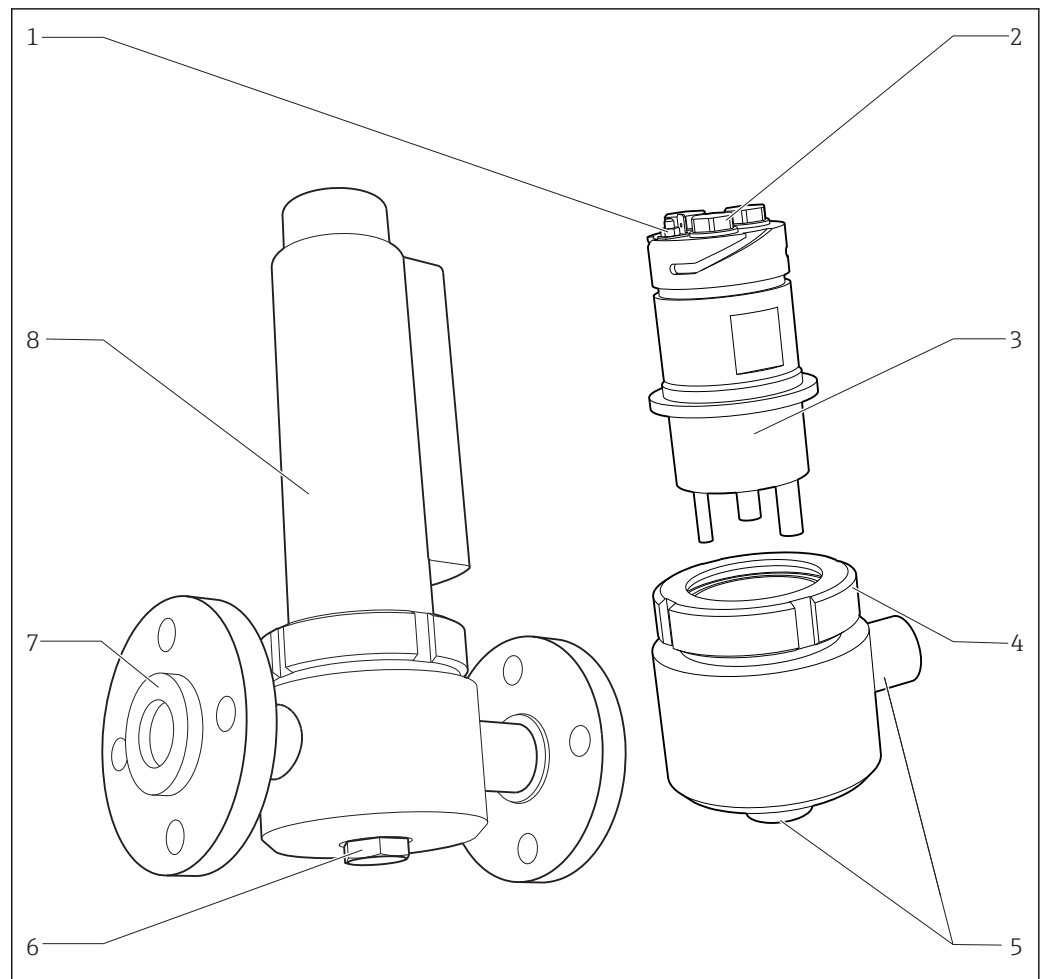

A0039011

2 PVDF versions

- 1 Potential matching connection (PML)
- 2 3 sensor mounting slots
- 3 Sensor holder
- 4 Union nut
- 5 Process connection, version B, with NPT $\frac{1}{2}$ " thread
- 6 Drain screw
- 7 Process connection, version A, with lap joint flange
- 8 Protection cover

4 Incoming acceptance and product identification

4.1 Incoming acceptance

1. Verify that the packaging is undamaged.
 - ↳ Notify the supplier of any damage to the packaging.
Keep the damaged packaging until the issue has been resolved.
2. Verify that the contents are undamaged.
 - ↳ Notify the supplier of any damage to the delivery contents.
Keep the damaged goods until the issue has been resolved.
3. Check that the delivery is complete and nothing is missing.
 - ↳ Compare the shipping documents with your order.
4. Pack the product for storage and transportation in such a way that it is protected against impact and moisture.
 - ↳ The original packaging offers the best protection.
Make sure to comply with the permitted ambient conditions.

If you have any questions, please contact your supplier or your local Sales Center.

4.2 Scope of delivery

The scope of delivery comprises:

- Ordered version of assembly
- Operating Instructions

4.3 Product identification

4.3.1 Nameplate

The nameplate provides you with the following information on your device:

- Manufacturer identification
- Order code
- Extended order code
- Serial number
- Ambient and process conditions
- Safety information and warnings

- ▶ Compare the information on the nameplate with the order.

4.3.2 Product identification

Product page

www.endress.com/cpa240

Interpreting the order code

The order code and serial number of your product can be found in the following locations:

- On the nameplate
- In the delivery papers

Obtaining information on the product

1. Go to www.endress.com.
2. Call up the site search (magnifying glass).
3. Enter a valid serial number.
4. Search.
 - ↳ The product structure is displayed in a popup window.
5. Click on the product image in the popup window.
 - ↳ A new window (**Device Viewer**) opens. All of the information relating to your device is displayed in this window as well as the product documentation.

4.3.3 Certificates and approvals

Pressure Equipment Directive 2014/68/EU

The assembly has been manufactured according to good engineering practice as per Article 4, Paragraph 3 of the Pressure Equipment Directive 2014/68/EU and is therefore not required to bear the CE label.

Inspection certificate

A test certificate 3.1 in accordance with EN 10204 is supplied depending on the version (→ Product Configurator on the product page).

4.3.4 Manufacturer's address

Endress+Hauser Conducta GmbH+Co. KG
Dieselstraße 24
D-70839 Gerlingen

5 Installation

5.1 Installation conditions

5.1.1 Dimensions

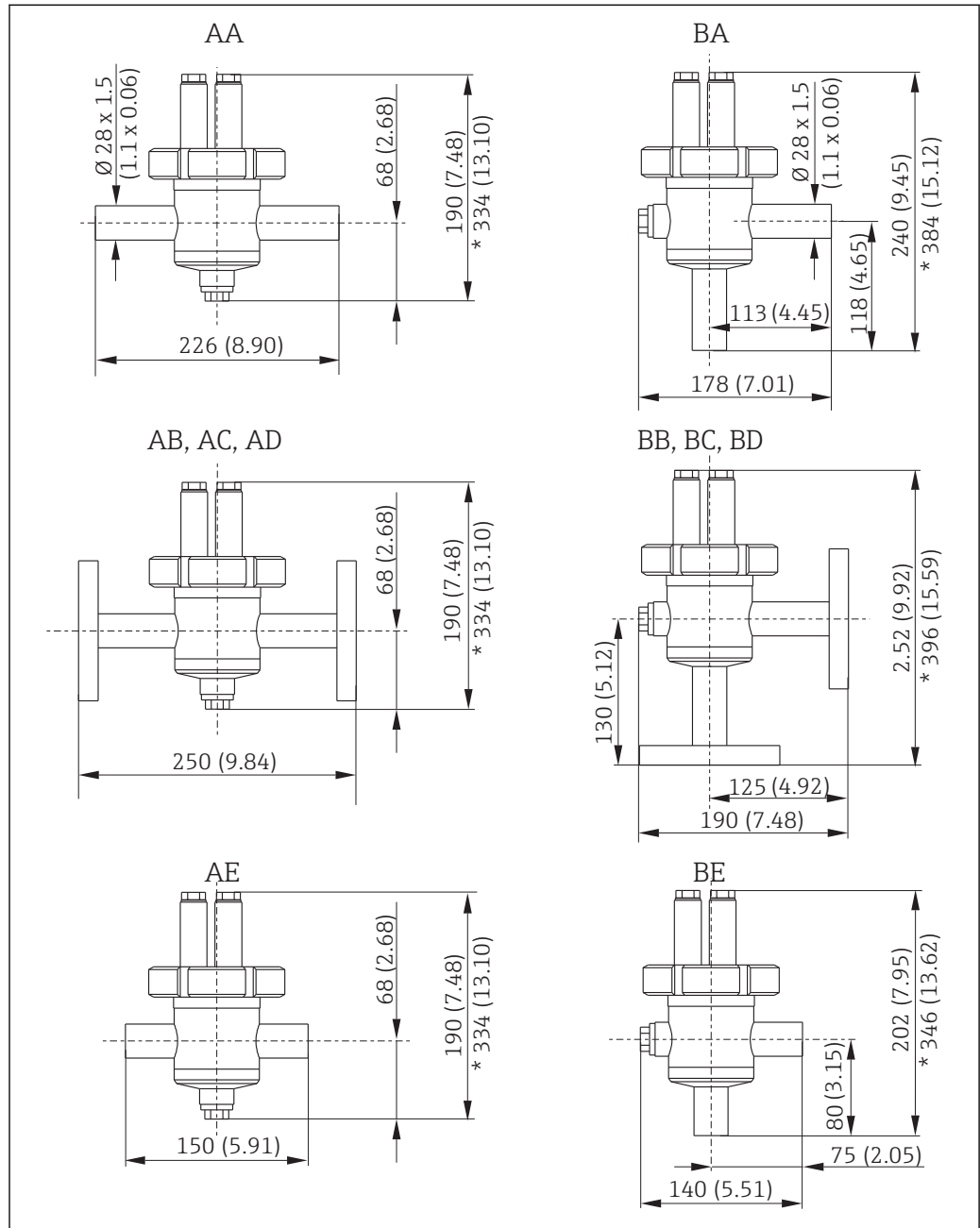

A0037603

3 Stainless steel version, dimensions in mm (in)

* With protection cover

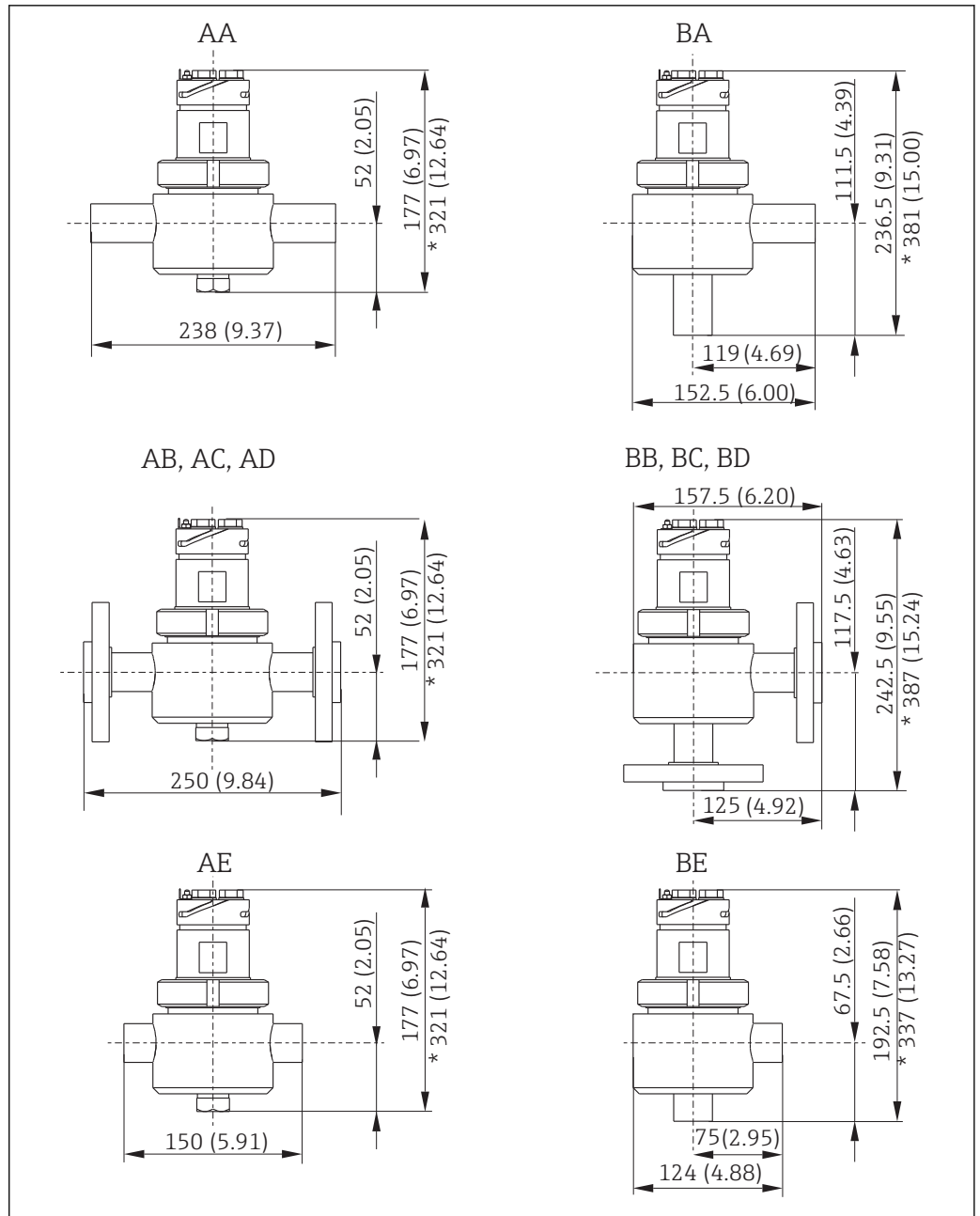

A0039014

4 PVDF version, dimensions in mm (in)

* With protection cover

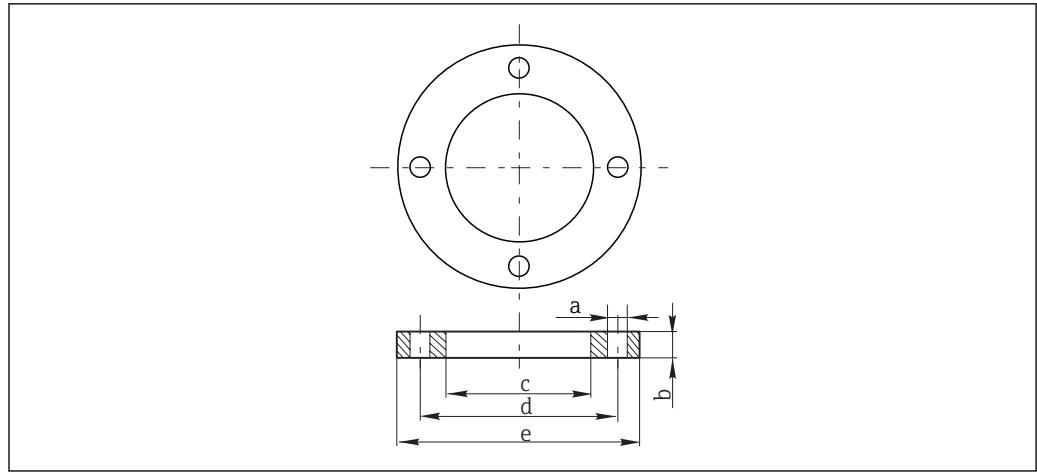

A0037606

5 Flange dimensions, → Table

	Stainless steel assembly version			PVDF assembly version		
	DN25 PN16	ANSI 1" 150 lbs	JIS 10K 25A	DN25 PN16	ANSI 1" 150 lbs	JIS 10K 25A
a [mm (in)]	14 (0.55)	16 (0.63)	19 (0.75)	14 (0.55)	16 (0.63)	19 (0.75)
b [mm (in)]	14 (0.55)	14 (0.55)	14 (0.55)	14 (0.55)	14 (0.55)	14 (0.55)
c [mm (in)]				42 (1.65)	42 (1.65)	42 (1.65)
d [mm (in)]	85(3.35)	79 (3.11)	90 (3.54)	85(3.35)	79 (3.11)	90 (3.54)
e [mm (in)]	115 (4.53)	108 (4.25)	125 (4.92)	115 (4.53)	115 (4.53)	125 (4.92)
Screws	M12	M12	M16	M12	M12	M16
Bore holes	4	4	4	4	4	4

5.1.2 Measuring system

A complete measuring system comprises:

- Flow assembly Flowfit CPA240
- 1-3 12 mm, pH/ORP combined sensors or temperature sensors, e.g. CPS11D, CPS12D
- 1-3 measuring cables, e.g. CYK10 or CPK9
- Transmitter, e.g. Liquiline CM442

Optional:

- Extension cable, e.g. CYK11
- Junction box, e.g. VBM

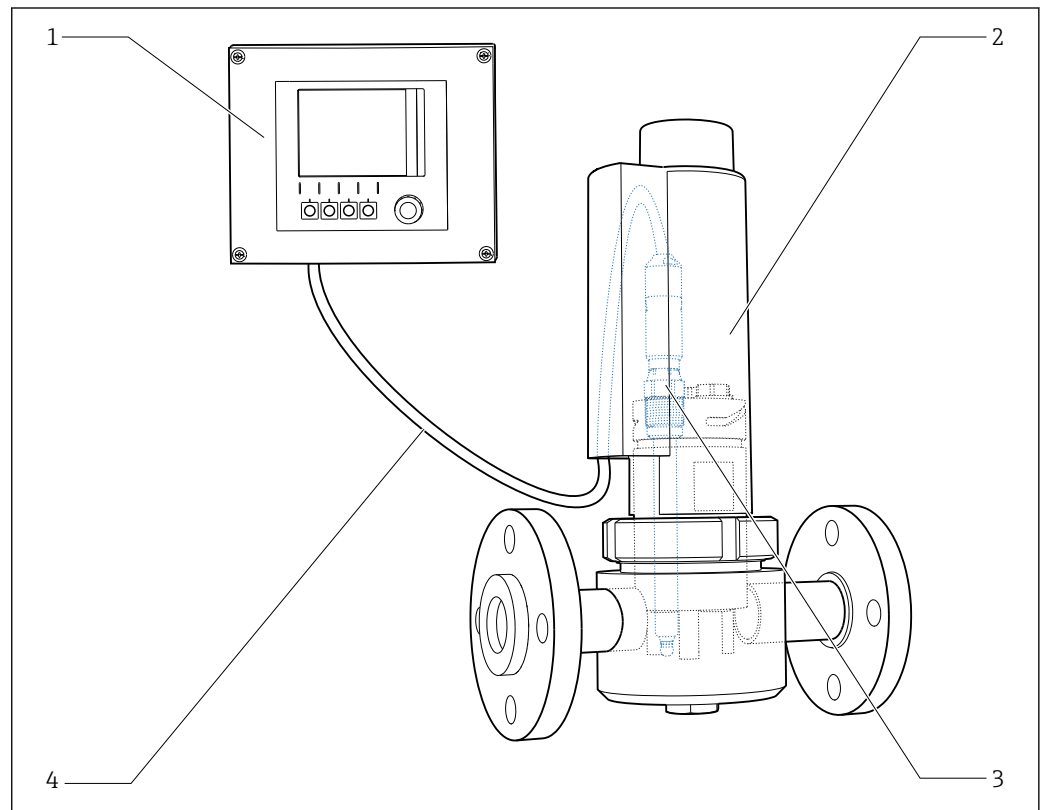

6 Example of a measuring system (process and process connections are not illustrated)

- 1 Transmitter CM442
- 2 Flow assembly Flowfit CPA240, here as PVDF version
- 3 pH sensor CPS11D
- 4 Sensor cable CYK10

5.2 Mounting the assembly

WARNING

Risk of injury from high pressure, high temperature or chemical hazards if process medium escapes!

- ▶ Do not exceed the permitted maximum process pressure.
- ▶ Prior to installing and removing the assembly, depressurize the system.
- ▶ Check that the sealing of the process seal is tight (no leaks).

Install the assembly at a location where it is not possible for the pipe to run dry. Installation in the bypass is preferable to installation in the process pipe, as the bypass line can be shut off without interrupting the process. It is then possible to perform measurements, sampling and sensor maintenance without having to interrupt the process.

1. Shut off the pipe and depressurize it.

2. Install the assembly in the pipe via the process connection. Make sure that either sensors or blanking plugs are mounted in the slots of the sensor holder.
3. Open the shut-off valve, and check that the sealing is tight (no leaks).

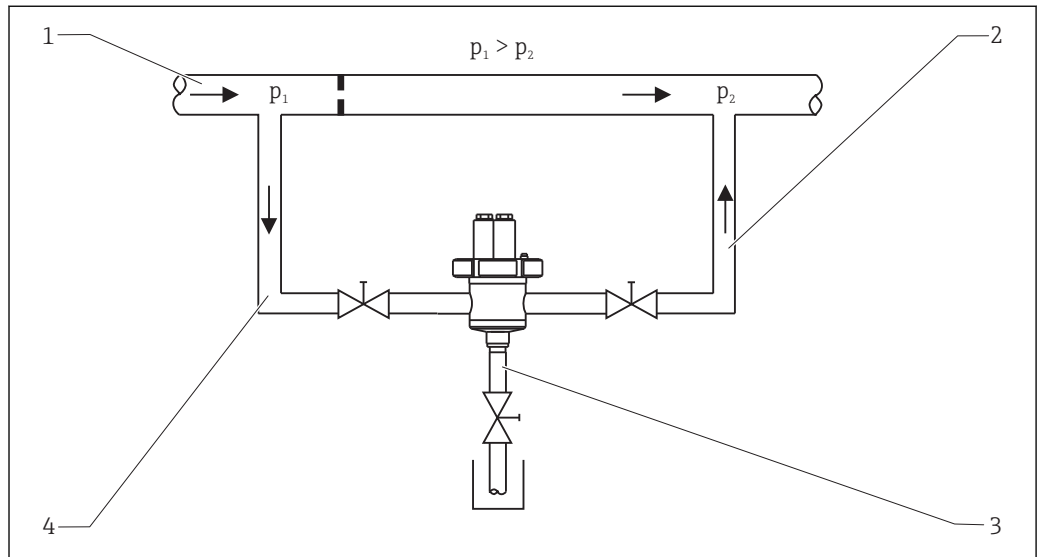

A0037617

7 Pipe bypass

- 1 Process pipe
- 2 Bypass line DN 25
- 3 Outlet, sampling line
- 4 Bypass line DN 25

An orifice plate in the process pipe creates the necessary pressure for medium to flow through the sample bypass.

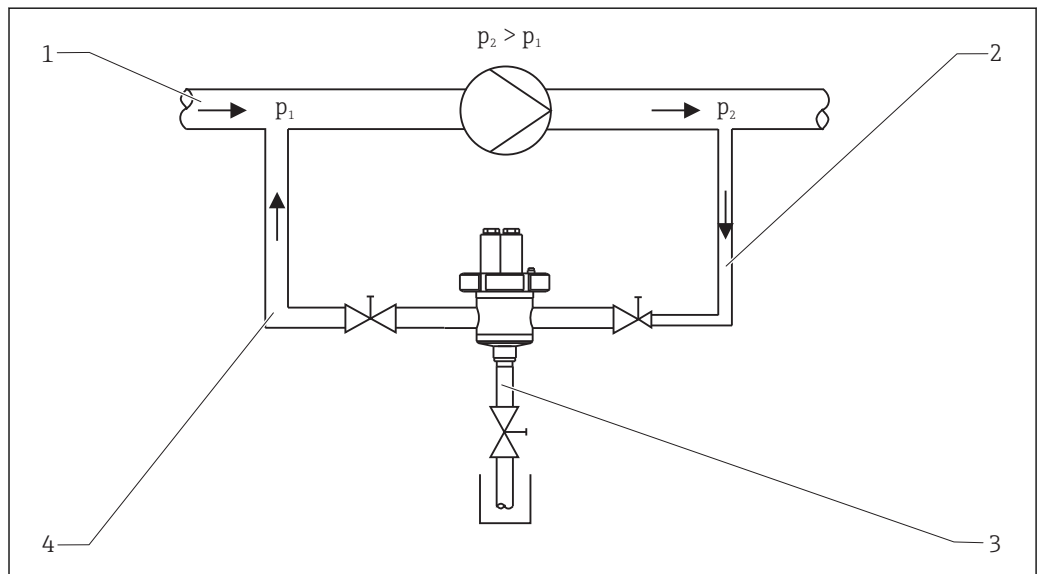

A0037619

8 Pump bypass

- 1 Process pipe
- 2 Bypass line DN 10
- 3 Outlet, sampling line
- 4 Bypass line DN 25

A pressure booster pump in the process pipe creates the necessary pressure for medium to flow through the sample bypass.

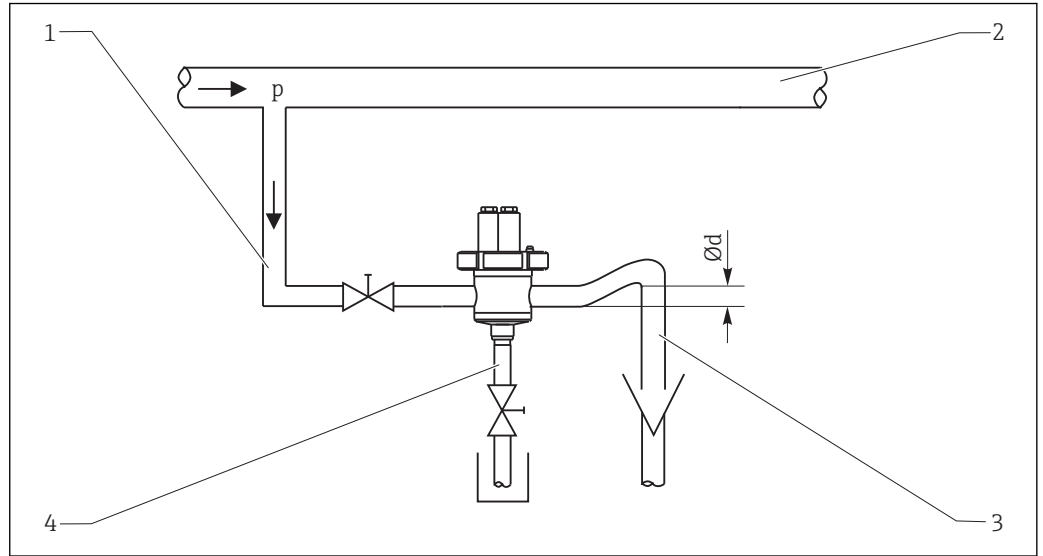

9 Sampling line, pipe branching off process pipe without pressure increase

- 1 Sampling line DN 25
- 2 Process pipe
- 3 Outlet
- 4 Sampling

5.3 Mounting the sensor

⚠ WARNING

Risk of injury from high pressure, high temperature or chemical hazards if process medium escapes!

- ▶ Do not exceed the permitted maximum process pressure.
- ▶ Prior to installing and removing the sensor, depressurize the system.

Install the sensors preferably after mounting the assembly.

i pH sensor with KCl supply line

Use the pressurized version of the CPY7B electrolyte supply vessel. Loop the KCl supply line in the assembly cover so that it is gently curved, but not bent or buckled.

1. Shut off the pipe and depressurize it.
- 2.

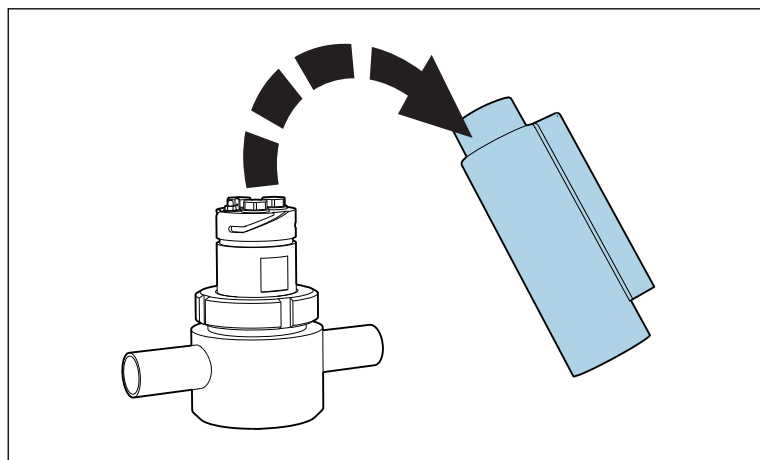

Remove the protection cover.

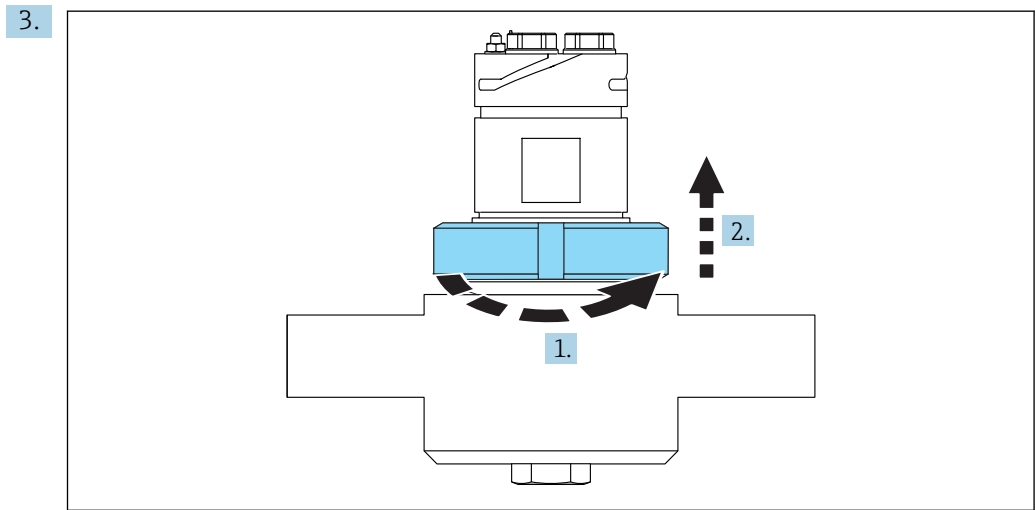

Loosen the union nut and remove it.

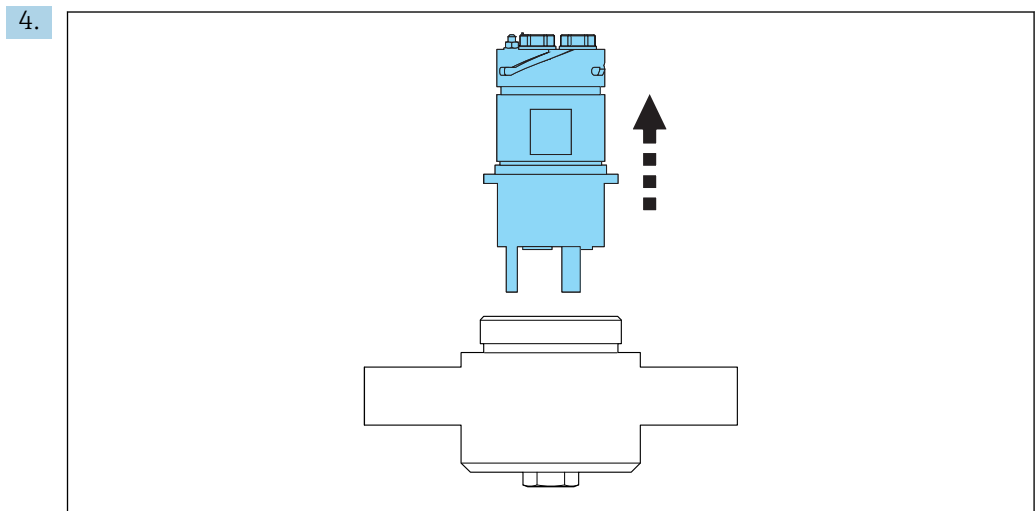

Remove the sensor holder.

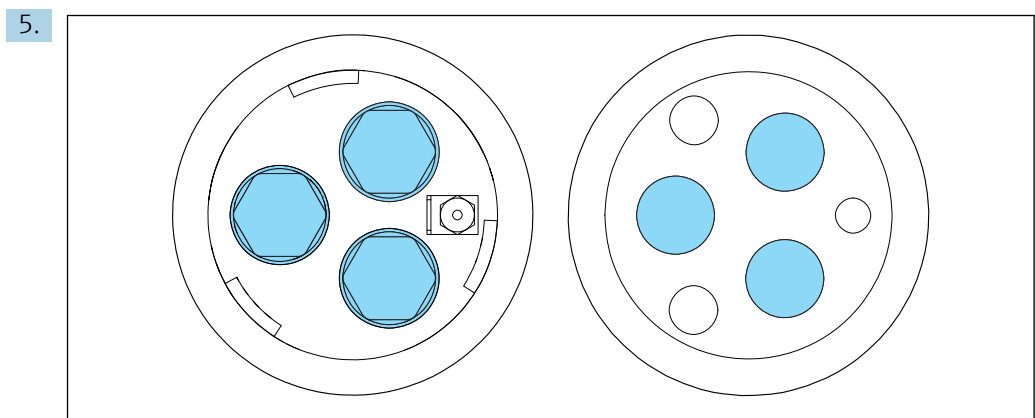

Remove the blanking plug with the seal (top) and stopper (bottom) from the sensor mounting slot.

6.

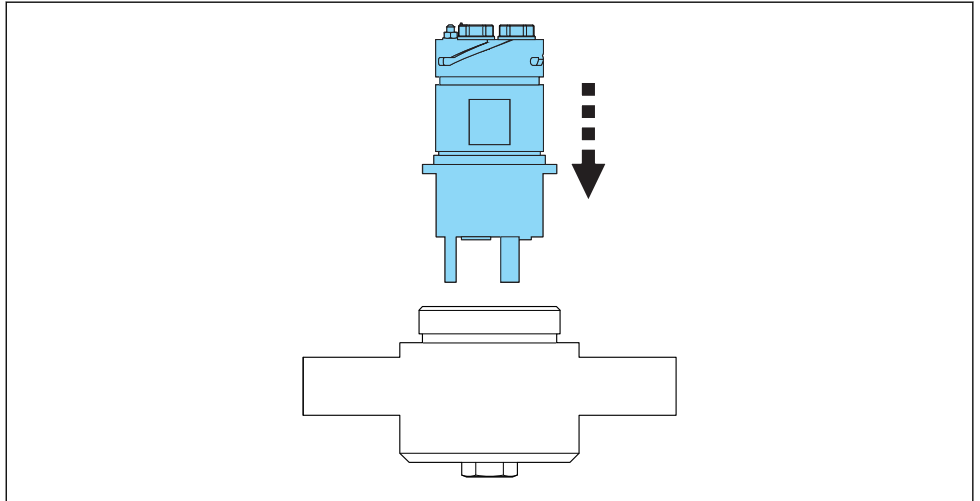

A0043217

Mount the sensor holder.

7.

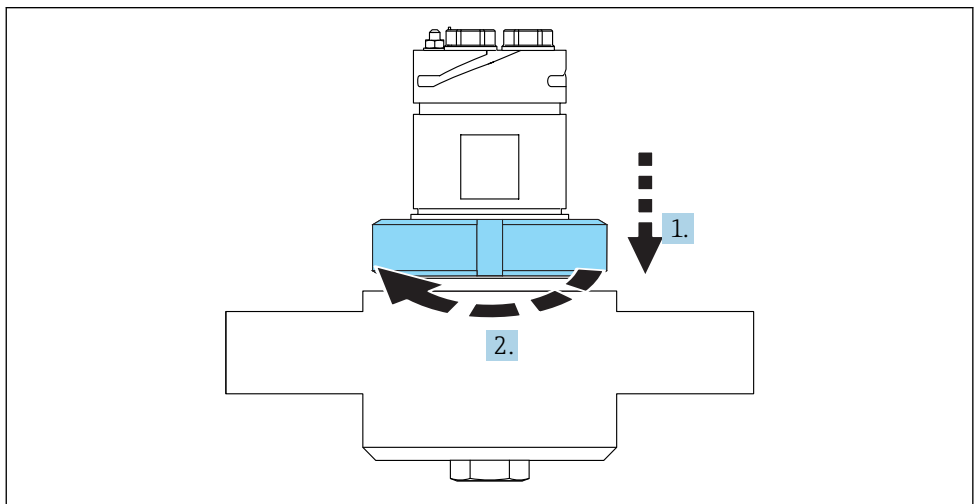

A0043216

Fit the union nut and tighten it.

8.

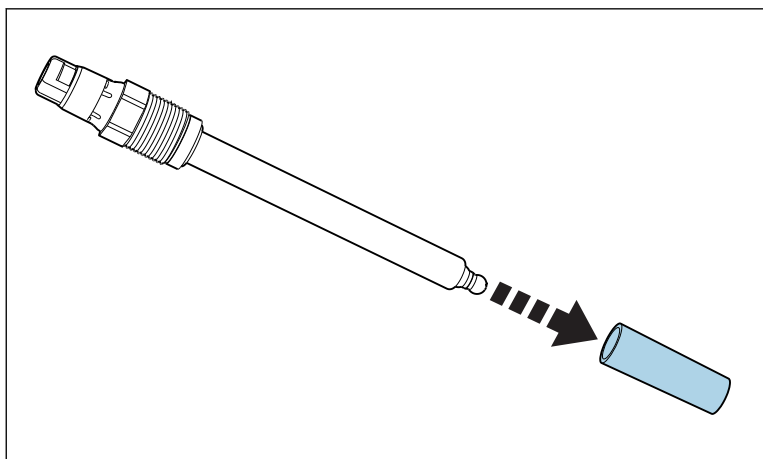

Remove the protection cap from the sensor.

9.

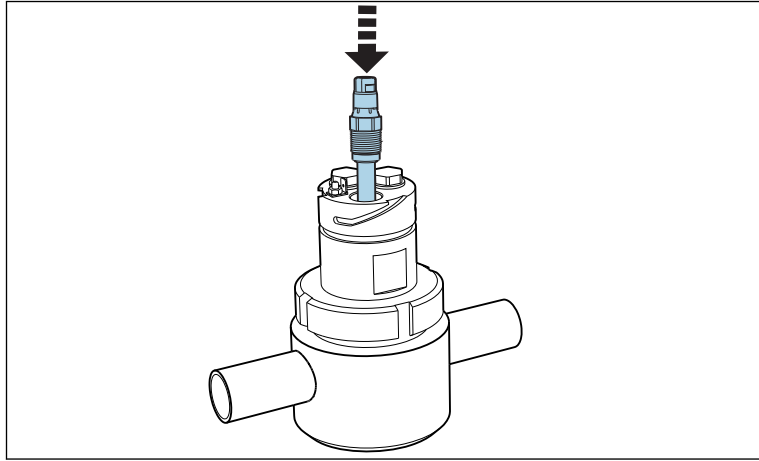

Screw in the sensor finger-tight, making sure that the seal and thrust collar are seated correctly.

10.

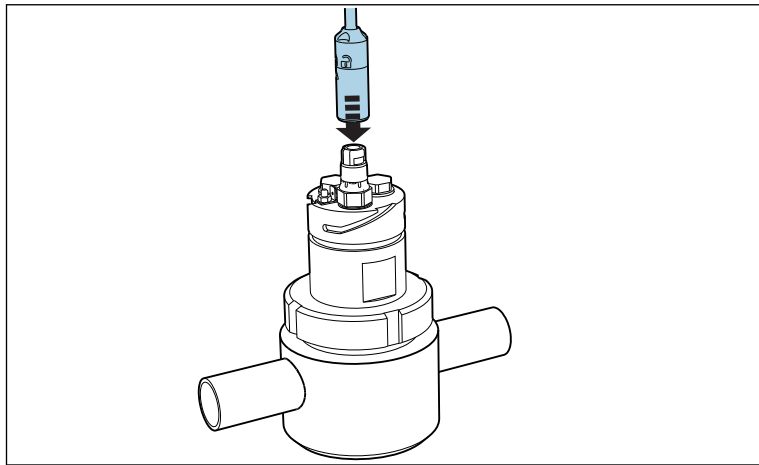

Connect the sensor cable.

11.

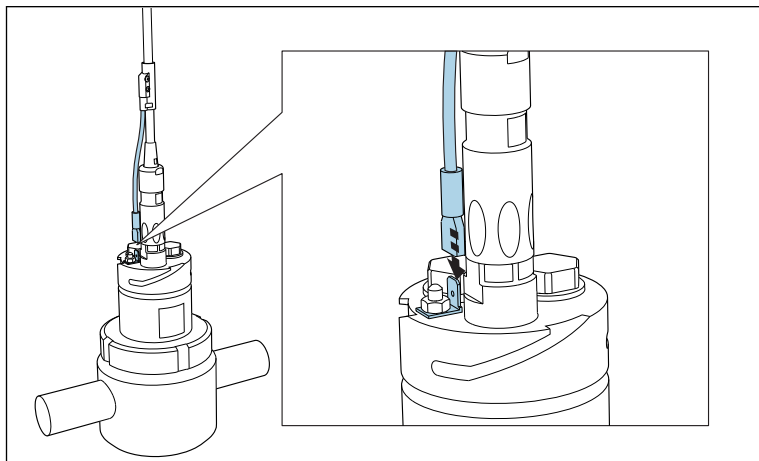

Only analog pH sensor with potential equalization:
Connect the PML.

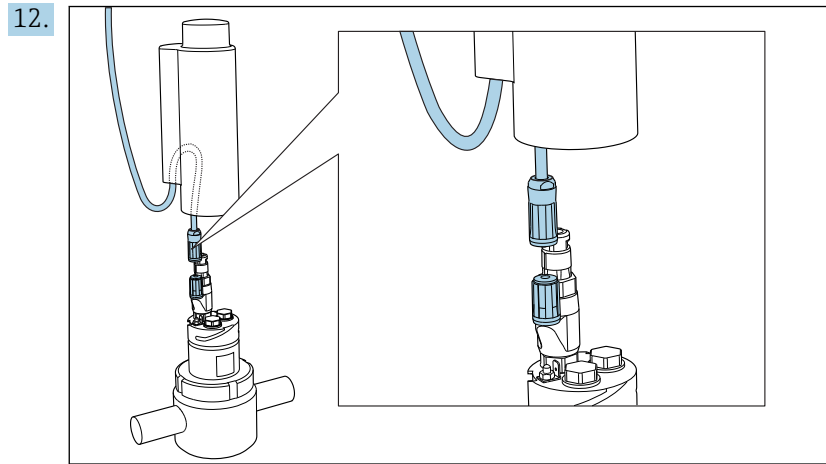

Only sensor with KCl supply line:

Guide the KCl supply line through the protection cover and connect it to the sensor. Loop the hose so that it is gently curved, but not bent or buckled!

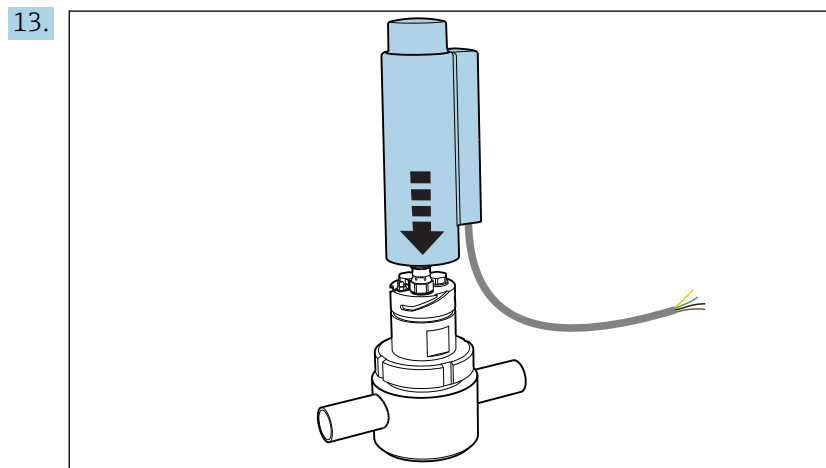

Guide the sensor cable through the protection cover and then fit the cover.

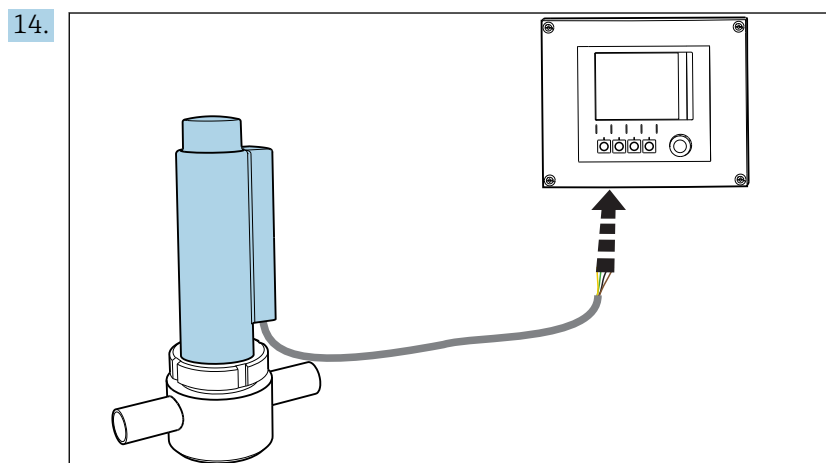

Connect the sensor cable to the transmitter.

15. Commission as described in the Operating Instructions for the sensor and transmitter.

The measuring point is now ready to measure.

5.4 Post-installation check

- Assembly undamaged?
- Is a sensor installed in the assembly?
- Have all the seals been checked to ensure they are leak-tight?

6 Maintenance

WARNING

Risk of injury if medium escapes

- ▶ Before each maintenance task, ensure that the process pipe is empty and rinsed.
- ▶ The assembly may contain residual medium; please rinse thoroughly before commencing work.

6.1 Cleaning the assembly

For stable and safe measurements:

- ▶ Clean the assembly and sensor regularly. The frequency and intensity of the cleaning process depend on the medium.

6.2 Cleaning agent

WARNING

Organic solvents containing halogens

Limited evidence of carcinogenicity! Dangerous for the environment with long-term effects!

- ▶ Do not use organic solvents that contain halogens.

WARNING

Thiocarbamide

Harmful if swallowed! Limited evidence of carcinogenicity! Possible risk of harm to the unborn child! Dangerous for the environment with long-term effects!

- ▶ Wear protective goggles, protective gloves and appropriate protective clothing.
- ▶ Avoid all contact with the eyes, mouth and skin.
- ▶ Avoid discharge into the environment.

The most common types of soiling and the cleaning agents used in each case are shown in the following table.

 Pay attention to the material compatibility of the materials to be cleaned.

Type of fouling	Cleaning agent
Greases and oils	Hot water or tempered (alkaline) agents containing surfactants or water-soluble organic solvents (e. g. ethanol)
Limescale deposits, metal hydroxide buildup, lyophobic biological buildup	Approx. 3% hydrochloric acid
Sulfide deposits	Mixture of 3% hydrochloric acid and thiocarbamide (commercially available)
Protein buildup	Mixture of 3% hydrochloric acid and pepsin (commercially available)
Fibers, suspended substances	Pressurized water, possibly surface-active agents
Light biological buildup	Pressurized water

- ▶ Choose a cleaning agent to suit the degree and type of soiling.

7 Repair

WARNING

Danger resulting from improper repair!

- ▶ Any damage to the assembly that compromises pressure safety must be repaired only by authorized and qualified personnel.
- ▶ Following each repair and maintenance task, check the assembly for leaks using appropriate procedures. Following this, the assembly must again comply with the specifications in the technical data.
- ▶ Replace all other damaged components immediately.

7.1 Spare parts

For more detailed information on spare parts kits, please refer to the [Spare Part Finding Tool](#) on the Internet.

7.2 Return

The product must be returned if repairs or a factory calibration are required, or if the wrong product was ordered or delivered. As an ISO-certified company and also due to legal regulations, Endress+Hauser is obliged to follow certain procedures when handling any returned products that have been in contact with medium.

To ensure the swift, safe and professional return of the device:

- ▶ Refer to the website www.endress.com/support/return-material for information on the procedure and conditions for returning devices.

7.3 Disposal

- ▶ Please observe local regulations!

8 Accessories

The following are the most important accessories available at the time this documentation was issued.

- ▶ For accessories not listed here, please contact your Service or Sales Center.

8.1 Sensors (selection)

Orbisint CPS11D

- pH sensor for process technology
- With dirt-repellent PTFE diaphragm

 Technical Information TI00028C

Ceraliquid CPS41D

pH electrode with ceramic junction and KCl liquid electrolyte

 Technical Information TI00079C

Orbisint CPS12D

ORP sensor for process technology

 Technical Information TI00367C

Ceraliquid CPS42D

ORP electrode with ceramic junction and KCl liquid electrolyte

 Technical Information TI00373C

Memosens CPS16D

- Combined pH/ORP sensor for process technology
- With dirt-repellent PTFE diaphragm
- With Memosens technology
- Product Configurator on the product page: www.endress.com/cps16D

 Technical Information TI00503C

8.2 Measuring cable

Memosens data cable CYK10

- For digital sensors with Memosens technology
- Product Configurator on the product page: www.endress.com/cyk10

 Technical Information TI00118C

Measuring cable CPK9

- Terminated measuring cable for connecting analog sensors with TOP68 plug-in head
- Selection in accordance with product structure
- Ordering information: Endress+Hauser sales office or www.endress.com.

8.3 KCl supply vessel

Electrolyte vessel CPY7B

- Storage container for KCl electrolyte, 200 ml
- Product Configurator on the product page: www.endress.com/cpy7b

 Operating Instructions BA00128C

9 Technical data

9.1 Environment

Ambient temperature range -10 to +70 °C (+10 to +160 °F)

Storage temperature -10 to +70 °C (+10 to +160 °F)

9.2 Process

Process temperature	PVDF version	0 to 120 °C (32 to 250 °F)
	Stainless steel version	-15 to 150 °C (5 to 300 °F), for all seals except EPDM -15 to 140 °C (5 to 280 °F), for EPDM seal

Process pressure	PVDF version	Max. 8 bar (116 psi) at 50 °C (122 °F)
	Stainless steel version	Max. 10 bar (145 psi)

Pressure-temperature ratings

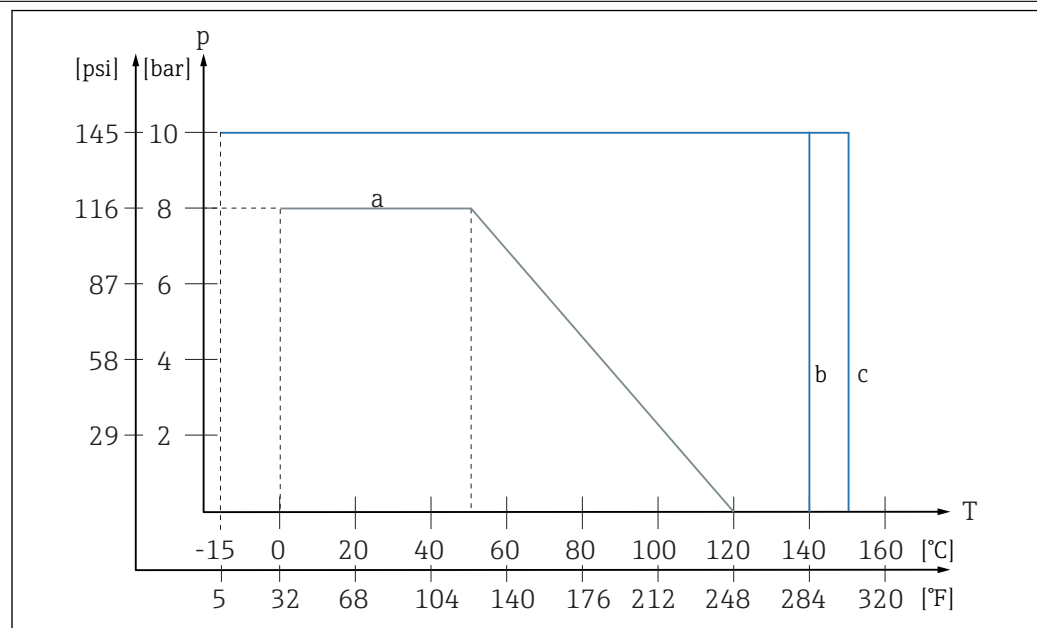

10 Pressure-temperature ratings

- a PVDF version
- b Stainless steel version with EPDM seal
- c Stainless steel version, all seals except EPDM

9.3 Mechanical construction

Dimensions → 10

Weight	Depends on version (material):	
	PVDF	2.0 kg (4.4 lbs)
	Stainless steel	3.0 to 4.5 kg (6.6 to 9.9 lbs)

Materials *In contact with medium, depending on version*

Flow vessel	PVDF / stainless steel 1.4404 (AISI 316L)
O-rings	EPDM / VITON / Chemraz / Fluoraz
Sensor holder	PVDF / stainless steel 1.4404 (AISI 316L)
Potential matching pin	Alloy C4 / tantalum / stainless steel 1.4401 (AISI 316)
Shock-protection stud	PVDF / stainless steel 1.4401 (AISI 316)
Dummy plug	PEEK

Not in contact with medium

Protection cap	PES
Union nut	Stainless steel 1.4301 (AISI 304)

Process connections	Depending on version:	
	■	Weld-in adapter, pipe DN 25 (Ø 28 x1.5)
	■	Flange DN 25 PN 16
	■	Flange ANSI 1" / 150 lbs
	■	Flange JIS 10K 25A
	■	NPT 1/2" thread

Sensor mounting slots	3 x Pg 13.5 for 12 mm sensors
	Sensor length: 120 mm

 Pay attention to the maximum flow velocities of the sensors.

Index

A

Accessories	23
Ambient temperature range	24

C

Certificates and approvals	9
Cleaning	21
Cleaning agent	21

D

Designated use	5
Dimensions	10
Disposal	22

I

Incoming acceptance	8
Installation	
Assembly	13
Check	20
Sensor	15
Installation conditions	10

M

Maintenance	21
Manufacturer's address	9
Materials	25
Measuring system	13
Mechanical construction	24

N

Nameplate	8
---------------------	---

O

Operational safety	5
Order code interpretation	8

P

Pressure-temperature ratings	24
Process connections	25
Process pressure	24
Process temperature	24
Product description	6
Product identification	8
Product page	8
Product safety	5

R

Repair	22
Return	22

S

Safety	
Operational safety	5
Product safety	5
Workplace safety	5
Safety instructions	5
Scope of delivery	8

Sensor mounting slots	25
Spare parts	22
Storage temperature	24
Symbols	4

T

Technical data	24
--------------------------	----

U

Use	5
---------------	---

W

Warnings	4
Weight	25
Workplace safety	5



71489229

www.addresses.endress.com
