

Safety Instructions

Micropilot

FMR50/51/52/53/54/56/57

4-20 mA HART

Ex nA IIC T6...T1 Gc

Ex ic IIC T6...T1 Gc



Document: XA01289F-B

Safety instructions for electrical apparatus for explosion-hazardous areas → 3

Document: XA01289F-B

Temperature tables → 17

Micropilot FMR50/51/52/53/54/56/57

4-20 mA HART

Table of contents

Associated documentation	4
Supplementary documentation	4
Manufacturer's certificates	4
Manufacturer address	4
Extended order code	4
Safety instructions: General	8
Safety instructions: Special conditions	8
Safety instructions: Installation	9
Temperature tables	11
Connection data	11

Associated documentation

This document is an integral part of the following Operating Instructions:

- BA01045F/00 (FMR50)
- BA01049F/00 (FMR51, FMR52)
- BA01050F/00 (FMR53, FMR54)
- BA01048F/00 (FMR56, FMR57)

Supplementary documentation

Explosion-protection brochure: CP00021Z/11

The Explosion-protection brochure is available:

- In the download area of the Endress+Hauser website:
www.endress.com -> Downloads -> Media Type: Documentation ->
 Documentation Type: Brochures and catalogs -> Text Search: CP00021Z
- On the CD for devices with CD-based documentation

Manufacturer's certificates

Certificate of Conformity

Certificate number:
TÜV 13.2010 X

Affixing the certificate number certifies conformity with the following standards (depending on the device version):

- ABNT NBR IEC 60079-0:2013
- ABNT NBR IEC 60079-11:2013
- ABNT NBR IEC 60079-15:2012

Manufacturer address

Endress+Hauser SE+Co. KG
 Hauptstraße 1
 79689 Maulburg, Germany
 Address of the manufacturing plant: See nameplate.

Extended order code

The extended order code is indicated on the nameplate, which is affixed to the device in such a way that it is clearly visible. Additional information about the nameplate is provided in the associated Operating Instructions.

Structure of the extended order code

FMR5x	-	*****	+	A*B*C*D*E*F*G*..
<i>(Device type)</i>		<i>(Basic specifications)</i>		<i>(Optional specifications)</i>

* = Placeholder
 At this position, an option (number or letter) selected from the specification is displayed instead of the placeholders.

Basic specifications

The features that are absolutely essential for the device (mandatory features) are specified in the basic specifications. The number of positions depends on the number of features available. The selected option of a feature can consist of several positions.

Optional specifications

The optional specifications describe additional features for the device (optional features). The number of positions depends on the number of features available. The features have a 2-digit structure to aid identification (e.g. JA). The first digit (ID) stands for the feature group and consists of a number or a letter (e.g. J = Test, Certificate). The second digit constitutes the value that stands for the feature within the group (e.g. A = 3.1 material (wetted parts), inspection certificate).

More detailed information about the device is provided in the following tables. These tables describe the individual positions and IDs in the extended order code which are relevant to hazardous locations.

Extended order code: Micropilot



The following specifications reproduce an extract from the product structure and are used to assign:

- This documentation to the device (using the extended order code on the nameplate).
- The device options cited in the document.

Device type

FMR50, FMR51, FMR52, FMR53, FMR54, FMR56, FMR57

Basic specifications

Position 1, 2 (Approval)		
Selected option		Description
FMR5x	MG ^{1) 2)}	INMETRO Ex nA IIC T6...T1 Gc
	MH ³⁾	INMETRO Ex ic IIC T6...T1 Gc

- 1) Combination with Position 4 (Display, Operation) = L, M, N in connection with Position 3 (Power Supply, Output) = A is not allowed.
- 2) The designation changes in connection with Position 4 (Display, Operation) = L, M, N and Position 3 (Power Supply, Output) = B, C, K, L: Ex nA [ia Ga] IIC T6...T1 Gc
- 3) The designation changes in connection with Position 4 (Display, Operation) = L, M, N and Position 3 (Power Supply, Output) = B, C: Ex ic [ia Ga] IIC T6...T1 Gc

Position 3 (Power Supply, Output)		
Selected option		Description
FMR5x	A	2-wire, 4-20 mA HART
	B	2-wire, 4-20 mA HART, switch output (PFS)
	C	2-wire, 4-20 mA HART, 4...20 mA
	K ¹⁾	4-wire, 90-253 VAC; 4-20 mA HART
	L ¹⁾	4-wire, 10,4-48 VDC; 4-20 mA HART

- 1) Only in connection with Position 1, 2 (Approval) = MG

Position 4 (Display, Operation)		
Selected option		Description
FMR5x	A	Without, via communication
	C	SD02, 4-line, push buttons + data backup function
	E	SD03, 4-line, illum., touch control + data backup function
	L ^{1) 2)}	Prepared for display FHX50 + M12 connection
	M ^{1), 2)}	Prepared for display FHX50 + custom connection
	N ^{2) 3)}	Prepared for display FHX50 + NPT1/2"

- 1) In connection with Position 5 (Housing) = A: Observe the specifications in the "Overvoltage protection" and "Temperature tables" chapters!
- 2) Only in connection with Position 1, 2 (Approval) = MH
- 3) Only in connection with Position 5 (Housing) = B, C

Position 5 (Housing)		
Selected option		Description
FMR5x	A ¹⁾	GT19 dual compartment, plastics PBT
	C	GT20 dual compartment, Alu coated
FMR51-54 FMR57	B	GT18 dual compartment, 316L

1) Only in connection with Position 1, 2 (Approval) = MH

Position 6 (Electrical Connection)		
Selected option		Description
FMR5x	A	Gland M20, IP66/68 NEMA4X/6P
	B	Thread M20, IP66/68 NEMA4X/6P
	C	Thread G1/2, IP66/68 NEMA4X/6P
	D	Thread NPT1/2, IP66/68 NEMA4X/6P
	I ^{1) 2)}	Plug M12, IP66/68 NEMA4X/6P
	M ^{1) 2)}	Plug 7/8", IP66/68 NEMA4X/6P

1) Only in connection with Position 1, 2 (Approval) = MH

2) Only in connection with Position 3 (Power Supply, Output) = A

Position 7, 8 (Antenna)		
Selected option		Description
FMR50	BM	Horn 40 mm/1½", PVDF encapsulated, -40...130°C
	BN	Horn 80 mm/3", PP cladded, -40...80°C
	BR	Horn 100 mm/4", PP cladded, -40...80°C
FMR51	Bx	Horn (different sizes)
FMR52	BO	Horn 50 mm/2", -40...200°C ¹⁾ , -196...200°C ²⁾ , flush mount
	BP	Horn 80 mm/3", -40...200°C ¹⁾ , -196...200°C ²⁾ , flush mount
FMR53	Cx	Rod (different sizes)
FMR54	Ax	Without Horn
	Bx	Horn (different sizes)
	Dx	Planar (different sizes)
FMR56	BN	Horn 80 mm/3", PP cladded, -40...80°C
	BR	Horn 100 mm/4", PP cladded, -40...80°C
FMR57	Bx	Horn (different sizes)
	Fx	Parabolic (different sizes)

1) In connection with Position 5 (Housing) = A

2) Only in connection with Position 5 (Housing) = B, C

Position 9, 10 (Seal)		
Selected option		Description
FMR51	A5	Viton GLT, -40...150°C
	C1	Kalrez, -20...150°C
	D2	Graphite, -196...450°C (HT)
	D3	Graphite, -40...250°C (XT)
FMR54	A7	Viton, -20...150°C (Planar)
	A8	Viton, -40...200°C
	B4	EPDM, -40...150°C
	C2	Kalrez, -20...200°C, conductive media max. 150°C
	D1	Graphite, -196...280°C (XT)
	D2	Graphite, -196...400°C (HT)
FMR57	A6	Viton GLT, -40...200°C
	D4	Graphite, -40...400°C (HT)

Position 11-13 (Process Connection)		
Selected option		Description
FMR51-54 FMR57	Axx Cxx Kxx	Flange (different sizes)
FMR50	GGF RGF	Thread, PVDF
	UAE	Mounting bracket
	XR0	Connection, without flange/mounting bracket
	XxG	Slip on flange (different sizes)
FMR51	Pxx	Flange (different sizes)
	Rxx	Thread
	Txx	Tri-Clamp
FMR52	Mxx	Slotted-nut
	Txx	Tri-Clamp
FMR53	RxJ	Thread, 316L
	RxF	Thread, PVDF
FMR56	UAE	Mounting bracket
	XR0	Connection, without flange/mounting bracket
	XxG	Slip on flange (different sizes)
FMR57	RxJ	Thread, 316L
	Xxj	Align. device (different sizes)

Optional specifications

ID Jx (Test, Certificate)	
Selected option	Description
FMR51 ¹⁾ JN ³⁾ FMR52 FMR54 ²⁾	Ambient temperature transmitter -50°C

- 1) Only in connection with Position 9, 10 (Seal) = D2
- 2) Only in connection with Position 9, 10 (Seal) = D1, D2
- 3) Only in connection with Position 1, 2 (Approval) = MH and Position 5 (Housing) = B, C

ID Nx, Ox (Accessory Mounted)	
Selected option	Description
FMR5x NA ¹⁾	Overvoltage protection
NF ²⁾	Bluetooth
FMR51 OW FMR57	Horn protection, PTFE, no airpurge possible

- 1) Only in connection with Position 3 (Power Supply, Output) = A, B, C
- 2) Only in connection with Position 4 (Display, Operation) = C, E

Safety instructions: General

- Staff must meet the following conditions for mounting, electrical installation, commissioning and maintenance of the device:
 - Be suitably qualified for their role and the tasks they perform
 - Be trained in explosion protection
 - Be familiar with national regulations
- Install the device according to the manufacturer's instructions and national regulations.
- Do not operate the device outside the specified electrical, thermal and mechanical parameters.
- Only use the device in media to which the wetted materials have sufficient durability.
- Avoid electrostatic charging:
 - Of plastic surfaces (e.g. housing, sensor element, special varnishing, attached additional plates, ..)
 - Of isolated capacities (e.g. isolated metallic plates)
- Modifications to the device can affect the explosion protection and must be carried out by staff authorized to perform such work by Endress+Hauser.
- Refer to the temperature tables for the relationship between the permitted ambient temperature for the sensor and/or transmitter, depending on the range of application and the temperature class.

**Safety instructions:
Special conditions**

Permitted ambient temperature range at the electronics housing:
 $-40\text{ °C} \leq T_a \leq +80\text{ °C}$

Optional specification, ID Jx (Test, Certificate) = JN

Permitted ambient temperature range at the electronics housing:
 $-50\text{ °C} \leq T_a \leq +80\text{ °C}$

- Observe the information in the temperature tables.
- In the case of process connections made of polymeric material or with polymeric coatings, avoid electrostatic charging of the plastic surfaces.
- To avoid electrostatic charging: Do not rub surfaces with a dry cloth.
- In the event of additional or alternative special varnishing on the housing or other metal parts or for adhesive plates:
 - Observe the danger of electrostatic charging and discharge.
 - Do not install in the vicinity of processes ($\leq 0.5\text{ m}$) generating strong electrostatic charges.

Basic specification, Position 5 (Housing) = A

Avoid electrostatic charging of the housing (e.g. friction, cleaning, maintenance, strong medium flow).

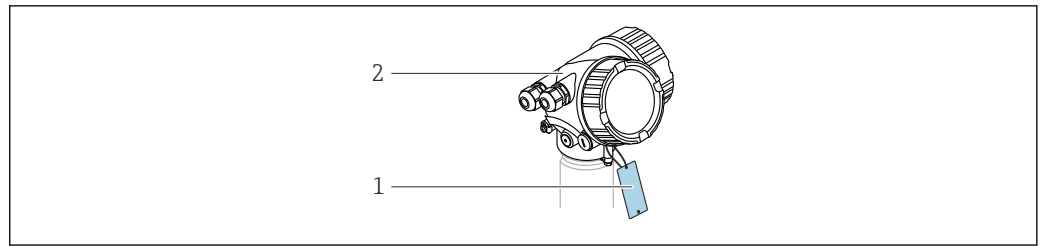

A0032146

1

- 1 Isolated capacitance:
with one metal plate: $\leq 3 \text{ pF}$ (permitted in all areas for Equipment Groups II and III)
with two to three metal plates: $\leq 10 \text{ pF}$ (not permitted in Zone 0 and for Equipment Group IIC)
- 2 Housing

Device type FMR50, FMR52, FMR53, FMR54 (planar, enamel), FMR56

An antenna coated with non-conductive material can be used if avoiding electrostatic charging (e.g. through friction, cleaning, maintenance, strong medium flow).

Device type FMR51, FMR57 and Optional specification, ID Nx, Ox (Accessory Mounted) = OW

An antenna coated with non-conductive material can be used if avoiding electrostatic charging (e.g. through friction, cleaning, maintenance, strong medium flow).

Safety instructions: Installation

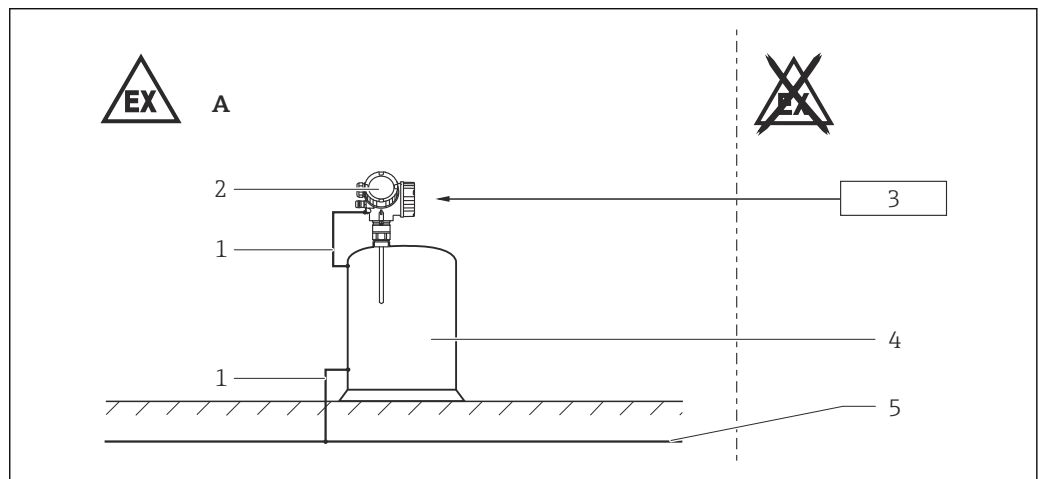

A0022629

2

- A Zone 2
- 1 Potential equalization line
- 2 Electronic insert
- 3 Ex ic: Certified associated apparatus; Ex nA: Supply depending upon equipment version
- 4 Tank; Zone 2
- 5 Potential equalization

- After aligning (rotating) the housing, retighten the fixing screw (see Operating Instructions).
- Install the device to exclude any mechanical damage or friction during the application. Pay particular attention to flow conditions and tank fittings.
- After mounting and connecting the antenna, ingress protection of the housing must be at least IP65.
- Perform the following to achieve the degree of protection:
 - Screw the cover tight.
 - Mount the cable entry correctly.
- Continuous service temperature of the connecting cable: -40 °C to $\geq +85 \text{ °C}$; in accordance with the range of service temperature taking into account additional influences of the process conditions ($T_{a,\min}$), ($T_{a,\max} + 20 \text{ K}$).

Optional specification, ID Jx (Test, Certificate) = JN

Continuous service temperature of the connecting cable: -50 °C to $\geq +85\text{ °C}$; in accordance with the range of service temperature taking into account additional influences of the process conditions ($T_{a,\min}$), ($T_{a,\max} + 20\text{ K}$).

Basic specification, Position 3 (Power Supply, Output) = K

Connect the protective ground to the device.

Basic specification, Position 4 (Display, Operation) = N

Observe the requirements according to IEC/EN 60079-14 for conduit systems and the wiring- and installation instructions of the suitable Safety Instructions (XA). In addition, observe national regulations and standards for conduit systems.

Intrinsic safety

Ex ic

Basic specification, Position 1, 2 (Approval) = MH

- The device is only suitable for connection to certified, intrinsically safe equipment with explosion protection Ex ic.
- If the conditions $U_i > U_o$, ($I_i > I_o$), $C_a > C_i + C_{\text{cable}}$ and $L_a > L_i + L_{\text{cable}}$ are met, the energy-limited installation concept (Ex ic) allows energy-limited devices or associated energy-limited devices to be connected according to the entity concept.
- The intrinsically safe input power circuit of the device is isolated from ground. If the device is only equipped with one input, the dielectric strength of the input is at least $500\text{ V}_{\text{rms}}$. If the device is equipped with more than one input, the dielectric strength of each individual input to ground is at least $500\text{ V}_{\text{rms}}$, and the dielectric strength of the inputs vis-à-vis one another is also at least $500\text{ V}_{\text{rms}}$.
- Observe the pertinent guidelines when interconnecting intrinsically safe circuits.
- The device can be connected to the Endress+Hauser FXA291 service tool: refer to the Operating Instructions and specifications in the "Overvoltage protection" chapter.
- The device can be equipped with the Bluetooth® module: refer to the Operating Instructions and specifications in the "Bluetooth® module" chapter.

Non-sparking

Ex nA

Basic specification, Position 1, 2 (Approval) = MG

- In potentially explosive atmospheres:
 - Do not disconnect electrical connections when energized.
 - Do not connect the service tool (e.g. FXA291).
- The device can be equipped with the Bluetooth® module: refer to the Operating Instructions and specifications in the "Bluetooth® module" chapter.

Basic specification, Position 5 (Housing) = A

The housing is not approved for Ex nA explosion protection.

Cable specification

Without *Optional specification, ID Nx, Ox (Accessory Mounted) = NA*

(*Overvoltage protection Type OVP10 and Type OVP20*)

<i>Basic specification, Position 3 (Power Supply, Output)</i>	Cross section connecting wire	Stripped insulation
A, B, C	0.5 to 2.5 mm ²	10 mm

With *Optional specification, ID Nx, Ox (Accessory Mounted) = NA*

(*Overvoltage protection Type OVP10 and Type OVP20*)

<i>Basic specification, Position 3 (Power Supply, Output)</i>	Cross section connecting wire	Tightening torque of terminal screw	Stripped insulation
A, B, C	0.2 to 2.5 mm ²	0.35 to 0.4 Nm	5 mm

Potential equalization

Integrate the device into the local potential equalization.

Overvoltage protection

Basic specification, Position 3 (Power supply, Output) = A, B, C

- If an overvoltage protection against atmospheric over voltages is required: no other circuits may leave the housing during normal operation without additional measures.
- For installations which require overvoltage protection to comply with national regulations or standards, install the device using overvoltage protection (e.g. HAW56x from Endress+Hauser).
- Observe the safety instructions of the overvoltage protection.

*Optional specification, ID Nx, Ox (Accessory Mounted) = NA
(Overvoltage protection Type OVP10 and Type OVP20)*

The intrinsically safe input power circuit of the device is isolated from ground. If the device is only equipped with one input, the dielectric strength of the input is at least 290 V_{rms}. If the device is equipped with more than one input, the dielectric strength of each individual input to ground is at least 290 V_{rms}, and the dielectric strength of the inputs vis-à-vis one another is also at least 290 V_{rms}.

Bluetooth® module

Optional specification, ID Nx, Ox (Accessory Mounted) = NF

- With Bluetooth® module installed: Use of external hardware not allowed (e.g. external display, service interface).
- The intrinsically safe input power circuit of the Bluetooth® module is isolated from ground.

Temperature tables

→ 18

Connection data

Cable entry: Connection compartment

Ex ic

Basic specification, Position 1, 2 (Approval) = MH

Not relevant.

Ex nA

Basic specification, Position 1, 2 (Approval) = MG

Cable gland: Basic specification, Position 6 (Electrical Connection) = A

Basic specification, Position 5 (Housing) = B, C

preferably for Position 5 (Housing) = B

Thread	Clamping range	Material	Sealing insert	O-ring
M20x1,5	ø 7 to 12 mm	1.4404	NBR	EPDM (ø 17x2)

preferably for Position 5 (Housing) = C

Thread	Clamping range	Material	Sealing insert	O-ring
M20x1,5	ø 8 to 10.5 mm ¹⁾ (ø 6.5 to 13 mm) ²⁾	Ms, nickel-plated	LSR (Silicone)	EPDM (ø 17x2)

1) Standard

2) Separate clamping inserts available

- i
 - The tightening torque refers to cable glands installed by the manufacturer:
 - Recommended: 3.5 Nm
 - Maximum: 10 Nm
 - This value may be different depending on the type of cable. However, the maximum value must not be exceeded.
- Only suitable for fixed installation. The operator must pay attention to a suitable strain relief of the cable.
- The cable glands are suitable for a low risk of mechanical danger (4 Joule) and must be mounted in a protected position if larger impact energy levels are expected.
- To maintain the ingress protection of the housing: Install the housing cover, cable glands and blind plugs correctly.

Cable entry: Electronics compartment

Not relevant.

Terminals

Optional specification, ID Nx, Ox (Accessory Mounted) = NA
(Overvoltage protection Type OVP10 and Type OVP20)

When using the internal overvoltage protection: No changes to the connection values.

Optional specification, ID Nx, Ox (Accessory Mounted) = NF

When using the Bluetooth® module: No changes to the connection values.

Ex ic

Basic specification, Position 1, 2 (Approval) = MH

Power supply and signal circuit with protection type: intrinsic safety Ex ic IIC, Ex ic IIB.

Basic specification, Position 3 (Power Supply, Output) = A

Terminal 1 (+), 2 (-)
Power supply $U_i = 35 \text{ V}$ $I_i = \text{not applicable}$ (current-controlled circuit) $P_i = \text{not applicable}$ effective inner inductance $L_i = 0$ effective inner capacitance $C_i = 12 \text{ nF}$

Basic specification, Position 3 (Power Supply, Output) = B

Terminal 1 (+), 2 (-)	Terminal 3 (+), 4 (-)
Power supply $U_i = 35 \text{ V}$ $I_i = \text{not applicable}$ (current-controlled circuit) $P_i = \text{not applicable}$ effective inner inductance $L_i = 0$ effective inner capacitance $C_i = 5 \text{ nF}$	Switch output (PFS) $U_i = 35 \text{ V}$ $I_i = \text{not applicable}$ (current-controlled circuit) $P_i = 1 \text{ W}$ effective inner inductance $L_i = 0$ effective inner capacitance $C_i = 6 \text{ nF}$

Basic specification, Position 3 (Power Supply, Output) = C

Terminal 1 (+), 2 (-)	Terminal 3 (+), 4 (-)
Power supply $U_i = 30 \text{ V}$ $I_i = \text{not applicable}$ (current-controlled circuit) $P_i = \text{not applicable}$ effective inner inductance $L_i = 0$ effective inner capacitance $C_i = 30 \text{ nF}$	Output 4 to 20 mA $U_i = 30 \text{ V}$ $I_i = \text{not applicable}$ $P_i = \text{not applicable}$ effective inner inductance $L_i = 0$ effective inner capacitance $C_i = 30 \text{ nF}$

Service interface (CDI)

Taking the following values into consideration, the device can be connected to the certified Endress+Hauser FXA291 service tool or a similar interface:

Service interface													
$U_i = 7.3 \text{ V}$ effective inner inductance $L_i = \text{negligible}$ effective inner capacitance $C_i = \text{negligible}$													
$U_o = 7.3 \text{ V}$ $I_o = 100 \text{ mA}$ $P_o = 160 \text{ mW}$													
$L_o \text{ (mH)} =$	5.00	2.00	1.00	0.50	0.20	0.15	0.10	0.05	0.02	0.01	0.005	0.002	0.001
$C_o \text{ (}\mu\text{F)}^{1) =}$	0.73	1.20	1.60	2.00	2.60	-	3.20	4.00	5.50	7.30	10.00	12.70	12.70
$C_o \text{ (}\mu\text{F)}^{2) =}$	-	0.49	0.90	1.40	-	2.00	-	-	-	-	-	-	-

1) Values according to PTB "ispark" program

2) Values according to ABNT NBR IEC 60079-25, Annex C

Ex nA

Basic specification, Position 1, 2 (Approval) = MG

Power supply and signal circuit with protection type: not intrinsically safe.

Basic specification, Position 3 (Power Supply, Output) = A

Terminal 1 (+), 2 (-)
Power supply
$U_N = 35 \text{ V}_{\text{DC}}$
$I_N = 4 \text{ to } 20 \text{ mA}$

Basic specification, Position 3 (Power Supply, Output) = B

The power consumption of I/O modules with passive PFS output can be limited for certain applications.

- Recommended: Power consumption = 1 W. This is obtained for a supply voltage at the terminals of 27 V_{DC} .
- For higher supply voltages (U_{max}): Insert a serial resistance (R_V) in order to limit the power consumption, see table below.

Table for the PFS serial resistance (R_V):

Power consumption	1.0 W
Total power consumption	1.88 W
Internal resistance R_i	760 Ω

U_{\max} [V]	R_V min
35	205 Ω
34	177 Ω
33	150 Ω
32	122 Ω
31	95 Ω
30	67 Ω
29	39 Ω
28	12 Ω
27	0 Ω

 For values associated with a higher or lower internal power consumption please contact Endress+Hauser.

Terminal 1 (+), 2 (-)	Terminal 3 (+), 4 (-)
Power supply $U_N = 35 V_{DC}$ $U_m = 250 V$ $I_{\max} = 22 \text{ mA}$	Switch output (PFS) $U_N = 35 V_{DC}$ $U_m = 250 V$

Basic specification, Position 3 (Power Supply, Output) = C

Terminal 1 (+), 2 (-)	Terminal 3 (+), 4 (-)
Power supply $U_N = 30 V_{DC}$ $I_{\max} = 22 \text{ mA}$	Output 4 to 20 mA $U_N = 30 V_{DC}$ $I_{\max} = 22 \text{ mA}$

Basic specification, Position 3 (Power Supply, Output) = K

Terminal 1 (+), 2 (-)	Terminal 3 (+), 4 (-)
Power supply $U_N = 253 V_{AC}; 50/60 \text{ Hz}$ $U_m = 250 V$ $I_N = 25 \text{ mA}$ $I_{\max} = 160 \text{ mA}$	Output 4 to 20 mA $U_N = 22 V_{DC}$ $U_m = 250 V$ $I_{\max} = 22 \text{ mA}$

Basic specification, Position 3 (Power Supply, Output) = L

Terminal 1 (+), 2 (-)	Terminal 3 (+), 4 (-)
Power supply $U_N = 48 V_{DC}$ $U_m = 250 V$ $I_N = 112 \text{ mA}$ $I_{\max} = 300 \text{ mA}$	Output 4 to 20 mA $U_N = 22 V_{DC}$ $U_m = 250 V$ $I_{\max} = 22 \text{ mA}$

Service interface (CDI)

Without: *Basic specification, Position 4 (Display, Operation) = L, M, N*

Taking the following values into consideration, the device can be connected to the Endress+Hauser FXA291 service tool or a similar interface:

Service interface
$U_N = 6.5 \text{ V}$

In connection with: *Basic specification, Position 4 (Display, Operation) = L, M, N*

Taking the following values into consideration, the device can be connected to the certified Endress+Hauser FXA291 service tool or a similar interface:

Service interface																																										
$U_i = 7.3 \text{ V}$ effective inner inductance $L_i = \text{negligible}$ effective inner capacitance $C_i = \text{negligible}$																																										
$U_o = 7.3 \text{ V}$ $I_o = 100 \text{ mA}$ $P_o = 160 \text{ mW}$																																										
<table border="1"> <tr> <td>$L_o \text{ (mH)} =$</td> <td>5.00</td> <td>2.00</td> <td>1.00</td> <td>0.50</td> <td>0.20</td> <td>0.15</td> <td>0.10</td> <td>0.05</td> <td>0.02</td> <td>0.01</td> <td>0.005</td> <td>0.002</td> <td>0.001</td> </tr> <tr> <td>$C_o \text{ (}\mu\text{F)}^{1) =}$</td> <td>0.73</td> <td>1.20</td> <td>1.60</td> <td>2.00</td> <td>2.60</td> <td>-</td> <td>3.20</td> <td>4.00</td> <td>5.50</td> <td>7.30</td> <td>10.00</td> <td>12.70</td> <td>12.70</td> </tr> <tr> <td>$C_o \text{ (}\mu\text{F)}^{2) =}$</td> <td>-</td> <td>0.49</td> <td>0.90</td> <td>1.40</td> <td>-</td> <td>2.00</td> <td>-</td> <td>-</td> <td>-</td> <td>-</td> <td>-</td> <td>-</td> <td>-</td> </tr> </table>	$L_o \text{ (mH)} =$	5.00	2.00	1.00	0.50	0.20	0.15	0.10	0.05	0.02	0.01	0.005	0.002	0.001	$C_o \text{ (}\mu\text{F)}^{1) =}$	0.73	1.20	1.60	2.00	2.60	-	3.20	4.00	5.50	7.30	10.00	12.70	12.70	$C_o \text{ (}\mu\text{F)}^{2) =}$	-	0.49	0.90	1.40	-	2.00	-	-	-	-	-	-	-
$L_o \text{ (mH)} =$	5.00	2.00	1.00	0.50	0.20	0.15	0.10	0.05	0.02	0.01	0.005	0.002	0.001																													
$C_o \text{ (}\mu\text{F)}^{1) =}$	0.73	1.20	1.60	2.00	2.60	-	3.20	4.00	5.50	7.30	10.00	12.70	12.70																													
$C_o \text{ (}\mu\text{F)}^{2) =}$	-	0.49	0.90	1.40	-	2.00	-	-	-	-	-	-	-																													

- 1) Values according to PTB "ispark" program
- 2) Values according to ABNT NBR IEC 60079-25, Annex C

Micropilot FMR50/51/52/53/54/56/57

4-20 mA HART

Table of contents

Notes on the structure	18
Example diagrams of possible deratings	22
Zone 2: 1 channel	23
Zone 2: 2 channels	46

Notes on the structure

Extract from the extended order code

Device type

FMR50, FMR51, FMR52, FMR53, FMR54, FMR56, FMR57

Basic specifications

Position 1, 2 (Approval)		
Selected option		Description
FMR5x	MG ^{1) 2)}	INMETRO Ex nA IIC T6...T1 Gc
	MH ³⁾	INMETRO Ex ic IIC T6...T1 Gc

- 1) Combination with Position 4 (Display, Operation) = L, M, N in connection with Position 3 (Power Supply, Output) = A is not allowed.
- 2) The designation changes in connection with Position 4 (Display, Operation) = L, M, N and Position 3 (Power Supply, Output) = B, C, K, L: Ex nA [ia Ga] IIC T6...T1 Gc
- 3) The designation changes in connection with Position 4 (Display, Operation) = L, M, N and Position 3 (Power Supply, Output) = B, C: Ex ic [ia Ga] IIC T6...T1 Gc

Position 3 (Power Supply, Output)		
Selected option		Description
FMR5x	A	2-wire, 4-20 mA HART
	B	2-wire, 4-20 mA HART, switch output (PFS)
	C	2-wire, 4-20 mA HART, 4...20 mA
	K ¹⁾	4-wire, 90-253 VAC; 4-20 mA HART
	L ¹⁾	4-wire, 10,4-48 VDC; 4-20 mA HART

- 1) Only in connection with Position 1, 2 (Approval) = MG

Position 5 (Housing)		
Selected option		Description
FMR5x	A ¹⁾	GT19 dual compartment, plastics PBT
	C	GT20 dual compartment, Alu coated
FMR51-54 FMR57	B	GT18 dual compartment, 316L

- 1) Only in connection with Position 1, 2 (Approval) = MH

Position 7, 8 (Antenna)		
Selected option		Description
FMR50	BM	Horn 40 mm/1½", PVDF encapsulated, -40...130°C
	BN	Horn 80 mm/3", PP cladded, -40...80°C
	BR	Horn 100 mm/4", PP cladded, -40...80°C
FMR51	Bx	Horn (different sizes)
FMR52	BO	Horn 50 mm/2", -40...200°C ¹⁾ , -196...200°C ²⁾ , flush mount
	BP	Horn 80 mm/3", -40...200°C ¹⁾ , -196...200°C ²⁾ , flush mount
FMR53	Cx	Rod (different sizes)

Position 7, 8 (Antenna)		
Selected option		Description
FMR54	Ax	Without Horn
	Bx	Horn (different sizes)
	Dx	Planar (different sizes)
FMR56	BN	Horn 80 mm/3", PP cladded, -40...80°C
	BR	Horn 100 mm/4", PP cladded, -40...80°C
FMR57	Bx	Horn (different sizes)
	Fx	Parabolic (different sizes)

 Shown in the temperature tables exemplary as follows:

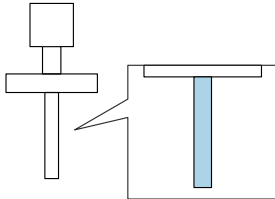

- 1) In connection with Position 5 (Housing) = A
- 2) Only in connection with Position 5 (Housing) = B, C

Position 9, 10 (Seal)		
Selected option		Description
FMR51	A5	Viton GLT, -40...150°C
	C1	Kalrez, -20...150°C
	D2	Graphite, -196...450°C (HT)
	D3	Graphite, -40...250°C (XT)
FMR54	A7	Viton, -20...150°C (Planar)
	A8	Viton, -40...200°C
	B4	EPDM, -40...150°C
	C2	Kalrez, -20...200°C, conductive media max. 150°C
	D1	Graphite, -196...280°C (XT)
	D2	Graphite, -196...400°C (HT)
FMR57	A6	Viton GLT, -40...200°C
	D4	Graphite, -40...400°C (HT)

 Shown in the temperature tables exemplary as follows:

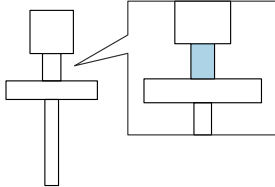

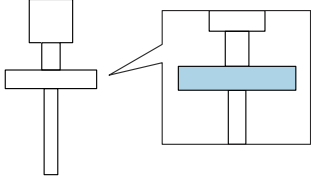



Position 11-13 (Process Connection)		
Selected option		Description
FMR51-54 FMR57	Axx Cxx Kxx	Flange (different sizes)
FMR50	GGF RGF	Thread, PVDF
	UAE	Mounting bracket
	XRO	Connection, without flange/mounting bracket
	XxG	Slip on flange (different sizes)
FMR51	Pxx	Flange (different sizes)
	Rxx	Thread
	Txx	Tri-Clamp
FMR52	Mxx	Slotted-nut
	Txx	Tri-Clamp
FMR53	Rxj	Thread, 316L
	RxF	Thread, PVDF
FMR56	UAE	Mounting bracket
	XRO	Connection, without flange/mounting bracket
	XxG	Slip on flange (different sizes)
FMR57	Rxj	Thread, 316L
	Xxj	Align. device (different sizes)
 Shown in the temperature tables exemplary as follows:		

Optional specifications

ID Jx (Test, Certificate)		
Selected option		Description
FMR51 ¹⁾ FMR52 FMR54 ²⁾	JN ³⁾	Ambient temperature transmitter -50°C

- 1) Only in connection with Position 9, 10 (Seal) = D2
- 2) Only in connection with Position 9, 10 (Seal) = D1, D2
- 3) Only in connection with Position 1, 2 (Approval) = MH and Position 5 (Housing) = B, C

General notes

-  *Optional specification, ID Nx, Ox (Accessory Mounted) = NA (Overvoltage protection Type OVP10 and Type OVP20)*
When using the internal overvoltage protection: Reduce the admissible ambient temperature at the housing by 2 K.
Basic specification, Position 5 (Housing) = A
When using the remote display FHX50: Reduce the admissible ambient temperature at the housing by 3 K.
-  Observe the permitted temperature range at the antenna.
-  *Basic specification, Position 1, 2 (Approval) = MG in connection with Basic specification, Position 3 (Power Supply, Output) = B*
Deratings are based on a power consumption of 1 W (PFS); →  13.

Description notes

-  Unless otherwise indicated, the positions always refer to the basic specification.

1st column: Position 5 (Housing) = A, B, ...

2nd column: Position 3 (Power Supply, Output) = A, B, ..

- (1): 1 channel used
- (2): 2 channels used

3rd column: Temperature classes T6 (85 °C) to T1 (450 °C)

Column P1 to P6: Position (temperature value) on the axes of the derating

- T_a: Ambient temperature in °C
- T_p: Process temperature in °C

-  Column P6 is only relevant for version B of the derating.

→  22

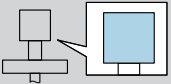
 = C	(1)	P1		P2		P3		P4		P5		P6		
		T _p	T _a	T _p	T _a	T _p	T _a	T _p	T _a	T _p	T _a	T _p	T _a	
	A, B, C	T6	-40	60	60	60	85	53	85	-40	-40	-40	-	-
		T5	-40	75	75	75	100	68	100	-40	-40	-40	-	-
		T4	-40	80	80	80	135	67	135	-40	-40	-40	-	-
		T3	-40	80	80	80	200	51	200	-40	-40	-40	-	-

A0038021-EN

Example diagrams
of possible deratings

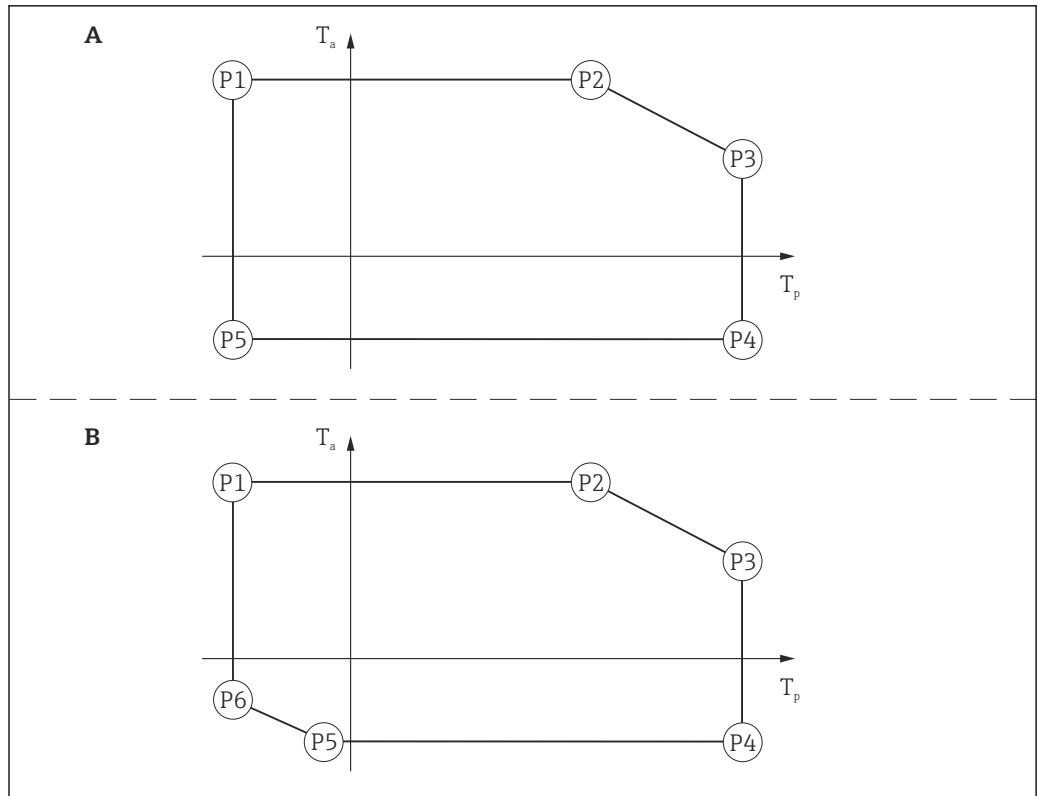

A0022717

3

Zone 2: 1 channel

Position 3 (Power Supply, Output) = A, B, C, K, L: 1 channel used

Page references to the temperature tables of the respective device types: See the following list.

- FMR50 → 23
- FMR51 → 24
- FMR52 → 29
- FMR53 → 33
- FMR54 → 35
- FMR56 → 42
- FMR57 → 43

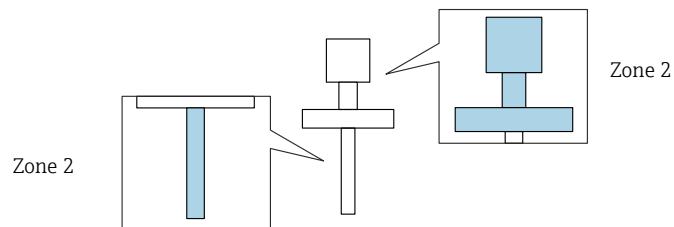

FMR50

	(1)		P1		P2		P3		P4		P5		P6	
			T _p	T _a	T _p	T _a	T _p	T _a	T _p	T _a	T _p	T _a	T _p	T _a
	A, C	T6	-40	60	60	60	80	55	80	-40	-40	-40	-	-
	B	T6	-40	57	57	57	80	54	80	-40	-40	-40	-	-

	(1)		P1		P2		P3		P4		P5		P6	
			T _p	T _a	T _p	T _a	T _p	T _a	T _p	T _a	T _p	T _a	T _p	T _a
	A, B, C	T6	-40	60	60	60	80	58	80	-40	-40	-40	-	-
	K, L	T6	-40	60	60	60	80	58	80	-40	-40	-40	-	-

FMR51

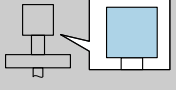
 = A	(1)	P1		P2		P3		P4		P5		P6		
		T _p	T _a	T _p	T _a	T _p	T _a	T _p	T _a	T _p	T _a	T _p	T _a	
	A, C	T6	-40	60	60	60	85	49	85	-40	-40	-40	-	-
		T5	-40	75	75	75	100	64	100	-40	-40	-40	-	-
		T4	-40	79	79	79	135	63	135	-40	-40	-40	-	-
		T3 ¹⁾	-40	79	79	79	150	56	150	-40	-40	-40	-	-
	B	T6	-40	60	60	60	85	49	85	-40	-40	-40	-	-
		T5	-40	72	72	72	100	64	100	-40	-40	-40	-	-
		T4	-40	72	72	72	135	57	135	-40	-40	-40	-	-
		T3 ¹⁾	-40	72	72	72	150	53	150	-40	-40	-40	-	-

1) Functional: Maximum permissible process temperature

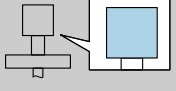
 = B	(1)	P1		P2		P3		P4		P5		P6		
		T _p	T _a	T _p	T _a	T _p	T _a	T _p	T _a	T _p	T _a	T _p	T _a	
	A, B, C	T6	-40	60	60	60	85	54	85	-40	-40	-40	-	-
		T5	-40	75	75	75	100	69	100	-40	-40	-40	-	-
		T4	-40	80	80	80	135	68	135	-40	-40	-40	-	-
		T3 ¹⁾	-40	80	80	80	150	65	150	-40	-40	-40	-	-
	K, L	T6	-40	60	60	60	85	54	85	-40	-40	-40	-	-
		T5	-40	75	75	75	100	69	100	-40	-40	-40	-	-
		T4	-40	76	76	76	135	64	135	-40	-40	-40	-	-
		T3 ¹⁾	-40	76	76	76	150	61	150	-40	-40	-40	-	-

1) Functional: Maximum permissible process temperature

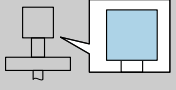
 = C	(1)	P1		P2		P3		P4		P5		P6		
		T _p	T _a	T _p	T _a	T _p	T _a	T _p	T _a	T _p	T _a	T _p	T _a	
	A, B, C	T6	-40	60	60	60	85	55	85	-40	-40	-40	-	-
		T5	-40	75	75	75	100	70	100	-40	-40	-40	-	-
		T4	-40	80	80	80	135	70	135	-40	-40	-40	-	-
		T3 ¹⁾	-40	80	80	80	150	68	150	-40	-40	-40	-	-
	K, L	T6	-40	60	60	60	85	55	85	-40	-40	-40	-	-
		T5	-40	75	75	75	100	70	100	-40	-40	-40	-	-
		T4	-40	76	76	76	135	66	135	-40	-40	-40	-	-
		T3 ¹⁾	-40	76	76	76	150	64	150	-40	-40	-40	-	-

1) Functional: Maximum permissible process temperature

FMR51

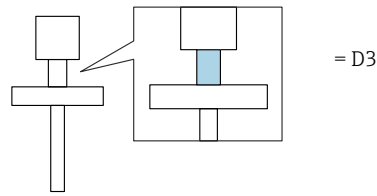

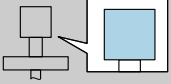
 = A	(1)	P1		P2		P3		P4		P5		P6		
		T _p	T _a	T _p	T _a	T _p	T _a	T _p	T _a	T _p	T _a	T _p	T _a	
	A, C	T6	-40	60	60	60	85	54	85	-40	-40	-40	-	-
		T5	-40	75	75	75	100	69	100	-40	-40	-40	-	-
		T4	-40	79	79	79	135	71	135	-40	-40	-40	-	-
		T3	-40	79	79	79	200	56	200	-40	-40	-40	-	-
		T2 ¹⁾	-40	79	79	79	250	44	250	-40	-40	-40	-	-
	B	T6	-40	57	57	57	85	53	85	-40	-40	-40	-	-
		T5	-40	72	72	72	100	68	100	-40	-40	-40	-	-
		T4	-40	72	72	72	135	63	135	-40	-40	-40	-	-
		T3	-40	72	72	72	200	53	200	-40	-40	-40	-	-
		T2 ¹⁾	-40	72	72	72	250	44	250	-40	-40	-40	-	-

1) Functional: Maximum permissible process temperature

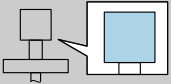
 = B	(1)	P1		P2		P3		P4		P5		P6		
		T _p	T _a	T _p	T _a	T _p	T _a	T _p	T _a	T _p	T _a	T _p	T _a	
	A, B, C	T6	-40	60	60	60	85	57	85	-40	-40	-40	-	-
		T5	-40	75	75	75	100	72	100	-40	-40	-40	-	-
		T4	-40	80	80	80	135	74	135	-40	-40	-40	-	-
		T3	-40	80	80	80	200	67	200	-40	-40	-40	-	-
		T2 ¹⁾	-40	80	80	80	250	62	250	-40	-40	-40	-	-
	K, L	T6	-40	60	60	60	85	57	85	-40	-40	-40	-	-
		T5	-40	75	75	75	100	72	100	-40	-40	-40	-	-
		T4	-40	76	76	76	135	70	135	-40	-40	-40	-	-
		T3	-40	76	76	76	200	63	200	-40	-40	-40	-	-
		T2 ¹⁾	-40	76	76	76	250	58	250	-40	-40	-40	-	-

1) Functional: Maximum permissible process temperature

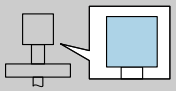
 = C	(1)	P1		P2		P3		P4		P5		P6		
		T _p	T _a	T _p	T _a	T _p	T _a	T _p	T _a	T _p	T _a	T _p	T _a	
	A, B, C	T6	-40	60	60	60	85	58	85	-40	-40	-40	-	-
		T5	-40	75	75	75	100	73	100	-40	-40	-40	-	-
		T4	-40	80	80	80	135	75	135	-40	-40	-40	-	-
		T3	-40	80	80	80	200	70	200	-40	-40	-40	-	-
		T2 ¹⁾	-40	80	80	80	250	66	250	-40	-40	-40	-	-
	K, L	T6	-40	60	60	60	85	58	85	-40	-40	-40	-	-
		T5	-40	75	75	75	100	73	100	-40	-40	-40	-	-
		T4	-40	76	76	76	135	72	135	-40	-40	-40	-	-
		T3	-40	76	76	76	200	66	200	-40	-40	-40	-	-
		T2 ¹⁾	-40	76	76	76	250	62	250	-40	-40	-40	-	-

1) Functional: Maximum permissible process temperature

FMR51

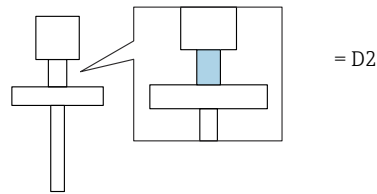

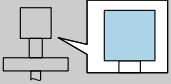
 = A	(1)	P1		P2		P3		P4		P5		P6		
		T _p	T _a	T _p	T _a	T _p	T _a	T _p	T _a	T _p	T _a	T _p	T _a	
	A, C	T6	-196	60	60	60	85	52	85	-40	-40	-40	-196	9
		T5	-196	75	75	75	100	67	100	-40	-40	-40	-196	9
		T4	-196	79	79	79	135	69	135	-40	-40	-40	-196	9
		T3	-196	79	79	79	200	49	200	-40	-40	-40	-196	9
	B	T6	-196	60	60	60	85	52	85	-40	-40	-40	-196	9
		T5	-196	72	72	72	100	67	100	-40	-40	-40	-196	9
		T4	-196	72	72	72	135	61	135	-40	-40	-40	-196	9
		T3	-196	72	72	72	200	49	200	-40	-40	-40	-196	9

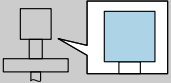
 = B	(1)	P1		P2		P3		P4		P5		P6		
		T _p	T _a	T _p	T _a	T _p	T _a	T _p	T _a	T _p	T _a	T _p	T _a	
	A, B, C	T6	-196	60	60	60	85	56	85	-40 -50 ¹⁾	-40 -50 ¹⁾	-40 -50 ¹⁾	-196	-15
		T5	-196	75	75	75	100	71	100	-40 -50 ¹⁾	-40 -50 ¹⁾	-40 -50 ¹⁾	-196	-15
		T4	-196	80	80	80	135	72	135	-40 -50 ¹⁾	-40 -50 ¹⁾	-40 -50 ¹⁾	-196	-15
		T3	-196	80	80	80	200	64	200	-40 -50 ¹⁾	-40 -50 ¹⁾	-40 -50 ¹⁾	-196	-15
		T2	-196	80	80	80	300	50	300	-40 -50 ¹⁾	-40 -50 ¹⁾	-40 -50 ¹⁾	-196	-15
	K, L	T6	-196	60	60	60	85	56	85	-40	-40	-40	-196	-15
		T5	-196	75	75	75	100	71	100	-40	-40	-40	-196	-15
		T4	-196	76	76	76	135	68	135	-40	-40	-40	-196	-15
		T3	-196	76	76	76	200	60	200	-40	-40	-40	-196	-15
		T2	-196	76	76	76	300	46	300	-40	-40	-40	-196	-15

1) Only in connection with Optional specification, ID Jx (Test, Certificate) = JN

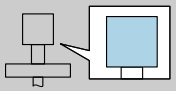
 = C	(1)	P1		P2		P3		P4		P5		P6		
		T _p	T _a	T _p	T _a	T _p	T _a	T _p	T _a	T _p	T _a	T _p	T _a	
	A, B, C	T6	-196	60	60	60	85	57	85	-40 -50 ¹⁾	-40 -50 ¹⁾	-40 -50 ¹⁾	-196	-20 -28 ¹⁾
		T5	-196	75	75	75	100	72	100	-40 -50 ¹⁾	-40 -50 ¹⁾	-40 -50 ¹⁾	-196	-20 -28 ¹⁾
		T4	-196	80	80	80	135	74	135	-40 -50 ¹⁾	-40 -50 ¹⁾	-40 -50 ¹⁾	-196	-20 -28 ¹⁾
		T3	-196	80	80	80	200	67	200	-40 -50 ¹⁾	-40 -50 ¹⁾	-40 -50 ¹⁾	-196	-20 -28 ¹⁾
		T2	-196	80	80	80	300	56	300	-40 -50 ¹⁾	-40 -50 ¹⁾	-40 -50 ¹⁾	-196	-20 -28 ¹⁾
		T1	-196	80	80	80	450	39	450	-40 -50 ¹⁾	-40 -50 ¹⁾	-40 -50 ¹⁾	-196	-20 -28 ¹⁾
	K, L	T6	-196	60	60	60	85	57	85	-40	-40	-40	-196	-20
		T5	-196	75	75	75	100	72	100	-40	-40	-40	-196	-20
		T4	-196	76	76	76	135	70	135	-40	-40	-40	-196	-20
		T3	-196	76	76	76	200	63	200	-40	-40	-40	-196	-20
		T2	-196	76	76	76	300	52	300	-40	-40	-40	-196	-20
		T1	-196	76	76	76	450	36	450	-40	-40	-40	-196	-20

1) Only in connection with Optional specification, ID Jx (Test, Certificate) = JN

FMR52

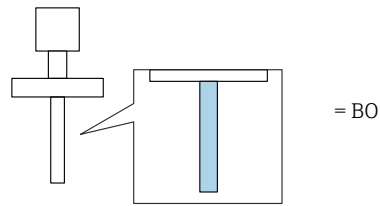

	(1)	P1		P2		P3		P4		P5		P6		
		T _p	T _a	T _p	T _a	T _p	T _a	T _p	T _a	T _p	T _a	T _p	T _a	
	A, C	T6	-40	60	60	60	85	51	85	-40	-40	-40	-	-
		T5	-40	75	75	75	100	66	100	-40	-40	-40	-	-
		T4	-40	79	79	79	135	66	135	-40	-40	-40	-	-
		T3	-40	79	79	79	200	42	200	-40	-40	-40	-	-
	B	T6	-40	60	60	60	85	51	85	-40	-40	-40	-	-
		T5	-40	72	72	72	100	66	100	-40	-40	-40	-	-
		T4	-40	72	72	72	135	59	135	-40	-40	-40	-	-
		T3	-40	72	72	72	200	42	200	-40	-40	-40	-	-

	(1)	P1		P2		P3		P4		P5		P6		
		T _p	T _a	T _p	T _a	T _p	T _a	T _p	T _a	T _p	T _a	T _p	T _a	
	A, B, C	T6	-196	60	60	60	85	55	85	-40 -50 ¹⁾	-40 -50 ¹⁾	-40 -50 ¹⁾	-196	-3
		T5	-196	75	75	75	100	70	100	-40 -50 ¹⁾	-40 -50 ¹⁾	-40 -50 ¹⁾	-196	-3
		T4	-196	80	80	80	135	71	135	-40 -50 ¹⁾	-40 -50 ¹⁾	-40 -50 ¹⁾	-196	-3
		T3	-196	80	80	80	200	59	200	-40 -50 ¹⁾	-40 -50 ¹⁾	-40 -50 ¹⁾	-196	-3
	K, L	T6	-196	60	60	60	85	55	85	-40	-40	-40	-196	-3
		T5	-196	75	75	75	100	70	100	-40	-40	-40	-196	-3
		T4	-196	76	76	76	135	66	135	-40	-40	-40	-196	-3
		T3	-196	76	76	76	200	55	200	-40	-40	-40	-196	-3

1) Only in connection with Optional specification, ID Jx (Test, Certificate) = JN

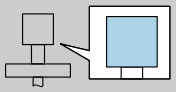
 = C	(1)	P1		P2		P3		P4		P5		P6		
		T _p	T _a	T _p	T _a	T _p	T _a	T _p	T _a	T _p	T _a	T _p	T _a	
	A, B, C	T6	-196	60	60	60	85	56	85	-40 -50 ¹⁾	-40 -50 ¹⁾	-40 -50 ¹⁾	-196	-14
		T5	-196	75	75	75	100	71	100	-40 -50 ¹⁾	-40 -50 ¹⁾	-40 -50 ¹⁾	-196	-14
		T4	-196	80	80	80	135	72	135	-40 -50 ¹⁾	-40 -50 ¹⁾	-40 -50 ¹⁾	-196	-14
		T3	-196	80	80	80	200	63	200	-40 -50 ¹⁾	-40 -50 ¹⁾	-40 -50 ¹⁾	-196	-14
	K, L	T6	-196	60	60	60	85	56	85	-40	-40	-40	-196	-14
		T5	-196	75	75	75	100	71	100	-40	-40	-40	-196	-14
		T4	-196	76	76	76	135	68	135	-40	-40	-40	-196	-14
		T3	-196	76	76	76	200	59	200	-40	-40	-40	-196	-14

1) Only in connection with Optional specification, ID Jx (Test, Certificate) = JN

FMR52

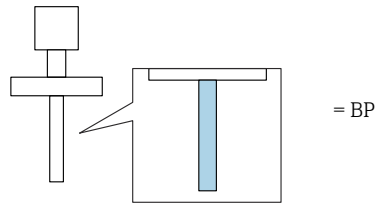

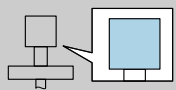
 = A	(1)	P1		P2		P3		P4		P5		P6		
		T _p	T _a	T _p	T _a	T _p	T _a	T _p	T _a	T _p	T _a	T _p	T _a	
	A, C	T6	-40	60	60	60	85	49	85	-40	-40	-40	-	-
		T5	-40	75	75	75	100	64	100	-40	-40	-40	-	-
		T4	-40	79	79	79	135	64	135	-40	-40	-40	-	-
		T3	-40	79	79	79	200	36	200	-40	-40	-40	-	-
	B	T6	-40	60	60	60	85	49	85	-40	-40	-40	-	-
		T5	-40	72	72	72	100	64	100	-40	-40	-40	-	-
		T4	-40	72	72	72	135	57	135	-40	-40	-40	-	-
		T3	-40	72	72	72	200	36	200	-40	-40	-40	-	-

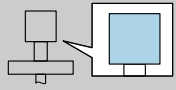
 = B	(1)	P1		P2		P3		P4		P5		P6		
		T _p	T _a	T _p	T _a	T _p	T _a	T _p	T _a	T _p	T _a	T _p	T _a	
	A, B, C	T6	-196	60	60	60	85	54	85	-40 -50 ¹⁾	-40 -50 ¹⁾	-40 -50 ¹⁾	-196	10
		T5	-196	75	75	75	100	69	100	-40 -50 ¹⁾	-40 -50 ¹⁾	-40 -50 ¹⁾	-196	10
		T4	-196	80	80	80	135	69	135	-40 -50 ¹⁾	-40 -50 ¹⁾	-40 -50 ¹⁾	-196	10
		T3	-196	80	80	80	200	55	200	-40 -50 ¹⁾	-40 -50 ¹⁾	-40 -50 ¹⁾	-196	10
	K, L	T6	-196	60	60	60	85	54	85	-40	-40	-40	-196	10
		T5	-196	75	75	75	100	69	100	-40	-40	-40	-196	10
		T4	-196	76	76	76	135	64	135	-40	-40	-40	-196	10
		T3	-196	76	76	76	200	51	200	-40	-40	-40	-196	10

1) Only in connection with Optional specification, ID Jx (Test, Certificate) = JN

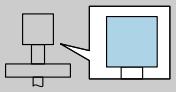
 = C	(1)	P1		P2		P3		P4		P5		P6		
		T _p	T _a	T _p	T _a	T _p	T _a	T _p	T _a	T _p	T _a	T _p	T _a	
	A, B, C	T6	-196	60	60	60	85	55	85	-40 -50 ¹⁾	-40 -50 ¹⁾	-40 -50 ¹⁾	-196	-8
		T5	-196	75	75	75	100	70	100	-40 -50 ¹⁾	-40 -50 ¹⁾	-40 -50 ¹⁾	-196	-8
		T4	-196	80	80	80	135	71	135	-40 -50 ¹⁾	-40 -50 ¹⁾	-40 -50 ¹⁾	-196	-8
		T3	-196	80	80	80	200	60	200	-40 -50 ¹⁾	-40 -50 ¹⁾	-40 -50 ¹⁾	-196	-8
	K, L	T6	-196	60	60	60	85	55	85	-40	-40	-40	-196	-8
		T5	-196	75	75	75	100	70	100	-40	-40	-40	-196	-8
		T4	-196	76	76	76	135	67	135	-40	-40	-40	-196	-8
		T3	-196	76	76	76	200	56	200	-40	-40	-40	-196	-8

1) Only in connection with Optional specification, ID Jx (Test, Certificate) = JN

FMR53

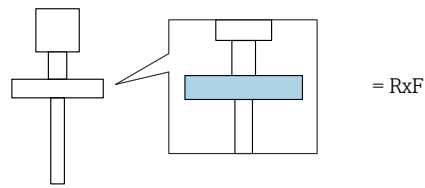

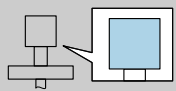
 = A	(1)		P1		P2		P3		P4		P5		P6	
			T _p	T _a	T _p	T _a	T _p	T _a	T _p	T _a	T _p	T _a	T _p	T _a
	A, C	T6	-40	60	60	60	80	56	80	-40	-40	-40	-	-
	B	T6	-40	57	57	57	80	55	80	-40	-40	-40	-	-

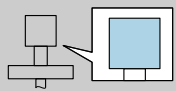
 = B, C	(1)		P1		P2		P3		P4		P5		P6	
			T _p	T _a	T _p	T _a	T _p	T _a	T _p	T _a	T _p	T _a	T _p	T _a
	A, B, C	T6	-40	60	60	60	80	58	80	-40	-40	-40	-	-
	K, L	T6	-40	60	60	60	80	58	80	-40	-40	-40	-	-

FMR53

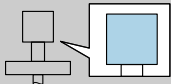
 = A	(1)	P1		P2		P3		P4		P5		P6		
		T _p	T _a	T _p	T _a	T _p	T _a	T _p	T _a	T _p	T _a	T _p	T _a	
	A, C	T6	-40	60	60	60	85	48	85	-40	-40	-40	-	-
		T5	-40	75	75	75	100	63	100	-40	-40	-40	-	-
		T4	-40	79	79	79	135	62	135	-40	-40	-40	-	-
		T3 ¹⁾	-40	79	79	79	150	55	150	-40	-40	-40	-	-
	B	T6	-40	60	60	60	85	48	85	-40	-40	-40	-	-
		T5	-40	72	72	72	100	63	100	-40	-40	-40	-	-
		T4	-40	72	72	72	135	56	135	-40	-40	-40	-	-
		T3 ¹⁾	-40	72	72	72	150	52	150	-40	-40	-40	-	-

1) Functional: Maximum permissible process temperature

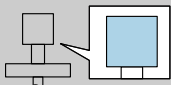
 = B	(1)	P1		P2		P3		P4		P5		P6		
		T _p	T _a	T _p	T _a	T _p	T _a	T _p	T _a	T _p	T _a	T _p	T _a	
	A, B, C	T6	-40	60	60	60	85	53	85	-40	-40	-40	-	-
		T5	-40	75	75	75	100	68	100	-40	-40	-40	-	-
		T4	-40	80	80	80	135	67	135	-40	-40	-40	-	-
		T3 ¹⁾	-40	80	80	80	150	64	150	-40	-40	-40	-	-
	K, L	T6	-40	60	60	60	85	53	85	-40	-40	-40	-	-
		T5	-40	75	75	75	100	68	100	-40	-40	-40	-	-
		T4	-40	76	76	76	135	63	135	-40	-40	-40	-	-
		T3 ¹⁾	-40	76	76	76	150	59	150	-40	-40	-40	-	-

1) Functional: Maximum permissible process temperature

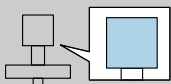
 = C	(1)	P1		P2		P3		P4		P5		P6		
		T _p	T _a	T _p	T _a	T _p	T _a	T _p	T _a	T _p	T _a	T _p	T _a	
	A, B, C	T6	-40	60	60	60	85	54	85	-40	-40	-40	-	-
		T5	-40	75	75	75	100	69	100	-40	-40	-40	-	-
		T4	-40	80	80	80	135	70	135	-40	-40	-40	-	-
		T3 ¹⁾	-40	80	80	80	150	67	150	-40	-40	-40	-	-
	K, L	T6	-40	60	60	60	85	54	85	-40	-40	-40	-	-
		T5	-40	75	75	75	100	69	100	-40	-40	-40	-	-
		T4	-40	76	76	76	135	65	135	-40	-40	-40	-	-
		T3 ¹⁾	-40	76	76	76	150	63	150	-40	-40	-40	-	-

1) Functional: Maximum permissible process temperature

FMR54

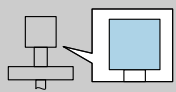
 = A	(1)	P1		P2		P3		P4		P5		P6		
		T _p	T _a	T _p	T _a	T _p	T _a	T _p	T _a	T _p	T _a	T _p	T _a	
	A, C	T6	-40	60	60	60	85	48	85	-40	-40	-40	-	-
		T5	-40	75	75	75	100	63	100	-40	-40	-40	-	-
		T4	-40	79	79	79	135	61	135	-40	-40	-40	-	-
	B	T6	-40	60	60	60	85	48	85	-40	-40	-40	-	-
		T5	-40	72	72	72	100	63	100	-40	-40	-40	-	-
		T4	-40	72	72	72	135	55	135	-40	-40	-40	-	-

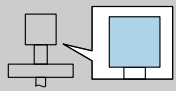
 = B	(1)	P1		P2		P3		P4		P5		P6		
		T _p	T _a	T _p	T _a	T _p	T _a	T _p	T _a	T _p	T _a	T _p	T _a	
	A, B, C	T6	-40	60	60	60	85	53	85	-40	-40	-40	-	-
		T5	-40	75	75	75	100	68	100	-40	-40	-40	-	-
		T4	-40	80	80	80	135	67	135	-40	-40	-40	-	-
		T3	-40	80	80	80	200	51	200	-40	-40	-40	-	-
	K, L	T6	-40	60	60	60	85	53	85	-40	-40	-40	-	-
		T5	-40	75	75	75	100	68	100	-40	-40	-40	-	-
		T4	-40	76	76	76	135	62	135	-40	-40	-40	-	-
		T3	-40	76	76	76	200	46	200	-40	-40	-40	-	-

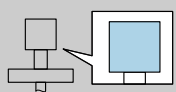
 = C	(1)	P1		P2		P3		P4		P5		P6		
		T _p	T _a	T _p	T _a	T _p	T _a	T _p	T _a	T _p	T _a	T _p	T _a	
	A, B, C	T6	-40	60	60	60	85	54	85	-40	-40	-40	-	-
		T5	-40	75	75	75	100	69	100	-40	-40	-40	-	-
		T4	-40	80	80	80	135	69	135	-40	-40	-40	-	-
		T3	-40	80	80	80	200	56	200	-40	-40	-40	-	-
	K, L	T6	-40	60	60	60	85	54	85	-40	-40	-40	-	-
		T5	-40	75	75	75	100	69	100	-40	-40	-40	-	-
		T4	-40	76	76	76	135	65	135	-40	-40	-40	-	-
		T3	-40	76	76	76	200	52	200	-40	-40	-40	-	-

FMR54

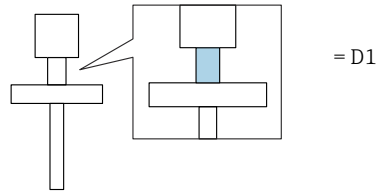

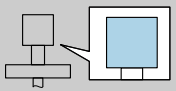
 = A	(1)	P1		P2		P3		P4		P5		P6		
		T _p	T _a	T _p	T _a	T _p	T _a	T _p	T _a	T _p	T _a	T _p	T _a	
	A, C	T6	-196	60	60	60	85	51	85	-40	-40	-40	-196	18
		T5	-196	75	75	75	100	66	100	-40	-40	-40	-196	18
		T4	-196	79	79	79	135	66	135	-40	-40	-40	-196	18
		T3	-196	79	79	79	200	42	200	-40	-40	-40	-196	18
	B	T6	-196	60	60	60	85	51	85	-40	-40	-40	-196	18
		T5	-196	72	72	72	100	66	100	-40	-40	-40	-196	18
		T4	-196	72	72	72	135	59	135	-40	-40	-40	-196	18
		T3	-196	72	72	72	200	42	200	-40	-40	-40	-196	18

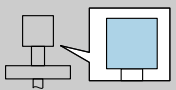
 = B	(1)	P1		P2		P3		P4		P5		P6		
		T _p	T _a	T _p	T _a	T _p	T _a	T _p	T _a	T _p	T _a	T _p	T _a	
	A, B, C	T6	-196	60	60	60	85	55	85	-40 -50 ¹⁾	-40 -50 ¹⁾	-40 -50 ¹⁾	-196	-4
		T5	-196	75	75	75	100	70	100	-40 -50 ¹⁾	-40 -50 ¹⁾	-40 -50 ¹⁾	-196	-4
		T4	-196	80	80	80	135	71	135	-40 -50 ¹⁾	-40 -50 ¹⁾	-40 -50 ¹⁾	-196	-4
		T3	-196	80	80	80	200	60	200	-40 -50 ¹⁾	-40 -50 ¹⁾	-40 -50 ¹⁾	-196	-4
		T2 ²⁾	-196	80	80	80	280	46	280	-40 -50 ¹⁾	-40 -50 ¹⁾	-40 -50 ¹⁾	-196	-4
	K, L	T6	-196	60	60	60	85	55	85	-40	-40	-40	-196	-4
		T5	-196	75	75	75	100	70	100	-40	-40	-40	-196	-4
		T4	-196	76	76	76	135	67	135	-40	-40	-40	-196	-4
		T3	-196	76	76	76	200	55	200	-40	-40	-40	-196	-4
		T2 ²⁾	-196	76	76	76	280	42	280	-40	-40	-40	-196	-4

1) Only in connection with Optional specification, ID Jx (Test, Certificate) = JN

2) Functional: Maximum permissible process temperature

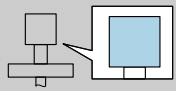
 = C	(1)	P1		P2		P3		P4		P5		P6		
		T _p	T _a	T _p	T _a	T _p	T _a	T _p	T _a	T _p	T _a	T _p	T _a	
	A, B, C	T6	-196	60	60	60	85	56	85	-40 -50 ¹⁾	-40 -50 ¹⁾	-40 -50 ¹⁾	-196	-15
		T5	-196	75	75	75	100	71	100	-40 -50 ¹⁾	-40 -50 ¹⁾	-40 -50 ¹⁾	-196	-15
		T4	-196	80	80	80	135	72	135	-40 -50 ¹⁾	-40 -50 ¹⁾	-40 -50 ¹⁾	-196	-15
		T3	-196	80	80	80	200	64	200	-40 -50 ¹⁾	-40 -50 ¹⁾	-40 -50 ¹⁾	-196	-15
		T2 ²⁾	-196	80	80	80	280	53	280	-40 -50 ¹⁾	-40 -50 ¹⁾	-40 -50 ¹⁾	-196	-15
	K, L	T6	-196	60	60	60	85	56	85	-40	-40	-40	-196	-15
		T5	-196	75	75	75	100	71	100	-40	-40	-40	-196	-15
		T4	-196	76	76	76	135	69	135	-40	-40	-40	-196	-15
		T3	-196	76	76	76	200	60	200	-40	-40	-40	-196	-15
		T2 ²⁾	-196	76	76	76	280	49	280	-40	-40	-40	-196	-15

- 1) Only in connection with Optional specification, ID Jx (Test, Certificate) = JN
 2) Functional: Maximum permissible process temperature

FMR54

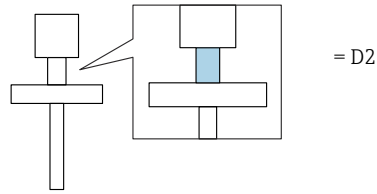

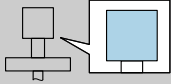
 = A	(1)	P1		P2		P3		P4		P5		P6		
		T _p	T _a	T _p	T _a	T _p	T _a	T _p	T _a	T _p	T _a	T _p	T _a	
	A, C	T6	-196	60	60	60	85	52	85	-40	-40	-40	-196	11
		T5	-196	75	75	75	100	67	100	-40	-40	-40	-196	11
		T4	-196	79	79	79	135	69	135	-40	-40	-40	-196	11
		T3	-196	79	79	79	200	47	200	-40	-40	-40	-196	11
	B	T6	-196	60	60	60	85	52	85	-40	-40	-40	-196	11
		T5	-196	72	72	72	100	67	100	-40	-40	-40	-196	11
		T4	-196	72	72	72	135	60	135	-40	-40	-40	-196	11
		T3	-196	72	72	72	200	47	200	-40	-40	-40	-196	11

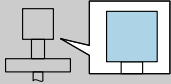
 = B	(1)	P1		P2		P3		P4		P5		P6		
		T _p	T _a	T _p	T _a	T _p	T _a	T _p	T _a	T _p	T _a	T _p	T _a	
	A, B, C	T6	-196	60	60	60	85	56	85	-40 -50 ¹⁾	-40 -50 ¹⁾	-40 -50 ¹⁾	-196	-13
		T5	-196	75	75	75	100	71	100	-40 -50 ¹⁾	-40 -50 ¹⁾	-40 -50 ¹⁾	-196	-13
		T4	-196	80	80	80	135	72	135	-40 -50 ¹⁾	-40 -50 ¹⁾	-40 -50 ¹⁾	-196	-13
		T3	-196	80	80	80	200	62	200	-40 -50 ¹⁾	-40 -50 ¹⁾	-40 -50 ¹⁾	-196	-13
		T2	-196	80	80	80	300	48	300	-40 -50 ¹⁾	-40 -50 ¹⁾	-40 -50 ¹⁾	-196	-13
		T1 ²⁾	-196	80	80	80	400	31	400	-40 -50 ¹⁾	-40 -50 ¹⁾	-40 -50 ¹⁾	-196	-13
	K, L	T6	-196	60	60	60	85	56	85	-40	-40	-40	-196	-13
		T5	-196	75	75	75	100	71	100	-40	-40	-40	-196	-13
		T4	-196	76	76	76	135	68	135	-40	-40	-40	-196	-13
		T3	-196	76	76	76	200	58	200	-40	-40	-40	-196	-13
		T2	-196	76	76	76	300	44	300	-40	-40	-40	-196	-13

1) Only in connection with Optional specification, ID Jx (Test, Certificate) = JN

2) Functional: Maximum permissible process temperature

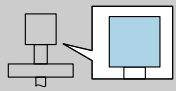
 = C	(1)	P1		P2		P3		P4		P5		P6		
		T _p	T _a	T _p	T _a	T _p	T _a	T _p	T _a	T _p	T _a	T _p	T _a	
	A, B, C	T6	-196	60	60	60	85	57	85	-40 -50 ¹⁾	-40 -50 ¹⁾	-40 -50 ¹⁾	-196	-19 -26 ¹⁾
		T5	-196	75	75	75	100	72	100	-40 -50 ¹⁾	-40 -50 ¹⁾	-40 -50 ¹⁾	-196	-19 -26 ¹⁾
		T4	-196	80	80	80	135	74	135	-40 -50 ¹⁾	-40 -50 ¹⁾	-40 -50 ¹⁾	-196	-19 -26 ¹⁾
		T3	-196	80	80	80	200	66	200	-40 -50 ¹⁾	-40 -50 ¹⁾	-40 -50 ¹⁾	-196	-19 -26 ¹⁾
		T2	-196	80	80	80	300	54	300	-40 -50 ¹⁾	-40 -50 ¹⁾	-40 -50 ¹⁾	-196	-19 -26 ¹⁾
		T1 ²⁾	-196	80	80	80	400	42	400	-40 -50 ¹⁾	-40 -50 ¹⁾	-40 -50 ¹⁾	-196	-19 -26 ¹⁾
	K, L	T6	-196	60	60	60	85	57	85	-40	-40	-40	-196	-19
		T5	-196	75	75	75	100	72	100	-40	-40	-40	-196	-19
		T4	-196	76	76	76	135	70	135	-40	-40	-40	-196	-19
		T3	-196	76	76	76	200	62	200	-40	-40	-40	-196	-19
		T2	-196	76	76	76	300	50	300	-40	-40	-40	-196	-19
		T1 ²⁾	-196	76	76	76	400	39	400	-40	-40	-40	-196	-19

- 1) Only in connection with Optional specification, ID Jx (Test, Certificate) = JN
- 2) Functional: Maximum permissible process temperature

FMR54

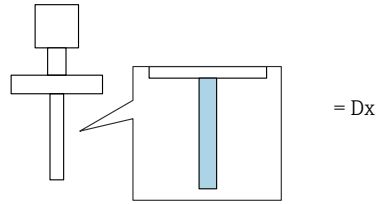

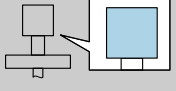
 = A	(1)	P1		P2		P3		P4		P5		P6		
		T _p	T _a	T _p	T _a	T _p	T _a	T _p	T _a	T _p	T _a	T _p	T _a	
	A, C	T6	-40	60	60	60	85	50	85	-40	-40	-40	-	-
		T5	-40	75	75	75	100	65	100	-40	-40	-40	-	-
		T4	-40	79	79	79	135	66	135	-40	-40	-40	-	-
		T3 ¹⁾	-40	79	79	79	150	60	150	-40	-40	-40	-	-
	B	T6	-40	60	60	60	85	50	85	-40	-40	-40	-	-
		T5	-40	72	72	72	100	65	100	-40	-40	-40	-	-
		T4	-40	72	72	72	135	58	135	-40	-40	-40	-	-
		T3 ¹⁾	-40	72	72	72	150	55	150	-40	-40	-40	-	-

1) Functional: Maximum permissible process temperature

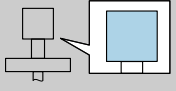
 = B	(1)	P1		P2		P3		P4		P5		P6		
		T _p	T _a	T _p	T _a	T _p	T _a	T _p	T _a	T _p	T _a	T _p	T _a	
	A, B, C	T6	-40	60	60	60	85	55	85	-40	-40	-40	-	-
		T5	-40	75	75	75	100	70	100	-40	-40	-40	-	-
		T4	-40	80	80	80	135	70	135	-40	-40	-40	-	-
		T3 ¹⁾	-40	80	80	80	150	68	150	-40	-40	-40	-	-
	K, L	T6	-40	60	60	60	85	55	85	-40	-40	-40	-	-
		T5	-40	75	75	75	100	70	100	-40	-40	-40	-	-
		T4	-40	76	76	76	135	66	135	-40	-40	-40	-	-
		T3 ¹⁾	-40	76	76	76	150	63	150	-40	-40	-40	-	-

1) Functional: Maximum permissible process temperature

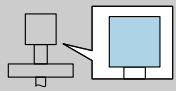
	(1)	P1		P2		P3		P4		P5		P6		
		T _p	T _a	T _p	T _a	T _p	T _a	T _p	T _a	T _p	T _a	T _p	T _a	
	A, B, C	T6	-40	60	60	60	85	56	85	-40	-40	-40	-	-
		T5	-40	75	75	75	100	71	100	-40	-40	-40	-	-
		T4	-40	80	80	80	135	72	135	-40	-40	-40	-	-
		T3 ¹⁾	-40	80	80	80	150	70	150	-40	-40	-40	-	-
	K, L	T6	-40	60	60	60	85	56	85	-40	-40	-40	-	-
		T5	-40	75	75	75	100	71	100	-40	-40	-40	-	-
		T4	-40	76	76	76	135	68	135	-40	-40	-40	-	-
		T3 ¹⁾	-40	76	76	76	150	66	150	-40	-40	-40	-	-

1) Functional: Maximum permissible process temperature

FMR56

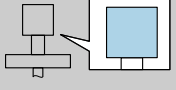
 = A	(1)	P1		P2		P3		P4		P5		P6		
		T _p	T _a	T _p	T _a	T _p	T _a	T _p	T _a	T _p	T _a	T _p	T _a	
	A, C	T6	-40	60	60	60	80	55	80	-40	-40	-40	-	-
	B	T6	-40	57	57	57	80	54	80	-40	-40	-40	-	-

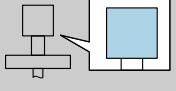
 = C	(1)	P1		P2		P3		P4		P5		P6		
		T _p	T _a	T _p	T _a	T _p	T _a	T _p	T _a	T _p	T _a	T _p	T _a	
	A, B, C	T6	-40	60	60	60	80	58	80	-40	-40	-40	-	-
	K, L	T6	-40	60	60	60	80	58	80	-40	-40	-40	-	-

FMR57

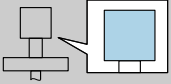
 = A	(1)	P1		P2		P3		P4		P5		P6		
		T _p	T _a	T _p	T _a	T _p	T _a	T _p	T _a	T _p	T _a	T _p	T _a	
	A, C	T6	-40	60	60	60	85	53	85	-40	-40	-40	-	-
		T5	-40	75	75	75	100	68	100	-40	-40	-40	-	-
		T4	-40	79	79	79	135	70	135	-40	-40	-40	-	-
		T3	-40	79	79	79	200	53	200	-40	-40	-40	-	-
	B	T6	-40	57	57	57	85	53	85	-40	-40	-40	-	-
		T5	-40	72	72	72	100	67	100	-40	-40	-40	-	-
		T4	-40	72	72	72	135	62	135	-40	-40	-40	-	-
		T3	-40	72	72	72	200	51	200	-40	-40	-40	-	-

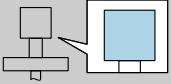
 = B	(1)	P1		P2		P3		P4		P5		P6		
		T _p	T _a	T _p	T _a	T _p	T _a	T _p	T _a	T _p	T _a	T _p	T _a	
	A, B, C	T6	-40	60	60	60	85	56	85	-40	-40	-40	-	-
		T5	-40	75	75	75	100	71	100	-40	-40	-40	-	-
		T4	-40	80	80	80	135	73	135	-40	-40	-40	-	-
		T3	-40	80	80	80	200	65	200	-40	-40	-40	-	-
	K, L	T6	-40	60	60	60	85	56	85	-40	-40	-40	-	-
		T5	-40	75	75	75	100	71	100	-40	-40	-40	-	-
		T4	-40	76	76	76	135	69	135	-40	-40	-40	-	-
		T3	-40	76	76	76	200	62	200	-40	-40	-40	-	-

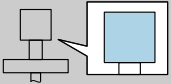
 = C	(1)	P1		P2		P3		P4		P5		P6		
		T _p	T _a	T _p	T _a	T _p	T _a	T _p	T _a	T _p	T _a	T _p	T _a	
	A, B, C	T6	-40	60	60	60	85	57	85	-40	-40	-40	-	-
		T5	-40	75	75	75	100	72	100	-40	-40	-40	-	-
		T4	-40	80	80	80	135	75	135	-40	-40	-40	-	-
		T3	-40	80	80	80	200	69	200	-40	-40	-40	-	-
	K, L	T6	-40	60	60	60	85	57	85	-40	-40	-40	-	-
		T5	-40	75	75	75	100	72	100	-40	-40	-40	-	-
		T4	-40	76	76	76	135	71	135	-40	-40	-40	-	-
		T3	-40	76	76	76	200	65	200	-40	-40	-40	-	-

FMR57

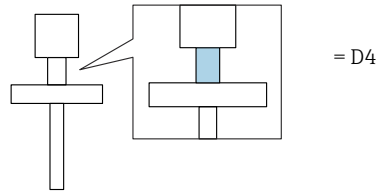

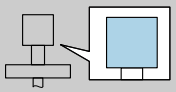
 = A	(1)	P1		P2		P3		P4		P5		P6		
		T _p	T _a	T _p	T _a	T _p	T _a	T _p	T _a	T _p	T _a	T _p	T _a	
	A, C	T6	-40	60	60	60	85	54	85	-40	-40	-40	-	-
		T5	-40	75	75	75	100	69	100	-40	-40	-40	-	-
		T4	-40	79	79	79	135	72	135	-40	-40	-40	-	-
		T3	-40	79	79	79	200	59	200	-40	-40	-40	-	-
		T2	-40	79	79	79	300	37	300	-40	-40	-40	-	-
	B	T6	-40	57	57	57	85	54	85	-40	-40	-40	-	-
		T5	-40	72	72	72	100	68	100	-40	-40	-40	-	-
		T4	-40	72	72	72	135	64	135	-40	-40	-40	-	-
		T3	-40	72	72	72	200	55	200	-40	-40	-40	-	-
		T2	-40	72	72	72	300	37	300	-40	-40	-40	-	-

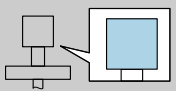
 = B	(1)	P1		P2		P3		P4		P5		P6		
		T _p	T _a	T _p	T _a	T _p	T _a	T _p	T _a	T _p	T _a	T _p	T _a	
	A, B, C	T6	-40	60	60	60	85	57	85	-40	-40	-40	-	-
		T5	-40	75	75	75	100	72	100	-40	-40	-40	-	-
		T4	-40	80	80	80	135	75	135	-40	-40	-40	-	-
		T3	-40	80	80	80	200	69	200	-40	-40	-40	-	-
		T2	-40	80	80	80	300	60	300	-40	-40	-40	-	-
		T1 ¹⁾	-40	80	80	80	400	51	400	-40	-40	-40	-	-
	K, L	T6	-40	60	60	60	85	57	85	-40	-40	-40	-	-
		T5	-40	75	75	75	100	72	100	-40	-40	-40	-	-
		T4	-40	76	76	76	135	71	135	-40	-40	-40	-	-
		T3	-40	76	76	76	200	65	200	-40	-40	-40	-	-
		T2	-40	76	76	76	300	56	300	-40	-40	-40	-	-
T1 ¹⁾	-40	76	76	76	400	47	400	-40	-40	-40	-	-		

1) Functional: Maximum permissible process temperature

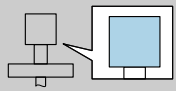
	(1)	P1		P2		P3		P4		P5		P6		
		T _p	T _a	T _p	T _a	T _p	T _a	T _p	T _a	T _p	T _a	T _p	T _a	
	A, B, C	T6	-40	60	60	60	85	58	85	-40	-40	-40	-	-
		T5	-40	75	75	75	100	73	100	-40	-40	-40	-	-
		T4	-40	80	80	80	135	76	135	-40	-40	-40	-	-
		T3	-40	80	80	80	200	71	200	-40	-40	-40	-	-
		T2	-40	80	80	80	300	64	300	-40	-40	-40	-	-
		T1 ¹⁾	-40	80	80	80	400	57	400	-40	-40	-40	-	-
	K, L	T6	-40	60	60	60	85	58	85	-40	-40	-40	-	-
		T5	-40	75	75	75	100	73	100	-40	-40	-40	-	-
		T4	-40	76	76	76	135	72	135	-40	-40	-40	-	-
		T3	-40	76	76	76	200	68	200	-40	-40	-40	-	-
		T2	-40	76	76	76	300	61	300	-40	-40	-40	-	-
		T1 ¹⁾	-40	76	76	76	400	53	400	-40	-40	-40	-	-

1) Functional: Maximum permissible process temperature

Zone 2: 2 channels

Position 3 (Power Supply, Output) = B, C: 2 channels used

Page references to the temperature tables of the respective device types: See the following list.

- FMR50 → 46
- FMR51 → 47
- FMR52 → 52
- FMR53 → 56
- FMR54 → 58
- FMR56 → 65
- FMR57 → 66

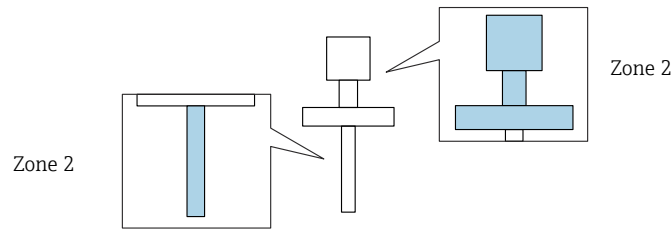

FMR50

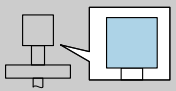
 = A	(2)	P1		P2		P3		P4		P5		P6		
		T _p	T _a	T _p	T _a	T _p	T _a	T _p	T _a	T _p	T _a	T _p	T _a	
	B	T6	-40	43	43	43	80	38	80	-40	-40	-40	-	-
	C	T6	-40	60	60	60	80	55	80	-40	-40	-40	-	-

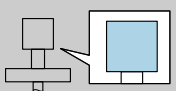
 = C	(2)	P1		P2		P3		P4		P5		P6		
		T _p	T _a	T _p	T _a	T _p	T _a	T _p	T _a	T _p	T _a	T _p	T _a	
	B	T6	-40	51	51	51	80	49	80	-40	-40	-40	-	-
	C	T6	-40	60	60	60	80	58	80	-40	-40	-40	-	-

FMR51

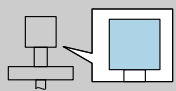
 = A	(2)	P1		P2		P3		P4		P5		P6		
		T _p	T _a	T _p	T _a	T _p	T _a	T _p	T _a	T _p	T _a	T _p	T _a	
	B	T6	-40	43	43	43	85	33	85	-40	-40	-40	-	-
		T5	-40	56	56	56	100	46	100	-40	-40	-40	-	-
		T4	-40	56	56	56	135	37	135	-40	-40	-40	-	-
		T3 ¹⁾	-40	56	56	56	150	33	150	-40	-40	-40	-	-
	C	T6	-40	60	60	60	85	49	85	-40	-40	-40	-	-
		T5	-40	75	75	75	100	64	100	-40	-40	-40	-	-
		T4	-40	76	76	76	135	61	135	-40	-40	-40	-	-
		T3 ¹⁾	-40	76	76	76	150	56	150	-40	-40	-40	-	-

1) Functional: Maximum permissible process temperature

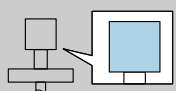
 = B	(2)	P1		P2		P3		P4		P5		P6		
		T _p	T _a	T _p	T _a	T _p	T _a	T _p	T _a	T _p	T _a	T _p	T _a	
	B	T6	-40	51	51	51	85	44	85	-40	-40	-40	-	-
		T5	-40	66	66	66	100	59	100	-40	-40	-40	-	-
		T4	-40	75	75	75	135	62	135	-40	-40	-40	-	-
		T3 ¹⁾	-40	75	75	75	150	59	150	-40	-40	-40	-	-
	C	T6	-40	60	60	60	85	54	85	-40	-40	-40	-	-
		T5	-40	75	75	75	100	69	100	-40	-40	-40	-	-
		T4	-40	78	78	78	135	66	135	-40	-40	-40	-	-
		T3 ¹⁾	-40	78	78	78	150	63	150	-40	-40	-40	-	-

1) Functional: Maximum permissible process temperature

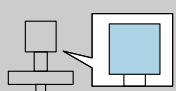
 = C	(2)	P1		P2		P3		P4		P5		P6		
		T _p	T _a	T _p	T _a	T _p	T _a	T _p	T _a	T _p	T _a	T _p	T _a	
	B	T6	-40	51	51	51	85	45	85	-40	-40	-40	-	-
		T5	-40	66	66	66	100	60	100	-40	-40	-40	-	-
		T4	-40	75	75	75	135	65	135	-40	-40	-40	-	-
		T3 ¹⁾	-40	75	75	75	150	62	150	-40	-40	-40	-	-
	C	T6	-40	60	60	60	85	55	85	-40	-40	-40	-	-
		T5	-40	75	75	75	100	70	100	-40	-40	-40	-	-
		T4	-40	78	78	78	135	68	135	-40	-40	-40	-	-
		T3 ¹⁾	-40	78	78	78	150	66	150	-40	-40	-40	-	-

1) Functional: Maximum permissible process temperature

FMR51

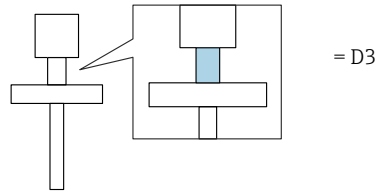

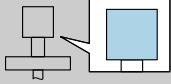
 = A	(2)	P1		P2		P3		P4		P5		P6		
		T _p	T _a	T _p	T _a	T _p	T _a	T _p	T _a	T _p	T _a	T _p	T _a	
	B	T6	-40	43	43	43	85	37	85	-40	-40	-40	-	-
		T5	-40	56	56	56	100	50	100	-40	-40	-40	-	-
		T4	-40	56	56	56	135	45	135	-40	-40	-40	-	-
		T3	-40	56	56	56	200	35	200	-40	-40	-40	-	-
	C	T6	-40	60	60	60	85	54	85	-40	-40	-40	-	-
		T5	-40	75	75	75	100	69	100	-40	-40	-40	-	-
		T4	-40	76	76	76	135	67	135	-40	-40	-40	-	-
		T3	-40	76	76	76	200	56	200	-40	-40	-40	-	-
		T2 ¹⁾	-40	76	76	76	250	44	250	-40	-40	-40	-	-

1) Functional: Maximum permissible process temperature

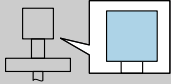
 = B	(2)	P1		P2		P3		P4		P5		P6		
		T _p	T _a	T _p	T _a	T _p	T _a	T _p	T _a	T _p	T _a	T _p	T _a	
	B	T6	-40	51	51	51	85	48	85	-40	-40	-40	-	-
		T5	-40	66	66	66	100	63	100	-40	-40	-40	-	-
		T4	-40	75	75	75	135	69	135	-40	-40	-40	-	-
		T3	-40	75	75	75	200	62	200	-40	-40	-40	-	-
		T2 ¹⁾	-40	75	75	75	250	57	250	-40	-40	-40	-	-
	C	T6	-40	60	60	60	85	57	85	-40	-40	-40	-	-
		T5	-40	75	75	75	100	72	100	-40	-40	-40	-	-
		T4	-40	78	78	78	135	72	135	-40	-40	-40	-	-
		T3	-40	78	78	78	200	65	200	-40	-40	-40	-	-
		T2 ¹⁾	-40	78	78	78	250	60	250	-40	-40	-40	-	-

1) Functional: Maximum permissible process temperature

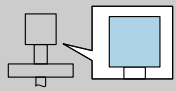
	(2)	P1		P2		P3		P4		P5		P6		
		T _p	T _a	T _p	T _a	T _p	T _a	T _p	T _a	T _p	T _a	T _p	T _a	
	B	T6	-40	51	51	51	85	48	85	-40	-40	-40	-	-
		T5	-40	66	66	66	100	63	100	-40	-40	-40	-	-
		T4	-40	75	75	75	135	70	135	-40	-40	-40	-	-
		T3	-40	75	75	75	200	65	200	-40	-40	-40	-	-
		T2 ¹⁾	-40	75	75	75	250	60	250	-40	-40	-40	-	-
	C	T6	-40	60	60	60	85	58	85	-40	-40	-40	-	-
		T5	-40	75	75	75	100	73	100	-40	-40	-40	-	-
		T4	-40	78	78	78	135	73	135	-40	-40	-40	-	-
		T3	-40	78	78	78	200	68	200	-40	-40	-40	-	-
		T2 ¹⁾	-40	78	78	78	250	64	250	-40	-40	-40	-	-

1) Functional: Maximum permissible process temperature

FMR51

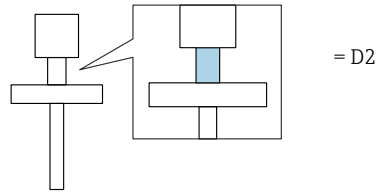

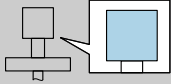
 = A	(2)	P1		P2		P3		P4		P5		P6		
		T _p	T _a	T _p	T _a	T _p	T _a	T _p	T _a	T _p	T _a	T _p	T _a	
	B	T6	-196	43	43	43	85	36	85	-40	-40	-40	-196	9
		T5	-196	56	56	56	100	48	100	-40	-40	-40	-196	9
		T4	-196	56	56	56	135	42	135	-40	-40	-40	-196	9
		T3	-196	56	56	56	200	30	200	-40	-40	-40	-196	9
	C	T6	-196	60	60	60	85	52	85	-40	-40	-40	-196	9
		T5	-196	75	75	75	100	67	100	-40	-40	-40	-196	9
		T4	-196	76	76	76	135	65	135	-40	-40	-40	-196	9
		T3	-196	76	76	76	200	49	200	-40	-40	-40	-196	9

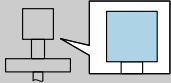
 = B	(2)	P1		P2		P3		P4		P5		P6		
		T _p	T _a	T _p	T _a	T _p	T _a	T _p	T _a	T _p	T _a	T _p	T _a	
	B	T6	-196	51	51	51	85	47	85	-40 -50 ¹⁾	-40 -50 ¹⁾	-40 -50 ¹⁾	-196	-15
		T5	-196	66	66	66	100	62	100	-40 -50 ¹⁾	-40 -50 ¹⁾	-40 -50 ¹⁾	-196	-15
		T4	-196	75	75	75	135	67	135	-40 -50 ¹⁾	-40 -50 ¹⁾	-40 -50 ¹⁾	-196	-15
		T3	-196	75	75	75	200	58	200	-40 -50 ¹⁾	-40 -50 ¹⁾	-40 -50 ¹⁾	-196	-15
		T2	-196	75	75	75	300	44	300	-40 -50 ¹⁾	-40 -50 ¹⁾	-40 -50 ¹⁾	-196	-15
	C	T6	-196	60	60	60	85	56	85	-40 -50 ¹⁾	-40 -50 ¹⁾	-40 -50 ¹⁾	-196	-15
		T5	-196	75	75	75	100	71	100	-40 -50 ¹⁾	-40 -50 ¹⁾	-40 -50 ¹⁾	-196	-15
		T4	-196	78	78	78	135	70	135	-40 -50 ¹⁾	-40 -50 ¹⁾	-40 -50 ¹⁾	-196	-15
		T3	-196	78	78	78	200	61	200	-40 -50 ¹⁾	-40 -50 ¹⁾	-40 -50 ¹⁾	-196	-15
		T2	-196	78	78	78	300	48	300	-40 -50 ¹⁾	-40 -50 ¹⁾	-40 -50 ¹⁾	-196	-15

1) Only in connection with Optional specification, ID Jx (Test, Certificate) = JN

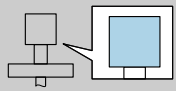
	(2)		P1		P2		P3		P4		P5		P6	
			T _p	T _a	T _p	T _a	T _p	T _a	T _p	T _a	T _p	T _a	T _p	T _a
	B	T6	-196	51	51	51	85	48	85	-40 -50 ¹⁾	-40 -50 ¹⁾	-40 -50 ¹⁾	-196	-20 -28 ¹⁾
		T5	-196	66	66	66	100	63	100	-40 -50 ¹⁾	-40 -50 ¹⁾	-40 -50 ¹⁾	-196	-20 -28 ¹⁾
		T4	-196	75	75	75	135	68	135	-40 -50 ¹⁾	-40 -50 ¹⁾	-40 -50 ¹⁾	-196	-20 -28 ¹⁾
		T3	-196	75	75	75	200	61	200	-40 -50 ¹⁾	-40 -50 ¹⁾	-40 -50 ¹⁾	-196	-20 -28 ¹⁾
		T2	-196	75	75	75	300	51	300	-40 -50 ¹⁾	-40 -50 ¹⁾	-40 -50 ¹⁾	-196	-20 -28 ¹⁾
		T1	-196	75	75	75	450	34	450	-40 -50 ¹⁾	-40 -50 ¹⁾	-40 -50 ¹⁾	-196	-20 -28 ¹⁾
	C	T6	-196	60	60	60	85	57	85	-40 -50 ¹⁾	-40 -50 ¹⁾	-40 -50 ¹⁾	-196	-20 -28 ¹⁾
		T5	-196	75	75	75	100	72	100	-40 -50 ¹⁾	-40 -50 ¹⁾	-40 -50 ¹⁾	-196	-20 -28 ¹⁾
		T4	-196	78	78	78	135	72	135	-40 -50 ¹⁾	-40 -50 ¹⁾	-40 -50 ¹⁾	-196	-20 -28 ¹⁾
		T3	-196	78	78	78	200	65	200	-40 -50 ¹⁾	-40 -50 ¹⁾	-40 -50 ¹⁾	-196	-20 -28 ¹⁾
		T2	-196	78	78	78	300	54	300	-40 -50 ¹⁾	-40 -50 ¹⁾	-40 -50 ¹⁾	-196	-20 -28 ¹⁾
		T1	-196	78	78	78	450	38	450	-40 -50 ¹⁾	-40 -50 ¹⁾	-40 -50 ¹⁾	-196	-20 -28 ¹⁾

1) Only in connection with Optional specification, ID Jx (Test, Certificate) = JN

FMR52

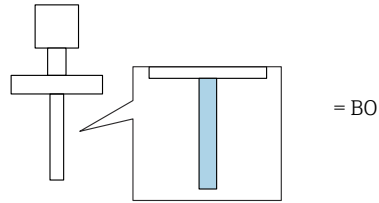

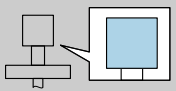
 = A	(2)	P1		P2		P3		P4		P5		P6		
		T _p	T _a	T _p	T _a	T _p	T _a	T _p	T _a	T _p	T _a	T _p	T _a	
	B	T6	-40	43	43	43	85	35	85	-40	-40	-40	-	-
		T5	-40	56	56	56	100	47	100	-40	-40	-40	-	-
		T4	-40	56	56	56	135	40	135	-40	-40	-40	-	-
	C	T6	-40	60	60	60	85	51	85	-40	-40	-40	-	-
		T5	-40	75	75	75	100	66	100	-40	-40	-40	-	-
		T4	-40	76	76	76	135	63	135	-40	-40	-40	-	-
		T3	-40	76	76	76	200	42	200	-40	-40	-40	-	-

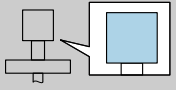
 = B	(2)	P1		P2		P3		P4		P5		P6		
		T _p	T _a	T _p	T _a	T _p	T _a	T _p	T _a	T _p	T _a	T _p	T _a	
	B	T6	-196	51	51	51	85	45	85	-40 -50 ¹⁾	-40 -50 ¹⁾	-40 -50 ¹⁾	-196	-3
		T5	-196	66	66	66	100	60	100	-40 -50 ¹⁾	-40 -50 ¹⁾	-40 -50 ¹⁾	-196	-3
		T4	-196	75	75	75	135	65	135	-40 -50 ¹⁾	-40 -50 ¹⁾	-40 -50 ¹⁾	-196	-3
		T3	-196	75	75	75	200	53	200	-40 -50 ¹⁾	-40 -50 ¹⁾	-40 -50 ¹⁾	-196	-3
	C	T6	-196	60	60	60	85	55	85	-40 -50 ¹⁾	-40 -50 ¹⁾	-40 -50 ¹⁾	-196	-3
		T5	-196	75	75	75	100	70	100	-40 -50 ¹⁾	-40 -50 ¹⁾	-40 -50 ¹⁾	-196	-3
		T4	-196	78	78	78	135	68	135	-40 -50 ¹⁾	-40 -50 ¹⁾	-40 -50 ¹⁾	-196	-3
		T3	-196	78	78	78	200	57	200	-40 -50 ¹⁾	-40 -50 ¹⁾	-40 -50 ¹⁾	-196	-3

1) Only in connection with Optional specification, ID Jx (Test, Certificate) = JN

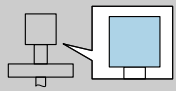
	(2)		P1		P2		P3		P4		P5		P6	
			T _p	T _a	T _p	T _a	T _p	T _a	T _p	T _a	T _p	T _a	T _p	T _a
	B	T6	-196	51	51	51	85	47	85	-40 -50 ¹⁾	-40 -50 ¹⁾	-40 -50 ¹⁾	-196	-14
		T5	-196	66	66	66	100	62	100	-40 -50 ¹⁾	-40 -50 ¹⁾	-40 -50 ¹⁾	-196	-14
		T4	-196	75	75	75	135	67	135	-40 -50 ¹⁾	-40 -50 ¹⁾	-40 -50 ¹⁾	-196	-14
		T3	-196	75	75	75	200	58	200	-40 -50 ¹⁾	-40 -50 ¹⁾	-40 -50 ¹⁾	-196	-14
	C	T6	-196	60	60	60	85	56	85	-40 -50 ¹⁾	-40 -50 ¹⁾	-40 -50 ¹⁾	-196	-14
		T5	-196	75	75	75	100	71	100	-40 -50 ¹⁾	-40 -50 ¹⁾	-40 -50 ¹⁾	-196	-14
		T4	-196	78	78	78	135	70	135	-40 -50 ¹⁾	-40 -50 ¹⁾	-40 -50 ¹⁾	-196	-14
		T3	-196	78	78	78	200	61	200	-40 -50 ¹⁾	-40 -50 ¹⁾	-40 -50 ¹⁾	-196	-14

1) Only in connection with Optional specification, ID Jx (Test, Certificate) = JN

FMR52

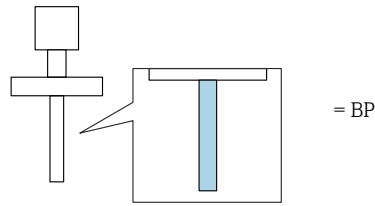

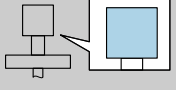
 = A	(2)		P1		P2		P3		P4		P5		P6	
			T _p	T _a	T _p	T _a	T _p	T _a	T _p	T _a	T _p	T _a	T _p	T _a
	B	T6	-40	43	43	43	85	33	85	-40	-40	-40	-	-
		T5	-40	56	56	56	100	46	100	-40	-40	-40	-	-
		T4	-40	56	56	56	135	38	135	-40	-40	-40	-	-
	C	T6	-40	60	60	60	85	49	85	-40	-40	-40	-	-
		T5	-40	75	75	75	100	64	100	-40	-40	-40	-	-
		T4	-40	76	76	76	135	61	135	-40	-40	-40	-	-
		T3	-40	76	76	76	200	36	200	-40	-40	-40	-	-

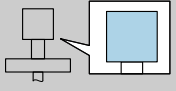
 = B	(2)		P1		P2		P3		P4		P5		P6	
			T _p	T _a	T _p	T _a	T _p	T _a	T _p	T _a	T _p	T _a	T _p	T _a
	B	T6	-196	51	51	51	85	44	85	-40 -50 ¹⁾	-40 -50 ¹⁾	-40 -50 ¹⁾	-196	10
		T5	-196	66	66	66	100	59	100	-40 -50 ¹⁾	-40 -50 ¹⁾	-40 -50 ¹⁾	-196	10
		T4	-196	75	75	75	135	63	135	-40 -50 ¹⁾	-40 -50 ¹⁾	-40 -50 ¹⁾	-196	10
		T3	-196	75	75	75	200	49	200	-40 -50 ¹⁾	-40 -50 ¹⁾	-40 -50 ¹⁾	-196	10
	C	T6	-196	60	60	60	85	54	85	-40 -50 ¹⁾	-40 -50 ¹⁾	-40 -50 ¹⁾	-196	10
		T5	-196	75	75	75	100	69	100	-40 -50 ¹⁾	-40 -50 ¹⁾	-40 -50 ¹⁾	-196	10
		T4	-196	78	78	78	135	66	135	-40 -50 ¹⁾	-40 -50 ¹⁾	-40 -50 ¹⁾	-196	10
T3		-196	78	78	78	200	53	200	-40 -50 ¹⁾	-40 -50 ¹⁾	-40 -50 ¹⁾	-196	10	

1) Only in connection with Optional specification, ID Jx (Test, Certificate) = JN

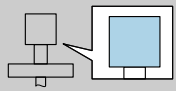
	(2)		P1		P2		P3		P4		P5		P6	
			T _p	T _a	T _p	T _a	T _p	T _a	T _p	T _a	T _p	T _a	T _p	T _a
	B	T6	-196	51	51	51	85	46	85	-40 -50 ¹⁾	-40 -50 ¹⁾	-40 -50 ¹⁾	-196	-8
		T5	-196	66	66	66	100	61	100	-40 -50 ¹⁾	-40 -50 ¹⁾	-40 -50 ¹⁾	-196	-8
		T4	-196	75	75	75	135	65	135	-40 -50 ¹⁾	-40 -50 ¹⁾	-40 -50 ¹⁾	-196	-8
		T3	-196	75	75	75	200	54	200	-40 -50 ¹⁾	-40 -50 ¹⁾	-40 -50 ¹⁾	-196	-8
	C	T6	-196	60	60	60	85	55	85	-40 -50 ¹⁾	-40 -50 ¹⁾	-40 -50 ¹⁾	-196	-8
		T5	-196	75	75	75	100	70	100	-40 -50 ¹⁾	-40 -50 ¹⁾	-40 -50 ¹⁾	-196	-8
		T4	-196	78	78	78	135	69	135	-40 -50 ¹⁾	-40 -50 ¹⁾	-40 -50 ¹⁾	-196	-8
		T3	-196	78	78	78	200	58	200	-40 -50 ¹⁾	-40 -50 ¹⁾	-40 -50 ¹⁾	-196	-8

1) Only in connection with Optional specification, ID Jx (Test, Certificate) = JN

FMR53

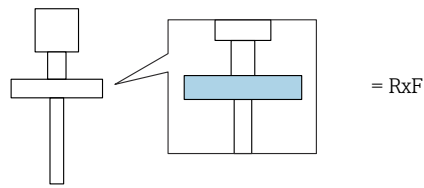

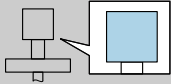
 = A	(2)		P1		P2		P3		P4		P5		P6	
			T _p	T _a	T _p	T _a	T _p	T _a	T _p	T _a	T _p	T _a	T _p	T _a
	B	T6	-40	43	43	43	80	39	80	-40	-40	-40	-	-
	C	T6	-40	60	60	60	80	56	80	-40	-40	-40	-	-

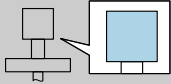
 = B, C	(2)		P1		P2		P3		P4		P5		P6	
			T _p	T _a	T _p	T _a	T _p	T _a	T _p	T _a	T _p	T _a	T _p	T _a
	B	T6	-40	51	51	51	80	49	80	-40	-40	-40	-	-
	C	T6	-40	60	60	60	80	58	80	-40	-40	-40	-	-

FMR53

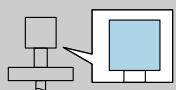
 = A	(2)	P1		P2		P3		P4		P5		P6		
		T _p	T _a	T _p	T _a	T _p	T _a	T _p	T _a	T _p	T _a	T _p	T _a	
	B	T6	-40	43	43	43	85	33	85	-40	-40	-40	-	-
		T5	-40	56	56	56	100	45	100	-40	-40	-40	-	-
		T4	-40	56	56	56	135	36	135	-20	-40	-40	-	-
		T3 ¹⁾	-40	56	56	56	150	32	150	-20	-40	-40	-	-
	C	T6	-40	60	60	60	85	48	85	-40	-40	-40	-	-
		T5	-40	75	75	75	100	63	100	-40	-40	-40	-	-
		T4	-40	76	76	76	135	30	135	-40	-40	-40	-	-
		T3 ¹⁾	-40	76	76	76	150	55	150	-40	-40	-40	-	-

1) Functional: Maximum permissible process temperature

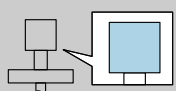
 = B	(2)	P1		P2		P3		P4		P5		P6		
		T _p	T _a	T _p	T _a	T _p	T _a	T _p	T _a	T _p	T _a	T _p	T _a	
	B	T6	-40	51	51	51	85	43	85	-40	-40	-40	-	-
		T5	-40	66	66	66	100	58	100	-40	-40	-40	-	-
		T4	-40	75	75	75	135	61	135	-40	-40	-40	-	-
		T3 ¹⁾	-40	75	75	75	150	58	150	-40	-40	-40	-	-
	C	T6	-40	60	60	60	85	53	85	-40	-40	-40	-	-
		T5	-40	75	75	75	100	68	100	-40	-40	-40	-	-
		T4	-40	78	78	78	135	65	135	-40	-40	-40	-	-
		T3 ¹⁾	-40	78	78	78	150	61	150	-40	-40	-40	-	-

1) Functional: Maximum permissible process temperature

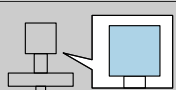
 = C	(2)	P1		P2		P3		P4		P5		P6		
		T _p	T _a	T _p	T _a	T _p	T _a	T _p	T _a	T _p	T _a	T _p	T _a	
	B	T6	-40	51	51	51	85	45	85	-40	-40	-40	-	-
		T5	-40	66	66	66	100	60	100	-40	-40	-40	-	-
		T4	-40	75	75	75	135	64	135	-40	-40	-40	-	-
		T3 ¹⁾	-40	75	75	75	150	61	150	-40	-40	-40	-	-
	C	T6	-40	60	60	60	85	54	85	-40	-40	-40	-	-
		T5	-40	75	75	75	100	69	100	-40	-40	-40	-	-
		T4	-40	78	78	78	135	67	135	-40	-40	-40	-	-
		T3 ¹⁾	-40	78	78	78	150	64	150	-40	-40	-40	-	-

1) Functional: Maximum permissible process temperature

FMR54

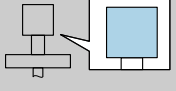
 = A	(2)	P1		P2		P3		P4		P5		P6		
		T _p	T _a	T _p	T _a	T _p	T _a	T _p	T _a	T _p	T _a	T _p	T _a	
	B	T6	-40	43	43	43	85	32	85	-40	-40	-40	-	-
		T5	-40	56	56	56	100	45	100	-40	-40	-40	-	-
		T4	-40	56	56	56	135	35	135	-40	-40	-40	-	-
	C	T6	-40	60	60	60	85	48	85	-40	-40	-40	-	-
		T5	-40	75	75	75	100	63	100	-40	-40	-40	-	-
		T4	-40	76	76	76	135	60	135	-40	-40	-40	-	-

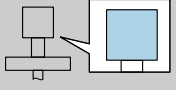
 = B	(2)	P1		P2		P3		P4		P5		P6		
		T _p	T _a	T _p	T _a	T _p	T _a	T _p	T _a	T _p	T _a	T _p	T _a	
	B	T6	-40	51	51	51	85	43	85	-40	-40	-40	-	-
		T5	-40	66	66	66	100	58	100	-40	-40	-40	-	-
		T4	-40	75	75	75	135	60	135	-40	-40	-40	-	-
		T3	-40	75	75	75	200	45	200	-40	-40	-40	-	-
	C	T6	-40	60	60	60	85	53	85	-40	-40	-40	-	-
		T5	-40	75	75	75	100	68	100	-40	-40	-40	-	-
		T4	-40	78	78	78	135	64	135	-40	-40	-40	-	-
		T3	-40	78	78	78	200	48	200	-40	-40	-40	-	-

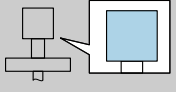
 = C	(2)	P1		P2		P3		P4		P5		P6		
		T _p	T _a	T _p	T _a	T _p	T _a	T _p	T _a	T _p	T _a	T _p	T _a	
	B	T6	-40	51	51	51	85	44	85	-40	-40	-40	-	-
		T5	-40	66	66	66	100	59	100	-40	-40	-40	-	-
		T4	-40	75	75	75	135	63	135	-40	-40	-40	-	-
		T3	-40	75	75	75	200	50	200	-40	-40	-40	-	-
	C	T6	-40	60	60	60	85	54	85	-40	-40	-40	-	-
		T5	-40	75	75	75	100	69	100	-40	-40	-40	-	-
		T4	-40	78	78	78	135	67	135	-40	-40	-40	-	-
		T3	-40	78	78	78	200	54	200	-40	-40	-40	-	-

FMR54

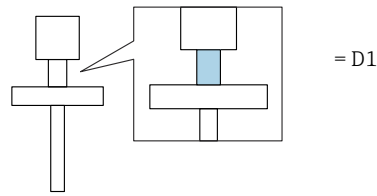

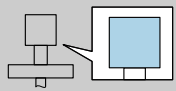
 = A	(2)		P1		P2		P3		P4		P5		P6	
			T _p	T _a	T _p	T _a	T _p	T _a	T _p	T _a	T _p	T _a	T _p	T _a
	B	T6	-196	43	43	43	85	35	85	-40	-40	-40	-196	18
		T5	-196	56	56	56	100	47	100	-40	-40	-40	-196	18
		T4	-196	56	56	56	135	40	135	-40	-40	-40	-196	18
	C	T6	-196	60	60	60	85	51	85	-40	-40	-40	-196	18
		T5	-196	75	75	75	100	66	100	-40	-40	-40	-196	18
		T4	-196	76	76	76	135	63	135	-40	-40	-40	-196	18
		T3	-196	76	76	76	200	42	200	-40	-40	-40	-196	18

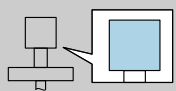
 = B	(2)		P1		P2		P3		P4		P5		P6	
			T _p	T _a	T _p	T _a	T _p	T _a	T _p	T _a	T _p	T _a	T _p	T _a
	B	T6	-196	51	51	51	85	45	85	-40 -50 ¹⁾	-40 -50 ¹⁾	-40 -50 ¹⁾	-196	-4
		T5	-196	66	66	66	100	60	100	-40 -50 ¹⁾	-40 -50 ¹⁾	-40 -50 ¹⁾	-196	-4
		T4	-196	75	75	75	135	65	135	-40 -50 ¹⁾	-40 -50 ¹⁾	-40 -50 ¹⁾	-196	-4
		T3	-196	75	75	75	200	54	200	-40 -50 ¹⁾	-40 -50 ¹⁾	-40 -50 ¹⁾	-196	-4
		T2 ²⁾	-196	75	75	75	280	40	280	-40 -50 ¹⁾	-40 -50 ¹⁾	-40 -50 ¹⁾	-196	-4
	C	T6	-196	60	60	60	85	55	85	-40 -50 ¹⁾	-40 -50 ¹⁾	-40 -50 ¹⁾	-196	-4
		T5	-196	75	75	75	100	70	100	-40 -50 ¹⁾	-40 -50 ¹⁾	-40 -50 ¹⁾	-196	-4
		T4	-196	78	78	78	135	68	135	-40 -50 ¹⁾	-40 -50 ¹⁾	-40 -50 ¹⁾	-196	-4
		T3	-196	78	78	78	200	57	200	-40 -50 ¹⁾	-40 -50 ¹⁾	-40 -50 ¹⁾	-196	-4
		T2 ²⁾	-196	78	78	78	280	44	280	-40 -50 ¹⁾	-40 -50 ¹⁾	-40 -50 ¹⁾	-196	-4

1) Only in connection with Optional specification, ID Jx (Test, Certificate) = JN
 2) Functional: Maximum permissible process temperature

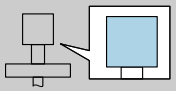
 = C	(2)	P1		P2		P3		P4		P5		P6		
		T _p	T _a	T _p	T _a	T _p	T _a	T _p	T _a	T _p	T _a	T _p	T _a	
	B	T6	-196	51	51	51	85	47	85	-40 -50 ¹⁾	-40 -50 ¹⁾	-40 -50 ¹⁾	-196	-15
		T5	-196	66	66	66	100	62	100	-40 -50 ¹⁾	-40 -50 ¹⁾	-40 -50 ¹⁾	-196	-15
		T4	-196	75	75	75	135	67	135	-40 -50 ¹⁾	-40 -50 ¹⁾	-40 -50 ¹⁾	-196	-15
		T3	-196	75	75	75	200	58	200	-40 -50 ¹⁾	-40 -50 ¹⁾	-40 -50 ¹⁾	-196	-15
		T2 ²⁾	-196	75	75	75	280	47	280	-40 -50 ¹⁾	-40 -50 ¹⁾	-40 -50 ¹⁾	-196	-15
	C	T6	-196	60	60	60	85	56	85	-40 -50 ¹⁾	-40 -50 ¹⁾	-40 -50 ¹⁾	-196	-15
		T5	-196	75	75	75	100	71	100	-40 -50 ¹⁾	-40 -50 ¹⁾	-40 -50 ¹⁾	-196	-15
		T4	-196	78	78	78	135	70	135	-40 -50 ¹⁾	-40 -50 ¹⁾	-40 -50 ¹⁾	-196	-15
		T3	-196	78	78	78	200	61	200	-40 -50 ¹⁾	-40 -50 ¹⁾	-40 -50 ¹⁾	-196	-15
		T2 ²⁾	-196	78	78	78	280	51	280	-40 -50 ¹⁾	-40 -50 ¹⁾	-40 -50 ¹⁾	-196	-15

1) Only in connection with Optional specification, ID Jx (Test, Certificate) = JN

2) Functional: Maximum permissible process temperature

FMR54

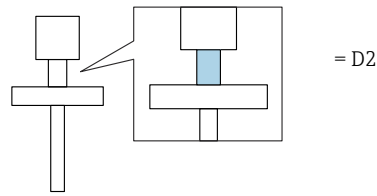

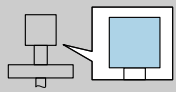
 = A	(2)	P1		P2		P3		P4		P5		P6		
		T _p	T _a	T _p	T _a	T _p	T _a	T _p	T _a	T _p	T _a	T _p	T _a	
	B	T6	-196	43	43	43	85	36	85	-40	-40	-40	-196	11
		T5	-196	56	56	56	100	48	100	-40	-40	-40	-196	11
		T4	-196	56	56	56	135	41	135	-40	-40	-40	-196	11
	C	T6	-196	60	60	60	85	52	85	-40	-40	-40	-196	11
		T5	-196	75	75	75	100	67	100	-40	-40	-40	-196	11
		T4	-196	76	76	76	135	64	135	-40	-40	-40	-196	11
		T3	-196	76	76	76	200	47	200	-40	-40	-40	-196	11

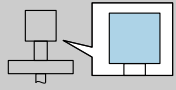
 = B	(2)	P1		P2		P3		P4		P5		P6		
		T _p	T _a	T _p	T _a	T _p	T _a	T _p	T _a	T _p	T _a	T _p	T _a	
	B	T6	-196	51	51	51	85	46	85	-40 -50 ¹⁾	-40 -50 ¹⁾	-40 -50 ¹⁾	-196	-13
		T5	-196	66	66	66	100	61	100	-40 -50 ¹⁾	-40 -50 ¹⁾	-40 -50 ¹⁾	-196	-13
		T4	-196	75	75	75	135	66	135	-40 -50 ¹⁾	-40 -50 ¹⁾	-40 -50 ¹⁾	-196	-13
		T3	-196	75	75	75	200	57	200	-40 -50 ¹⁾	-40 -50 ¹⁾	-40 -50 ¹⁾	-196	-13
		T2	-196	75	75	75	300	42	300	-40 -50 ¹⁾	-40 -50 ¹⁾	-40 -50 ¹⁾	-196	-13
	C	T6	-196	60	60	60	85	56	85	-40 -50 ¹⁾	-40 -50 ¹⁾	-40 -50 ¹⁾	-196	-13
		T5	-196	75	75	75	100	71	100	-40 -50 ¹⁾	-40 -50 ¹⁾	-40 -50 ¹⁾	-196	-13
		T4	-196	78	78	78	135	70	135	-40 -50 ¹⁾	-40 -50 ¹⁾	-40 -50 ¹⁾	-196	-13
		T3	-196	78	78	78	200	60	200	-40 -50 ¹⁾	-40 -50 ¹⁾	-40 -50 ¹⁾	-196	-13
		T2	-196	78	78	78	300	46	300	-40 -50 ¹⁾	-40 -50 ¹⁾	-40 -50 ¹⁾	-196	-13
		T1 ²⁾	-196	78	78	78	400	31	400	-40 -50 ¹⁾	-40 -50 ¹⁾	-40 -50 ¹⁾	-196	-13

1) Only in connection with Optional specification, ID Jx (Test, Certificate) = JN
 2) Functional: Maximum permissible process temperature

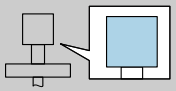
 = C	(2)	P1		P2		P3		P4		P5		P6		
		T _p	T _a	T _p	T _a	T _p	T _a	T _p	T _a	T _p	T _a	T _p	T _a	
	B	T6	-196	51	51	51	85	47	85	-40 -50 ¹⁾	-40 -50 ¹⁾	-40 -50 ¹⁾	-196	-19 -26 ¹⁾
		T5	-196	66	66	66	100	62	100	-40 -50 ¹⁾	-40 -50 ¹⁾	-40 -50 ¹⁾	-196	-19 -26 ¹⁾
		T4	-196	75	75	75	135	68	135	-40 -50 ¹⁾	-40 -50 ¹⁾	-40 -50 ¹⁾	-196	-19 -26 ¹⁾
		T3	-196	75	75	75	200	60	200	-40 -50 ¹⁾	-40 -50 ¹⁾	-40 -50 ¹⁾	-196	-19 -26 ¹⁾
		T2	-196	75	75	75	300	49	300	-40 -50 ¹⁾	-40 -50 ¹⁾	-40 -50 ¹⁾	-196	-19 -26 ¹⁾
		T1 ²⁾	-196	75	75	75	400	37	400	-40 -50 ¹⁾	-40 -50 ¹⁾	-40 -50 ¹⁾	-196	-19 -26 ¹⁾
	C	T6	-196	60	60	60	85	57	85	-40 -50 ¹⁾	-40 -50 ¹⁾	-40 -50 ¹⁾	-196	-19 -26 ¹⁾
		T5	-196	75	75	75	100	72	100	-40 -50 ¹⁾	-40 -50 ¹⁾	-40 -50 ¹⁾	-196	-19 -26 ¹⁾
		T4	-196	78	78	78	135	71	135	-40 -50 ¹⁾	-40 -50 ¹⁾	-40 -50 ¹⁾	-196	-19 -26 ¹⁾
		T3	-196	78	78	78	200	64	200	-40 -50 ¹⁾	-40 -50 ¹⁾	-40 -50 ¹⁾	-196	-19 -26 ¹⁾
		T2	-196	78	78	78	300	52	300	-40 -50 ¹⁾	-40 -50 ¹⁾	-40 -50 ¹⁾	-196	-19 -26 ¹⁾
		T1 ²⁾	-196	78	78	78	400	41	400	-40 -50 ¹⁾	-40 -50 ¹⁾	-40 -50 ¹⁾	-196	-19 -26 ¹⁾

1) Only in connection with Optional specification, ID Jx (Test, Certificate) = JN

2) Functional: Maximum permissible process temperature

FMR54

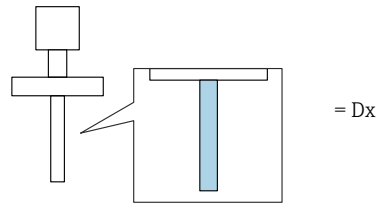

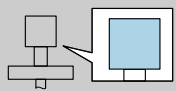
 = A	(2)		P1		P2		P3		P4		P5		P6	
			T _p	T _a	T _p	T _a	T _p	T _a	T _p	T _a	T _p	T _a	T _p	T _a
	B	T6	-40	43	43	43	85	34	85	-40	-40	-40	-	-
		T5	-40	56	56	56	100	47	100	-40	-40	-40	-	-
		T4	-40	56	56	56	135	39	135	-40	-40	-40	-	-
		T3 ¹⁾	-40	56	56	56	150	36	150	-40	-40	-40	-	-
	C	T6	-40	60	60	60	85	50	85	-40	-40	-40	-	-
		T5	-40	75	75	75	100	65	100	-40	-40	-40	-	-
		T4	-40	76	76	76	135	63	135	-40	-40	-40	-	-
		T3 ¹⁾	-40	76	76	76	150	59	150	-40	-40	-40	-	-

1) Functional: Maximum permissible process temperature

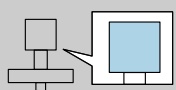
 = B	(2)		P1		P2		P3		P4		P5		P6	
			T _p	T _a	T _p	T _a	T _p	T _a	T _p	T _a	T _p	T _a	T _p	T _a
	B	T6	-40	51	51	51	85	45	85	-40	-40	-40	-	-
		T5	-40	66	66	66	100	60	100	-40	-40	-40	-	-
		T4	-40	75	75	75	135	64	135	-40	-40	-40	-	-
		T3 ¹⁾	-40	75	75	75	150	62	150	-40	-40	-40	-	-
	C	T6	-40	60	60	60	85	55	85	-40	-40	-40	-	-
		T5	-40	75	75	75	100	70	100	-40	-40	-40	-	-
		T4	-40	78	78	78	135	68	135	-40	-40	-40	-	-
		T3 ¹⁾	-40	78	78	78	150	65	150	-40	-40	-40	-	-

1) Functional: Maximum permissible process temperature

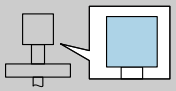
 = C	(2)	P1		P2		P3		P4		P5		P6		
		T _p	T _a	T _p	T _a	T _p	T _a	T _p	T _a	T _p	T _a	T _p	T _a	
	B	T6	-40	51	51	51	85	46	85	-40	-40	-40	-	-
		T5	-40	66	66	66	100	61	100	-40	-40	-40	-	-
		T4	-40	75	75	75	135	66	135	-40	-40	-40	-	-
		T3 ¹⁾	-40	75	75	75	150	64	150	-40	-40	-40	-	-
	C	T6	-40	60	60	60	85	56	85	-40	-40	-40	-	-
		T5	-40	75	75	75	100	71	100	-40	-40	-40	-	-
		T4	-40	78	78	78	135	70	135	-40	-40	-40	-	-
		T3 ¹⁾	-40	78	78	78	150	68	150	-40	-40	-40	-	-

1) Functional: Maximum permissible process temperature

FMR56

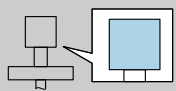
 = A	(2)		P1		P2		P3		P4		P5		P6	
			T _p	T _a	T _p	T _a	T _p	T _a	T _p	T _a	T _p	T _a	T _p	T _a
	B	T6	-40	43	43	43	80	38	80	-40	-40	-40	-	-
	C	T6	-40	60	60	60	80	55	80	-40	-40	-40	-	-

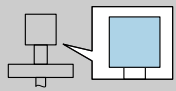
 = C	(2)		P1		P2		P3		P4		P5		P6	
			T _p	T _a	T _p	T _a	T _p	T _a	T _p	T _a	T _p	T _a	T _p	T _a
	B	T6	-40	51	51	51	80	49	80	-40	-40	-40	-	-
	C	T6	-40	60	60	60	80	58	80	-40	-40	-40	-	-

FMR57

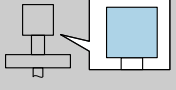
 = A	(2)	P1		P2		P3		P4		P5		P6		
		T _p	T _a	T _p	T _a	T _p	T _a	T _p	T _a	T _p	T _a	T _p	T _a	
	B	T6	-40	43	43	43	85	37	85	-40	-40	-40	-	-
		T5	-40	56	56	56	100	49	100	-40	-40	-40	-	-
		T4	-40	56	56	56	135	43	135	-40	-40	-40	-	-
		T3	-40	56	56	56	200	33	200	-40	-40	-40	-	-
	C	T6	-40	60	60	60	85	53	85	-40	-40	-40	-	-
		T5	-40	75	75	75	100	68	100	-40	-40	-40	-	-
		T4	-40	76	76	76	135	66	135	-40	-40	-40	-	-
		T3	-40	76	76	76	200	53	200	-40	-40	-40	-	-

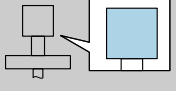
 = B	(2)	P1		P2		P3		P4		P5		P6		
		T _p	T _a	T _p	T _a	T _p	T _a	T _p	T _a	T _p	T _a	T _p	T _a	
	B	T6	-40	51	51	51	85	47	85	-40	-40	-40	-	-
		T5	-40	66	66	66	100	62	100	-40	-40	-40	-	-
		T4	-40	75	75	75	135	68	135	-40	-40	-40	-	-
		T3	-40	75	75	75	200	60	200	-40	-40	-40	-	-
	C	T6	-40	60	60	60	85	56	85	-40	-40	-40	-	-
		T5	-40	75	75	75	100	71	100	-40	-40	-40	-	-
		T4	-40	78	78	78	135	71	135	-40	-40	-40	-	-
		T3	-40	78	78	78	200	63	200	-40	-40	-40	-	-

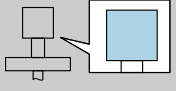
 = C	(2)	P1		P2		P3		P4		P5		P6		
		T _p	T _a	T _p	T _a	T _p	T _a	T _p	T _a	T _p	T _a	T _p	T _a	
	B	T6	-40	51	51	51	85	48	85	-40	-40	-40	-	-
		T5	-40	66	66	66	100	63	100	-40	-40	-40	-	-
		T4	-40	75	75	75	135	69	135	-40	-40	-40	-	-
		T3	-40	75	75	75	200	63	200	-40	-40	-40	-	-
	C	T6	-40	60	60	60	85	57	85	-40	-40	-40	-	-
		T5	-40	75	75	75	100	72	100	-40	-40	-40	-	-
		T4	-40	78	78	78	135	73	135	-40	-40	-40	-	-
		T3	-40	78	78	78	200	66	200	-40	-40	-40	-	-

FMR57

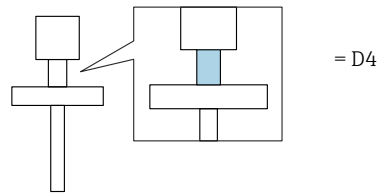

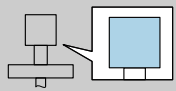
 = A	(2)	P1		P2		P3		P4		P5		P6		
		T _p	T _a	T _p	T _a	T _p	T _a	T _p	T _a	T _p	T _a	T _p	T _a	
	B	T6	-40	43	43	43	85	38	85	-40	-40	-40	-	-
		T5	-40	56	56	56	100	51	100	-40	-40	-40	-	-
		T4	-40	56	56	56	135	46	135	-40	-40	-40	-	-
		T3	-40	56	56	56	200	37	200	-40	-40	-40	-	-
	C	T6	-40	60	60	60	85	54	85	-40	-40	-40	-	-
		T5	-40	75	75	75	100	69	100	-40	-40	-40	-	-
		T4	-40	76	76	76	135	68	135	-40	-40	-40	-	-
		T3	-40	76	76	76	200	59	200	-40	-40	-40	-	-
		T2	-40	76	76	76	300	37	300	-40	-40	-40	-	-
		T1	-40	76	76	76	400	37	400	-40	-40	-40	-	-

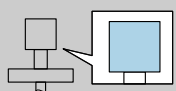
 = B	(2)	P1		P2		P3		P4		P5		P6		
		T _p	T _a	T _p	T _a	T _p	T _a	T _p	T _a	T _p	T _a	T _p	T _a	
	B	T6	-40	51	51	51	85	48	85	-40	-40	-40	-	-
		T5	-40	66	66	66	100	63	100	-40	-40	-40	-	-
		T4	-40	75	75	75	135	70	135	-40	-40	-40	-	-
		T3	-40	75	75	75	200	64	200	-40	-40	-40	-	-
		T2	-40	75	75	75	300	54	300	-40	-40	-40	-	-
		T1 ¹⁾	-40	75	75	75	400	45	400	-40	-40	-40	-	-
	C	T6	-40	60	60	60	85	57	85	-40	-40	-40	-	-
		T5	-40	75	75	75	100	72	100	-40	-40	-40	-	-
		T4	-40	78	78	78	135	73	135	-40	-40	-40	-	-
		T3	-40	78	78	78	200	67	200	-40	-40	-40	-	-
		T2	-40	78	78	78	300	58	300	-40	-40	-40	-	-
		T1 ¹⁾	-40	78	78	78	400	49	400	-40	-40	-40	-	-

1) Functional: Maximum permissible process temperature

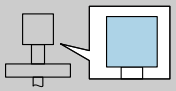
 = C	(2)	P1		P2		P3		P4		P5		P6		
		T _p	T _a	T _p	T _a	T _p	T _a	T _p	T _a	T _p	T _a	T _p	T _a	
	B	T6	-40	51	51	51	85	49	85	-40	-40	-40	-	-
		T5	-40	66	66	66	100	64	100	-40	-40	-40	-	-
		T4	-40	75	75	75	135	71	135	-40	-40	-40	-	-
		T3	-40	75	75	75	200	66	200	-40	-40	-40	-	-
		T2	-40	75	75	75	300	59	300	-40	-40	-40	-	-
		T1 ¹⁾	-40	75	75	75	400	52	400	-40	-40	-40	-	-
	C	T6	-40	60	60	60	85	58	85	-40	-40	-40	-	-
		T5	-40	75	75	75	100	73	100	-40	-40	-40	-	-
		T4	-40	78	78	78	135	74	135	-40	-40	-40	-	-
		T3	-40	78	78	78	200	69	200	-40	-40	-40	-	-
		T2	-40	78	78	78	300	62	300	-40	-40	-40	-	-
		T1 ¹⁾	-40	78	78	78	400	55	400	-40	-40	-40	-	-

1) Functional: Maximum permissible process temperature



www.addresses.endress.com
