

# Safety Instructions

## Cerabar M PMC51

4-20 mA HART, PROFIBUS PA,  
FOUNDATION Fieldbus

ATEX, IECEx: Ex ia IIIC Da/Db





# Cerabar M PMC51

4-20 mA HART, PROFIBUS PA, FOUNDATION Fieldbus

## Table of contents

About this document .....	4
Associated documentation .....	4
Supplementary documentation .....	4
Manufacturer's certificates .....	4
Manufacturer address .....	5
Other standards .....	5
Extended order code .....	5
Safety instructions: General .....	7
Safety instructions: Special conditions .....	7
Safety instructions: Installation .....	8
Temperature tables .....	8
Connection data .....	9

## About this document



This document has been translated into several languages. Legally determined is solely the English source text.

The document translated into EU languages is available:

- In the download area of the Endress+Hauser website:  
[www.endress.com](http://www.endress.com) -> Downloads -> Manuals and Datasheets ->  
 Type: Ex Safety Instruction (XA) -> Text Search: ...
- In the Device Viewer: [www.endress.com](http://www.endress.com) -> Product tools ->  
 Access device specific information -> Check device features



If not yet available, the document can be ordered.

## Associated documentation

This document is an integral part of the following Operating Instructions:

HART  
 BA00382P/00  
 PROFIBUS PA  
 BA00383P/00  
 FOUNDATION Fieldbus  
 BA00384P/00

## Supplementary documentation

Explosion-protection brochure: CP00021Z/11

The Explosion-protection brochure is available:

- In the download area of the Endress+Hauser website:  
[www.endress.com](http://www.endress.com) -> Downloads -> Brochures and Catalogs ->  
 Text Search: CP00021Z
- On the CD for devices with CD-based documentation

## Manufacturer's certificates

### EU Declaration of Conformity

Declaration Number:  
 EG09008

The EU Declaration of Conformity is available:

In the download area of the Endress+Hauser website:  
[www.endress.com](http://www.endress.com) -> Downloads -> Declaration ->  
 Type: EU Declaration -> Product Code: ...

### EU type-examination certificate

Certificate number:  
 KEMA 09ATEX0048 X

List of applied standards: See EU Declaration of Conformity.

### IEC Declaration of Conformity

Certificate number:  
IECEX KEM 09.0016X

Affixing the certificate number certifies conformity with the following standards (depending on the device version):

- IEC 60079-0 : 2017
- IEC 60079-11 : 2011

### Manufacturer address

Endress+Hauser SE+Co. KG  
Hauptstraße 1  
79689 Maulburg, Germany  
Address of the manufacturing plant: See nameplate.

### Other standards

Among other things, the following standards shall be observed in their current version for proper installation:

- IEC/EN 60079-14: "Explosive atmospheres - Part 14: Electrical installations design, selection and erection"
- EN 1127-1: "Explosive atmospheres - Explosion prevention and protection - Part 1: Basic concepts and methodology"

### Extended order code

The extended order code is indicated on the nameplate, which is affixed to the device in such a way that it is clearly visible. Additional information about the nameplate is provided in the associated Operating Instructions.

### Structure of the extended order code

PMC51	-	*****	+	A*B*C*D*E*F*G*..
<i>(Device type)</i>		<i>(Basic specifications)</i>		<i>(Optional specifications)</i>

\* = Placeholder

At this position, an option (number or letter) selected from the specification is displayed instead of the placeholders.

### *Basic specifications*

The features that are absolutely essential for the device (mandatory features) are specified in the basic specifications. The number of positions depends on the number of features available. The selected option of a feature can consist of several positions.

### *Optional specifications*

The optional specifications describe additional features for the device (optional features). The number of positions depends on the number of features available. The features have a 2-digit structure to aid identification (e.g. JA). The first digit (ID) stands for the feature group and consists of a number or a letter (e.g. J = Test, Certificate). The second digit constitutes the value that stands for the feature within the group (e.g. A = 3.1 material (wetted parts), inspection certificate).

More detailed information about the device is provided in the following tables. These tables describe the individual positions and IDs in the extended order code which are relevant to hazardous locations.

### **Extended order code: Cerabar M**



The following specifications reproduce an extract from the product structure and are used to assign:

- This documentation to the device (using the extended order code on the nameplate).
- The device options cited in the document.

### *Device type*

PMC51

### *Basic specifications*

Position 1, 2 (Approval)		
Selected option		Description
PMC51	BF	ATEX II 1/2 D Ex ia IIIc T <sub>200</sub> 135°C Da/Db
	IF	IECEX Ex ia IIIc T <sub>200</sub> 135°C Da/Db

Position 3 (Output)		
Selected option		Description
PMC51	2	4-20 mA HART
	3	PROFIBUS PA
	4	FOUNDATION Fieldbus

### *Optional specifications*

No options specific to hazardous locations are available.

#### **Safety instructions: General**

- The device is intended to be used in explosive atmospheres as defined in the scope of IEC 60079-0 or equivalent national standards. If no potentially explosive atmospheres are present or if additional protective measures have been taken: The device may be operated according to the manufacturer's specifications.
- Staff must meet the following conditions for mounting, electrical installation, commissioning and maintenance of the device:
  - Be suitably qualified for their role and the tasks they perform
  - Be trained in explosion protection
  - Be familiar with national regulations
- Comply with the installation and safety instructions in the Operating Instructions.
- Install the device according to the manufacturer's instructions and national regulations.
- Only use the device in media to which the wetted materials have sufficient durability.
- Avoid electrostatic charging:
  - Of plastic surfaces (e.g. enclosure, sensor element, special varnishing, attached additional plates, ..)
  - Of isolated capacities (e.g. isolated metallic plates)

#### **Safety instructions: Special conditions**

- In the case of process connections made of polymeric material or with polymeric coatings, avoid electrostatic charging of the plastic surfaces.
- In the event of additional or alternative special varnishing on the enclosure or other metal parts:
  - Observe the danger of electrostatic charging and discharge.
  - Do not rub surfaces with a dry cloth.

## Safety instructions: Installation

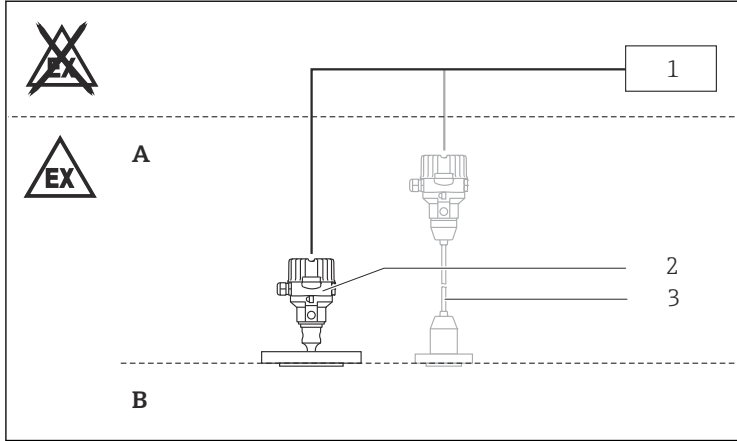

A0024001

- A *Electronic; Zone 21*  
 B *Process; Zone 20*  
 1 *Certified associated apparatus*  
 2 *PMC51*  
 3 *Option: Separate enclosure*

- Do not open in a potentially explosive dust atmosphere.
- Seal the cable entry or piping tight (see protection type of enclosure in the "Temperature tables" chapter).
- Connect the device using suitable cable and wire entries of protection type "Equipment dust ignition protection by enclosure (Ex t)" or "Increased safety (Ex e)" (ingress protection of at least IP65). Lay connecting cable and secure.

## Temperature tables

- i
  - The specified surface temperature takes into account all direct heat influences from process heat and self-heating at the enclosure.
  - Surface temperatures at the process side maybe higher and must be considered by the user (e.g. at high temperature process connections).
  - The T-marking is based on the process temperature of the compact designs.
  - The specified ambient and process temperature ranges exclusively refer to the explosion protection and must not be exceeded. Operationally permitted ambient temperature ranges can be restricted depending on the version: See Operating Instructions.
  - Do not exceed the max. ambient temperature at the enclosure.
  - The process temperatures refer to the temperature at the separation membrane.



Maximum surface temperature	Process temperature range	Ambient temperature range
T135 °C	$-40\text{ °C} \leq T_p \leq +80\text{ °C}$	$-40\text{ °C} \leq T_a \leq +55\text{ °C}$
	$-40\text{ °C} \leq T_p \leq +100\text{ °C}$	$-40\text{ °C} \leq T_a \leq +50\text{ °C}$
	$-40\text{ °C} \leq T_p \leq +125\text{ °C}$	$-40\text{ °C} \leq T_a \leq +45\text{ °C}$

Specific conditions of use:

The surface temperature is

- for equipment protection level (EPL) Da:  $T_{200}$  135 °C (with 200 mm dust deposit)
- and equipment protection level (EPL) Db:  $T_L$  135 °C (with dust accumulation  $T_L$ )



$T_L$  marking:

The assigned surface temperature without dust layer is the same.

### Connection data

Basic specification, Position 3 = 2

Power supply
$U_i \leq 30\text{ V}_{DC}$ $I_i \leq 300\text{ mA}$ $P_i \leq 1\text{ W}$ $C_i \leq 10\text{ nF}$ $L_i = 0$

Basic specification, Position 3 = 3, 4

Power supply	
FISCO	Entity
$U_i \leq 17.5\text{ V}_{DC}$ $I_i \leq 500\text{ mA}$ $P_i \leq 5.5\text{ W}$ $C_i \leq 5\text{ nF}$ $L_i \leq 10\text{ }\mu\text{H}$	$U_i \leq 24\text{ V}_{DC}$ $I_i \leq 250\text{ mA}$ $P_i \leq 1.2\text{ W}$ $C_i \leq 5\text{ nF}$ $L_i \leq 10\text{ }\mu\text{H}$

## Cable entry: Connection compartment

Thread	Clamping range	Material	Sealing insert	O-ring
M20x1,5	$\varnothing$ 8 to 10.5 mm <sup>1)</sup> $\varnothing$ 6.5 to 13 mm <sup>2)</sup>	Ms, nickel-plated	Silicone	EPDM ( $\varnothing$ 17x2)

- 1) Standard  
 2) Separate clamping inserts available

- 
  - The tightening torque refers to cable glands installed by the manufacturer:
    - Recommended: 3.5 Nm
    - Maximum: 10 Nm
  - This value may be different depending on the type of cable. However, the maximum value must not be exceeded.
- Only suitable for fixed installation. The operator must pay attention to a suitable strain relief of the cable.
- To maintain the ingress protection of the housing: Install the housing cover, cable glands and blind plugs correctly.





71538614

[www.addresses.endress.com](http://www.addresses.endress.com)

---