

Safety Instructions

Soliphant M

FTM50, FTM51, FTM52

II 3 G Ex ec IIC Gc

II 3 G Ex ec nC IIC Gc

II 3 G Ex ic IIC Gc

II 3 D Ex tc IIIC Dc

II 3 D Ex ic IIIC Dc



Soliphant M FTM50, FTM51, FTM52

Table of contents

About this document	4
Associated documentation	4
Supplementary documentation	4
Manufacturer's certificates	4
Manufacturer address	5
Other standards	5
Extended order code	5
Safety instructions: General	7
Safety instructions: Special conditions	8
Safety instructions: Installation	8
Temperature tables	13
Connection data	23

About this document



This document has been translated into several languages. Legally determined is solely the English source text.

The document translated into EU languages is available:

- In the download area of the Endress+Hauser website:
www.endress.com -> Downloads -> Manuals and Datasheets -> Type: Ex Safety Instruction (XA) -> Text Search: ...
- In the Device Viewer: www.endress.com -> Product tools -> Access device specific information -> Check device features



If not yet available, the document can be ordered.

Associated documentation

This document is an integral part of the following Operating Instructions:

- KA00229F/00 (FTM50, FTM51)
- KA00230F/00 (FTM52)
- TI00392F/00 (FTM50, FTM51, FTM52)

Supplementary documentation

Explosion-protection brochure: CP00021Z/11

The Explosion-protection brochure is available:

- In the download area of the Endress+Hauser website:
www.endress.com -> Downloads -> Brochures and Catalogs -> Text Search: CP00021Z
- On the CD for devices with CD-based documentation

Manufacturer's certificates

EU Declaration of Conformity

Declaration Number:

EU_00930

The EU Declaration of Conformity is available:

In the download area of the Endress+Hauser website:
www.endress.com -> Downloads -> Declaration -> Type: EU Declaration -> Product Code: ...

EU type-examination certificate

Certificate number:

EU 00930 X

List of applied standards: See EU Declaration of Conformity.

Manufacturer address	Endress+Hauser SE+Co. KG Hauptstraße 1 79689 Maulburg, Germany Address of the manufacturing plant: See nameplate.
Other standards	Among other things, the following standards shall be observed in their current version for proper installation: <ul style="list-style-type: none"> ■ IEC/EN 60079-14: "Explosive atmospheres - Part 14: Electrical installations design, selection and erection" ■ EN 1127-1: "Explosive atmospheres - Explosion prevention and protection - Part 1: Basic concepts and methodology"
Extended order code	The extended order code is indicated on the nameplate, which is affixed to the device in such a way that it is clearly visible. Additional information about the nameplate is provided in the associated Operating Instructions.

Structure of the extended order code

FTM5x	-	*****	+	A*B*C*D*E*F*G*..
<i>(Device type)</i>		<i>(Basic specifications)</i>		<i>(Optional specifications)</i>

* = Placeholder

At this position, an option (number or letter) selected from the specification is displayed instead of the placeholders.

Basic specifications

The features that are absolutely essential for the device (mandatory features) are specified in the basic specifications. The number of positions depends on the number of features available. The selected option of a feature can consist of several positions.

Optional specifications

The optional specifications describe additional features for the device (optional features). The number of positions depends on the number of features available. The features have a 2-digit structure to aid identification (e.g. JA). The first digit (ID) stands for the feature group and consists of a number or a letter (e.g. J = Test, Certificate). The second digit constitutes the value that stands for the feature within the group (e.g. A = 3.1 material (wetted parts), inspection certificate).

More detailed information about the device is provided in the following tables. These tables describe the individual positions and IDs in the extended order code which are relevant to hazardous locations.

Extended order code: Soliphant M



The following specifications reproduce an extract from the product structure and are used to assign:

- This documentation to the device (using the extended order code on the nameplate).
- The device options cited in the document.

Device type

FTM50, FTM51, FTM52

Basic specifications

Position 1 (Approval)		
Selected option		Description
FTM5x	3 ¹⁾	ATEX II 3 G Ex ec IIC T6 Gc ATEX II 3 G Ex ec nC IIC T6 Gc ATEX II 3 G Ex ic IIC T6 Gc ATEX II 3 D Ex tc IIIC T93°C Dc ATEX II 3 D Ex ic IIIC T75°C Dc

- 1) Observe the specifications in the "Installation" chapter!

Position 6 (Electronics, Output)		
Selected option		Description
FTM5x	1	FEM51; 2-wire 19-253VAC
	2	FEM52; 3-wire PNP 10-55VDC
	4	FEM54; relay DPDT, 19-253VAC/55VDC
	5	FEM55; 8/16mA, 11-35VDC
	7	FEM57; 2-wire PFM
	8	FEM58; NAMUR + test button (H-L signal)

Position 7 (Type of Probe)		
Selected option		Description
FTM5x	A	Compact
	D, E	Cable > separate enclosure
	G, H	Cable, armoured > separate enclosure

Position 8 (Housing)		
Selected option		Description
FTM5x	H	T13 Alu IP66/68 NEMA Type 4X/6P Encl., separate conn. compartment
	3	F17 Alu IP66/67 NEMA Type 4X Encl.
	5	F13 Alu IP66/68 NEMA Type 4X/6P Encl.
	6	F27 316L IP67/68 NEMA Type 4X/6P Encl.
	7	F15 316L hygiene IP66/67

Position 11 (Additional Option 2)		
Selected option		Description
FTM50 FTM51	A	Not selected
	C	EN10204-3.1 material (wetted parts), inspection certificate
	D, E	Temp. separator $\leq 150^{\circ}\text{C}$
	F, H	High temperature $\leq 280^{\circ}\text{C}$
	J, K	High temperature $\leq 230^{\circ}\text{C}$
	Y	Special version: High temperature $\leq 300^{\circ}\text{C}$
FTM52	A	Not selected

Optional specifications

No options specific to hazardous locations are available.

Safety instructions: General

- The device is intended to be used in explosive atmospheres as defined in the scope of EN IEC 60079-0 or equivalent national standards. If no potentially explosive atmospheres are present or if additional protective measures have been taken: The device may be operated according to the manufacturer's specifications.
- Staff must meet the following conditions for mounting, electrical installation, commissioning and maintenance of the device:
 - Be suitably qualified for their role and the tasks they perform
 - Be trained in explosion protection
 - Be familiar with national regulations
- Install the device according to the manufacturer's instructions and national regulations.
- Do not operate the device outside the specified electrical, thermal and mechanical parameters.
- Only use the device in media to which the wetted materials have sufficient durability.

- Avoid electrostatic charging:
 - Of plastic surfaces (e.g. enclosure, sensor element, special varnishing, attached additional plates, ..)
 - Of isolated capacities (e.g. isolated metallic plates)
- Refer to the temperature tables for the relationship between the permitted ambient temperature for the sensor and/or transmitter, depending on the range of application and the temperature class.
- Modifications to the device can affect the explosion protection and must be carried out by staff authorized to perform such work by Endress+Hauser.

Safety instructions:
Special conditions

- To avoid electrostatic charging: Do not rub surfaces with a dry cloth.
- In the event of additional or alternative special varnishing on the enclosure or other metal parts or for adhesive plates:
 - Observe the danger of electrostatic charging and discharge.
 - Do not install in the vicinity of processes (≤ 0.5 m) generating strong electrostatic charges.

Basic specification, Position 6 = 1, 4

- In a condensing atmosphere: The device must not be serviced or installed.
- The device must be externally protected against transient overvoltage up to 140 % of the maximum voltage.

Safety instructions:
Installation

Basic specification, Position 1 = 3 in connection with Position 7 = A

FTM50	ATEX II 3 G Ex ec IIC T6...T3 Gc ^{1) 2)}
FTM51	ATEX II 3 G Ex ec IIC T6...T2 Gc ^{1) 3)}
	ATEX II 3 G Ex ec nC IIC T6...T3 Gc ^{2) 4)}
	ATEX II 3 G Ex ec nC IIC T6...T2 Gc ^{3) 4)}
	ATEX II 3 G Ex ic IIC T6...T3 Gc ^{2) 5)}
	ATEX II 3 G Ex ic IIC T6...T2 Gc ^{3) 5)}
	ATEX II 3 D Ex tc IIIC T93°C Dc
	ATEX II 3 D Ex ic IIIC T75°C Dc ⁵⁾

- 1) Only in connection with Position 6 = 1, 2, 5, 7, 8
- 2) Only in connection with Position 11 = A, C, D, E
- 3) Only in connection with Position 11 = F, H, J, K, Y
- 4) Only in connection with Position 6 = 4
- 5) Only in connection with Position 6 = 5, 7, 8

Basic specification, Position 1 = 3 in connection with Position 7 = D, E, G, H

FTM50	ATEX II 3 G Ex ec [ic Gc] IIC T6...T3 Gc ^{1) 2)}
FTM51	ATEX II 3 G Ex ec [ic Gc] IIC T6...T2 Gc ^{1) 3)}
	ATEX II 3 G Ex ec nC [ic Gc] IIC T6...T3 Gc ^{2) 4)}
	ATEX II 3 G Ex ec nC [ic Gc] IIC T6...T2 Gc ^{2) 4)}
	ATEX II 3 G Ex ic [ic Gc] IIC T6...T3 Gc ^{2) 5)}
	ATEX II 3 G Ex ic [ic Gc] IIC T6...T2 Gc ^{3) 5)}
	ATEX II 3 D Ex tc [ic Dc] IIIC T93°C Dc
	ATEX II 3 D Ex ic [ic Dc] IIIC T75°C Dc ⁵⁾

- 1) Only in connection with Position 6 = 1, 2, 5, 7, 8
- 2) Only in connection with Position 11 = A, C, D, E
- 3) Only in connection with Position 11 = F, H, J, K, Y
- 4) Only in connection with Position 6 = 4
- 5) Only in connection with Position 6 = 5, 7, 8

Basic specification, Position 1 = 3

FTM52	ATEX II 3 G Ex ec [ic Gc] IIC T6 Gc ¹⁾
	ATEX II 3 G Ex ec nC [ic Gc] IIC T6 Gc ²⁾
	ATEX II 3 G Ex ic [ic Gc] IIC T6 Gc ³⁾
	ATEX II 3 D Ex tc [ic Dc] IIIC T93°C Dc
	ATEX II 3 D Ex ic [ic Dc] IIIC T75°C Dc ³⁾

- 1) Only in connection with Position 6 = 1, 2, 5, 7, 8
- 2) Only in connection with Position 6 = 4
- 3) Only in connection with Position 6 = 5, 7, 8

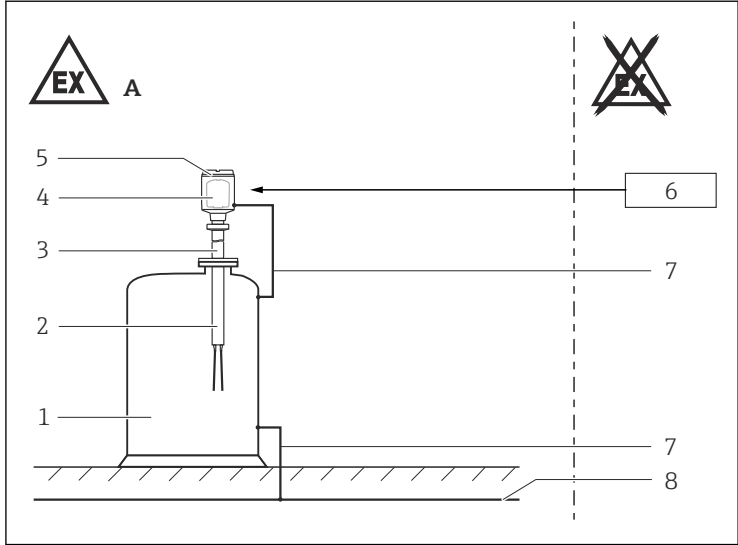

A0027391

 1

- A Zone 2 or Zone 22
- 1 Tank; Hazardous area Zone 2 or Zone 22
- 2 Version
- 3 Temperature separator (optional at 150 °C)
- 4 Electronic insert; Electronic compartment
- 5 Enclosure
- 6 Power supply
- 7 Potential equalization line
- 8 Potential equalization



Electronic compartment: Depending on the internal electronics insert and applied installation.

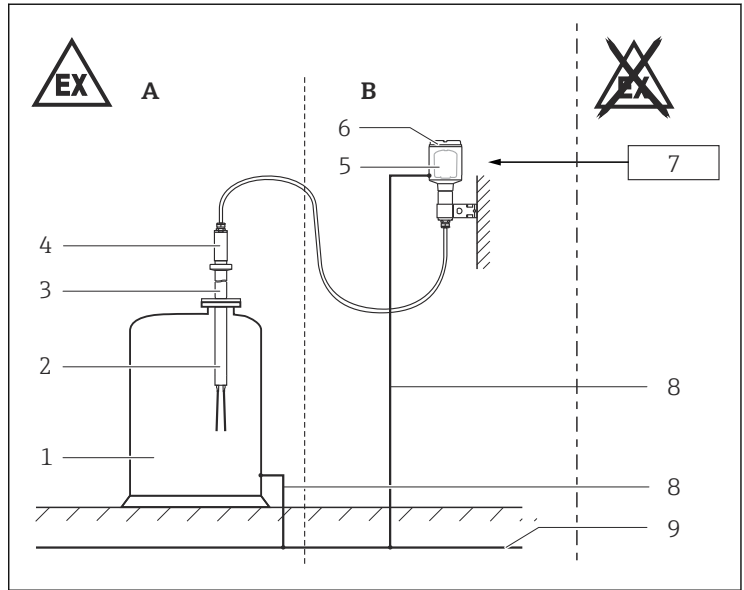

A0027409

 2

- A Zone 2 or Zone 22
 B Zone 2 or Zone 22
 1 Tank; Hazardous area Zone 2 or Zone 22
 2 Version
 3 Temperature spacer (optional at 150 °C)
 4 Sensor enclosure
 5 Electronic insert; Electronic compartment
 6 Electronics enclosure
 7 Power supply
 8 Potential equalization line
 9 Potential equalization



Electronic compartment: Depending on the internal electronics insert and applied installation.

- After mounting and connecting the sensor, ingress protection of the enclosure must be at least IP65.
- Perform the following to achieve the degree of protection IP66/67 or IP66/68:
 - Screw the cover tight.
 - Mount the cable entry correctly.
- Use a process connection seal that meets the materials compatibility and temperature requirements.
- When connecting the cables, ensure there is adequate strain relief at place of installation.

- Protect the connecting cable between the separate enclosure and the level sensor from tension and friction (e.g. due to electrostatic charge from medium flow).
- Observe the maximum process conditions according to the manufacturer's Operating Instructions.
- At high medium temperatures, note flange pressure load capacity as a factor of temperature.
- Install the device to exclude any mechanical damage or friction during the application. Pay particular attention to flow conditions and tank fittings.
- Support extension tube of the device if a dynamic load is expected.
- Only use certified cable entries suitable for the application. Observe national regulations and standards.
- When operating the transmitter enclosure at an ambient temperature under $-20\text{ }^{\circ}\text{C}$, use appropriate cables and cable entries permitted for this application.
- Seal unused entry glands with approved sealing plugs that correspond to the type of protection. The plastic transport sealing plug does not meet this requirement and must therefore be replaced during installation.
- Supplied cable glands and metallic sealing plugs comply with the requirements of type of protection marked on the nameplate.
- Before operation:
 - Screw in the cover all the way.
 - Tighten the securing clamp on the cover.
- In potentially explosive atmospheres:
 - Do not disconnect the electrical connection of the power supply circuit when energized.
 - Do not open the connection compartment cover and the electronics compartment cover when energized.

Basic specification, Position 6 = 1, 2, 5, 7, 8

Continuous service temperature of the connecting cable:

$T_{a,\min}$ to $T_{a,\max}$ application +10 K.

Basic specification, Position 6 = 4

Continuous service temperature of the connecting cable:

$T_{a,\min}$ to $T_{a,\max}$ application +40 K.

Zone 22

Maximum heating of the device surface: $\leq 23\text{ K}$.

Accessory high pressure sliding sleeve

The high pressure sliding sleeve can be used for a continuous setting of the switch point and is suited for zone separation if mounted properly (see Operating Instructions).

Potential equalization

Integrate the device into the local potential equalization.

Temperature tables



Basic specification, Position 8 = 3, 7: T_a restriction to -40 °C

Description notes



Unless otherwise indicated, the positions always refer to the basic specification.

Compact version

Electronic compartment Ex tc

Position 7 = A

II 3 D Ex tc IIIC T93°C Dc

Device type FTM50, FTM51

Position 11	Process temperature T_p (process)	Maximum surface temperature		Ambient temperature T_a (ambient)
	Fork	Fork Zone 22	Enclosure Zone 22	Enclosure
A, C, D, E	-50 to +150 °C	$T_p + 10\text{ K}$	$T_a + 23\text{ K}$	-50 to +60 °C
F, H	-50 to +280 °C			
J, K	-50 to +230 °C			

II 3 D Ex tc [ic Dc] IIIC T93°C Dc

Device type FTM52

Position 11	Process temperature T_p (process)	Maximum surface temperature		Ambient temperature T_a (ambient)
	Fork	Fork Zone 22	Enclosure Zone 22	Enclosure
A	-40 to +80 °C	$T_p + 5\text{ K}$	$T_a + 23\text{ K}$	-50 to +60 °C

Device type FTM50, FTM51

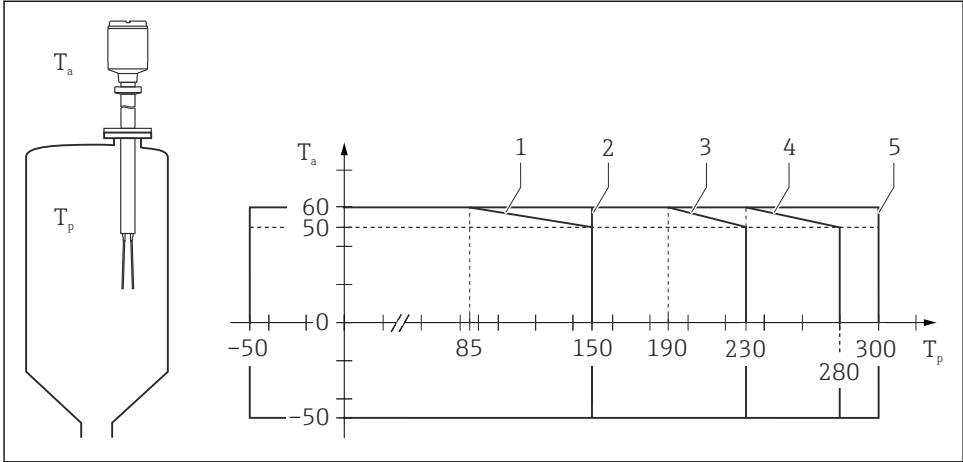

A0027393

3

 T_a Ambient temperature in °C T_p Process temperature in °C

1 Position 11 = A, C, D, E, without temperature separator

2 Position 11 = A, C, D, E, with temperature separator

3 Position 11 = J, K, with temperature separator inside the insulation

4 Position 11 = F, H, with temperature separator inside the insulation

5 Position 11 = Y, with temperature separator outside the insulation

Device type FTM52

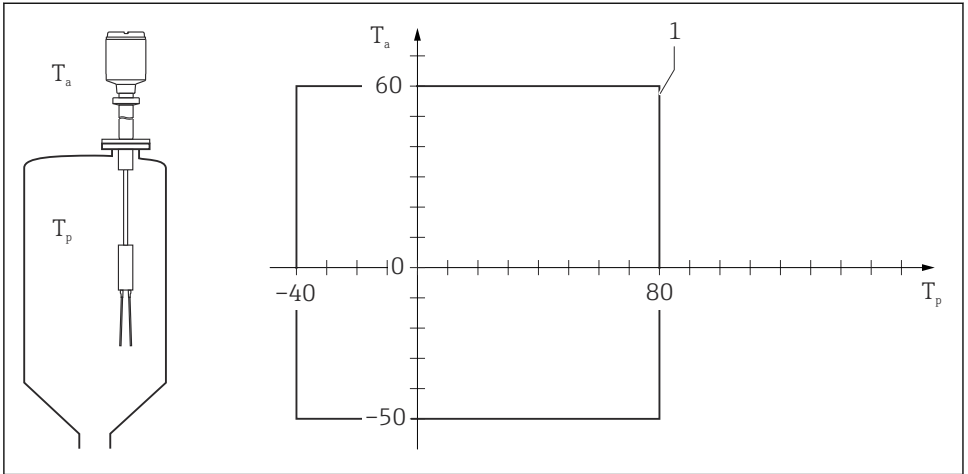

A0027410

4

 T_a Ambient temperature in °C T_p Process temperature in °C

1 Position 11 = A

Version with separate enclosure*Position 7 = D, E, G, H (Sensor)*

II 3 D Ex ic IIIC Txx°C +5 K Dc

Device type FTM50, FTM51

<i>Position 11</i>	Process temperature T_p (process) Fork	Maximum surface temperature		Ambient temperature T_a (ambient)
		Fork Zone 22	Sensor enclosure Zone 22	Sensor enclosure
A, C, D, E	-50 to +150 °C	$T_p +5 K$	$T_a +5 K$	-50 to +120 °C
F, H	-50 to +280 °C			
J, K	-50 to +230 °C			

Device type FTM52

<i>Position 11</i>	Process temperature T_p (process) Fork	Maximum surface temperature		Ambient temperature T_a (ambient)
		Fork Zone 22	Sensor enclosure Zone 22	Sensor enclosure
A	-40 to +80 °C	$T_p +5 K$	$T_a +5 K$	-50 to +80 °C

Position 7 = D, E, G, H (Enclosure)

II 3 D Ex tc [ic Dc] IIIC T93°C Dc

Device type FTM50, FTM51, FTM52

Maximum surface temperature Electronics enclosure Zone 22	Ambient temperature T_a (ambient) Electronics enclosure
$T_p +23 K$	-50 to +60 °C

Device type FTM50, FTM51

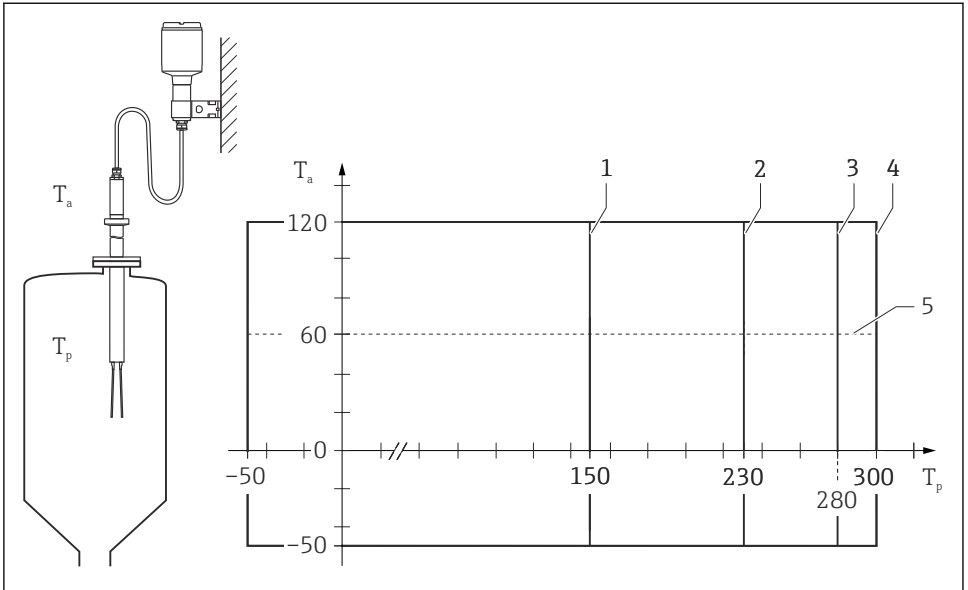

A0027396

5

T_a Ambient temperature in °C

T_p Process temperature in °C

1 Position 11 = A, C, D, E

2 Position 11 = J, K, with temperature separator

3 Position 11 = F, H, with temperature separator

4 Position 11 = Y, with temperature separator

5 T_a at enclosure: Restriction to 60 °C

Device type FTM52

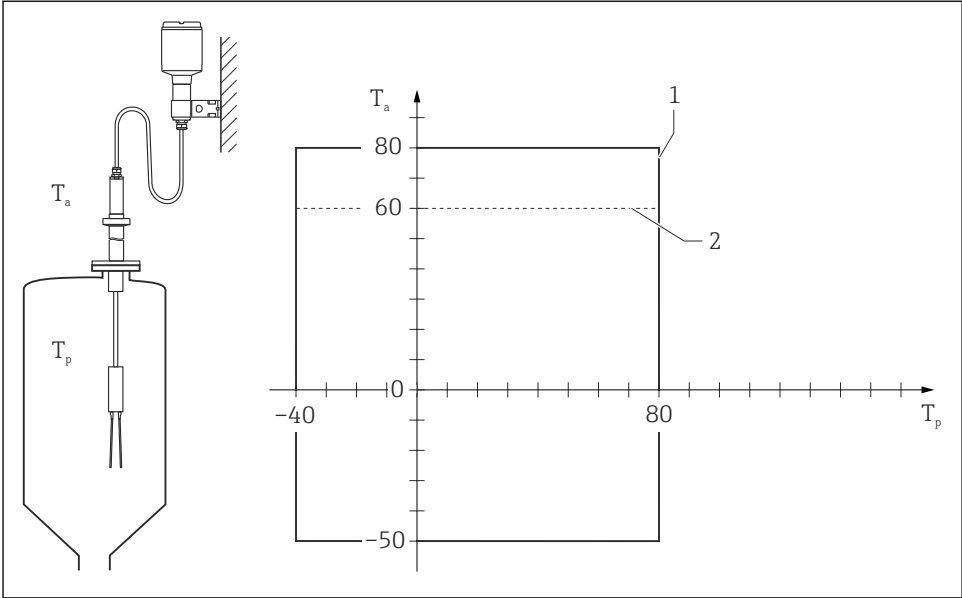

A0027411

6

- T_a Ambient temperature in °C
- T_p Process temperature in °C
- 1 Position 11 = A
- 2 T_a at enclosure: Restriction to 60 °C

Compact version**Electronic compartment Ex ec, Ex ec nC, Ex ic***Position 7 = A**Device type FTM50, FTM51*

- II 3 G Ex ec IIC T6...T2 Gc
- II 3 G Ex ec nC IIC T6...T2 Gc
- II 3 G Ex ic IIC T6...T2 Gc

Device type FTM52

- II 3 G Ex ec [ic Gc] IIC T6...T2 Gc
- II 3 G Ex ec nC [ic Gc] IIC T6...T2 Gc
- II 3 G Ex ic [ic Gc] IIC T6...T2 Gc

Device type FTM50, FTM51, FTM52

Type Version	Temperature class	Process temperature T _p (process): sensor	Ambient temperature T _a (ambient): electronics
FTM50, FTM51 150 °C, 230 °C, 280 °C	T6	-50 to +85 °C	<i>Position 6 = 1, 2, 5, 7, 8</i> -50 to +60 °C
FTM52 80 °C	T6	-40 to +80 °C	<i>Position 6 = 4</i> -50 to +35 °C
FTM50, FTM51 150 °C, 230 °C, 280 °C	T5	-50 to +100 °C	<i>Position 6 = 1, 2, 5, 7, 8</i> -50 to +70 °C <i>Position 6 = 4</i> -50 to +55 °C
FTM50, FTM51 150 °C, 230 °C, 280 °C	T4	-50 to +135 °C	-50 to +60 °C
FTM50, FTM51 150 °C 230 °C, 280 °C	T3 T3	-50 to +150 °C -50 to +200 °C	
FTM50, FTM51 230 °C, 280 °C	T2	-50 to +230 °C/ +280 °C	

Device type FTM50, FTM51, FTM52

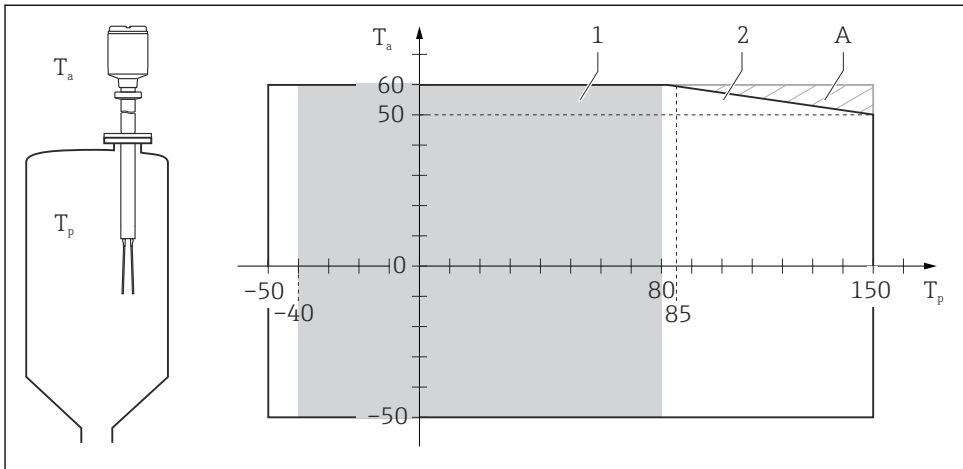

A0027412

7

 T_a Ambient temperature in °C T_p Process temperature in °C

A Additional temperature range for sensors with temperature separator

1 Device type FTM52

2 Device type FTM50, FTM51

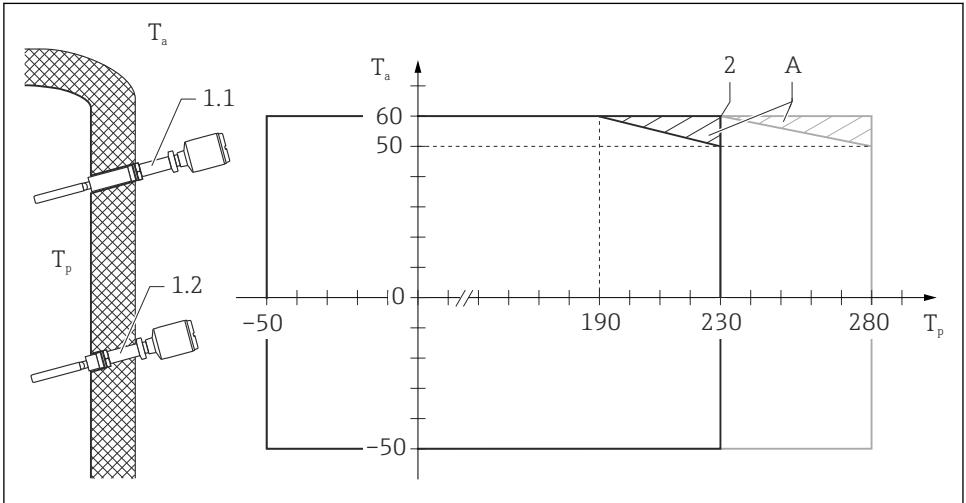
High-temperature version*Device type FTM50, FTM51*

A0027413

 8
 T_a Ambient temperature in °C T_p Process temperature in °C

A Additionally utilizable temperature range when using the temperature spacer outside the insulation

1 Temperature separator:

1.1 insulated

1.2 free-standing

2 Antistick coating possible up to max. 230 °C

Version with separate enclosure

Device type FTM50, FTM51, FTM52

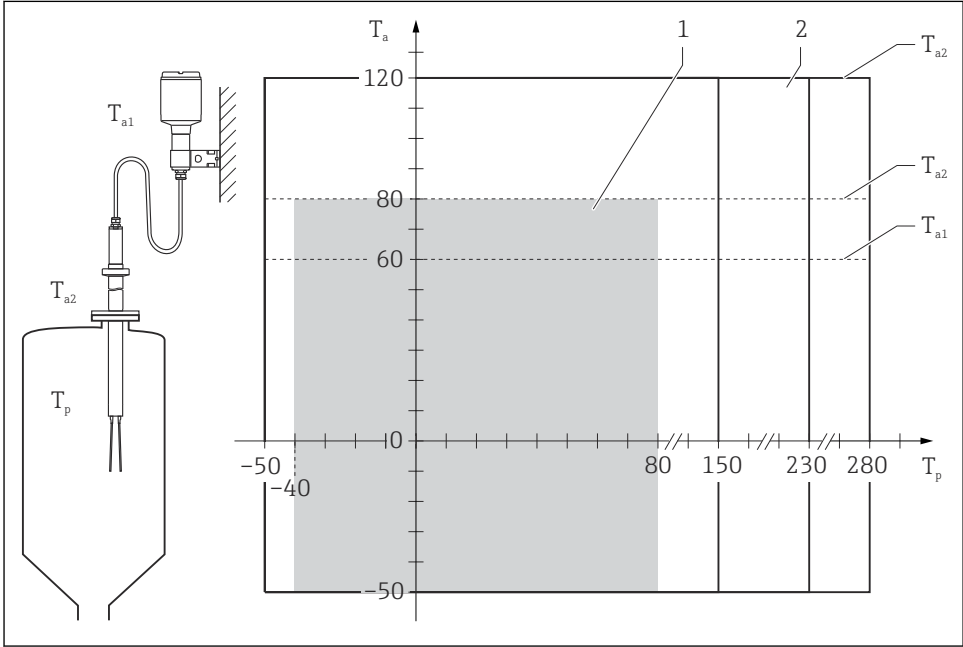

A0027414

9

T_a Ambient temperature in °C

T_p Process temperature in °C

1 Device type FTM52

2 Device type FTM50, FTM51

Connection data Electronic compartment Ex ec, Ex ec nC, Ex tc

Basic specification, Position 6	Power supply	Output
1	19 to 253 V _{AC} , 50/60 Hz, max. 1.0 W U _m = 253 V _{AC}	max. 350 mA
2	10 to 55 V _{DC} , max. 0.86 W U _m = 253 V _{AC}	PNP transistor, max. 350 mA
4	19 to 55 V _{DC} , max. 1.5 W or 19 to 253 V _{AC} , 50/60 Hz, max. 1.5 W U _m = 253 V _{AC}	2 potential free change-over contacts, 253 V _{AC} , 4 A; 1500 VA / cos φ = 1 750 VA / cos φ > 0.7 30 V _{DC} , 4 A; 125 V _{DC} , 0.2 A
5	11 to 35 V _{DC} , 8/16 mA, max. 0.6 W U _m = 253 V _{AC}	< 3.6 mA / 8 mA / 16 mA
7	9.5 to 12.5 V _{DC} , max. 0.15 W U _m = 16.7 V	PFM
8	8.2 V _{DC} ±20 %, 0.4 to 1 mA / 2.2 to 4 mA U _m = 18 V	NAMUR

Electronic compartment Ex ic

Basic specification, Position 6	Power supply
5	U _i = 35 V, I _i = 100 mA, P _i = 1 W L _i /C _i = 0
7	U _i = 16.7 V, I _i = 150 mA, P _i = 1 W L _i /C _i = 0
8	U _i = 18 V, I _i = 52 mA, P _i = 170 mW L _i /C _i = 0



71549697

www.addresses.endress.com
