

Safety Instructions

Cerabar S

PMC71, PMP71, PMP75

4-20 mA HART, PROFIBUS PA,
FOUNDATION Fieldbus

II 1 G Ex ia IIC Ga

II 1 D Ex ia IIC Da



Cerabar S PMC71, PMP71, PMP75

4-20 mA HART, PROFIBUS PA, FOUNDATION Fieldbus

Table of contents

About this document	4
Associated documentation	4
Supplementary documentation	4
Manufacturer's certificates	4
Manufacturer address	5
Other standards	5
Extended order code	5
Safety instructions: General	9
Safety instructions: Special conditions	9
Safety instructions: Installation	10
Temperature tables	11
Connection data	11

About this document



This document has been translated into several languages. Legally determined is solely the English source text.

The document translated into EU languages is available:

- In the download area of the Endress+Hauser website:
www.endress.com -> Downloads -> Manuals and Datasheets -> Type: Ex Safety Instruction (XA) -> Text Search: ...
- In the Device Viewer: www.endress.com -> Product tools -> Access device specific information -> Check device features



If not yet available, the document can be ordered.

Associated documentation

This document is an integral part of the following Operating Instructions:

HART

- BA00271P/00
- BA00274P/00

PROFIBUS PA

- BA00295P/00
- BA00296P/00

FOUNDATION Fieldbus

- BA00302P/00
- BA00303P/00

Supplementary documentation

Explosion-protection brochure: CP00021Z/11

The Explosion-protection brochure is available:

- In the download area of the Endress+Hauser website:
www.endress.com -> Downloads -> Brochures and Catalogs -> Text Search: CP00021Z
- On the CD for devices with CD-based documentation

Manufacturer's certificates

EU Declaration of Conformity

Declaration Number:

EG_04010

The EU Declaration of Conformity is available:

In the download area of the Endress+Hauser website:
www.endress.com -> Downloads -> Declaration -> Type: EU Declaration -> Product Code: ...

EU type-examination certificate

Certificate number:
KEMA 04 ATEX 1100 X

List of applied standards: See EU Declaration of Conformity.

Manufacturer address

Endress+Hauser SE+Co. KG
Hauptstraße 1
79689 Maulburg, Germany
Address of the manufacturing plant: See nameplate.

Other standards

Among other things, the following standards shall be observed in their current version for proper installation:

- IEC/EN 60079-14: "Explosive atmospheres - Part 14: Electrical installations design, selection and erection"
- EN 1127-1: "Explosive atmospheres - Explosion prevention and protection - Part 1: Basic concepts and methodology"

Extended order code

The extended order code is indicated on the nameplate, which is affixed to the device in such a way that it is clearly visible. Additional information about the nameplate is provided in the associated Operating Instructions.

Structure of the extended order code

PMC71, PMP7x	–	*****	+	A*B*C*D*E*F*G*..
<i>(Device type)</i>		<i>(Basic specifications)</i>		<i>(Optional specifications)</i>

* = Placeholder

At this position, an option (number or letter) selected from the specification is displayed instead of the placeholders.

Basic specifications

The features that are absolutely essential for the device (mandatory features) are specified in the basic specifications. The number of positions depends on the number of features available.

The selected option of a feature can consist of several positions.

Optional specifications

The optional specifications describe additional features for the device (optional features). The number of positions depends on the number of features available. The features have a 2-digit structure to aid identification (e.g. JA). The first digit (ID) stands for the feature group and consists of a number or a letter (e.g. J = Test, Certificate). The second digit constitutes the value that stands for the feature within the group (e.g. A = 3.1 material (wetted parts), inspection certificate).

More detailed information about the device is provided in the following tables. These tables describe the individual positions and IDs in the extended order code which are relevant to hazardous locations.

Extended order code: Cerabar S



The following specifications reproduce an extract from the product structure and are used to assign:

- This documentation to the device (using the extended order code on the nameplate).
- The device options cited in the document.

Device type

PMC71

Basic specifications

Position 1 (Approval)		
Selected option		Description
PMC71	8	ATEX II 1 G Ex ia IIC T6...T4/T3 Ga ATEX II 1 D Ex ia IIIC T ₂₀₀ 70°C Da

Position 2 (Output, Operating)		
Selected option		Description
PMC71	A, B, C	4-20 mA HART
	D, E, F	4-20 mA HART, L ₁ = 0
	M, N, O	PROFIBUS PA
	P, Q, R	FOUNDATION Fieldbus

Position 3 (Housing, Cover Sealing, Cable Entry)		
Selected option		Description
PMC71	A-E	T14, Alu IP66/67 NEMA6P; EPDM
	R-V	T17, 316L hygiene IP66/68 NEMA6P; EPDM
	1-5	T14, 316L IP66/67 NEMA6P; EPDM
	7, 8	T14, 316L IP66/67 NEMA6P; FVMQ

Position 10 (Additional Option 1)		
Selected option		Description
PMC71	M	Overvoltage protection
	T	High temperature version max 150°C/300°F

Position 11 (Additional Option 2)		
Selected option		Description
PMC71	M	Overvoltage protection
	T	High temperature version max 150°C/300°F

Optional specifications

No options specific to hazardous locations are available.



The following specifications reproduce an extract from the product structure and are used to assign:

- This documentation to the device (using the extended order code on the nameplate).
- The device options cited in the document.

Device type

PMP71, PMP75

Basic specifications

Position 1 (Approval)		
Selected option		Description
PMP7x	8	ATEX II 1 G Ex ia IIC T6...T4 Ga ATEX II 1 D Ex ia IIIC T ₂₀₀ 70°C Da

Position 2 (Output, Operating)		
Selected option		Description
PMP7x	A, B, C	4-20 mA HART
	D, E, F	4-20 mA HART, L ₁ = 0
	M, N, O	PROFIBUS PA
	P, Q, R	FOUNDATION Fieldbus

Position 3 (Housing, Cover Sealing, Cable Entry)		
Selected option		Description
PMP7x	A-E	T14, Alu IP66/67 NEMA6P; EPDM
	G, H	T14, Alu IP66/67 NEMA6P; FVMQ
	R-V	T17, 316L hygiene IP66/68 NEMA6P; EPDM
	1-5	T14, 316L IP66/67 NEMA6P; EPDM
	7, 8	T14, 316L IP66/67 NEMA6P; FVMQ

Position 11 (Additional Option 1)		
Selected option		Description
PMP7x	M	Overvoltage protection

Position 12 (Additional Option 2)		
Selected option		Description
PMP7x	M	Overvoltage protection

Optional specifications

ID Jx (Test, Certificate)		
Selected option		Description
PMP7x	JN	Ambient temperature transmitter -50 °C/-58 °F

**Safety
instructions:
General**

- The device is intended to be used in explosive atmospheres as defined in the scope of EN IEC 60079-0 or equivalent national standards. If no potentially explosive atmospheres are present or if additional protective measures have been taken: The device may be operated according to the manufacturer's specifications.
- Comply with the installation and safety instructions in the Operating Instructions.
- Staff must meet the following conditions for mounting, electrical installation, commissioning and maintenance of the device:
 - Be suitably qualified for their role and the tasks they perform
 - Be trained in explosion protection
 - Be familiar with national regulations
- Install the device according to the manufacturer's instructions and national regulations.
- Only use the device in media to which the wetted materials have sufficient durability.
- Avoid electrostatic charging:
 - Of plastic surfaces (e.g. enclosure, sensor element, special varnishing, attached additional plates, ..)
 - Of isolated capacities (e.g. isolated metallic plates)

**Safety
instructions:
Special conditions**

- For light metal flanges or flange faces (e.g. titanium, zirconium), avoid sparks caused by impact and friction.
- Install the device to exclude sparks caused by impact and friction on the aluminium enclosure and/or a light-metal process connection.
- To avoid electrostatic charging: Do not rub surfaces with a dry cloth.
- In the event of additional or alternative special varnishing on the enclosure or other metal parts or for adhesive plates:
 - Observe the danger of electrostatic charging and discharge.
 - Do not install in the vicinity of processes (≤ 0.5 m) generating strong electrostatic charges.

Safety instructions: Installation

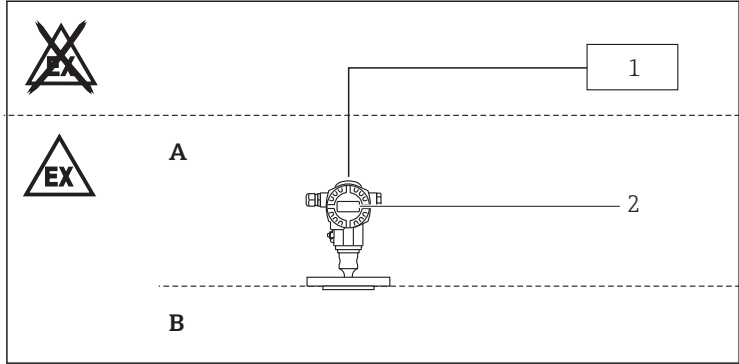

1

- A Zone 0, Zone 20, Electronic
 B Zone 0, Zone 20, Process
 1 Certified associated apparatus
 2 PMC71, PMP71, PMP75

- After aligning (rotating) the enclosure, retighten the fixing screw.
- The device is designed for operation in Zone 0 or Zone 20. In the event of potentially explosive gas-air and dust-air mixtures occurring simultaneously: Suitability requires further assessment.

Intrinsic safety

- The intrinsically safe input power circuit of the device is isolated from ground. The dielectric strength is at least $500 V_{\text{rms}}$.
- When the device is connected to an intrinsically safe circuit Ex ib, the type of protection changes to Ex ib. Do not operate intrinsically safe circuits Ex ib in Zone 0 or Zone 20.
- When the device is connected to an intrinsically safe circuit Ex ic, the type of protection changes to Ex ic. Do not operate intrinsically safe circuits Ex ic in Zone 0, Zone 1 or Zone 20, Zone 21.

Overvoltage protection

Device type PMC71, Basic specification, Position 10 + 11 = M

Device type PMP71, PMP75, Basic specification, Position 11 + 12 = M

The intrinsically safe input power circuit of the device is isolated from ground. The dielectric strength is at least $290 V_{\text{rms}}$.

Temperature tables

II 1 G Ex ia IIC T6...T4/T3 Ga

Temperature class	Process temperature T_p (process)	Ambient temperature range
T6	$\leq 80\text{ °C}$	$-40\text{ °C} \leq T_a \leq +40\text{ °C}$
T4	$\leq 120\text{ °C}^{1)}$	$-40\text{ °C} \leq T_a \leq +70\text{ °C}$
T3	$\leq 150\text{ °C}^{2)}$	$-40\text{ °C} \leq T_a \leq +70\text{ °C}$

- 1) Only Device type PMC71, PMP71
 2) Only Device type PMC71 with Basic specification, Position 10 + 11 = T

II 1 D Ex ia IIIC T₂₀₀ 70°C Da

Max. surface temperature at max. ambient temperature	Basic specification, Position 2 =	Process temperature range	Ambient temperature range
T70 °C	A, B, C, D, E, F	$-40\text{ °C} \leq T_p \leq +40\text{ °C}$	$-40\text{ °C} \leq T_a \leq +40\text{ °C}$
	M, N, O, P, Q, R	$-40\text{ °C} \leq T_p \leq +34\text{ °C}$	$-40\text{ °C} \leq T_a \leq +34\text{ °C}$



Device type PMC71, PMP71

- The process temperatures refer to the temperature at the separation membrane.
- Do not exceed the max. ambient temperature at the enclosure.

Device type PMP75

- Higher temperatures are permitted depending on the type of diaphragm seal.
- Do not exceed the max. ambient temperature at the enclosure.

Optional specification, ID Jx = JN

Lower limit of the ambient temperature for explosion protection changes to -50 °C .

Connection data

Basic specification, Position 2 = A, B, C, D, E, F

Power supply
$U_1 \leq 30\text{ V}_{DC}$ $I_1 \leq 300\text{ mA}$ $P_1 \leq 1\text{ W}$ $C_1 \leq 11.8\text{ nF}$ $L_1 \leq 225\text{ }\mu\text{H}^{1)}$ or $L_1 = 0^{2)}$

- 1) Basic specification, Position 2 = A, B, C
 2) Basic specification, Position 2 = D, E, F

Basic specification, Position 2 = M, N, O, P, Q, R

Power supply	
FISCO	Entity
$U_i \leq 17.5 \text{ V}_{\text{DC}}$	$U_i \leq 24 \text{ V}_{\text{DC}}$
$I_i \leq 500 \text{ mA}$	$I_i \leq 250 \text{ mA}$
$P_i \leq 5.5 \text{ W}$	$P_i \leq 1.2 \text{ W}$
$C_i \leq 5 \text{ nF}$	$C_i \leq 5 \text{ nF}$
$L_i \leq 10 \text{ } \mu\text{H}$	$L_i \leq 10 \text{ } \mu\text{H}$



71549583

www.addresses.endress.com
