

Operating Instructions

Accessories for the Rxn-20 probe

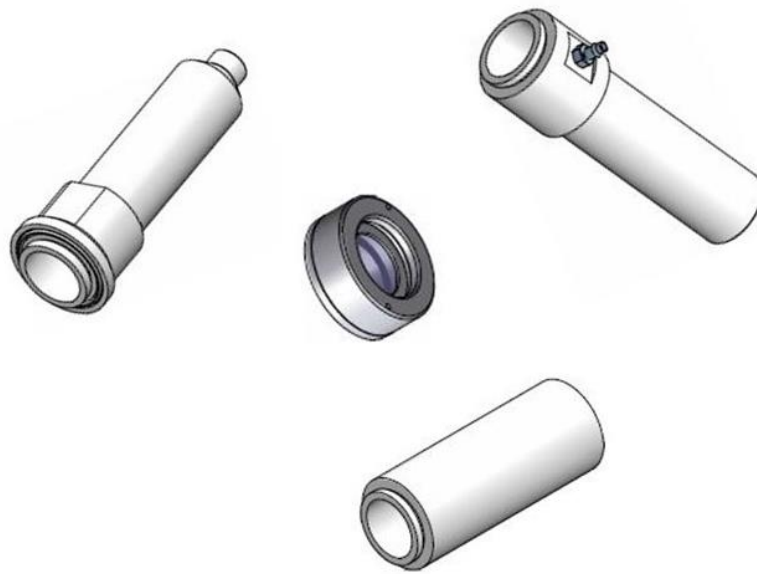

Table of Contents

1 About this document.....	4	4.1 Incoming acceptance	10
1.1 Warnings.....	4	4.2 Product identification	10
1.2 Symbols on the device.....	4	5 Installation	11
1.3 U.S. export compliance	4	6 Commissioning.....	12
1.4 Glossary	5	6.1 Receipt of accessories	12
2 Basic safety instruction	6	6.2 Calibration and verification	12
2.1 Requirements for the personnel.....	6	7 Operation	13
2.2 Designated use	6	8 Diagnostics and troubleshooting.....	14
2.3 Workplace safety.....	6	9 Maintenance.....	15
2.4 Operational safety.....	7	9.1 Cleaning the lens adapter or immersion optic... 15	
2.5 Service safety	7	10 Repair	16
2.6 Important safeguards	7	11 Technical data	17
2.7 Product safety.....	7	11.1 Lens adapters	17
3 Product description	8	11.2 Lens tubes	17
3.1 Lens adapter	9	11.3 Immersion optics.....	18
3.2 Lens tube	9	12 Supplementary documentation	19
3.3 Immersion optic.....	9	13 Index.....	20
4 Incoming product acceptance and product identification	10		

1 About this document

This manual provides information about the accessories used with the Endress+Hauser Rxn-20 Raman spectroscopic probe. The types of accessories available include:

- Lens adapters
- Lens tubes: non-purged and purgeable
- Immersion optics

Refer to the *Rxn-20 Raman spectroscopic probe Operating Instructions* for specific probe-related information.

1.1 Warnings

Structure of Information	Meaning
<p>⚠ WARNING</p> <p>Causes (/consequences) If necessary, consequences of non-compliance (if applicable)</p> <p>▶ Corrective action</p>	This symbol alerts you to a dangerous situation. Failure to avoid the dangerous situation can result in a fatal or serious injury.
<p>⚠ CAUTION</p> <p>Causes (/consequences) If necessary, consequences of non-compliance (if applicable)</p> <p>▶ Corrective action</p>	This symbol alerts you to a dangerous situation. Failure to avoid this situation can result in minor or more serious injuries.
<p>NOTICE</p> <p>Cause/situation If necessary, consequences of non-compliance (if applicable)</p> <p>▶ Action/note</p>	This symbol alerts you to situations which may result in damage to property.

Table 1. Warnings

1.2 Symbols on the device





Symbol	Description
	The Laser Radiation symbol is used to alert the user to the danger of exposure to hazardous visible laser radiation when using the system.
	The High Voltage symbol that alerts people to the presence of electric potential large enough to cause injury or damage. In certain industries, high voltage refers to voltage above a certain threshold. Equipment and conductors that carry high voltage warrant special safety requirements and procedures.
	The WEEE symbol indicates that the product should not be discarded as unsorted waste but must be sent to separate collection facilities for recovery and recycling.
	The CE Marking indicates conformity with health, safety, and environmental protection standards for products sold within the European Economic Area (EEA).

Table 2. Symbols

1.3 U.S. export compliance

The policy of Endress+Hauser is strict compliance with U.S. export control laws as detailed in the website of the [Bureau of Industry and Security](#) at the U.S. Department of Commerce.

1.4 Glossary

Term	Description
°C	Celsius
°F	Fahrenheit
FFKM	Perfluoroelastomers
HCA	Raman Calibration Accessory
in.	inches
m	meter
mm	millimeter
nm	nanometer
PTFE	polytetrafluoroethylene (Teflon)
WEEE	Waste Electrical and Electronic Equipment

Table 3. Glossary

2 Basic safety instruction

The safety information in this section is specific to the accessories that are compatible with the Rxn-20 Raman spectroscopic probe. Refer to the *Rxn-20 Raman spectroscopic probe Operating Instructions* for additional information related to probe and laser safety.

2.1 Requirements for the personnel

- Installation, commissioning, operation, and maintenance of the probe/optics may be carried out only by specially trained technical personnel.
- The technical personnel must be authorized by the plant operator to carry out the specified activities.
- The technical personnel must have read and understood these Operating Instructions and must follow the instructions contained herein.
- The facility must designate a laser safety officer who ensures staff are trained on all Class 3B laser operating and safety procedures.
- Faults at the measuring point may only be rectified by authorized trained personnel. Repairs not described in this document must be carried out only directly at the manufacturer's site or by the service organization.

2.2 Designated use

The Rxn-20 Raman spectroscopic probe is intended for the measurement of solids, semi-solids, and liquids in a laboratory or process development or manufacturing setting. The probe is compatible with a wide range of accessories to meet the requirements of different applications.

Accessory	Description of use
Lens adapter	The Rxn-20 probe is capable of measuring at various spot sizes from 1 to 6 mm (0.04 to 0.24 in.) depending on the lens adapter used. <ul style="list-style-type: none"> ▪ Larger spot size lenses have a larger focus tolerance, which enables focus-free measurements of uneven solid beds or samples. ▪ Smaller spot size lenses provide representative measurements of smaller-sized solids or turbid media.
Lens tube	The Rxn-20 probe and lens adapter may be supplemented by a purgeable or non-purged lens tube accessory. <ul style="list-style-type: none"> ▪ The purgeable lens tube accessory is designed to allow a low-flow of an appropriate gas to prevent material obscuring the probe lens. The lens tube interfaces the Rxn-20 probe to a coater or other batch operations where maintaining the cleanliness of the lens is necessary. ▪ The non-purged lens tube accessory is compatible with the sample chamber, allowing for easy analysis in laboratory applications.
Immersion optic	Another add-on to the Rxn-20 lens adapter is an immersion optic, which enables direct sample contact with slurries and liquids (either <i>in situ</i> or off-line).

Table 4. Designated use of accessories

Use of the device for any purpose other than that described, poses a threat to the safety of people and of the entire measuring system and invalidates any warranty.

2.3 Workplace safety

As the user, you are responsible for complying with the following safety conditions:

- Installation guidelines
- Local standards and regulations for electromagnetic compatibility

2.4 Operational safety

Before commissioning the entire measuring point:

1. Verify that all connections are correct.
2. Ensure that electrical and optical fiber cables are undamaged.
3. Ensure fluid level is sufficient for probe/optics immersion (if applicable).
4. Do not operate damaged products, and protect them against unintentional operation.
5. Label damaged products as defective.

During operation:

1. If faults cannot be rectified, products must be taken out of service and protected against unintentional operation.
2. When working with laser devices, always follow all local laser safety protocols which may include the use of personal protective equipment and limiting device access to authorized users.

2.5 Service safety

Follow your company's safety instructions when removing a process probe/accessory from the process interface for service. Always wear proper protective equipment when servicing the equipment.

2.6 Important safeguards





- Do not use the accessories for anything other than their intended use.
- Do not look directly into the laser beam.
- Do not point the laser at a mirrored/shiny surface or a surface that may cause diffuse reflections. The reflected beam is as harmful as the direct beam.
- Do not leave attached and unused probes uncapped or unblocked.
- Always use a laser beam block to avoid inadvertent scatter of laser radiation.

2.7 Product safety

The product is designed to meet all current safety requirements, has been tested, and shipped from the factory in a safe operating condition. The relevant regulations and international standards have been observed. Devices connected to an analyzer must comply with the applicable analyzer safety standards.

3 Product description

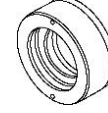
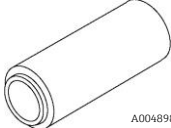
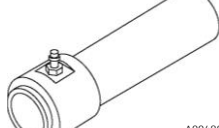
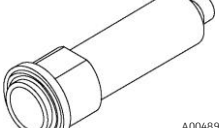
The variety of optics available for the Rxn-20 Raman spectroscopic probe, powered by Kaiser Raman technology, enables flexible sampling options of solids, semi-solids, and liquids in a laboratory or process plant setting. The accessories and available sizes are shown below.

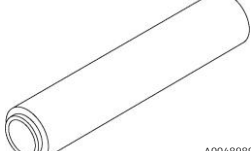
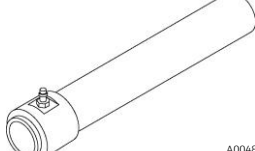
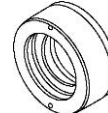
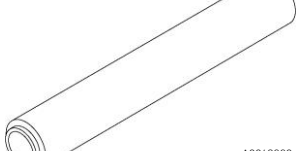
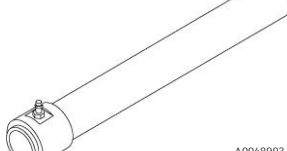
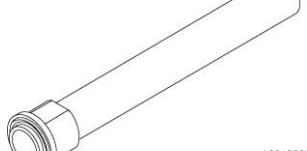
Spot size	Lens adapters 38.1 mm (1.50 in.) diameter	Lens tubes: non-purged 31.8 mm (1.25 in.) diameter	Lens tubes: purgeable 25.4 mm (1.00 in.) diameter	Immersion optics 25.4 mm (1.00 in.) diameter
	316 stainless steel, PTFE	Aluminum alloy 6061-T651, anodized black	316 stainless steel with 303 stainless barbed nipple	316 stainless steel, FFKM, PTFE, sapphire
1 mm (0.04 in.)	 *	X	X	X
1.5 mm (0.06 in.)	 *	X	X	X
3 mm (0.12 in.)				
4.7 mm (0.19 in.)				X
6 mm (0.24 in.)				

*Compatible with small sample chamber using 76.2 mm (3.00 in.) lens tube mounted between the probe body and lens adapter

Table 5. Accessories for Rxn-20 probe

3.1 Lens adapter

The Rxn-20 probe is capable of measuring at various spot sizes from 1 to 6 mm (0.04 to 0.24 in.) depending on the lens adapter used. In general, larger spot size lenses have a larger focus tolerance, which enables focus-free measurements of uneven solid beds or samples. Smaller spot size lenses provide representative measurements of smaller-sized solids or turbid media.

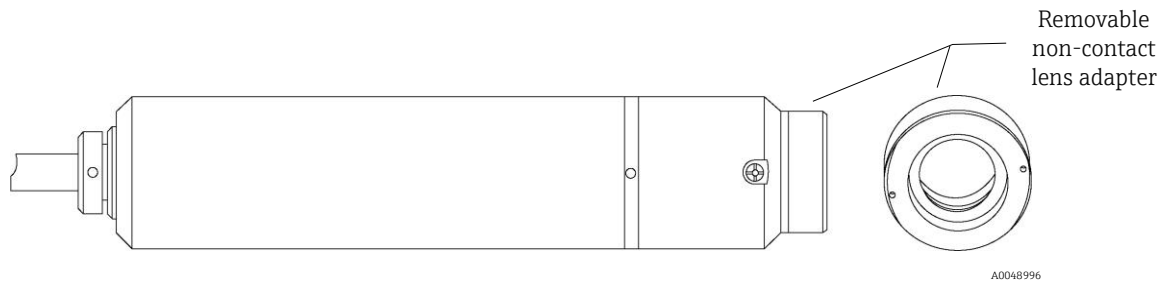

Figure 1. Rxn-20 probe with lens adapter

3.2 Lens tube

The Rxn-20 probe and lens adapter may be supplemented by a purgeable or non-purged lens tube accessory.

- The purgeable lens tube accessory is designed to allow a low-flow of an appropriate gas to prevent material obscuring the probe lens. The lens tube interfaces the Rxn-20 probe to a coater or other batch operations where maintaining the cleanliness of the lens is necessary.
- The non-purged lens tube accessory is compatible with the sample chamber, allowing for easy analysis in laboratory applications.

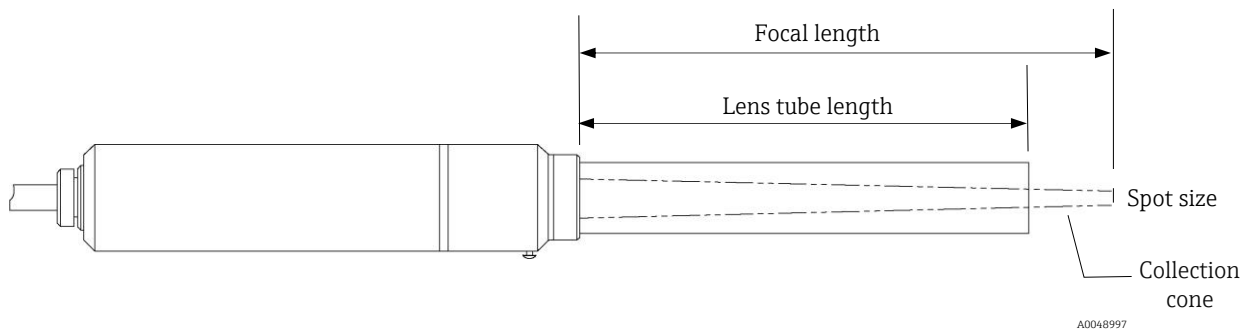

Figure 2. Rxn-20 probe with lens adapter and non-purged lens tube

3.3 Immersion optic

Another optional add-on to the Rxn-20 lens adapter is an immersion optic, which enables direct sample contact with slurries and liquids (either *in situ* or off-line).

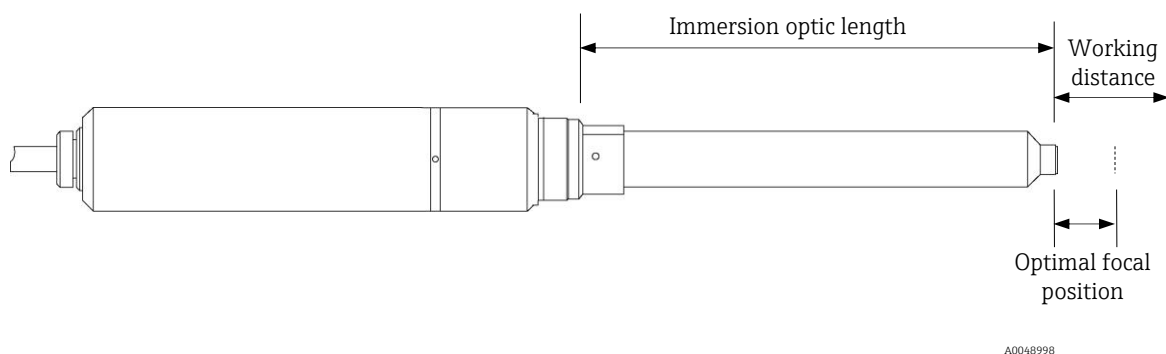

Figure 3. Rxn-20 probe with lens adapter and immersion optic

4 Incoming product acceptance and product identification

4.1 Incoming acceptance

1. Verify that the packaging is undamaged. Notify the supplier of any damage to the packaging. Keep the damaged packaging until the issue has been resolved.
2. Verify that the contents are undamaged. Notify the supplier of any damage to the delivery contents. Keep the damaged goods until the issue has been resolved.
3. Check that the delivery is complete and nothing is missing. Compare the shipping documents with your order.
4. Pack the product for storage and transportation in such a way that it is protected against impact and moisture. The original packaging offers the best protection. Make sure to comply with the permitted ambient conditions.

If you have any questions, please contact your supplier or your local sales center.

NOTICE

Incorrect transportation can damage the optics.

4.2 Product identification

4.2.1 Label

At a minimum, the lens adapters are labeled with the following information:

- Serial number
- Focal length
- Spot size

Compare the information on the label with the order.

4.2.2 Manufacturer address

Endress+Hauser
371 Parkland Plaza
Ann Arbor, MI 48103 USA

4.2.3 Scope of delivery

The scope of delivery comprises:

- Selected accessories
- *Accessories for the Rxn-20 probe Operating Instructions* manual

If you have any queries, please contact your supplier or local sales center.

5 Installation

The installation information in this section is specific to the accessories that are compatible with the Rxn-20 Raman spectroscopic probe. Refer to the *Rxn-20 Raman spectroscopic probe Operating Instructions* for additional information related to probe installation.

To attach an accessory to the Rxn-20 probe, simply thread the accessory onto the probe so that it is snug.

When replacing a lens adapter or immersion optic, use the Raman Calibration Accessory (HCA) to perform an intensity calibration for that probe with the new accessory.

6 Commissioning

The Rxn-20 probe comes equipped with the 6 mm (0.24 in.) spot size lens adapter attached. Other lens adapters and accessories are available separately and are delivered ready to connect to the probe.

No additional alignment or adjustment to the probehead is required. Follow the instructions below to commission the accessories for use in conjunction with the probe.

6.1 Receipt of accessories

Perform the steps for incoming product acceptance described in Section 4.1 → .

6.2 Calibration and verification

The probe and the analyzer must be calibrated before use.

6.2.1 Raman Calibration Accessory

After installing or changing a lens adapter or immersion optic on the probehead, use the Raman Calibration Accessory (HCA) to perform an intensity calibration for the probehead with the new accessory before use.

Refer to the *Raman Calibration Accessory Operating Instructions* for additional information about the HCA and adapters.

6.2.2 Performing calibration and verification

Refer to the applicable Raman Rxn analyzer operating instructions for steps to:

- Perform internal analyzer calibration; may include alignment calibration, full wavelength calibration, or full laser wavelength calibration depending on status of analyzer
- Perform probe calibration; requires HCA with an appropriate optic adapter
- Perform probe verification; verifies the calibration results using a standard reference sample
- View calibration and verification reports

The Raman RunTime software will not allow spectra to be collected without passing internal and probe calibrations. Passing the probe verification step is not required but highly recommended.

Raman Rxn analyzer operating instructions are available by searching the Downloads area of the Endress+Hauser web site: <https://endress.com/downloads>

7 Operation

This manual provides information about the accessories used with the Endress+Hauser Rxn-20 Raman spectroscopic probe. The Rxn-20 probe is optimized for large volumetric measurements, enabling representative, focus-free, quantitative Raman measurements of solids, semi-solids, and liquids in a laboratory or process plant setting.

The Rxn-20 probe is designed to be compatible with Endress+Hauser Raman Rxn2/Rxn4 (hybrid configuration) analyzers operating at 785 nm.

The Rxn-20 probe accepts a variety of accessories including:

- Lens adapters
- Lens tubes: non-purged and purgeable
- Immersion optics

The accessories are installed on the probe following the instructions in Section 5 → .

Refer to the *Rxn-20 Raman spectroscopic probe Operating Instructions* for operation of the probe with the accessories. Standard precautions for laser products should be observed.

8 Diagnostics and troubleshooting

Refer to the *Rxn-20 Raman spectroscopic probe Operating Instructions* to troubleshoot issues with the Rxn-20 probe and accessories.

9 Maintenance

9.1 Cleaning the lens adapter or immersion optic

If the lens adapter or immersion optic has come in contact with a sample, it may need to be cleaned. Use a lens wipe and a water-based lens cleaning solution to gently wipe away any contaminant. For more aggressive cleaning, use isopropyl alcohol and a lens wipe to gently wipe away any contaminant.

10 Repair

Repairs not described in this document must be carried out only directly at the manufacturer's site or by the service organization. For Technical Service, refer to our website (<https://endress.com/contact>) for the list of local sales channels in your area.

If a product must be returned for repair or replacement, follow all decontamination procedures indicated by your service provider.

WARNING

Failure to properly decontaminate wetted parts before return can result in a fatal or serious injury.

To ensure swift, safe and professional product returns, please contact your service organization.

For additional product return information, refer to the following site and select the applicable market/region:
<https://www.endress.com/en/instrumentation-services/instrumentation-repair>

11 Technical data

Specifications for the Rxn-20 probe accessories are listed below.

11.1 Lens adapters

Item		Description
Working distance (focal length)	1 mm spot size (0.04 in.)	35 mm (1.38 in.)
	1.5 mm spot size (0.06 in.)	50 mm (1.97 in.)
	3 mm spot size (0.12 in.)	125 mm (4.93 in.)
	4.7 mm spot size (0.19 in.)	200 mm (7.88 in.)
	6 mm spot size (0.24 in.)	250 mm (9.84 in.)
Diameter		38.1 mm (1.50 in.)
Materials of construction		316 stainless steel PTFE Adhesive: ISO 10993 compliant Fused silica glass

Table 6. Lens adapter specifications

11.2 Lens tubes

Item		Description
Lens tube length: non-purged	1 mm spot size (0.04 in.)	Compatible with small sample chamber when 76.2 mm (3.00 in.) lens tube is mounted between the probe body and lens adapter
	1.5 mm spot size (0.06 in.)	
	3 mm spot size (0.12 in.)	76.2 mm (3.00 in.)
	4.7 mm spot size (0.19 in.)	152.4 mm (6.00 in.)
	6 mm spot size (0.24 in.)	203.2 mm (8.00 in.)
Lens tube length: purgeable	3 mm spot size (0.12 in.)	101.6 mm (4.00 in.)
	4.7 mm spot size (0.19 in.)	168.9 mm (6.65 in.)
	6 mm spot size (0.24 in.)	217.2 mm (8.55 in.)
Diameter	non-purged	31.8 mm (1.25 in.)
	purgeable	25.4 mm (1.00 in.)
Materials of construction	non-purged	Aluminum alloy 6061-T651, anodized black
	purgeable	316 stainless steel with 303 stainless barbed nipple

Table 7. Lens tube specifications

11.3 Immersion optics

Item		Description
Length	3 mm spot size (0.12 in.)	104.1 mm (4.10 in.)
	6 mm spot size (0.24 in.)	224.8 mm (8.85 in.)
Diameter		25.4 mm (1.00 in.)
Materials of construction		316 stainless steel FFKM PTFE Sapphire

Table 8. Immersion optics specifications

12 Supplementary documentation

All documentation is available:

- On the Endress+Hauser Operations App for smartphone/tablet
- In the Downloads area of the Endress+Hauser website: <https://endress.com/downloads>

Part number	Document type	Document title
KA01552C	Brief Operating Instructions	Accessories for the Rxn-20 probe Brief Operating Instructions
TI01636C	Technical Information	Accessories for the Rxn-20 probe Technical Information

Table 9. Supplementary documentation

13 Index

- accessories
 - additional documents, 19
 - cleaning, 15
 - designated use, 6
 - installation, 11
 - materials of construction, 17, 18
 - operation, 13
 - receipt, 10
 - troubleshooting, 14
- glossary, 5
- probe
 - calibration, 11, 12
 - calibration accessory, 12
 - cap, 7
 - verification, 12
- Raman RunTime, 12
- Raman Rxn analyzer, 7, 12
- Raman Rxn analyzer (hybrid configuration), 13
- repair, 16
- safety, 7
 - basic, 6
 - operational, 7
 - product, 7
 - service, 7
 - workplace, 6
- specifications
 - diameter, 8, 17, 18
 - focal length, 17
 - length, 17, 18
- symbols, 4
- technical data, 17
- us export compliance, 4

www.addresses.endress.com
