

Safety Instructions

Liquicap M

FMI51, FMI52, FTI51, FTI52

II 1/2 G Ex ia IIC Ga/Gb

II 1/2 G Ex ia IIB Ga/Gb

II 1/2 D Ex ia IIIC Da/Db



Liquicap M FMI51, FMI52, FTI51, FTI52

Table of contents

Associated documentation	4
Supplementary documentation	4
Manufacturer's certificates	4
Manufacturer address	4
Other standards	4
Extended order code	5
Safety instructions: General	10
Safety instructions: Special conditions	10
Safety instructions: Installation	11
Safety instructions: Zone 20, Zone 21	13
Temperature tables	14
Connection data	17

Associated documentation	<p>This document is an integral part of the following Operating Instructions:</p> <ul style="list-style-type: none">■ BA00297F/00, BA00298F/00 (FMI51, FMI52)■ BA00299F/00 (FTI51, FTI52)
Supplementary documentation	<p>Explosion-protection brochure: CP00021Z/11</p> <p>The Explosion-protection brochure is available:</p> <ul style="list-style-type: none">■ In the download area of the Endress+Hauser website: www.endress.com -> Downloads -> Brochures and Catalogs -> Text Search: CP00021Z■ On the CD for devices with CD-based documentation
Manufacturer's certificates	<p>UK Declaration of Conformity</p> <p>Declaration Number: UK_00244</p> <p>The UK Declaration of Conformity is available: In the download area of the Endress+Hauser website: www.endress.com -> Downloads -> Declaration -> Type: UKCA Declaration -> Product Code: ...</p> <p>UKCA type-examination certificate</p> <p>Certificate number: CML 21UKEX2448X</p> <p>List of applied standards: See UK Declaration of Conformity.</p>
Manufacturer address	<p>Endress+Hauser SE+Co. KG Hauptstraße 1 79689 Maulburg, Germany</p> <p>Address of the manufacturing plant: See nameplate.</p>
Other standards	<p>Among other things, the following standards shall be observed in their current version for proper installation:</p> <ul style="list-style-type: none">■ IEC/EN 60079-14: "Explosive atmospheres - Part 14: Electrical installations design, selection and erection"■ EN 1127-1: "Explosive atmospheres - Explosion prevention and protection - Part 1: Basic concepts and methodology"

Extended order code

The extended order code is indicated on the nameplate, which is affixed to the device in such a way that it is clearly visible. Additional information about the nameplate is provided in the associated Operating Instructions.

Structure of the extended order code

FMI5x, FTI5x	-	*****	+	A*B*C*D*E*F*G*..
<i>(Device type)</i>		<i>(Basic specifications)</i>		<i>(Optional specifications)</i>

* = Placeholder

At this position, an option (number or letter) selected from the specification is displayed instead of the placeholders.

Basic specifications

The features that are absolutely essential for the device (mandatory features) are specified in the basic specifications. The number of positions depends on the number of features available.

The selected option of a feature can consist of several positions.

Optional specifications

The optional specifications describe additional features for the device (optional features). The number of positions depends on the number of features available. The features have a 2-digit structure to aid identification (e.g. JA). The first digit (ID) stands for the feature group and consists of a number or a letter (e.g. J = Test, Certificate). The second digit constitutes the value that stands for the feature within the group (e.g. A = 3.1 material (wetted parts), inspection certificate).

More detailed information about the device is provided in the following tables. These tables describe the individual positions and IDs in the extended order code which are relevant to hazardous locations.

Extended order code: Liquicap M



The following specifications reproduce an extract from the product structure and are used to assign:

- This documentation to the device (using the extended order code on the nameplate).
- The device options cited in the document.

Device type

FMI51, FMI52

Basic specifications

Position 1 (Approval)		
Selected option		Description
FMI51	C	ATEX II 1/2 G Ex ia IIC, II 1/2 D Ex ia IIIC
	D	ATEX II 1/2 G Ex ia IIC, II 1/2 D Ex ia IIIC, WHG
FMI5x	E	ATEX II 1/2 G Ex ia IIB, II 1/2 D Ex ia IIIC
	F	ATEX II 1/2 G Ex ia IIB, II 1/2 D Ex ia IIIC, WHG
	H	ATEX II 1/2 G Ex ia IIC, II 1/2 D Ex ia IIIC, note safety instruction (XA) (electrostatic charging)!
	J	ATEX II 1/2 G Ex ia IIC, II 1/2 D Ex ia IIIC, WHG, note safety instruction (XA) (electrostatic charging)!
	K	ATEX II 1/2 G Ex ia IIC, WHG, note safety instruction (XA) (electrostatic charging)!

Position 3 (Active Probe length L1, Insulation)		
Selected option		Description
FMI51	A, B, C, D, H, K, M, N mm/in, rod, 316L
	E, F, G, P, R, S mm/in, rod, 316L + ground tube
FMI52	A, B, C, D mm/in, 316

Position 7 (Electronics, Output)		
Selected option		Description
FMI5x	1	FEI50H; 4-20mA HART + display + UK marking
	2	FEI50H; 4-20mA HART + UK marking
	3	FEI57C; 2-wire PFM + UK marking

Position 8 (Housing)		
Selected option		Description
FMI5x	1	F15 316L hygiene IP66/67 NEMA4X
	2	F16 Polyester IP66/67 NEMA4X
	3	F17 Alu IP66/67 NEMA4X
	4	F13 Alu IP66 NEMA4X + gas-tight probe seal
	5	T13 Alu IP66 NEMA4X + gas-tight probe seal + separate conn. compartment
	6	F27 316L IP66/67 NEMA6P + gas-tight probe seal

Position 9 (Cable Entry)		
Selected option		Description
FMI5x	A	Gland M20
	B	Thread G1/2
	C	Thread NPT1/2
	D	Thread NPT3/4
	E	Plug M12
	F	Plug 7/8"

Position 10 (Type of Probe)		
Selected option		Description
FMI5x	1	Compact
	2, 3, 4, 5 mm/in, L4 cable > separate enclosure

Optional specifications

No options specific to hazardous locations are available.



The following specifications reproduce an extract from the product structure and are used to assign:

- This documentation to the device (using the extended order code on the nameplate).
- The device options cited in the document.

Device type

FTI51, FTI52

Basic specifications

Position 1 (Approval)		
Selected option	Description	
FTI51	C	ATEX II 1/2 G Ex ia IIC, II 1/2 D Ex ia IIIC
	D	ATEX II 1/2 G Ex ia IIC, II 1/2 D Ex ia IIIC, WHG
FTI5x	H	ATEX II 1/2 G Ex ia IIC, II 1/2 D Ex ia IIIC, note safety instruction (XA) (electrostatic charging)!
	J	ATEX II 1/2 G Ex ia IIC, II 1/2 D Ex ia IIIC, WHG, note safety instruction (XA) (electrostatic charging)!
	K	ATEX II 1/2 G Ex ia IIC, WHG, note safety instruction (XA) (electrostatic charging)!

Position 3 (Active Probe length L1; Insulation)		
Selected option	Description	
FTI51	A, B, C, D, H, K, M, N, T, 1 mm/in, rod, 316L
	E, F, G, P, R, S mm/in, rod, 316L + ground tube
FTI52	A, B, C, D mm/in, 316

Position 8 (Electronics, Output)		
Selected option	Description	
FTI5x	F	FEI55; 8/16 mA, 11-35 VDC + UK marking
	G	FEI57S; 2-wire PFM + UK marking
	H	FEI58; NAMUR + test button (H-L signal) + UK marking

Position 9 (Housing)		
Selected option		Description
FTI5x	1	F15 316L hygiene IP66/67 NEMA4X
	2	F16 Polyester IP66/67 NEMA4X
	3	F17 Alu IP66/67 NEMA4X
	4	F13 Alu IP66 NEMA4X + gas-tight probe seal
	5	T13 Alu IP66 NEMA4X + gas-tight probe seal + separate conn. compartment
	6	F27 316L IP66/67 NEMA6P + gas-tight probe seal

Position 10 (Cable Entry)		
Selected option		Description
FTI5x	A	Gland M20
	B	Thread G1/2
	C	Thread NPT1/2
	D	Thread NPT3/4
	E	Plug M12
	F	Plug 7/8"

Position 11 (Type of probe)		
Selected option		Description
FTI5x	1	Compact
	2, 3, 4, 5 mm/in, L4 cable > separate enclosure

Optional specifications

No options specific to hazardous locations are available.

Safety instructions:
General

- The device is intended to be used in explosive atmospheres as defined in the scope of EN IEC 60079-0 or equivalent national standards. If no potentially explosive atmospheres are present or if additional protective measures have been taken: The device may be operated according to the manufacturer's specifications.
- Staff must meet the following conditions for mounting, electrical installation, commissioning and maintenance of the device:
 - Be suitably qualified for their role and the tasks they perform
 - Be trained in explosion protection
 - Be familiar with national regulations
- Install the device according to the manufacturer's instructions and national regulations.
- Only use the device in media to which the wetted materials have sufficient durability.
- Avoid electrostatic charging:
 - Of plastic surfaces (e.g. enclosure, sensor element, special varnishing, attached additional plates, ..)
 - Of isolated capacities (e.g. isolated metallic plates)

Safety instructions:
Special conditions

- Avoid electrostatic charging of the probe (e.g. do not rub dry and install outside the filling flow).
- Do not use in areas where electrostatic charge caused by the process can occur.
- To avoid electrostatic charging: Do not rub surfaces with a dry cloth.
- In the event of additional or alternative special varnishing on the enclosure or other metal parts or for adhesive plates:
 - Observe the danger of electrostatic charging and discharge.
 - Do not install in the vicinity of processes (≤ 0.5 m) generating strong electrostatic charges.

Basic specification, Position 8 (FMI5x), 9 (FTI5x) = 2

- Only suitable for use in Zone 1!
- Avoid electrostatic charging of the enclosure (e.g. friction, cleaning, maintenance, strong medium flow).
- Do not clean the transparent cover in an explosive atmosphere.
- Application of a plug is only suitable for gas group IIB.

Basic specification, Position 8 (FMI5x), 9 (FTI5x) = 3, 4, 5

Avoid sparks caused by impact and friction.

Safety instructions: Installation

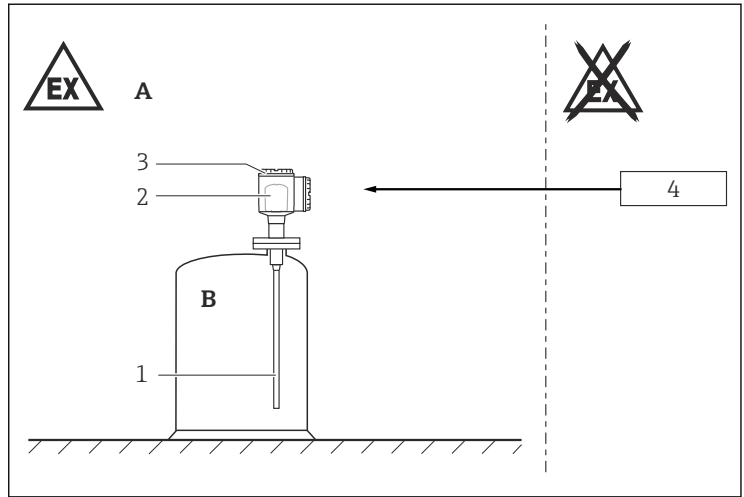

A003811

1

- A Zone 1, Zone 21
 B Zone 0, Zone 20
 1 Rope or rod probes
 2 Electronic insert
 3 Enclosure
 4 Certified associated apparatus



- Observe the maximum process conditions according to the manufacturer's Operating Instructions.
- At high medium temperatures, note flange pressure load capacity as a factor of temperature.
- Replace cable glands and sealing plugs only with identical parts.
- Perform the following to achieve the degree of protection:
 - Screw the cover tight.
 - Mount the cable entry correctly.
- Mechanically fix probes which are more than 3 m (e.g. using guy ropes).
- Level probes with ground tubes: Suitable for use in Group IIC, IIB, IIA and IIIC, IIIB, IIIA.
- Level probes without ground tubes: Suitable for use in Group IIC, IIB, IIA and IIIC, IIIB, IIIA, if avoiding electrostatic charging of the probe. Designation of the device with warning sign: "Avoid electrostatic charging".
- The device is designed for operation in Zone 1 or Zone 21 (enclosure) as well as Zone 0 or Zone 20 (probe). In the event of potentially explosive gas-air and dust-air mixtures occurring simultaneously: Suitability requires further assessment.

Basic specification, Position 8 (FMI5x), 9 (FTI5x) = 1
Tightening torque of the securing screw: max. 1 Nm.

Intrinsic safety

Observe the pertinent guidelines when interconnecting intrinsically safe circuits.

Potential equalization

Install potential equalization between the certified associated apparatus (non-hazardous area, ) and the device (explosion-hazardous area, ) .

Overvoltage protection

For installations which require overvoltage protection to comply with national regulations or standards, install the device using overvoltage protection (e.g. HAW56x from Endress+Hauser).

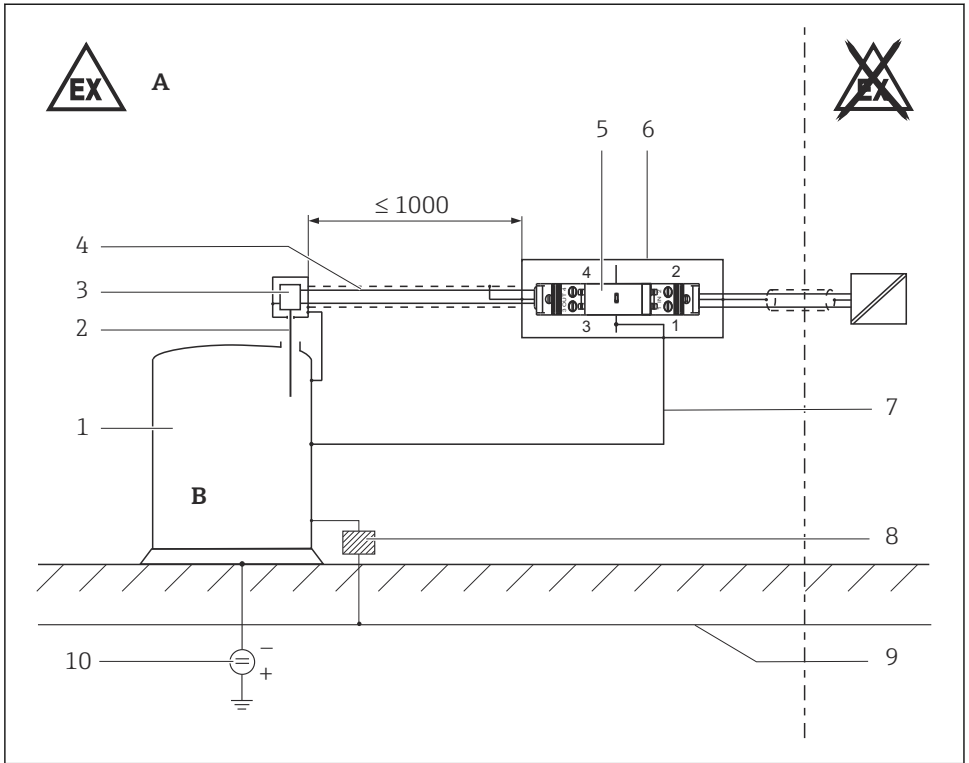

A0032138

2 Dimensions in mm

A Zone 1, Zone 21

B Zone 0, Zone 20

1 Tank

2 Probe

3 Electronic insert

4 e.g. metal hose, metal pipe

5 Overvoltage protection, e.g. HAW56xZ

6 Grounding via top-hat rail or 51003750 metallic protective enclosure

7 Potential equalization line $\geq 4 \text{ mm}^2 \text{ Cu}$

8 Insulator (optional)

9 Potential equalization

10 Cathodic protection (Object voltage $\leq 24 \text{ V}$), (optional)

Safety instructions:
Zone 20, Zone 21

- Seal the cable entry or piping tight.
- Do not open in a potentially explosive dust atmosphere.
- Avoid electrostatic charging of the sensor cable (e.g. do not rub dry and install outside the filling flow).

Zone 21

Only use cable and wire entries suitable for Zone 21 with the degree of protection IP66. Cable and wire entries must be suitable for an ambient temperature of at least -50 to $+90$ °C.

Basic specification, Position 8 (FMI5x), 9 (FTI5x) = 3, 4, 5, 6

Tighten the cover with torque 12 Nm.

Temperature tables

Application in gas

<i>Basic specification, Position 7 (FMI5x), 8 (FTI5x)</i>	Ambient temperature T_a (ambient): electronics	Temperature class
1, 2	$-50\text{ °C} \leq T_a \leq +60\text{ °C}$	T6
	$-50\text{ °C} \leq T_a \leq +70\text{ °C}$	T3...T5
3	$-50\text{ °C} \leq T_a \leq +60\text{ °C}$	T6
	$-50\text{ °C} \leq T_a \leq +70\text{ °C}$	T3...T5
F	$-50\text{ °C} \leq T_a \leq +55\text{ °C}$	T6
	$-50\text{ °C} \leq T_a \leq +70\text{ °C}$	T3...T5
G	$-50\text{ °C} \leq T_a \leq +55\text{ °C}$	T6
	$-50\text{ °C} \leq T_a \leq +70\text{ °C}$	T3...T5
H	$-50\text{ °C} \leq T_a \leq +60\text{ °C}$	T3...T6

	Ambient temperature T_a (ambient): electronics	Temperature class
<i>Restrictions for Basic specification, Position 8 (FMI5x), 9 (FTI5x) = 2</i>	$-40\text{ °C} \leq T_a \leq +55\text{ °C}$	T6
	$-40\text{ °C} \leq T_a \leq +60\text{ °C}$ or $+70\text{ °C}$, respectively	T3...T5

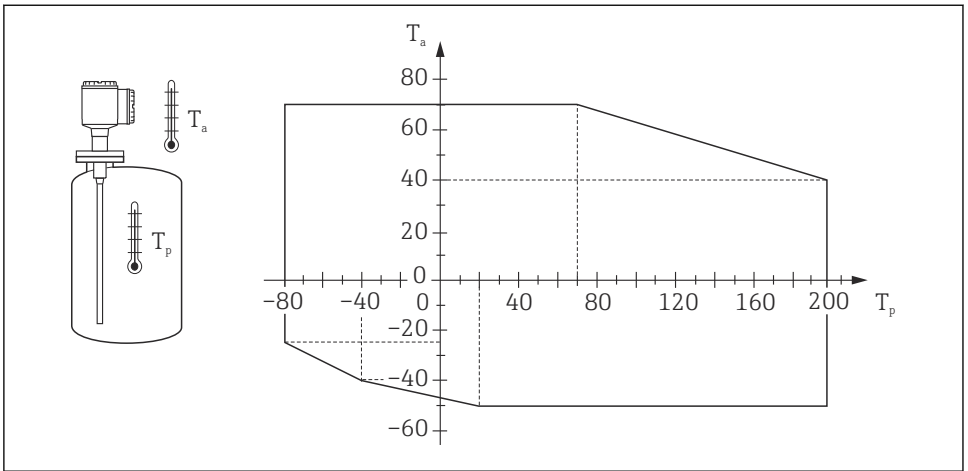
Compact version

A0032139

3

 T_a Ambient temperature in °C T_p Process temperature in °C

Version with separate enclosure

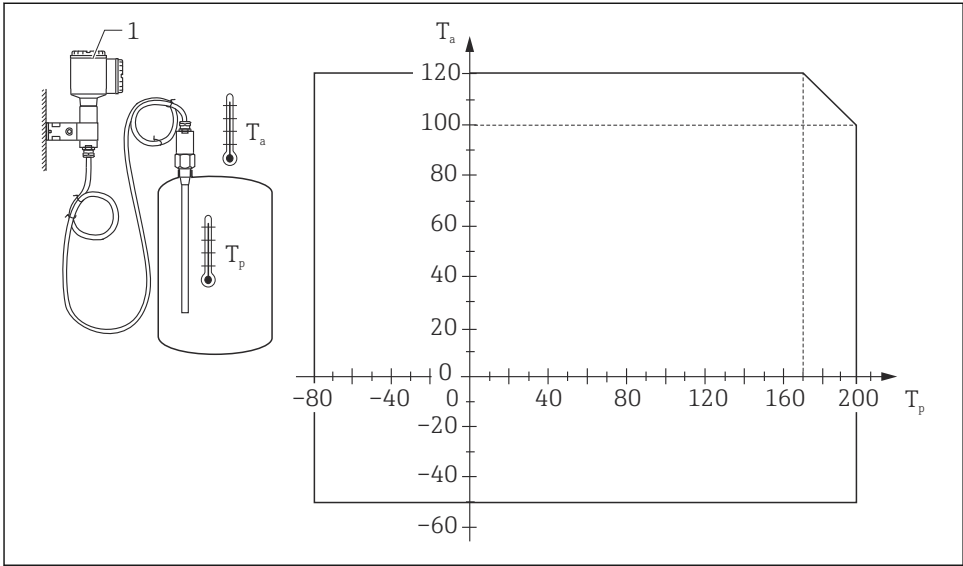

A0033507

4

T_a Ambient temperature in °C





T_p Process temperature in °C

1 Temperature at Basic specification, Position 10 (FMI5x), 11 (FTI5x) = 2, 3, 4, 5: ≤70 °C

Application in dust

Basic specification, Position 7 (FMI5x), 8 (FTI5x)	Ambient temperature T_a (ambient): electronics
1, 2, 3, F, G, H	$-50\text{ °C} \leq T_a \leq +70\text{ °C}$

	Probe in Zone 20	Electronics enclosure in Zone 21
Maximum permitted process or ambient temperature	$-50\text{ °C} \leq T_p \leq +200\text{ °C}$	$-50\text{ °C} \leq T_a \leq +70\text{ °C}$

	Probe in Zone 20	Electronics enclosure in Zone 21
Maximum surface temperature at a process temperature or ambient temperature of 40 °C	T_{200} 60 °C at $T_p = +40$ °C	T60 °C at $T_a = +40$ °C
Maximum surface temperature at a process temperature or ambient temperature of 70 °C	T_{200} 90 °C at $T_p = +70$ °C	T90 °C at $T_a = +70$ °C
Maximum surface temperature for probe process temperatures ≥ 80 to 180 °C, under compliance of the permitted ambient temperature at the electronics enclosure, →  3,  15, →  4,  16	T_{200} 100 °C at $T_p = +80$ °C	T90 °C at $T_a = +70$ °C
	T_{200} 200 °C at $T_p = +180$ °C	T90 °C at $T_a = +38$ °C

Connection data

Basic specification, Position 7 (FMI5x), 8 (FTI5x)	Electrical data
1, 2	$U_i \leq 30$ V $I_i \leq 120$ mA $P_i \leq 1$ W $L_i =$ negligible $C_i \leq 2.4$ nF
3	$U_i \leq 19.2$ V $I_i \leq 108$ mA $P_i \leq 1$ W $L_i =$ negligible $C_i \leq 2.4$ nF
F	$U_i \leq 35$ V $I_i \leq 100$ mA $P_i \leq 1$ W $L_i =$ negligible $C_i \leq 2.4$ nF
G	$U_i \leq 16.1$ V $I_i \leq 100$ mA $P_i \leq 1$ W $L_i =$ negligible $C_i \leq 2.4$ nF
H	$U_i \leq 18$ V $I_i \leq 52$ mA $P_i \leq 170$ mW $L_i =$ negligible $C_i =$ negligible

Cable entry parameters

Ex ia IIIC

Cable gland: *Basic specification, Position 9 (FMI5x), 10 (FTI5x) = A*

Basic specification, Position 8 (FMI5x), 9 (FTI5x) = 1, 3, 4, 5, 6

Thread	Clamping range	Material	Sealing insert	O-ring
M20x1,5	ø 8 to 10.5 mm ¹⁾ (ø 6.5 to 13 mm) ²⁾	Ms, nickel-plated	Silicone	EPDM (ø 17x2)

- 1) Standard
2) Separate clamping inserts available



- The tightening torque refers to cable glands installed by the manufacturer:
 - Recommended torque to connect the cable gland into the enclosure: 3.75 Nm
 - Recommended torque to tighten the cable into the cable gland: 3.5 Nm
 - Maximum torque to tighten the cable into the cable gland: 10 Nm
 - This value may be different depending on the type of cable. However, the maximum value must not be exceeded.
- Only suitable for fixed installation. The operator must pay attention to a suitable strain relief of the cable.
- To maintain the ingress protection of the enclosure: Install the enclosure cover, cable glands and blind plugs correctly.
- The cable glands are suitable for a low risk of mechanical danger (4 Joule) and must be mounted in a protected position if larger impact energy levels are expected.



71578840

www.addresses.endress.com
