

Safety Instructions

Soliphant M

FTM50, FTM51, FTM52

Ex db IIC T6...T1 Ga/Gb

Ex db IIC T6...T1 Gb

Ex tb IIIC Txxx°C Da/Db



Soliphant M FTM50, FTM51, FTM52

Table of contents

About this document	4
Associated documentation	4
Supplementary documentation	4
General notes: Combined approval	4
Manufacturer's certificates	5
Manufacturer address	5
Extended order code	5
Safety instructions: General	8
Safety instructions: Special conditions	8
Safety instructions: Installation	9
Safety instructions: Ex d joints	10
Safety instructions: Zone 0	10
Temperature tables	11
Connection data	22

About this document

 This document has been translated into several languages. Legally determined is solely the English source text.

Associated documentation

This document is an integral part of the following Operating Instructions:

- KA00229F (FTM50, FTM51)
- KA00230F (FTM52)
- TI00392F (FTM50, FTM51, FTM52)

Supplementary documentation

Explosion-protection brochure: CP00021Z

The Explosion-protection brochure is available:

- In the download area of the Endress+Hauser website:
www.endress.com -> Downloads -> Brochures and Catalogs -> Text Search: CP00021Z
- On the CD for devices with CD-based documentation

**General notes:
Combined approval**

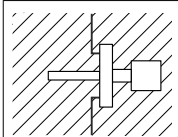
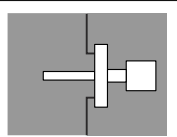
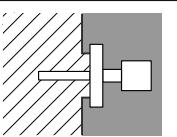
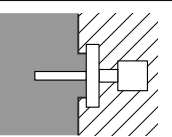
							
Ex db IIC	Zone 1	Ex tb IIIC	Zone 21	Ex db IIC	Zone 21	Ex tb IIIC	Zone 1
Zone 0 or Zone 1		Zone 20 or Zone 21		Zone 0 or Zone 1		Zone 20 or Zone 21	

The device is designed for operation in explosive gas or explosive dust atmosphere as shown in the sketch above. In the event of potentially explosive gas-air and dust-air mixtures occurring simultaneously: Suitability requires further assessment.

-  A sequential change between gas and dust explosion protection is only possible if:
- A period with non-explosive atmosphere is realized during the transition or
 - Special examinations are done which are not covered by the certificate

Manufacturer's certificates**NEPSI Declaration of Conformity**

Certificate number:
GYJ21.3323X

Affixing the certificate number certifies conformity with the following standards (depending on the device version):

- GB/T 3836.1-2021
- GB/T 3836.2-2021
- GB/T 3836.4-2021
- GB 3836.20-2010
- GB/T 3836.31-2021

Manufacturer address

Endress+Hauser SE+Co. KG
Hauptstraße 1
79689 Maulburg, Germany

Address of the manufacturing plant: See nameplate.

Extended order code

The extended order code is indicated on the nameplate, which is affixed to the device in such a way that it is clearly visible. Additional information about the nameplate is provided in the associated Operating Instructions.

Structure of the extended order code

FTM5x	-	*****	+	A*B*C*D*E*F*G*..
<i>(Device type)</i>		<i>(Basic specifications)</i>		<i>(Optional specifications)</i>

* = Placeholder

At this position, an option (number or letter) selected from the specification is displayed instead of the placeholders.

Basic specifications

The features that are absolutely essential for the device (mandatory features) are specified in the basic specifications. The number of positions depends on the number of features available.

The selected option of a feature can consist of several positions.

Optional specifications

The optional specifications describe additional features for the device (optional features). The number of positions depends on the number of

features available. The features have a 2-digit structure to aid identification (e.g. JA). The first digit (ID) stands for the feature group and consists of a number or a letter (e.g. J = Test, Certificate). The second digit constitutes the value that stands for the feature within the group (e.g. A = 3.1 material (wetted parts), inspection certificate).

More detailed information about the device is provided in the following tables. These tables describe the individual positions and IDs in the extended order code which are relevant to hazardous locations.

Extended order code: Soliphant M



The following specifications reproduce an extract from the product structure and are used to assign:

- This documentation to the device (using the extended order code on the nameplate).
- The device options cited in the document.

Device type

FTM50, FTM51, FTM52

Basic specifications

Position 1 (Approval)		
Selected option		Description
FTM50	Z	NEPSI Ex db IIC T6...T1 Ga/Gb NEPSI Ex db IIC T6...T1 Gb NEPSI Ex tb IIIC T160°C...T310°C ¹⁾ Da/Db
FTM51	Z	NEPSI Ex db [ia Ga] IIC T6...T1 Ga/Gb NEPSI Ex db [ia] IIC T6...T1 Gb NEPSI Ex tb [ia Da] IIIC T160°C...T310°C ¹⁾ Da/Db
FTM52	Z	NEPSI Ex db [ia Ga] IIC T6 Ga/Gb NEPSI Ex db [ia] IIC T6 Gb NEPSI Ex tb [ia Da] IIIC T90°C Da/Db

1) Depends on Basic specification, Position 11

Position 6 (Electronics, Output)		
Selected option		Description
FTM5x	1	FEM51; 2-wire 19-253VAC
	2	FEM52; 3-wire PNP 10-55VDC
	4	FEM54; relay DPDT, 19-253VAC/55VDC
	5	FEM55; 8/16mA, 11-35VDC

Position 7 (Type of Probe)		
Selected option		Description
FTM5x	A	Compact
	D, E	Cable > separate enclosure

Position 8 (Housing)		
Selected option		Description
FTM5x	H	T13 Alu IP66/68 NEMA Type 4X/6P Encl., separate conn. compartment
	5	F13 Alu IP66/68 NEMA Type 4X/6P Encl.
	6	F27 316L IP67/68 NEMA Type 4X/6P Encl.

Position 11 (Additional Option 2)		
Selected option		Description
FTM50	A	Not selected
FTM51	C	EN10204-3.1 material (wetted parts), inspection certificate
	D, E	Temp. separator $\leq 150^{\circ}\text{C}$
	F, H	High temperature $\leq 280^{\circ}\text{C}$
	J, K	High temperature $\leq 230^{\circ}\text{C}$
	Y	Special version: High temperature $\leq 300^{\circ}\text{C}$
FTM52	A	Not selected

Optional specifications

No options specific to hazardous locations are available.

Safety instructions:
General

- Comply with the installation and safety instructions in the Operating Instructions.
- Staff must meet the following conditions for mounting, electrical installation, commissioning and maintenance of the device:
 - Be suitably qualified for their role and the tasks they perform
 - Be trained in explosion protection
 - Be familiar with national regulations
- For installation, use and maintenance of the device, users must also observe the requirements stated in the Operating Instructions and the standards:
 - GB 50257-2014: "Code for construction and acceptance of electric device for explosion atmospheres and fire hazard electrical equipment installation engineering".
 - GB/T 3836.13-2021: "Explosive atmospheres, Part 13: Equipment repair, overhaul, reclamation and modification".
 - GB/T 3836.15-2017: "Explosive atmospheres, Part 15: Electrical installations design, selection and erection".
 - GB/T 3836.16-2017: "Explosive atmospheres, Part 16: Electrical installations inspection and maintenance".
 - GB 15577-2018: "Safety regulations for dust explosive prevention and protection". (Only if installed in dust hazardous area.)
- Install the device according to the manufacturer's instructions and national regulations.
- In potentially explosive atmospheres: Do not open the connection compartment cover and the electronics compartment cover when energized.
- Waiting time before opening the electronics compartment after switching off the power supply: 17 minutes.
- Avoid electrostatic charging:
 - Of plastic surfaces (e.g. enclosure, sensor element, special varnishing, attached additional plates, ..)
 - Of isolated capacities (e.g. isolated metallic plates)

Safety instructions:
Special conditions

- To avoid electrostatic charging: Do not rub surfaces with a dry cloth.
- In the event of additional or alternative special varnishing on the enclosure or other metal parts or for adhesive plates:
 - Observe the danger of electrostatic charging and discharge.
 - Do not install in the vicinity of processes (≤ 0.5 m) generating strong electrostatic charges.

Basic specification, Position 8 = H, 5

Avoid sparks caused by impact and friction.

Safety instructions: Installation

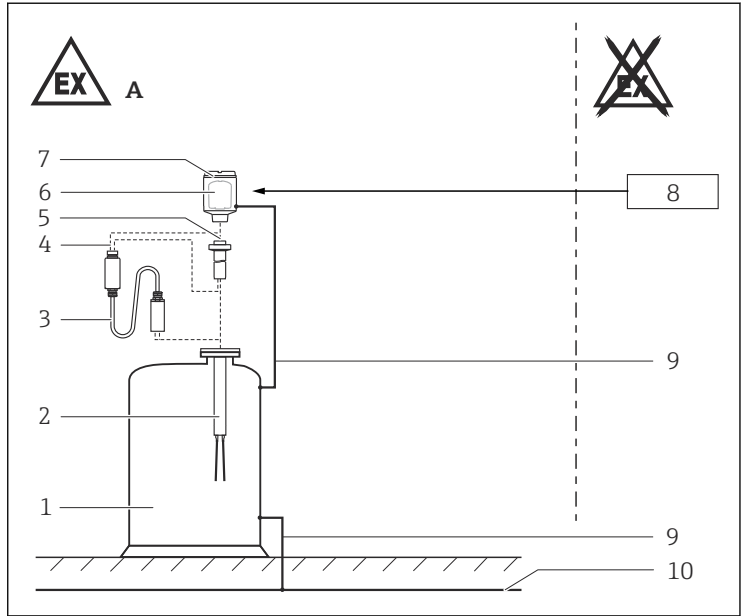

A0027398

1

- A Zone 1, Zone 20, Zone 21
 1 Tank; Hazardous area Zone 0, Zone 1, Zone 20
 2 Version
 3 Separate installation (optional)
 4 [Ex ia] circuit
 5 Temperature spacer (optional at 150 °C)
 6 Electronic insert
 7 Enclosure
 8 Supply unit
 9 Potential equalization
 10 Local potential equalization

- Observe the maximum process conditions according to the manufacturer's Operating Instructions.
- At high medium temperatures, note flange pressure load capacity as a factor of temperature.
- Connect the device:
 - Using suitable cable and wire entries of protection type "Flameproof Enclosure (Ex db)".
 - Using piping systems of protection type "Flameproof Enclosure (Ex db)".
 - To maintain the ingress protection of the enclosure IP66/67: Install the enclosure cover, cable glands and blind plugs correctly.
 - Seal unused entry glands with approved Ex db sealing plugs.

- Install the device to exclude any mechanical damage or friction during the application. Pay particular attention to flow conditions and tank fittings.
- Support extension tube of the device if a dynamic load is expected.
- Only use the device in media to which the wetted materials have sufficient durability (e.g. process connection seal).
- Use a process connection seal that meets the materials compatibility and temperature requirements.
- Flameproof equipment with G1/2 threaded entry holes is not intended for new installations but only for replacement of equipment in existing installations. Application of this equipment shall comply with the local installation requirements.
- When connecting the cables, ensure there is adequate strain relief at place of installation.
- Protect the connecting cable between the separate enclosure and the level sensor from tension and friction (e.g. due to electrostatic charge from medium flow).

Pole	Cross section connecting wire	Tightening torque of terminal screw	Stripped insulation
2/3	0.2 to 2.5 mm ²	≤ 0.4 Nm	6 to 8 mm
8	0.5 to 2.5 mm ²	–	8 to 9 mm

Safety instructions: Ex d joints

- If required or if in doubt: ask manufacturer for specifications.
- Flameproof joints are not intended to be repaired.







Safety instructions: Zone 0

- When using under non-atmospheric pressures and non-atmospheric temperatures: The sensor part of the device approved for Zone 0 does not cause any ignition hazards.
- For operation in accordance with manufacturer's specifications:
 - Permissible medium temperatures: dependent on ambient temperature
 - Permissible pressures: -1 to +25 bar, dependent on process connection (see Operating Instructions).

Temperature tables

Application in gas

The dependency of the ambient and process temperatures upon the temperature class:

Device type	Basic specification, Position	Temperature class	Process temperature T_p (process): sensor	Ambient temperature T_a (ambient): electronics
FTM50 FTM51	11 = D, E, J, K, F, H	T6	-50 to +80 °C	-50 to +60 °C
FTM52		T6	-40 to +80 °C	-40 to +60 °C
FTM50 FTM51	11 = D, E, J, K, F, H	T5	-50 to +95 °C	→  2,  12 →  4,  14 →  6,  16
FTM50 FTM51	11 = D, E, J, K, F, H	T4	-50 to +130 °C	
FTM50 FTM51	11 = D, E 11 = J, K, F, H	T3 T3	-50 to +150 °C -50 to +195 °C	
FTM50 FTM51	11 = J, K, F, H	T2	-50 to +230 °C/+290 °C	
FTM50 FTM51	11 = J, K, F, H	T1	-50 to +300 °C	

Compact version

Device type *FTM50, FTM51*

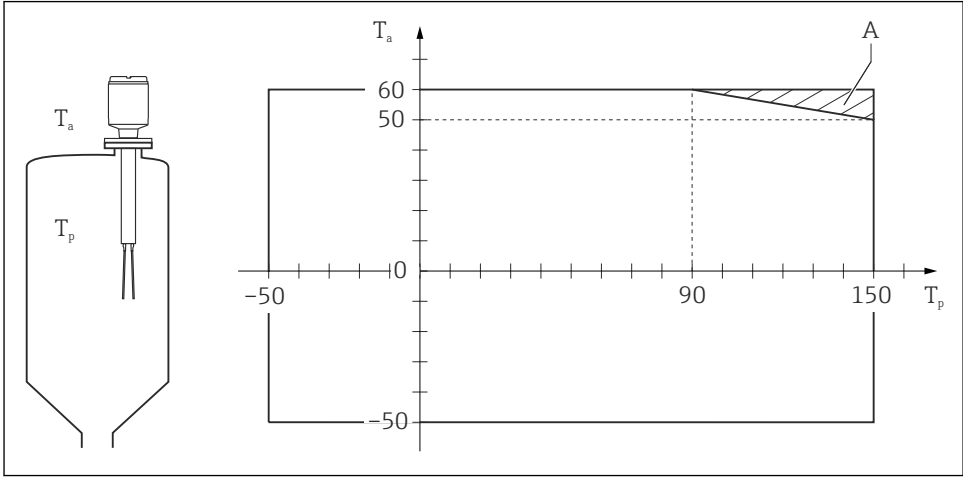

A0027399

2

T_a Ambient temperature in °C

T_p Process temperature in °C

A Additional temperature range for sensors with temperature spacer

Device type	Type of protection	Ambient temperature T_a (ambient): enclosure <i>Basic specification, Position 6</i>	Process temperature T_p (process)
FTM50	Ex db IIC T6...T1 Ga/Gb Ex db IIC T6...T1 Gb	$-50\text{ °C} \leq T_a \leq +60\text{ °C}$	$-50\text{ °C} \leq T_p \leq +230\text{ °C}$ $-50\text{ °C} \leq T_p \leq +290\text{ °C}$ $-50\text{ °C} \leq T_p \leq +300\text{ °C}$
	Ex db IIC T6...T3 Ga/Gb Ex db IIC T6...T3 Gb		$-50\text{ °C} \leq T_p \leq +150\text{ °C}$

Device type	Type of protection	Ambient temperature T_a (ambient): enclosure <i>Basic specification, Position 6</i>	Process temperature T_p (process)
FTM51	Ex db ia Ga IIC T6...T1 Ga/Gb Ex db ia IIC T6...T1 Gb	$-50\text{ °C} \leq T_a \leq +60\text{ °C}$	$-50\text{ °C} \leq T_p \leq +230\text{ °C}$ $-50\text{ °C} \leq T_p \leq +290\text{ °C}$ $-50\text{ °C} \leq T_p \leq +300\text{ °C}$
	Ex db ia Ga IIC T6...T3 Ga/Gb Ex db ia IIC T6...T3 Gb		$-50\text{ °C} \leq T_p \leq +150\text{ °C}$

Device type FTM52

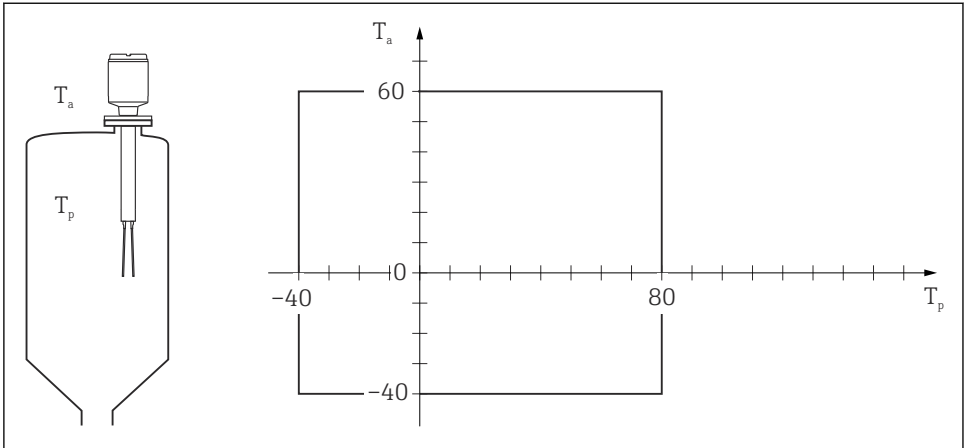

A0027400

 3

 T_a Ambient temperature in °C

 T_p Process temperature in °C

Device type	Type of protection	Ambient temperature T_a (ambient): enclosure <i>Basic specification, Position 6</i>	Process temperature T_p (process)
FTM52	Ex db [ia Ga] IIC T6 Ga/Gb Ex db [ia] IIC T6 Gb	$-40\text{ °C} \leq T_a \leq +60\text{ °C}$	$-40\text{ °C} \leq T_p \leq +80\text{ °C}$

Version with separate enclosure

Device type *FTM50, FTM51*

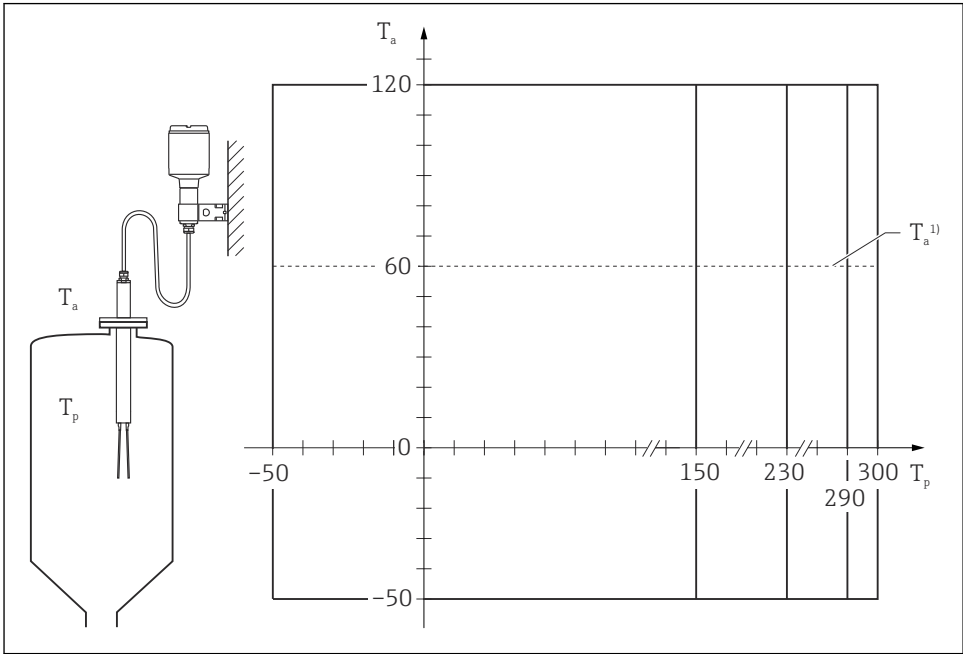

A0027402

4

- T_a Ambient temperature in °C
- T_p Process temperature in °C
- 1 T_a at enclosure: Restriction to 60 °C

Device type		Type of protection	Ambient temperature T_a (ambient): enclosure <i>Basic specification, Position 6</i>	Process temperature T_p (process)
FTM50	Enclosure	Ex db IIC T6 Gb	$-50\text{ °C} \leq T_a \leq +60\text{ °C}$	$-50\text{ °C} \leq T_p \leq +150\text{ °C}$
	Sensor	Ex ia IIC T6...T1 Ga/Gb Ex ia IIC T6...T3 Gb	$-50\text{ °C} \leq T_a \leq +120\text{ °C}$	$-50\text{ °C} \leq T_p \leq +230\text{ °C}$ $-50\text{ °C} \leq T_p \leq +290\text{ °C}$ $-50\text{ °C} \leq T_p \leq +300\text{ °C}$

Device type		Type of protection	Ambient temperature T_a (ambient): enclosure <i>Basic specification, Position 6</i>	Process temperature T_p (process)
FTM51	Enclosure	Ex db [ia Ga] IIC T6 Gb Ex db [ia IIIC Da] IIC T6 Gb	$-50\text{ °C} \leq T_a \leq +60\text{ °C}$	$-50\text{ °C} \leq T_p \leq +150\text{ °C}$
	Sensor	Ex ia IIC T6...T1 Ga/Gb Ex ia IIC T6...T3 Gb	$-50\text{ °C} \leq T_a \leq +120\text{ °C}$	$-50\text{ °C} \leq T_p \leq +230\text{ °C}$ $-50\text{ °C} \leq T_p \leq +290\text{ °C}$ $-50\text{ °C} \leq T_p \leq +300\text{ °C}$

Device type FTM52

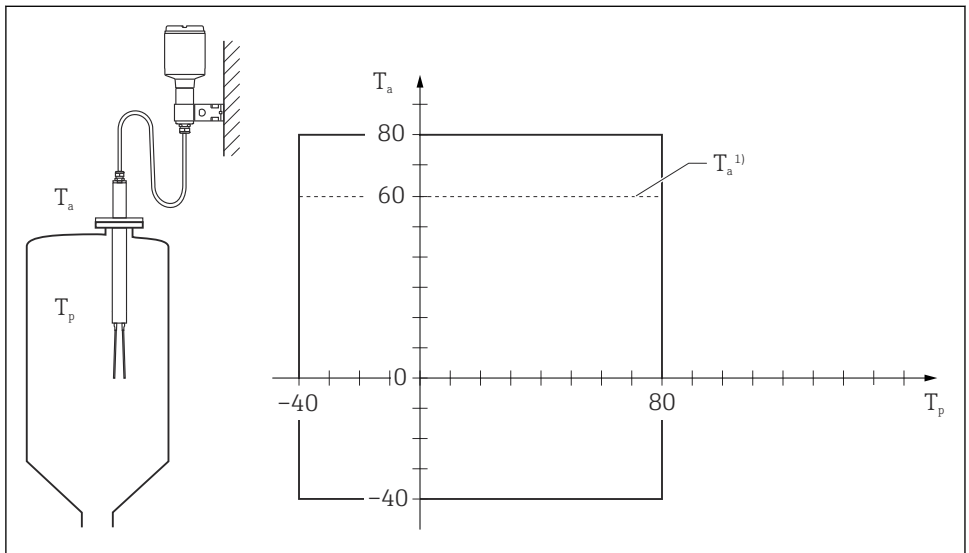

A0027403

5

- T_a Ambient temperature in °C
- T_p Process temperature in °C
- 1 T_a at enclosure: Restriction to 60 °C

Device type		Type of protection	Ambient temperature T_a (ambient): enclosure <i>Basic specification, Position 6</i>	Process temperature T_p (process)
FTM52	Enclosure	Ex db [ia Ga] IIC T6 Gb Ex db [ia IIIC Da] IIC T6 Gb	$-40\text{ °C} \leq T_a \leq +60\text{ °C}$	$-40\text{ °C} \leq T_p \leq +80\text{ °C}$
	Sensor	Ex ia IIC T6 Ga/Gb Ex ia IIC T6 Gb	$-40\text{ °C} \leq T_a \leq +80\text{ °C}$	

High-temperature version

Device type FTM50, FTM51

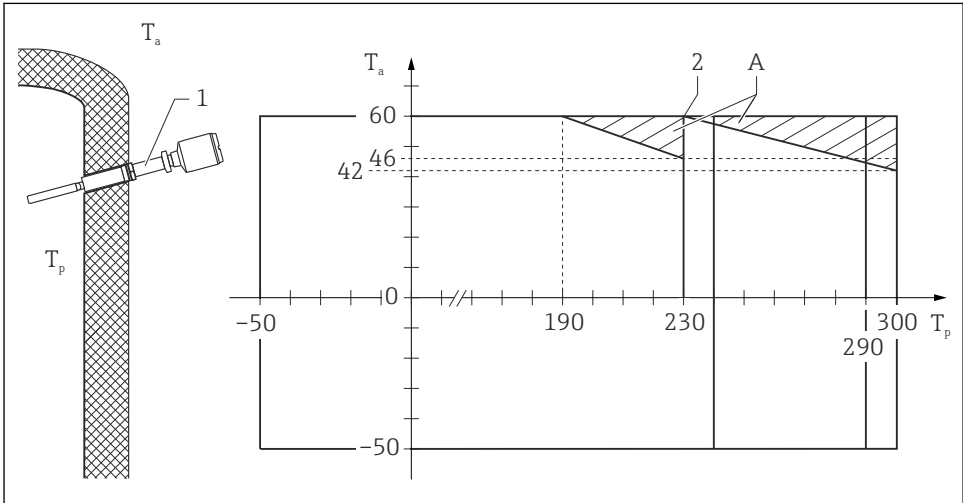

A0027401

6

T_a Ambient temperature in °C

T_p Process temperature in °C

A Additionally utilizable temperature range when using the temperature spacer outside the insulation

1 Temperature spacer outside the insulation

2 Antistick coating possible up to max. 230 °C

Application in dust

Device type	Basic specification, Position	Max. surface temperature	Process temperature T_p (process): sensor	Ambient temperature range
FTM50 FTM51	11 = D, E	160 °C	-50 to +150 °C	-40 to +60 °C
FTM50 FTM51	11 = J, K	240 °C	-50 to +230 °C	-40 to +60 °C
FTM50 FTM51	11 = F, H	290 °C	-50 to +280 °C	-40 to +60 °C
FTM50 FTM51	11 = Y	310 °C	-50 to +300 °C	-40 to +60 °C
FTM52		90 °C	-40 to +80 °C	-40 to +60 °C

Description notes

1st column: Device type

2nd column: Basic specification, Position 7 or 11

3rd column: Relay current

Column P1 to P5: Position (temperature value) on the axes of the derating

- T_a : Ambient temperature in °C
- T_p : Process temperature in °C

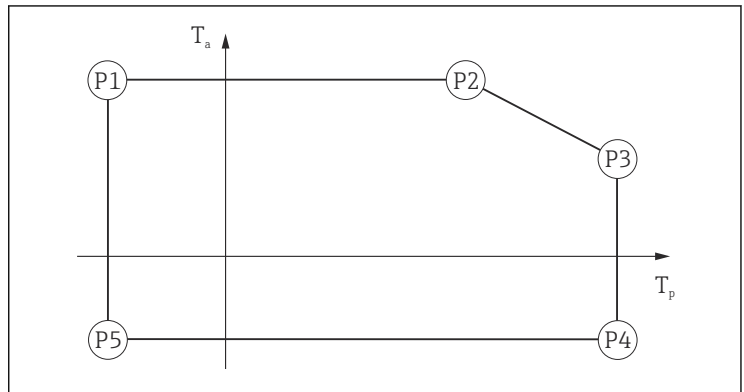

A0033052

Basic specification, Position 8 = H

with Basic specification, Position 6 = 1

			P1		P2		P3		P4		P5	
			T _p	T _a	T _p	T _a	T _p	T _a	T _p	T _a	T _p	T _a
FTM50 FTM51	7 = A	180 mA	-50	60	60	60	150	40	150	-50	-50	-50
		350 mA	-50	50	60	50	150	30	150	-50	-50	-50
FTM50 FTM51	11 = D, E	180 mA	-50	60	75	60	150	55	150	-50	-50	-50
		350 mA	-50	50	80	50	150	45	150	-50	-50	-50
FTM50 FTM51	11 = J, K	180 mA	-50	60	75	60	230	50	230	-50	-50	-50
		350 mA	-50	50	90	50	230	40	230	-50	-50	-50
FTM50 FTM51	11 = F, H	180 mA	-50	60	85	60	280	50	280	-50	-50	-50
		350 mA	-50	50	105	50	280	40	280	-50	-50	-50
FTM50 FTM51	11 = Y	180 mA	-50	60	85	60	300	50	300	-50	-50	-50
		350 mA	-50	50	105	50	300	40	300	-50	-50	-50
FTM52		180 mA	-40	60	60	60	80	55	80	-40	-40	-40
		350 mA	-40	50	60	50	80	45	80	-40	-40	-40

with Basic specification, Position 6 = 2

			P1		P2		P3		P4		P5	
			T _p	T _a	T _p	T _a	T _p	T _a	T _p	T _a	T _p	T _a
FTM50 FTM51	7 = A		-50	60	80	60	150	45	150	-50	-50	-50
FTM50 FTM51	11 = D, E		-50	60	130	60	150	55	150	-50	-50	-50
FTM50 FTM51	11 = J, K		-50	60	145	60	230	55	230	-50	-50	-50
FTM50 FTM51	11 = F, H		-50	60	175	60	280	55	280	-50	-50	-50
FTM50 FTM51	11 = Y		-50	60	175	60	300	55	300	-50	-50	-50
FTM52			-40	60	80	60	80	60	80	-40	-40	-40

with Basic specification, Position 6 = 4

			P1		P2		P3		P4		P5	
			T _p	T _a	T _p	T _a	T _p	T _a	T _p	T _a	T _p	T _a
FTM50 FTM51	7 = A	2 A	-50	60	60	60	150	40	150	-50	-50	-50
		4 A	-50	50	60	50	150	30	150	-50	-50	-50
		6 A	-50	40	60	40	60	40	60	-50	-50	-50
FTM50 FTM51	11 = D, E	2 A	-50	60	75	60	150	55	150	-50	-50	-50
		4 A	-50	50	80	50	150	45	150	-50	-50	-50
		6 A	-50	40	110	40	150	35	150	-50	-50	-50
FTM50 FTM51	11 = J, K	2 A	-50	60	75	60	230	50	230	-50	-50	-50
		4 A	-50	50	90	50	230	40	230	-50	-50	-50
		6 A	-50	40	125	40	230	35	230	-50	-50	-50
FTM50 FTM51	11 = F, H	2 A	-50	60	85	60	280	50	280	-50	-50	-50
		4 A	-50	50	105	50	280	40	280	-50	-50	-50
		6 A	-50	40	155	40	280	35	280	-50	-50	-50
FTM50 FTM51	11 = Y	2 A	-50	60	85	60	300	50	300	-50	-50	-50
		4 A	-50	50	105	50	300	40	300	-50	-50	-50
		6 A	-50	40	155	40	300	35	300	-50	-50	-50
FTM52		2 A	-40	60	60	60	80	55	80	-40	-40	-40
		4 A	-40	50	60	50	80	45	80	-40	-40	-40
		6 A	-40	45	65	45	80	35	50	-40	-40	-40

with Basic specification, Position 6 = 5

		P1		P2		P3		P4		P5	
		T _p	T _a	T _p	T _a	T _p	T _a	T _p	T _a	T _p	T _a
FTM50 FTM51	7 = A	-50	60	75	60	150	40	150	-50	-50	-50
FTM50 FTM51	11 = D, E	-50	60	110	60	150	55	150	-50	-50	-50
FTM50 FTM51	11 = J, K	-50	60	125	60	230	55	230	-50	-50	-50
FTM50 FTM51	11 = F, H	-50	60	145	60	280	55	280	-50	-50	-50
FTM50 FTM51	11 = Y	-50	60	145	60	300	55	300	-50	-50	-50
FTM52		-40	60	75	60	80	55	80	-40	-40	-40

*Basic specification, Position 8 = 5, 6**with Basic specification, Position 6 = 1*

			P1		P2		P3		P4		P5	
			T _p	T _a	T _p	T _a	T _p	T _a	T _p	T _a	T _p	T _a
FTM50 FTM51	7 = A	180 mA	-50	60	60	60	150	25	150	-50	-50	-50
		350 mA	-50	50	55	50	85	40	85	-50	-50	-50
FTM50 FTM51	11 = D, E	180 mA	-50	60	70	60	150	50	150	-50	-50	-50
		350 mA	-50	50	75	50	150	40	150	-50	-50	-50
FTM50 FTM51	11 = J, K	180 mA	-50	60	75	60	230	50	230	-50	-50	-50
		350 mA	-50	50	85	50	230	40	230	-50	-50	-50
FTM50 FTM51	11 = F, H	180 mA	-50	60	80	60	280	50	280	-50	-50	-50
		350 mA	-50	50	95	50	280	40	280	-50	-50	-50
FTM50 FTM51	11 = Y	180 mA	-50	60	80	60	300	50	300	-50	-50	-50
		350 mA	-50	50	95	50	300	40	300	-50	-50	-50
FTM52		180 mA	-40	60	60	60	80	50	80	-40	-40	-40
		350 mA	-40	50	55	50	80	40	80	-40	-40	-40

with Basic specification, Position 6 = 2

			P1		P2		P3		P4		P5	
			T _p	T _a	T _p	T _a	T _p	T _a	T _p	T _a	T _p	T _a
FTM50 FTM51	7 = A		-50	60	70	60	150	30	150	-50	-50	-50
FTM50 FTM51	11 = D, E		-50	60	115	60	150	55	150	-50	-50	-50
FTM50 FTM51	11 = J, K		-50	60	135	60	230	55	230	-50	-50	-50
FTM50 FTM51	11 = F, H		-50	60	155	60	280	50	280	-50	-50	-50
FTM50 FTM51	11 = Y		-50	60	155	60	300	50	300	-50	-50	-50
FTM52			-40	60	70	60	80	55	80	-40	-40	-40

with Basic specification, Position 6 = 4

			P1		P2		P3		P4		P5	
			T _p	T _a	T _p	T _a	T _p	T _a	T _p	T _a	T _p	T _a
FTM50 FTM51	7 = A	2 A	-50	50	50	50	75	40	75	-50	-50	-50
		4 A	-50	45	55	45	65	40	65	-50	-50	-50
		6 A	-50	40	50	40	50	40	50	-50	-50	-50
FTM50 FTM51	11 = D, E	2 A	-50	50	60	40	150	40	150	-50	-50	-50
		4 A	-50	45	90	45	150	40	150	-50	-50	-50
		6 A	-50	40	85	40	150	30	150	-50	-50	-50
FTM50 FTM51	11 = J, K	2 A	-50	50	65	50	230	40	230	-50	-50	-50
		4 A	-50	45	110	45	230	35	230	-50	-50	-50
		6 A	-50	40	105	40	230	30	230	-50	-50	-50
FTM50 FTM51	11 = F, H	2 A	-50	50	75	50	280	40	280	-50	-50	-50
		4 A	-50	45	140	45	280	35	280	-50	-50	-50
		6 A	-50	40	135	40	280	30	280	-50	-50	-50
FTM50 FTM51	11 = Y	2 A	-50	50	75	50	300	40	300	-50	-50	-50
		4 A	-50	45	140	45	300	35	300	-50	-50	-50
		6 A	-50	40	135	40	300	30	300	-50	-50	-50
FTM52		2 A	-40	50	50	50	80	35	80	-40	-40	-40
		4 A	-40	45	50	45	80	35	80	-40	-40	-40
		6 A	-40	40	50	40	50	40	50	-40	-40	-40

with Basic specification, Position 6 = 5

			P1		P2		P3		P4		P5	
			T _p	T _a	T _p	T _a	T _p	T _a	T _p	T _a	T _p	T _a
FTM50 FTM51	7 = A		-50	60	70	60	150	30	150	-50	-50	-50
FTM50 FTM51	11 = D, E		-50	60	100	60	150	55	150	-50	-50	-50
FTM50 FTM51	11 = J, K		-50	60	115	60	230	50	230	-50	-50	-50
FTM50 FTM51	11 = F, H		-50	60	130	60	280	50	280	-50	-50	-50
FTM50 FTM51	11 = Y		-50	60	130	60	300	50	300	-50	-50	-50
FTM52			-40	60	70	60	80	55	80	-40	-40	-40

Connection data

<i>Basic specification, Position 6</i>	Power supply	Output
1	19 to 253 V _{AC}	-
2	10 to 55 V _{DC}	-
4	19 to 253 V _{AC}	253 V _{AC} / 6 A 1500 VA / $\cos \varphi = 1$ 750 VA $\cos \varphi > 0.7$
	19 to 55 V _{DC}	30 V _{DC} / 4 A 125 V _{DC} / 0.2 A
5	11 to 35 V _{DC}	-



71580057

www.addresses.endress.com
