

Safety Instructions

Conductive Limit Detection

11362Z, 11363Z, 11375Z, 11961Z

II 1/2 G Ex ia IIC T6 Ga/Gb



Conductive Limit Detection

11362Z, 11363Z, 11375Z, 11961Z

Table of contents

Associated documentation	4
Supplementary documentation	4
Manufacturer's certificates	4
Manufacturer address	4
Other standards	4
Extended order code	5
Safety instructions: General	7
Safety instructions: Special conditions	8
Safety instructions: Installation	8
Safety instructions: Zone 0, Zone 1	10
Temperature tables	10

Associated documentation

This document is an integral part of the following Operating Instructions:

- TI00121F/00 (11362Z)
- TI00122F/00 (11363Z)
- TI00298F/00, KA00240F/00 (11375Z)
- TI00325F/00, KA00241F/00 (11961Z)

Supplementary documentation

Explosion-protection brochure: CP00021Z/11

The Explosion-protection brochure is available:

- In the download area of the Endress+Hauser website:
www.endress.com -> Downloads -> Brochures and Catalogs -> Text Search: CP00021Z
- On the CD for devices with CD-based documentation

Manufacturer's certificates**UK Declaration of Conformity**

Declaration Number:

UK_00434

The UK Declaration of Conformity is available:

In the download area of the Endress+Hauser website:

www.endress.com -> Downloads -> Declaration ->

Type: UKCA Declaration -> Product Code: ...

UKCA type-examination certificate

Certificate number:

CML 21UKEX2656X

List of applied standards: See UK Declaration of Conformity.

Manufacturer address

Endress+Hauser SE+Co. KG

Hauptstraße 1

79689 Maulburg, Germany

Address of the manufacturing plant: See nameplate.

Other standards

Among other things, the following standards shall be observed in their current version for proper installation:

- IEC/EN 60079-14: "Explosive atmospheres - Part 14: Electrical installations design, selection and erection"
- EN 1127-1: "Explosive atmospheres - Explosion prevention and protection - Part 1: Basic concepts and methodology"

Extended order code

The extended order code is indicated on the nameplate, which is affixed to the device in such a way that it is clearly visible. Additional information about the nameplate is provided in the associated Operating Instructions.

Structure of the extended order code

1136xZ, 11375Z, 11961Z	–	*****	+	A*B*C*D*E*F*G*..
<i>(Device type)</i>		<i>(Basic specifications)</i>		<i>(Optional specifications)</i>

* = Placeholder

At this position, an option (number or letter) selected from the specification is displayed instead of the placeholders.

Basic specifications

The features that are absolutely essential for the device (mandatory features) are specified in the basic specifications. The number of positions depends on the number of features available. The selected option of a feature can consist of several positions.

Optional specifications

The optional specifications describe additional features for the device (optional features). The number of positions depends on the number of features available. The features have a 2-digit structure to aid identification (e.g. JA). The first digit (ID) stands for the feature group and consists of a number or a letter (e.g. J = Test, Certificate). The second digit constitutes the value that stands for the feature within the group (e.g. A = 3.1 material (wetted parts), inspection certificate).

More detailed information about the device is provided in the following tables. These tables describe the individual positions and IDs in the extended order code which are relevant to hazardous locations.

Extended order code: Conductive Limit Detection

The following specifications reproduce an extract from the product structure and are used to assign:

- This documentation to the device (using the extended order code on the nameplate).
- The device options cited in the document.

Device type

11362Z, 11363Z

Basic specifications

Position 1 (Approval)		
Selected option		Description
1136xZ	4	UK Ex II 1/2 G Ex ia IIC T6 Ga/Gb, WHG
	5	UK Ex II 1/2 G Ex ia IIC T6 Ga/Gb

Position 2 (Application)		
Selected option		Description
1136xZ	1	FTW325
	8	Unspecified instrument

Position 10 or 11 (Electronics, Output)		
Selected option		Description
1136xZ	A ¹⁾	Not selected
	B	EW11Z; Line monitoring

1) Only in connection with Position 1 = 5

Optional specifications

No options specific to hazardous locations are available.



The following specifications reproduce an extract from the product structure and are used to assign:

- This documentation to the device (using the extended order code on the nameplate).
- The device options cited in the document.

Device type

11375Z, 11961Z

Basic specifications

Position 1 (Approval)		
Selected option		Description
11375Z	4	UK Ex II 1/2 G Ex ia IIC T6 Ga/Gb, WHG
	5	UK Ex II 1/2 G Ex ia IIC T6 Ga/Gb
11961Z	4	UK Ex II 1/2 G Ex ia IIC T6 Ga/Gb, WHG, XA Note safety instruction (XA) (electrostatic charging)!
	5	UK Ex II 1/2 G Ex ia IIC T6 Ga/Gb, XA Note safety instruction (XA) (electrostatic charging)!

Position 2 (Application)		
Selected option		Description
11961Z	R	For use with FTW325
	S	For use with FTC325
11375Z 11961Z	X	Unspecified instrument

Optional specifications

No options specific to hazardous locations are available.

Safety instructions:
General

- The device is intended to be used in explosive atmospheres as defined in the scope of IEC 60079-0 or equivalent national standards. If no potentially explosive atmospheres are present or if additional protective measures have been taken: The device may be operated according to the manufacturer's specifications.
- Staff must meet the following conditions for mounting, electrical installation, commissioning and maintenance of the device:
 - Be suitably qualified for their role and the tasks they perform
 - Be trained in explosion protection
 - Be familiar with national regulations
- Install the device according to the manufacturer's instructions and national regulations.
- Do not operate the device outside the specified electrical, thermal and mechanical parameters.
- Only use the device in media to which the wetted materials have sufficient durability.
- Avoid electrostatic charging:
 - Of plastic surfaces (e.g. enclosure, sensor element, special varnishing, attached additional plates, ..)
 - Of isolated capacities (e.g. isolated metallic plates)

Safety instructions:

Special conditions

- For light metal flanges or flange faces (e.g. titanium, zirconium), avoid sparks caused by impact and friction.
- Probes coated with a non-conductive material can be used in gases of Group IIC if avoiding electrostatic charging (e.g. through friction, cleaning, maintenance, strong medium flow). These probes are marked by the warning sign "Avoid Electrostatic Charge".
- To avoid electrostatic charging: Do not rub surfaces with a dry cloth.
- In the event of additional or alternative special varnishing on the enclosure or other metal parts or for adhesive plates:
 - Observe the danger of electrostatic charging and discharge.
 - Do not install in the vicinity of processes (≤ 0.5 m) generating strong electrostatic charges.

Device type 11362Z, 11363Z

Avoid sparks caused by impact and friction.

Safety instructions:
Installation

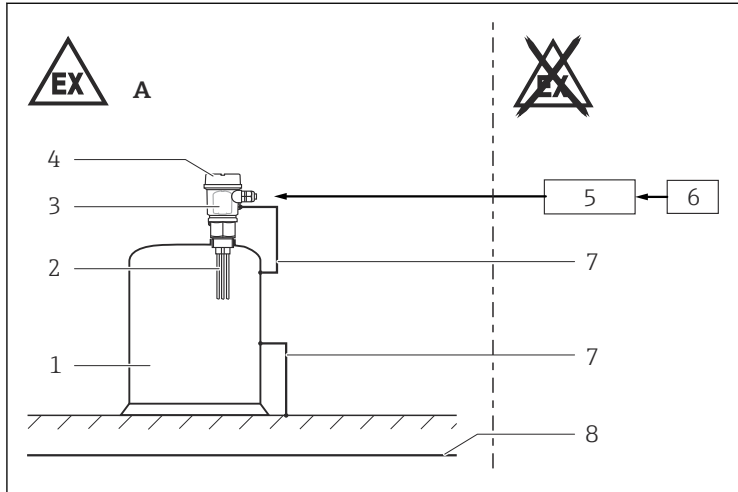

A0042810



- A Zone 1
 1 Tank; Zone 0
 2 11362Z, 11363Z, 11375Z, 11961Z
 3 Electronic insert
 4 Housing
 5 Certified associated apparatus
 6 Power supply
 7 Potential equalization line
 8 Potential equalization

- The probe is to remain mounted during all statutory pressure tests of the vessel.
- Install the device to exclude any mechanical damage or friction during the application. Pay particular attention to flow conditions and tank fittings.

Overvoltage protection

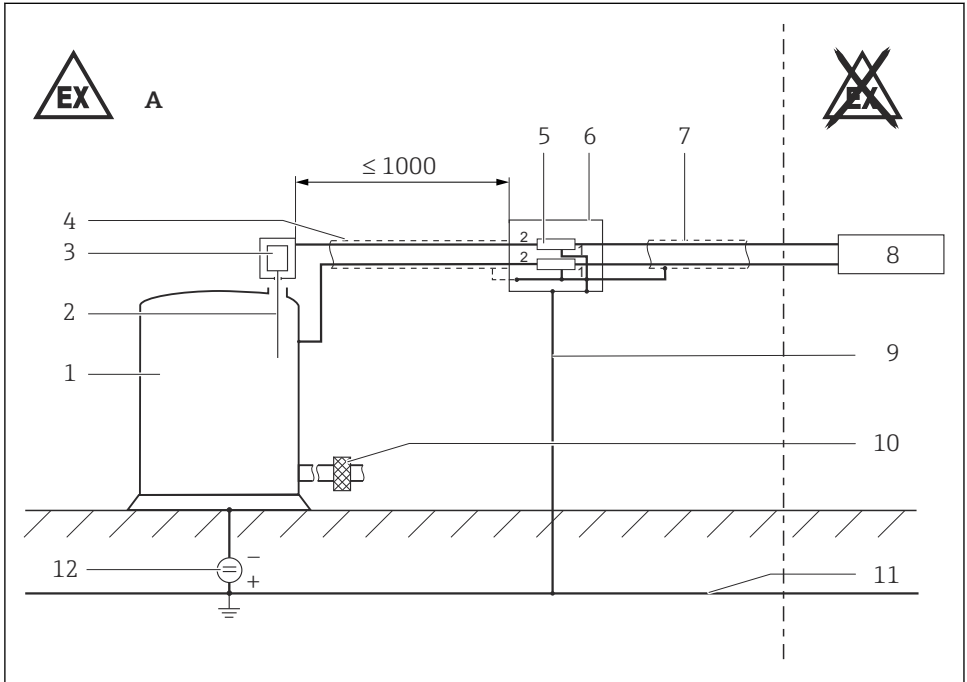

A0038919

2 Dimensions in mm

- A Zone 1, Zone 2
- B Zone 0
- 1 Tank
- 2 Probe
- 3 Electronic insert
- 4 e.g. metal hose, metal pipe
- 5 Overvoltage protection, e.g. HAW562
- 6 Grounding via top-hat rail or 51003750 metallic protective enclosure
- 7 Cable with screening or metal sheath
- 8 Certified associated apparatus
- 9 Potential equalization line $\geq 4 \text{ mm}^2 \text{ Cu}$
- 10 Insulator (optional)
- 11 Potential equalization
- 12 Cathodic protection (Object voltage)

- If an overvoltage protection against atmospheric over voltages is required: no other circuits may leave the enclosure during normal operation without additional measures.
- For installations which require overvoltage protection to comply with national regulations or standards, install the device using overvoltage protection (e.g. HAW56x from Endress+Hauser).
- Observe the safety instructions of the overvoltage protection.

**Safety instructions:
Zone 0, Zone 1**

- Version with zone separation: Zone separation realized by the process connections.
- Versions of process connection:
 - Thread
 - Flange
- Process connections with thread:
 - Thread pitch ≥ 0.7
 - Thread engagement ≥ 5 turns
 - Screw-in depth ≥ 8 mm
- Ensure gas-tight installation of the process connections.
- After mounting and connecting the probe, it is essential to ensure tightness at the process connection of IP67.
- Supplied gasket: Suitable for temperature ranges from -50 to $+200$ °C.
- It is the responsibility of the plant operator to ensure sealing in the vicinity of the process connection.

Temperature tables

Device type	Temperature class	Maximum fluid temperature
all with line monitoring	T6	Ambient temperature ≤ 70 °C
all	T6	≤ 85 °C
	T5	≤ 100 °C
	T4	≤ 135 °C
11961Z	T3	≤ 200 °C



71544591

www.addresses.endress.com
