

Installation Instructions

Kit COV81

For the maintenance of COS81D/E sensors

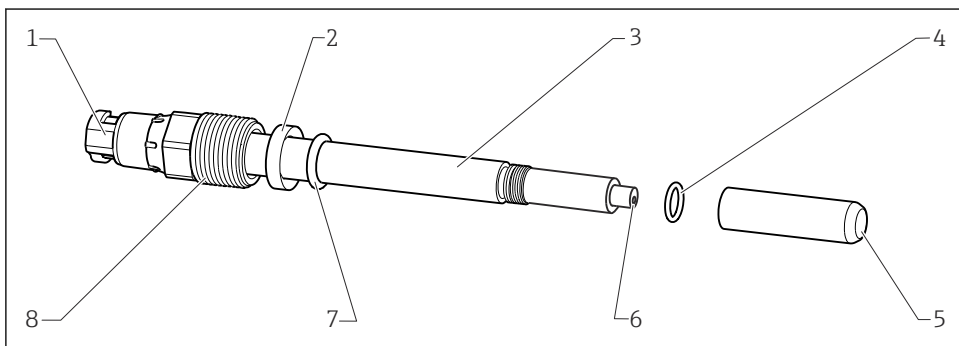

Table of contents

1	Overview of the sensor	3
2	Intended use	3
3	Authorized installation personnel	4
4	Safety instructions	4
5	Scope of delivery	5
6	Additional documentation	6
7	Replacement of spare parts	6
8	Disposal	11

1 Overview of the sensor

The exploded drawing shows the structure of the sensor COS81D/E.



A0027181

1 Structure of the COS81D/E sensor

- 1 Memosens plug-in head
- 2 Thrust collar
- 3 Sensor shaft
- 4 Sensor cap O-ring
- 5 Sensor cap
- 6 Optical waveguide with temperature sensor
- 7 Process seal
- 8 Process connection Pg 13.5

2 Intended use

- The components of the kits are to be used exclusively as maintenance parts for COS81D/E . Any other use is not permitted!
- Use only original parts from Endress+Hauser.
- In the W@M Device Viewer, check if the spare part is suitable for the existing device.

3 Authorized installation personnel

- Installation, commissioning, operation and maintenance of the measuring system may be carried out only by specially trained technical personnel.
- The technical personnel must be authorized by the plant operator to carry out the specified activities.
- The electrical connection may be performed only by an electrical technician.
- The technical personnel must have read and understood these Installation Instructions and must follow the instructions they contain.
- Faults at the measuring point may only be rectified by authorized and specially trained personnel.

 Repairs not described in the Operating Instructions provided must only be carried out directly at the manufacturer's site or by the service organization.

4 Safety instructions

CAUTION

Risk to health due to the removal of sensors from the process!

- ▶ When removing the sensor from the process, pay attention to the process pressure, process temperature and the aggressiveness or toxicity of the medium.

CAUTION

Risk to health due to contact with the process medium!

- ▶ Pay attention to the warning notices in the safety data sheets.
- ▶ Wear protective gloves, protective goggles and protective clothing, particularly when working with reagents, chemicals or process solutions.
- ▶ In case of contact with eyes or skin, rinse the affected area with plenty of water and then seek medical advice. Show the relevant safety data sheet to the physician.

Impact on the process

Before decommissioning an active device, the potential impact on the overall process must be taken into account! This applies in particular to the use of the switching contacts, analog signal outputs or the communication interface of the associated measuring device to control process variables. Coordinate service tasks with the operator!

Electrical safety

The COS81D/E sensor works exclusively with protective extra-low voltage. Therefore it does not pose an electrical hazard.

5 Scope of delivery

The COV81 service kit has a product structure. In terms of the quantity and version, the contents of a kit therefore depend on the version ordered (see the product structure below).

A kit always contains:

- Sensor cap
- Process seal and sensor cap O-ring
- Removal and O-ring mounting tool
- Cleaning cloth
- Manufacturer certificate
- Kit instructions

If required, the following parts must be added to the order code:

Certificates

COV81	Number of optical caps			
	A	1 piece		
Type of optical cap				
	C	c-shaped		
	U	u-shaped		
Material of sensor cap				
	A	Stainless steel		
	B	Titanium		
	C	Alloy C22		
Material of O-ring				
		1	EPDM	
		3	FFKM	
Material of process seal				
		1	FKM	
		3	FKM Ex	
+ options ← complete order code				

Options	
JA	Inspection certificate 3.1, EN10204 (material certificate, wetted parts)
KB	Surface finish measurement, Ra<0,38 µm, wetted metal parts, inspection certificate
JE	CoC AMSE BPE, Declaration
JG	Compliance with requirements derived from cGMP, Declaration
J1	EU Food Contact Materials (EC) 1935/2004, Declaration
J2	US Food Contact Materials FDA CFR 21, Declaration

J3	CN Food Contact Materials GB 4806, Declaration
LW	Pharma Certificate of Compliance



A0051095

2 Maintenance kit COV81



- 1 Sensor cap O-rings
- 2 Process seal
- 3 Cleaning cloth
- 4 Sensor cap
- 5 Removal and O-ring mounting tool

6 Additional documentation

Detailed information on the device can be found in the Operating Instructions for the sensor and in the other documentation available via:

- www.endress.com/device-viewer
- Smartphone / tablet: Endress+Hauser Operations App

7 Replacement of spare parts

 Sections 7.1 and 7.2 below describe the fundamental procedures for replacing individual spare parts. The individual steps are described in detail in the **Performing full maintenance** section →  8.

 Only original Endress+Hauser spare parts are permitted. Please ensure that the configuration of the maintenance kit is correct (e.g. choice of O-rings) to maintain the hygienic design of the sensor.

7.1 Replacing the process seal or sensor cap O-ring

The process seal and/or the sensor cap O-ring must be replaced in the event of mechanical damage.

1. Remove the sensor cap.
2. Clean the sensor shaft and optical waveguide.
3. Inspect the process seal and/or sensor cap O-ring for damage and replace if necessary.
4. Mount a new process seal or new sensor cap O-ring.
5. Screw on the sensor cap.

7.2 Replacing the sensor cap

The sensor cap is replaced without replacing the process seal and the sensor cap O-ring if the latter are not damaged or their replacement is not desired (however, it is advisable to replace the process seal and the sensor cap O-ring each time the sensor cap is replaced).

1. Remove the sensor cap.
2. Clean the sensor shaft and optical waveguide.
3. Perform a visual inspection of the new sensor cap.
4. Screw on the sensor cap.
5. Reset the counter.
6. Perform a calibration.

7.3 Performing full maintenance

- Observe the warnings in Section 4.

The following section describes the sensor maintenance procedure on a step-by-step basis. Depending on the necessary maintenance, not all steps are required. See Sections 7.1 - 7.2.

Removing the sensor cap

1. Remove the sensor from the process and clean it. A cleaning agent appropriate for the type of contamination should be used for this purpose.

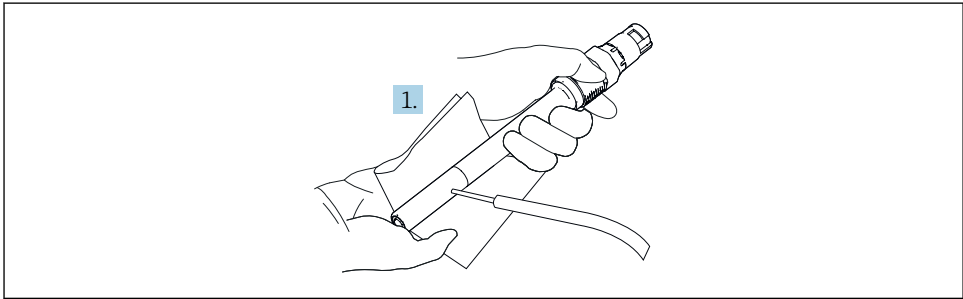

A0051612

2. Unscrew the sensor cap.

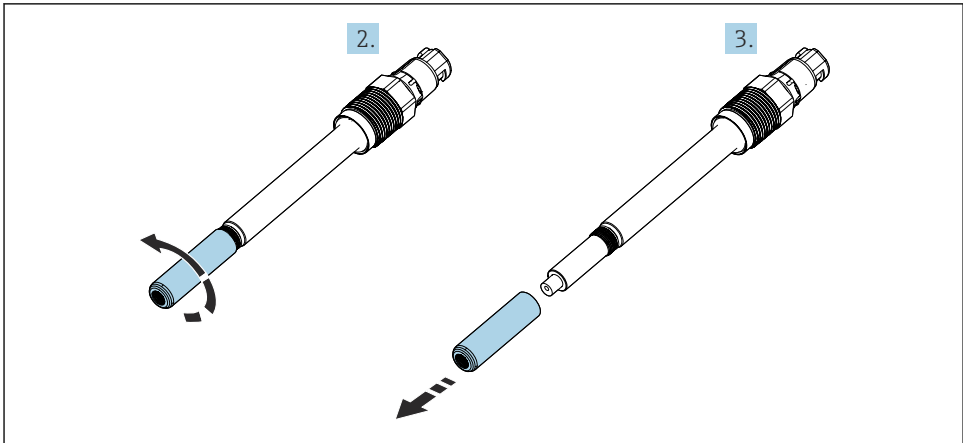

A0051360

3. Remove the sensor cap.

Cleaning the sensor shaft and optical waveguide

- Clean and dry the sensor shaft and optical waveguide.

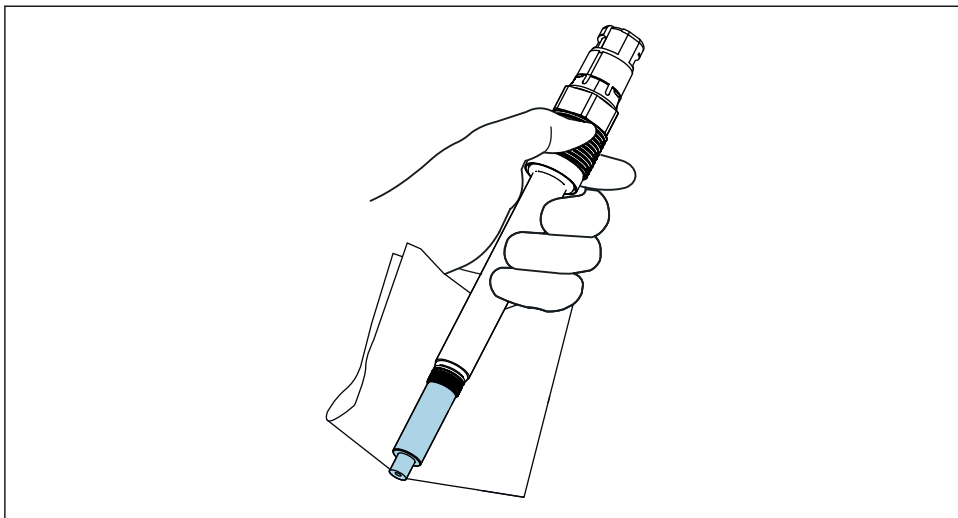

A0051094

i Dab the optical waveguide with the enclosed cleaning cloth. Do not wipe it!

Inspecting the process seal or sensor cap O-ring

► Check the process seal or sensor cap O-ring for damage. If in doubt, always replace it!

i To remove, do not use any sharp or pointed objects so that you do not damage the sensor.

Mounting the process seal or sensor cap O-ring

1. To mount the process seal and the O-ring on the sensor cap, fit the removal and O-ring mounting tool on the sensor.
2. Slide the process seal and the O-ring in succession over the removal and O-ring mounting tool and onto the sensor until they have reached their end position.

i Recommendation:

In SIP and CIP applications (sterilization in place, cleaning in place), the sensor cap O-ring should also be replaced each time the sensor cap is replaced.

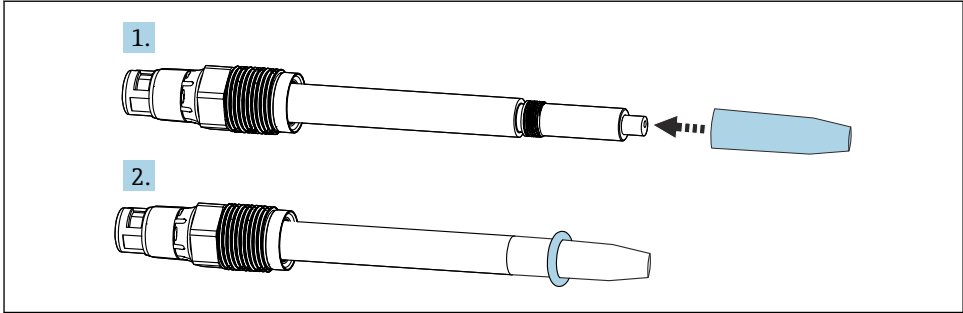

Visual inspection of new sensor cap

- Hold the sensor cap up against the light. Only the green homogeneous fluorescence layer should be visible inside the sensor cap.

Screwing on the sensor cap

1. Fit the sensor cap on the sensor head.
2. Screw the sensor cap onto the sensor shaft to the end stop so that a gap is no longer visible between the sensor cap and the sensor shaft.

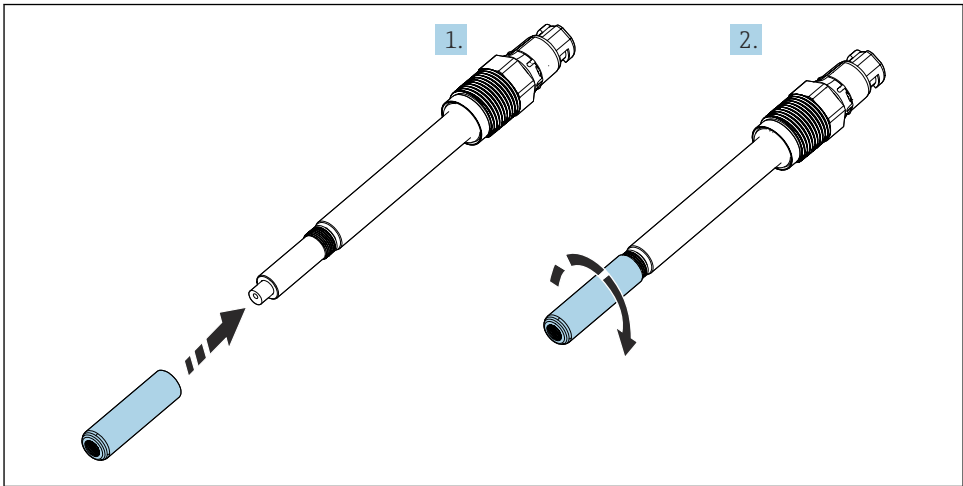

Resetting the counters

1. Enter the sensor maintenance with sensor cap changes in the transmitter.

 When the event is entered, the counters for the sensor cap are reset simultaneously in the transmitter. In addition, the calibration quality index is adapted to the new sensor cap after calibration in air and zero point calibration. Otherwise a maintenance message is generated.

 Warnings can also be configured for the counters to assist with sensor maintenance. The menu paths indicated refer to the Liquiline CM44x:
Menu/Calibration/Oxygen (opt.)/Change sensor cap

2. Then press the **Save** key to confirm the process.

Performing a calibration

1. Perform a calibration.
2. Put the measuring system back into operation.

 The calibration (point in oxygen and/or zero point calibration is possible) must be performed after every sensor maintenance!
Follow the Operating Instructions for the measuring device used.

8 Disposal

8.1 Sensors



If required by the Directive 2012/19/EU on waste electrical and electronic equipment (WEEE), the product is marked with the depicted symbol in order to minimize the disposal of WEEE as unsorted municipal waste. Do not dispose of products bearing this marking as unsorted municipal waste. Instead, return them to the manufacturer for disposal under the applicable conditions.



71596678

www.addresses.endress.com
