



# Special Documentation Cable gland M20 Ex d

for the Japanese market

## Overview

In case the protection type for hazardous protection is Ex d, Endress+Hauser offers explosion proof cable glands for the Japanese market.

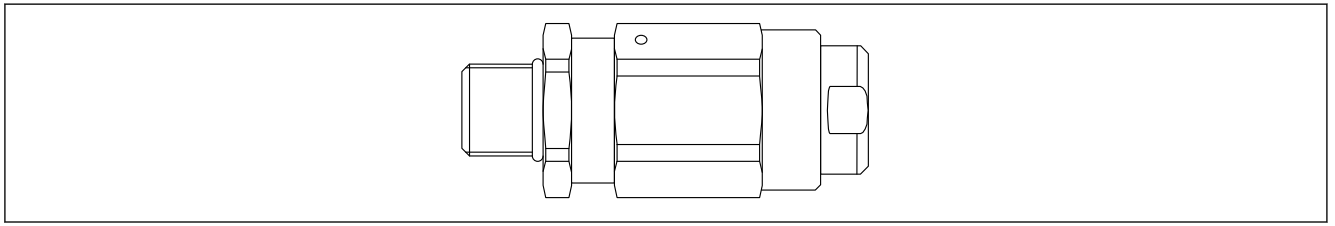

A0042252

## Order number

71471535

Cable gland M20×1.5 × G1/2, Ex d, brass

## Standard Specification

- Substance Material:  
Brass
- Surface Treatment:  
Nickel Electroplating
- Pressure Resisting Material:  
Ethylene Propylene Diene Rubber
- O-Ring Material:  
Ethylene Propylene Diene Rubber

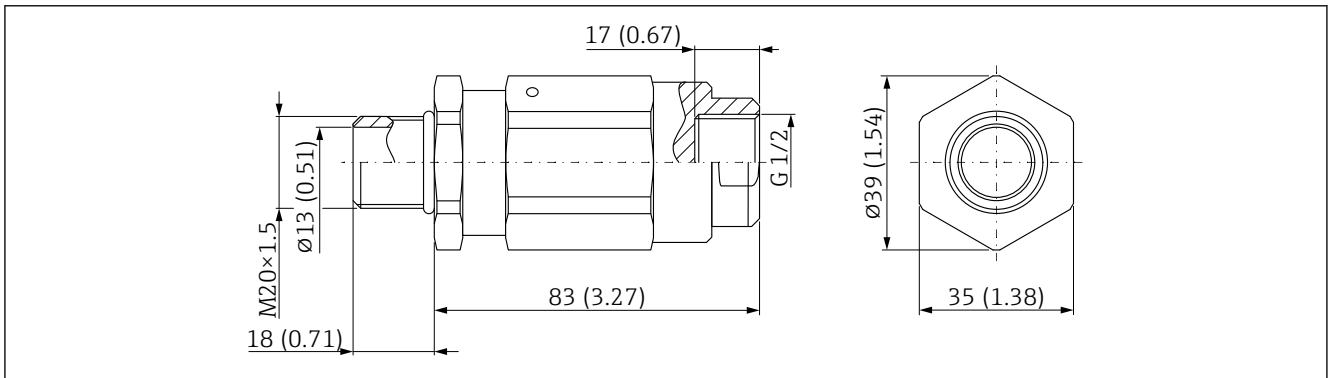

A0048552

1 Dimensions. Unit of measurement mm (in)

## Documentation

The following documentation supplies useful information what to observe and how to install the supplied third party Ex d cable gland.

This document is part of the Operating Instructions of the related instruments.

The related documentation is available in the Downloads of the Endress+Hauser website ([www.endress.com/downloads](http://www.endress.com/downloads)):



For an overview of the scope of the associated Technical Documentation, refer to the following:

- *W@M Device Viewer* ([www.endress.com/deviceviewer](http://www.endress.com/deviceviewer)): Enter the serial number from nameplate
- *Endress+Hauser Operations App*: Enter the serial number from the nameplate or scan the 2D matrix code on the nameplate

**Supplementary documentation**

**CP00021Z/11**

Explosion-protection brochure

**Supplier's certificates**

Certificate number:

IECEX DEK 18.0029

<https://www.iecex-certs.com/#/deliverables/CERT/45026/view>

**Equipment and systems covered by this certificate are as follows:**

Cable gland, type EXTC-\*\*\*\*, made of nickel plated brass steel or stainless steel is for use with effectively filled circular non-armoured cables

The cable gland can have different sealing rings making them suitable for the different cable diameter ranges.

For details about the type designation and technical data see Annex 1 to Report No. NL/DEK/ExTR18.0029/01.

**Ambient temperature range**

-20 to +75 °C



When you mount the cable gland to a measurement device you form an assembly. The allowable ambient temperature range of the assembly is determined by ambient temp limits of the cable gland and the measurement device. Please check name plate of the measurement device.

**Degree of protection**

IP66 per IEC 60079-0 and IEC 60529

**Addresses:**

**Manufacturer**

Shimada Electric Co.,Ltd  
2-29-6, Nakaikegami,  
Ohta-ku, Tokyo 146-0081  
Japan

**Supplier**

Endress+Hauser SE+Co. KG  
Hauptstraße 1  
79689 Maulburg  
Germany

**Related instruments**

Endress+Hauser recommends using the Shimada **EXTC-16\*\*** for Japanese Market for the following devices with electrical connection M20x1.5

**Liquiphant**

- FTL41-JC#####
- FTL51B-JC#####
- FTL51B-JD#####
- FTL62-JC#####
- FTL62-JD#####
- FTL63-JC#####
- FTL63-JD#####
- FTL64-JC#####
- FTL64-JD#####

**Gammapilot**

FMG50-JQ#####

**Cerabar**

- PMP51B-JF#####
- PMP71B-JF#####
- PMC51B-JF#####
- PMC71B-JF#####

**Deltabar**

- PMD55B-JF#####
- PMD75B-JF#####
- PMD78B-JF#####

**Levelflex**

- FMP51-JC#####
- FMP52-JC#####
- FMP54-JD#####
- FMP54-JE#####
- FMP55-JC#####
- FMP56-JC#####
- FMP57-JC#####

**Micropilot**

- FMR50-JJ#####
- FMR51-JC#####
- FMR51-JD#####
- FMR51-JE#####
- FMR52-JC#####
- FMR52-JF#####
- FMR53-JC#####
- FMR54-JC#####
- FMR54-JD#####
- FMR54-JE#####
- FMR57-JF#####
- FMR60-JC#####
- FMR62-JC#####
- FMR67-JC#####
- FMR60B-JC#####
- FMR62B-JC#####
- FMR63B-JC#####
- FMR66B-JC#####
- FMR67B-JC#####
- NMR81-JC#####
- NMR81-JE#####
- NMR84-JC#####

**Tankside Monitor**

- NRF81-JA#####

**Soliphant**

- FTM50-S#####
- FTM51-S#####

**Safety instructions****General**

- Staff must meet the following conditions for mounting, electrical installation, commissioning and maintenance of the device:
  - Be suitably qualified for their role and the tasks they perform
  - Be trained in explosion protection
  - Be familiar with national regulations
- Install the device according to the manufacturer's instructions and national regulations
- Do not operate the device outside the specified electrical, thermal and mechanical parameters
- Only use the device in media to which the wetted materials have sufficient durability
- Refer to the temperature tables for the relationship between the permitted ambient temperature for the sensor and/or transmitter and accessories, depending on the range of application and the temperature class

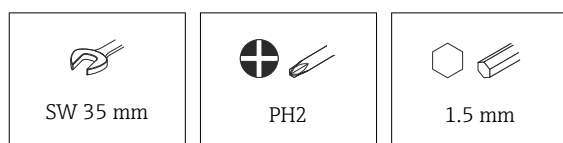
**Tools list**

## Mounting

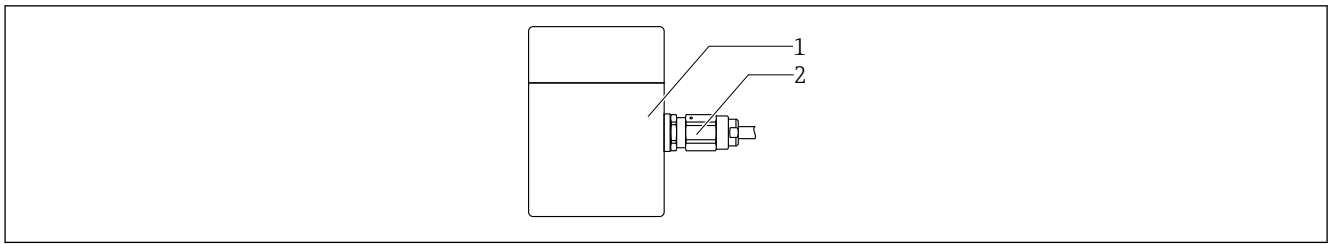

A0039525

- 1 Housing/terminal box with M20 thread
- 2 Ex d cable gland

### Mounting the cable gland

1. Tighten the cable gland (2) into thread hole of terminal box (1) using tightening tool with a torque of 4 Nm. Then tighten the lock screw (3) using a hexagon wrench (nominal 1.5).

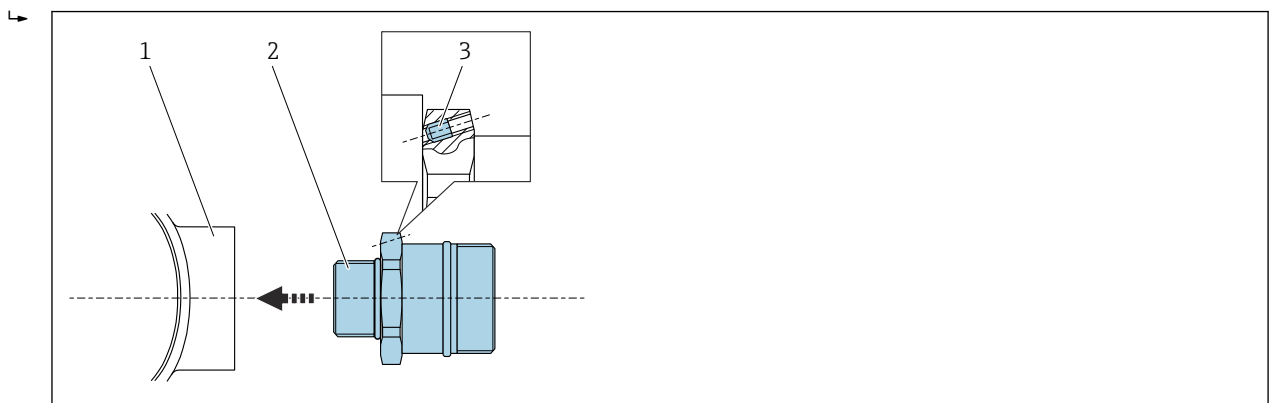

A0037072

- 1 Terminal box
- 2 Cable gland (M20×1.5)
- 3 Lock screw

2. Pass the cable (11) through the individual parts.

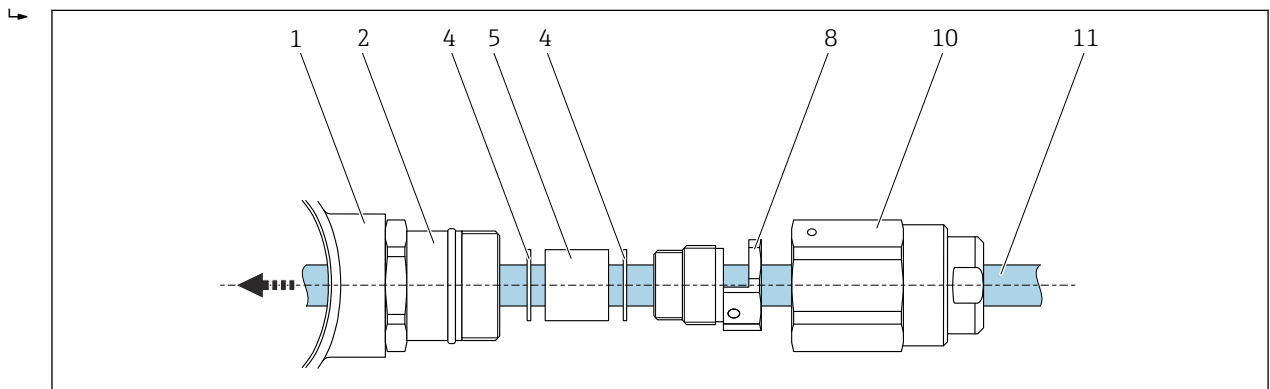

A0037073

- 1 Terminal box
- 2 Cable gland
- 4 Washer
- 5 Sealing ring
- 8 Packing gland
- 10 Union nut/B. coupling
- 11 Cable

3. Screw the packing gland (8) into cable gland (2) using a wrench and tighten the sealing ring (5) with tightening torque 6 Nm.

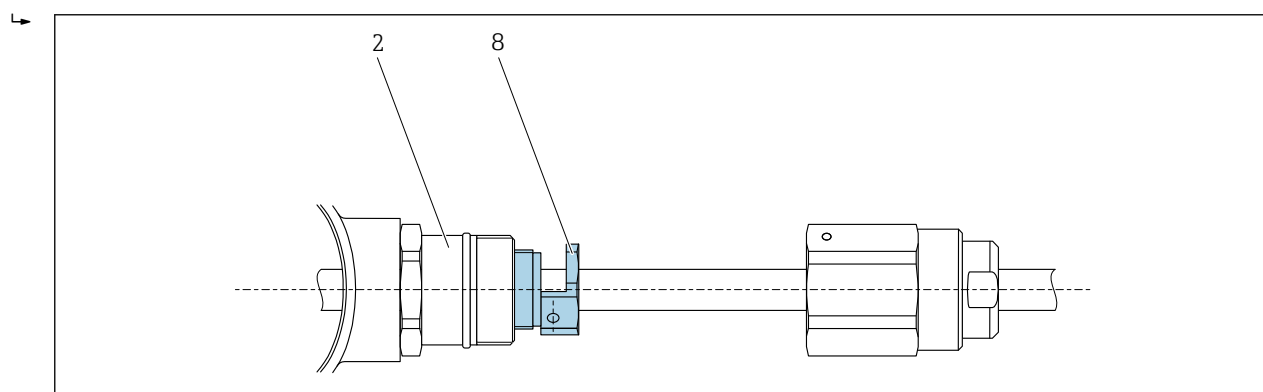

A0037075

- 2 Cable gland  
8 Packing gland

Cable diameter (in mm)		Inner diameter of the sealing ring (in mm)	Inner diameter of the washer (in mm)
Minimum	Maximum		
φ 6	φ 8	φ 8	φ 10.5
φ 8	φ 10.0	φ 10.0	
φ 10.0	φ 12.0	φ 12.0	φ 13.0

4. Secure the cable (11) firmly with clamp (6) and set screws (7). In this case the tightening torque is 1 Nm.

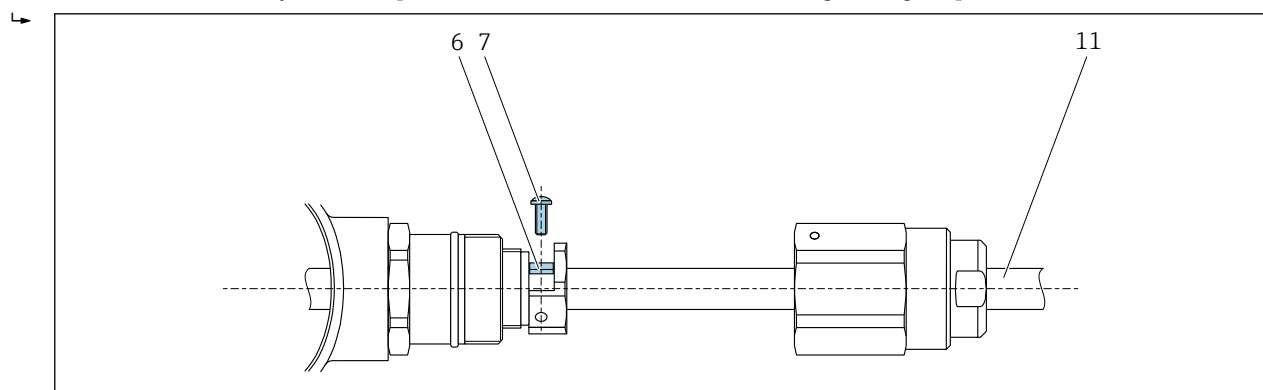

A0037082

- 6 Clamp  
7 Set screw  
11 Cable

5. Screw the union nut/B. coupling (10) onto cable gland (2) and tighten the lock screw (9) using a hexagon wrench (nominal 1.5).

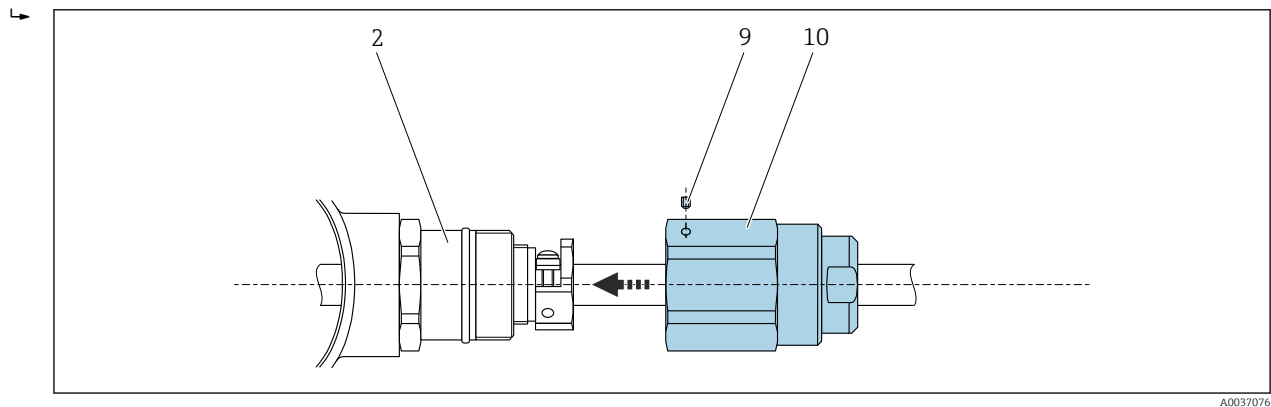

- 2 Cable gland  
9 Lock screw  
10 Union nut/B. coupling (G 1/2)