



Brief Operating Instructions

RLN22

1- or 2-channel NAMUR isolating amplifier 24 V_{DC} with relay signal output

These Brief Operating Instructions are not a substitute for the Operating Instructions pertaining to the device. Detailed information is provided in the Operating Instructions and other documentation.

Available for all device versions via:

- Internet: www.endress.com/deviceviewer
- Smartphone/tablet: Endress+Hauser Operations app

Basic safety instructions

Requirements for the personnel

The personnel must fulfill the following requirements for its tasks:

- ▶ Trained, qualified specialists must have a relevant qualification for this specific function and task.
- ▶ Are authorized by the plant owner/operator.
- ▶ Are familiar with federal/national regulations.
- ▶ Before starting work, read and understand the instructions in the manual and supplementary documentation as well as the certificates (depending on the application).
- ▶ Follow instructions and comply with basic conditions.

Intended use

The NAMUR isolating amplifier is designed for the operation of proximity switches, floating contacts and contacts with a resistive circuit. A relay is available as the signal output. The device is designed for installation on DIN rails in accordance with IEC 60715.

Product liability: The manufacturer does not accept any responsibility for damage that results from non-designated use and from failure to comply with the instructions in this manual.

Operational safety

Risk of injury!

- ▶ Operate the device only if it is in proper technical condition, free from errors and faults.
- ▶ The operator is responsible for interference-free operation of the device.

Hazardous area

To eliminate danger to persons or the facility when the device is used in the hazardous area (e.g. explosion protection):

- ▶ Check the nameplate to verify if the device ordered can be put to its intended use in the hazardous area.

- ▶ Observe the specifications in the separate supplementary documentation that is an integral part of these instructions.

Product safety

This device is designed in accordance with good engineering practice to meet state-of-the-art safety requirements, has been tested, and left the factory in a condition in which it is safe to operate.

Installation instructions

- The device's IP20 degree of protection is intended for a clean and dry environment.
- Do not expose the device to mechanical and/or thermal stress that exceeds the specified limits.
- The device is intended for installation in a cabinet or similar housing. The device may only be operated as an installed device. The cabinet must meet the fire protection housing requirements according to safety standard UL/IEC 61010-1 and provide adequate protection against electric shock or burns.
- To protect against mechanical or electrical damage, the device must be installed in an appropriate housing with a suitable degree of protection according to IEC/EN 60529.
- The device fulfills the EMC regulations for the industrial sector (EMC Class A). It can cause electrical interference if used in residential environments.

Incoming acceptance and product identification

Incoming acceptance

Check the following during incoming acceptance:

- Are the order codes on the delivery note and the product sticker identical?
- Are the goods undamaged?
- Do the data on the nameplate match the ordering information on the delivery note?



If one of these conditions is not met, please contact the manufacturer's sales office.

Product identification



The following options are available for identification of the device:

- Nameplate specifications
- Extended order code with breakdown of the device features on the delivery note

Name and address of manufacturer

Name of manufacturer:	Endress+Hauser Wetzlar GmbH + Co. KG
Address of manufacturer:	Obere Wank 1, D-87484 Nesselwang
Model/type reference:	RLN22

Certificates and approvals

-  For certificates and approvals valid for the device: see the data on the nameplate
-  Approval-related data and documents: www.endress.com/deviceviewer → (enter the serial number)

Functional safety

A SIL version of the device is optionally available. It can be used in safety equipment in accordance with IEC 61508 up to SIL 2 .

Mounting

Mounting requirements

Dimensions

Width (B) x length (L) x height (H) (with terminals): 12.5 mm (0.49 in) x 116 mm (4.57 in) x 107.5 mm (4.23 in)

Mounting location

The device is designed for installation on 35 mm (1.38 in) DIN rails in accordance with IEC 60715 (TH35). The device's housing provides basic insulation from neighboring devices for 300 Veff. If several devices are installed side by side, this must be taken into consideration and additional insulation must be provided if necessary. If the adjacent device also offers basic insulation, no additional insulation is required.

NOTICE

- ▶ When using in hazardous areas, the limit values of the certificates and approvals must be observed.

Important ambient conditions

Ambient temperature range	-40 to 60 °C (-40 to 140 °F)	Storage temperature	-40 to 80 °C (-40 to 176 °F)
Degree of protection	IP 20	Overvoltage category	II
Pollution degree	2	Humidity	10 to 95 % No condensation
Altitude	≤ 2 000 m (6 562 ft)		

Mounting the DIN rail bus connector

Electrical connection

Connecting requirements

A flat-blade screwdriver is required to establish an electrical connection to screw or push-in terminals.

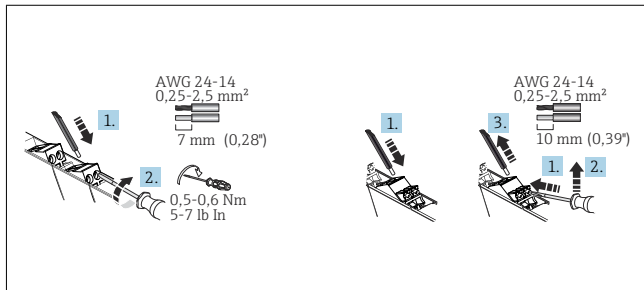

 2 Electrical connection using screw terminals (left) and push-in terminals (right)

CAUTION

Destruction of parts of the electronics

- ▶ Switch off the power supply before installing or connecting the device.

NOTICE

Destruction or malfunction of parts of the electronics



Please refer to Safety Manual FY01035K for the use of the device in safety instrumented systems according to IEC 61508.





Protection against modifications:

As it is not possible to disengage the operating elements (DIP switches), a lockable control cabinet is required for use in SIL applications. The cabinet must be locked by key. A normal electrical cabinet key does not suffice for this purpose.

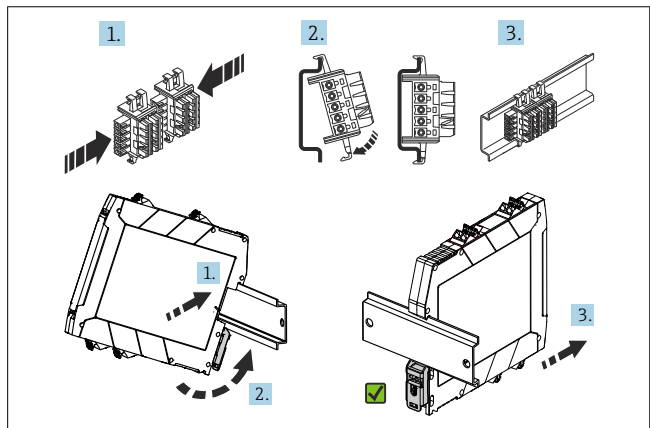

If using the DIN rail bus connector to the power supply, clip it onto the DIN rail BEFORE mounting the device. It is essential that you pay attention to the orientation of the module and the DIN rail bus connector: the snap-on clip should be at the bottom and the connector piece on the left.



 1 Mounting the DIN rail bus connector 12,5 mm (0,5 in) (top) and mounting on DIN rail (bottom)

Installing a DIN rail device

The device can be installed in any position (horizontal or vertical) on the DIN rail without lateral clearance from neighboring devices. No tools are required for installation. The use of end brackets (type WEW "35/1" or similar) on the DIN rail is recommended as an end support for the device.

- ▶  ESD - Electrostatic discharge. Protect the terminals from electrostatic discharge.

Special connection instructions

- Disconnecting units and auxiliary circuit protective systems with suitable AC or DC values must be provided in the building installation.
- A switch/power circuit breaker must be provided close to the device and clearly marked as a disconnecting unit for this device.
- An overcurrent protection unit (I≤16 A) must be provided in the installation.
- The voltages applied at the input and power supply are all extra-low voltages (ELV). Depending on the application, the switching voltage at the relay output can be a dangerous voltage (>30 V). Safe galvanic isolation to the other connections is provided for this scenario.

Important connection data

Power supply

Supply voltage	24 V _{DC} (-20% / +25%)	Current consumption at 24 V _{DC}	1-channel: ≤ 21 mA 2-channel: ≤ 35 mA
Supply current to the DIN rail bus connector	max. 400 mA	Power consumption at 24 V _{DC}	1-channel: < 0.65 W 2-channel: < 0.8 W
		Power loss at 24 V _{DC}	1-channel: < 0.65 W 2-channel: < 1 W

Input data (floating switch contacts with resistive coupling elements to connect NAMUR proximity switches (IEC/EN 60947-5-6))

Switch points	Blocking: < 1.2 mA Conducting: > 2.1 mA	Line fault detection (response range)	Open circuit: 0.05 mA < I _{IN} < 0.35 mA Short-circuit: 100 Ω < R _{sensor} < 360 Ω
Short-circuit current	~ 8 mA	Open-circuit voltage	~ 8 V _{DC}
Switching hysteresis	< 0.2 mA		

Relay output data

Contact type	1-channel: 1 changeover 2-channel: 1 NO contact per channel	Mechanical operating life	10 ⁷ switching cycles
Maximum switching voltage	250 V _{AC} (2 A) / 120 V _{DC} (0.2 A) / 30 V _{DC} (2 A)	Recommended minimum load	5 V / 10 mA
Maximum switching capacity	500 VA	Switching frequency (no load)	≤ 20 Hz

 For detailed technical data, see the Operating Instructions

Quick wiring guide

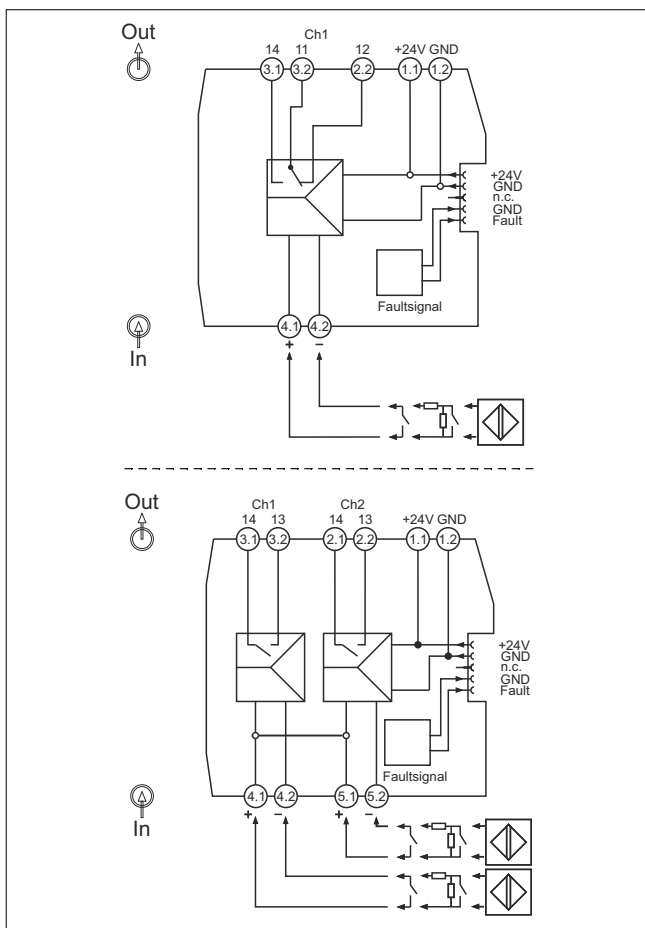

3 Terminal assignment of RLN22: 1-channel version (top), 2-channel version (bottom)

Connecting the supply voltage

Power can be supplied via terminals 1.1 and 1.2 or via the DIN rail bus connector.

Using the power and error message module to supply power

It is recommended to use the RNF22 power and error message module to provide the supply voltage to the DIN rail bus connector. An overall current of 3.75 A is possible with this option.

Supply to the DIN rail bus connector via terminals

Devices installed side by side can be powered via the terminals of the device up to a total current consumption of 400 mA. The connection is via the DIN rail bus connector. The installation of a 630 mA fuse (semi-delay or slow-blow) upstream is recommended.

NOTICE

The simultaneous use of terminals and DIN rail bus connectors to supply power is not permitted! The tapping of energy from the DIN rail bus connector for further distribution is not permitted.

- ▶ The supply voltage must never be connected directly to the DIN rail bus connector!

Display and operating elements

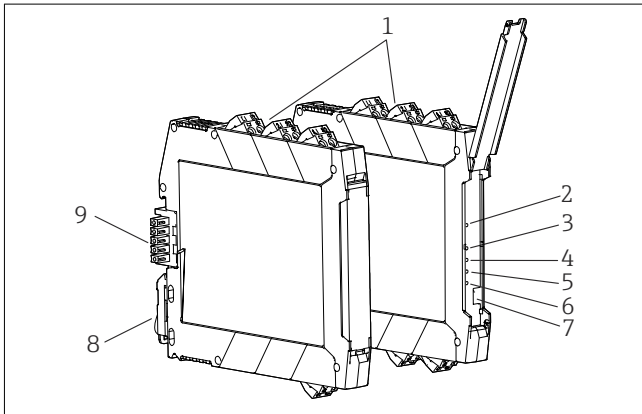

4 Display and operating elements

- 1 Plug-in screw or push-in terminal
- 2 Green LED "On", power supply
- 3 Red LED "LF1", line fault of sensor cable 1
- 4 Red LED "LF2", line fault of sensor cable 2 (option)
- 5 Yellow LED "OUT1", status relay 1
- 6 Yellow LED "OUT2", status relay 2 (option)
- 7 DIP switches 1 to 4
- 8 DIN rail clip for DIN rail mounting
- 9 DIN rail bus connector (optional)

Local operation

Hardware settings / configuration



Any device settings using the DIP switch must be made when the device is de-energized.

Maintenance

No special maintenance work is required for the device.



For details refer to the Operating Instructions

Direction of action

At the device, the direction of action (operating or closed circuit current behavior) can be selected and line fault detection can be enabled or disabled via DIP switches.

DIP switch 1 = channel 1; DIP switch 3 = channel 2 (optional)

All DIP switches are set to the "I" position when the device is delivered from the factory:

- I = normal phase (operating current behavior)
- II = inverse phase (closed circuit current behavior)

Line fault detection

DIP switch 2 = channel 1; DIP switch 4 = channel 2 (optional)

I = line fault detection switched off - **not permitted for safety-oriented applications!**

II = line fault detection switched on

If a line fault occurs, the relay is de-energized and the red LED "LF" flashes (NE 44).

An error message is transmitted to the power and error message module RNF22 via the DIN rail bus connector and forwarded as a group error message.

NOTICE

Error detection malfunctions

- ▶ For switch contacts with an open circuit, line fault detection (LF) must be disabled or the corresponding resistance circuit (1 k Ω /10 k Ω) must be provided directly at the contact. (See the "Quick wiring guide" and "Accessories" sections of the Operating Instructions)

Cleaning

A clean, dry cloth can be used to clean the device.