

Installation instructions to assure the IP rating of assembly

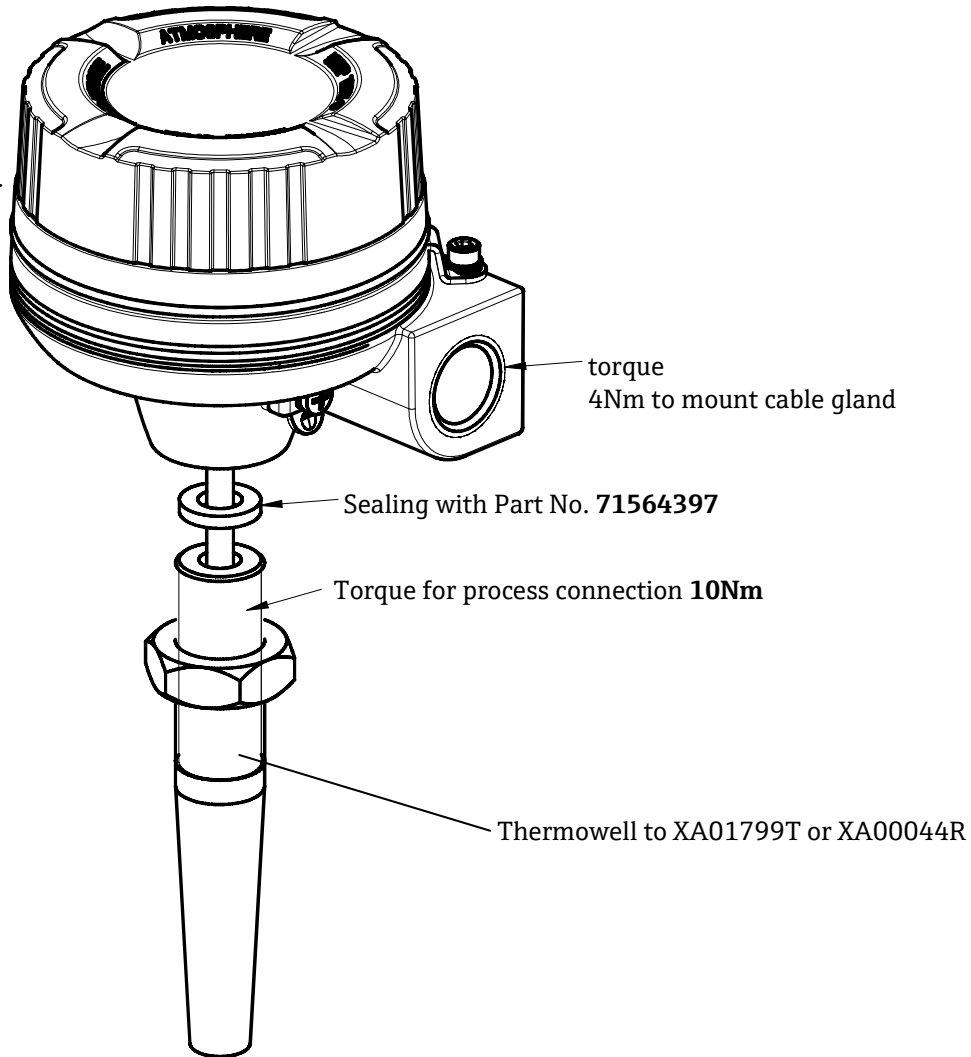

Installation instructions:

- Comply with the enclosed safety instruction XA01799T or XA00044R.
- Install the device according to the manufacturer's instructions and any other valid standards and regulations (e.g. IEC 60079-14).

⚠ Warning!

For assure that the temperature assembly has a degree of protection of at least IP6X the specified torque of 10Nm for tightening the thermowell shall be applied.

| | | | | | | | | | | | | | |
|------------|----------|-------------------|------------|-------------|-------------|-----------|---|----------------|--|----------------------------|------|--------------|---|
| Approved | Pfanzelt | Date (yyyy-mm-dd) | 2023-03-24 | Drawing No. | 10000013724 | Dwg. rev. | - | Revision no. | - | Revision date (yyyy-mm-dd) | Name | Material | - |
| Checked By | Pfanzelt | Date (yyyy-mm-dd) | 2023-03-23 | Unit | TM131 | Scale | - | Title | Installation instructions for separate thermowells XA03117T/09/EN/01.23-00 | | | | |
| Designed | Pfanzelt | Date (yyyy-mm-dd) | 2023-03-08 | Part No. | 71607425 | Format | - | Objekt version | | Serie | | Sheet 1 of 1 | |