

# Brief Operating Instructions

## **Rxn-10 Raman spectroscopic probe**





# Table of Contents

<b>1</b>	<b>About this document.....</b>	<b>4</b>
1.1	Disclaimer .....	4
1.2	Warnings .....	4
1.3	Symbols .....	5
1.4	U.S. export compliance.....	5
<b>2</b>	<b>Basic safety instructions .....</b>	<b>6</b>
2.1	Requirements for personnel.....	6
2.2	Designated use .....	6
2.3	Workplace safety.....	6
2.4	Operational safety.....	7
2.5	Laser safety.....	7
2.6	Service safety.....	8
2.7	Important safeguards.....	8
2.8	Product safety.....	8
<b>3</b>	<b>Product description .....</b>	<b>11</b>
3.1	The Rxn-10 probe.....	11
3.2	Rxn-10 probe and accessory optics.....	11
<b>4</b>	<b>Incoming product acceptance and product identification .....</b>	<b>13</b>
4.1	Incoming acceptance.....	13
4.2	Product identification .....	13
4.3	Scope of delivery.....	14
<b>5</b>	<b>Installation .....</b>	<b>15</b>
5.1	Probe and fiber optic connection .....	15
5.2	Installing optics .....	17
<b>6</b>	<b>Commissioning.....</b>	<b>24</b>
6.1	Receipt of probe.....	24
6.2	Probe calibration and verification.....	24
<b>7</b>	<b>Operation.....</b>	<b>26</b>
<b>8</b>	<b>Diagnostics and troubleshooting.....</b>	<b>27</b>

# 1 About this document

## 1.1 Disclaimer

These instructions are Brief Operating Instructions; they do not replace the Operating Instructions included in the scope of supply.

## 1.2 Warnings



Structure of Information	Meaning
<p> <b>WARNING</b></p> <p><b>Causes (/consequences)</b> Consequences of non-compliance (if applicable) ▶ Corrective action</p>	<p>This symbol alerts you to a dangerous situation. Failure to avoid the dangerous situation can result in a fatal or serious injury.</p>
<p> <b>CAUTION</b></p> <p><b>Causes (/consequences)</b> Consequences of non-compliance (if applicable) ▶ Corrective action</p>	<p>This symbol alerts you to a dangerous situation. Failure to avoid this situation can result in minor or more serious injuries.</p>
<p><b>NOTICE</b></p> <p><b>Cause/situation</b> Consequences of non-compliance (if applicable) ▶ Action/note</p>	<p>This symbol alerts you to situations which may result in damage to property.</p>

Table 1. Warnings

## 1.3 Symbols





Symbol	Description
	The Laser Radiation symbol is used to alert the user to the danger of exposure to hazardous visible and invisible laser radiation when using the Raman Rxn system.
	The High Voltage symbol that alerts people to the presence of electric potential large enough to cause injury or damage. In certain industries, high voltage refers to voltage above a certain threshold. Equipment and conductors that carry high voltage warrant special safety requirements and procedures.
	The WEEE symbol indicates that the product should not be discarded as unsorted waste but must be sent to separate collection facilities for recovery and recycling.
	The CE Marking indicates conformity with health, safety, and environmental protection standards for products sold within the European Economic Area (EEA).

Table 2. Symbols

## 1.4 U.S. export compliance

The policy of Endress+Hauser is in strict compliance with U.S. export control laws as detailed in the website of the [Bureau of Industry and Security](#) at the U.S. Department of Commerce.

## 2 Basic safety instructions

### 2.1 Requirements for personnel

- Installation, commissioning, operation, and maintenance of the measuring system may be carried out only by specially trained technical personnel.
- Technical personnel must be authorized by the plant operator to carry out the specified activities.
- Technical personnel must have read and understood these Operating Instructions and must follow the instructions contained herein.
- The facility must designate a laser safety officer who ensures staff are trained on all Class 3B laser operating and safety procedures.
- Faults at the measuring point may only be rectified by properly authorized and trained personnel. Repairs not described in this document must be carried out only at the manufacturer's site or by the service organization.

### 2.2 Designated use

The Rxn-10 Raman spectroscopic probe is designed for sample measurements in a laboratory, process development, or manufacturing (when part of a single-use probe system) environment. The probe head is compatible with a wide range of interchangeable, commercially available optics (immersion and non-contact) to meet the requirements of different applications.

Recommended applications include:

- **Chemical:** reaction monitoring, blending, catalyst monitoring, hydrocarbon speciation, process unit optimization
- **Polymer:** polymerization reaction monitoring, extrusion monitoring, polymer blending
- **Pharmaceutical:** active pharmaceutical ingredient reaction monitoring, crystallization
- **Biopharmaceutical:** cell culture and fermentation monitoring, optimization, control
- **Food and beverage:** zonal heterogeneity mapping of meats and fish

Use of the device for any purpose other than that described poses a threat to the safety of people and of the entire measuring system and invalidates any warranty.

### 2.3 Workplace safety

As the user, you are responsible for complying with the following safety conditions:

- Installation guidelines
- Local standards and regulations for electromagnetic compatibility

The product has been tested for electromagnetic compatibility in accordance with the applicable international standards for industrial applications.

The electromagnetic compatibility indicated applies only to a product that has been properly connected to the analyzer.

## 2.4 Operational safety

Before commissioning the entire measuring point:

- Verify that all connections are correct.
- Ensure that electro-optical cables are undamaged.
- Ensure fluid level is sufficient for probe/optics immersion (if applicable).
- Do not operate damaged products, and protect them against unintentional operation.
- Label damaged products as defective.

During operation:

- If faults cannot be rectified, products must be taken out of service and protected against unintentional operation.
- When working with laser devices, always follow all local laser safety protocols which may include the use of personal protective equipment and limiting device access to authorized users.

## 2.5 Laser safety

The Rxn-10 probe is connected to a Raman Rxn analyzer. The Raman Rxn analyzers use Class 3B lasers as defined in the following:

- [American National Standards Institute](#) (ANSI) Z136.1, American National Standard for Safe Use of Lasers
- [International Electrotechnical Commission](#) (IEC) 60825-1, Safety of Laser Products – Part 1

### WARNING

#### Laser radiation

- ▶ Avoid exposure to beam
- ▶ Class 3B laser product

### CAUTION

#### Laser beams can cause ignition of certain substances such as volatile organic compounds.

The two possible mechanisms for ignition are direct heating of the sample to a point causing ignition and the heating of a contaminant (such as dusts) to a critical point leading to ignition of the sample.

The laser configuration presents further safety concerns because the radiation is often not visible or barely visible. Always be aware of the initial direction and possible scattering paths of the laser. The use of laser glasses with OD3 or greater is highly recommended for 532 nm and 785 nm excitation wavelengths and OD4 or greater for a 993 nm excitation wavelength.

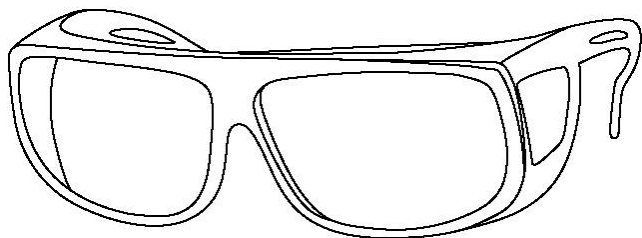

A0048421

Figure 1. Laser safety glasses

For more assistance with taking appropriate precautions and setting the proper controls when dealing with lasers and their hazards, refer to the most current version of ANSI Z136.1 or IEC 60825-14.

## 2.6 Service safety

Follow your company's safety instructions when removing a process probe from the process interface for service. Always wear proper protective equipment when servicing the equipment.

## 2.7 Important safeguards

- Do not use the Rxn-10 probe for anything other than its intended use.
- Do not look directly into the laser beam.
- Do not point the laser at a mirrored/shiny surface or a surface that may cause diffuse reflections. The reflected beam is as harmful as the direct beam.
- When not in use, close the shutter on the Rxn-10 probe. If an optic cap is available, place it on the unused optic.
- Always use a laser beam block to avoid inadvertent scatter of laser radiation.

## 2.8 Product safety

This product is designed to meet all current safety requirements, has been tested, and shipped from the factory in a safe operating condition. The relevant regulations and international standards have been observed. Devices connected to an analyzer must also comply with the applicable analyzer safety standards.

Endress+Hauser Raman spectroscopy systems incorporate the following safety features to conform to the United States Government requirements found in Title 21 of the [Code of Federal Regulations](#) (21 CFR) Chapter 1, Subchapter J as administered by the [Center for Devices and Radiological Health](#) (CDRH) and IEC 60825-1 as administered by the [International Electrotechnical Commission](#).



### 2.8.1 CDRH and IEC compliance

Endress+Hauser Raman analyzers are certified by Endress+Hauser to meet CDRH and IEC 60825-1 design and manufacturing requirements.

Endress+Hauser Raman analyzers have been registered with the CDRH. Any unauthorized modifications to an existing Raman Rxn analyzer or accessory may result in hazardous radiation exposure. Such modifications may result in the system being no longer in conformance with federal requirements as certified by Endress+Hauser.

### 2.8.2 Laser safety interlock

The Rxn-10 probe, as installed, forms part of the interlock circuit. If the fiber cable is severed, the laser will turn off within milliseconds of the breakage.

#### NOTICE

#### Handle probes and cables with care.

Fiber cables should NOT be kinked and should be routed to maintain the minimum bend radius of 152.4 mm (6 in.).

- ▶ Permanent damage may result if cables are not routed appropriately.

### 2.8.3 Laser radiation emission indicator and laser beam shutter

In addition to the CDRH-compliant indicators on the base unit of a Raman Rxn analyzer, the Rxn-10 probe has an electrically powered CRDH-compliant laser emission indicator.

The Rxn-10 probe incorporates a laser beam shutter that can be closed to prevent laser emission. Position “I” indicates emission potential. Moving the lever passed position “O” indicates emission is shuttered.

#### WARNING

**The shutter lever must be moved beyond the “O” to the detent to completely shutter the emission.**

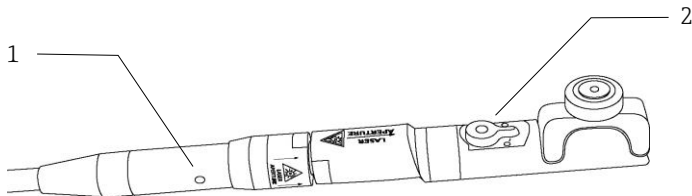
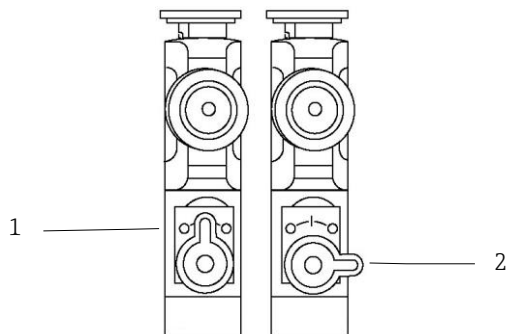

Figure 2. Location of the laser emission indicator and laser beam shutter

#	Description
1	laser emission indicator
2	laser beam shutter



A0048409

Figure 3. ON and OFF positions of the laser beam shutter

#	Description
1	ON
2	OFF

### 3 Product description

#### 3.1 The Rxn-10 probe

The Rxn-10 Raman spectroscopic probe, powered by Kaiser Raman technology, offers multi-purpose convenience for both solids and liquids analysis in the laboratory environment. It is designed to be compatible with Endress+Hauser Raman Rxn analyzers operating at 532 nm, 785 nm, or 993 nm. Each Rxn-10 probe is designed specifically for a single laser excitation wavelength.

The fiber cable is not removable from the body of the Rxn-10 probe.

#### 3.2 Rxn-10 probe and accessory optics

The probe head is compatible with the following accessory optics to meet the requirements of different applications. Refer to the following for additional details:

- *Accessory optics for the Rxn-10 probe Operating Instructions*
- *Raman flow assemblies Operating Instructions*

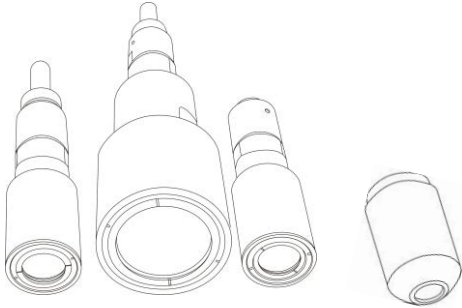
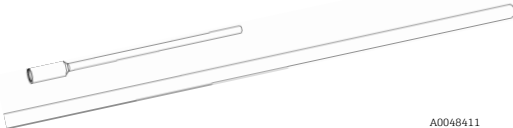
	Optics	Applications
Non-contact optics	 <p style="text-align: center;">A0048410                      A0048676</p>	For use with solids or turbid media. Also well-suited for delicate or corrosive liquids when sample contamination or damage to optical components is a concern.
Immersion optics (IO)	 <p style="text-align: right;">A0048411</p>	For use in reaction vessels, laboratory reactors, or process streams.

	Optics	Applications
bIO-Optic	 <p style="text-align: right;">A0048412</p>	For use with continuous inline measurement in benchtop bioreactor/fermenter applications requiring headplate entry.
Bio multi optic and bio sleeve	 <p style="text-align: right;">A0051184</p>	For use with continuous inline measurement in benchtop bioreactor/fermenter applications requiring headplate entry.
Raman optic system for single use	 <p style="text-align: right;">A0048413</p>	For use with disposable fittings for single-use applications.
Raman flow assembly (includes micro flow bench and micro flow cell)	 <p style="text-align: right;">A0052578</p>	For use with lower flow rate liquids, where monitoring a dynamic process stream provides valuable information, and speed or limit of detection are particularly important.

Table 3. Optics and applications

## 4 Incoming product acceptance and product identification

### 4.1 Incoming acceptance

- Verify that the packaging is undamaged. Notify the supplier of any damage to the packaging. Keep the damaged packaging until the issue has been resolved.
- Verify that the contents are undamaged. Notify the supplier of any damage to the delivery contents. Keep the damaged goods until the issue has been resolved.
- Check that the delivery is complete and nothing is missing. Compare the shipping documents with your order.
- Pack the product for storage and transportation in such a way that it is protected against impact and moisture. The original packaging offers the best protection. Make sure to comply with the permitted ambient conditions found in the *Rxn-10 Raman spectroscopic probe Operating Instructions* manual.

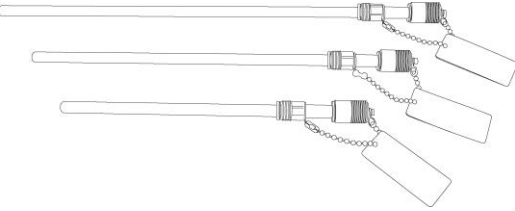
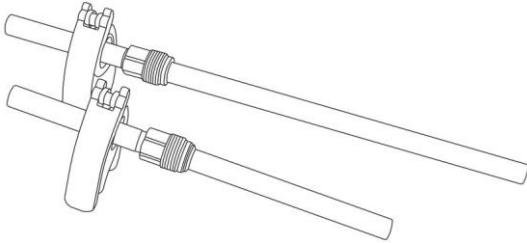
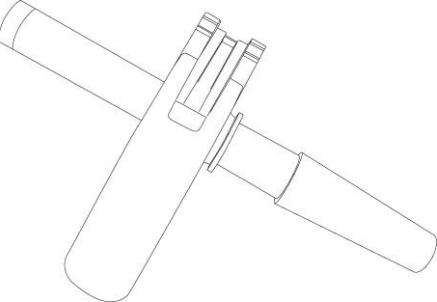
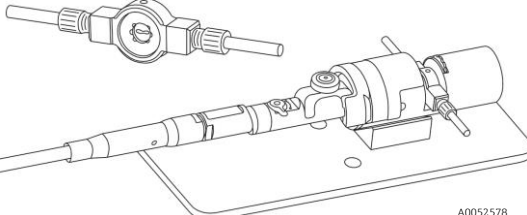
If you have any questions, please contact your supplier or your local sales center.

#### NOTICE

**Probe may be damaged during transport if packaged inadequately.**

### 4.2 Product identification

#### 4.2.1 Label

At a minimum, the probe/tag is labeled with the following information:

- Endress+Hauser branding
- Serial number

Where size allows, the following information is also included:

- Product identification (e.g., Rxn-10)
- Extended order code
- Manufacturer information
- Key functional aspects of the probe (e.g., material, wavelength, focal depth)
- Safety warnings and certification information, as applicable

Compare the information on the label/tag with the order.

#### 4.2.2 Manufacturer address

Endress+Hauser  
371 Parkland Plaza  
Ann Arbor, MI 48103 USA

### 4.3 Scope of delivery



The scope of delivery comprises:

- Rxn-10 probe
- *Rxn-10 Raman spectroscopic probe Operating Instructions* manual
- Certificate of Product Performance
- Local declarations of conformity, if applicable
- Rxn-10 probe optional accessories, if applicable
- Material certificates, if applicable

If you have any questions, please contact your supplier or local sales center.

## 5 Installation

During installation, standard eye and skin safety precautions for Class 3B laser products (as per IEC 60825-14 or ANSI Z136.1) should be observed. Additionally, observe the following:

 <b>WARNING</b>	<p><b>Standard precautions for laser products should be observed.</b></p> <ul style="list-style-type: none"> <li>▶ Probes should always be shuttered or pointed away from people toward a diffuse target if not installed in a sample chamber.</li> </ul>
 <b>CAUTION</b>	<p><b>The laser input into the Rxn-10 probe must not exceed 499 mW.</b></p> <p><b>If stray light is allowed to enter an unused probe, it will interfere with data collected from a used probe and may cause calibration failure or measurement errors.</b></p> <ul style="list-style-type: none"> <li>▶ Unused probes should ALWAYS be shuttered to prevent stray light from entering the probe. If an optic cap is available, place it on the unused optic.</li> </ul>
<b>NOTICE</b>	<p><b>When installing the probe <i>in situ</i>, the user must provide the strain relief to the fiber optic cable at the probe installation location.</b></p>

### 5.1 Probe and fiber optic connection

The Rxn-10 probe is compatible with the complete line of Endress+Hauser Raman Rxn analyzers.

The Rxn-10 probe connects to the Raman Rxn analyzer via one of the following:

- Fiber channel (FC) cable assembly for use with Raman Rxn analyzers built before September 2019
- Electro-optical (EO) fiber cable for use with Raman Rxn analyzers built during or after September 2019

The fiber cable is not removable from the body of the Rxn-10 probe. Optional extension fiber cables are available.

Refer to the applicable Raman Rxn analyzer operating instructions for analyzer connection details.

**NOTICE**

**Connection of the probe to the FC cable assembly or the EO fiber cable must be conducted by a qualified Endress+Hauser engineer or specially trained technical personnel.**

- ▶ Unless trained by qualified personnel, customer attempts to connect the probe to the fiber optic cable can result in damage and may void the warranty.
- ▶ Contact your local Endress+Hauser service representative for additional support regarding the probe and fiber cable connection.

**5.1.1 FC cable assembly**

The FC cable assembly connects the Rxn-10 probe to the analyzer via the following:

- Electrical interlock connector
- Yellow (YE) excitation fiber for laser output
- Red (RD) collection fiber for spectrograph input

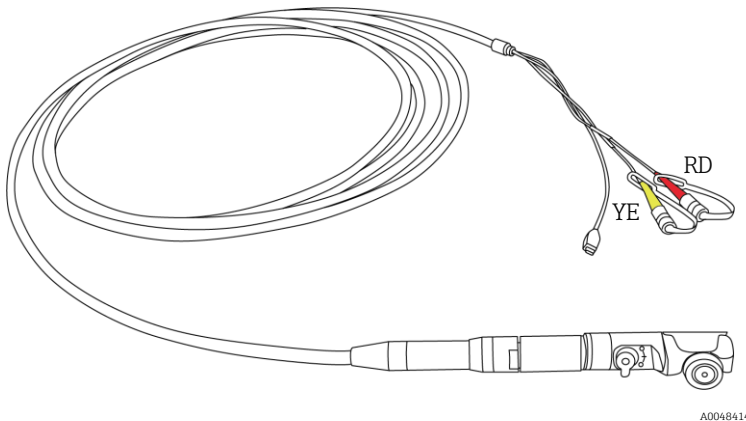

A0048414

Figure 4. Rxn-10 probe with FC cable assembly



### 5.1.2 EO fiber cable

The EO fiber cable connects the Rxn-10 probe to the analyzer with a single, robust connector that contains the excitation and collection fiber-optics as well as an electrical laser interlock.

An EO extension cable is available for longer cable runs or installation in conduit.

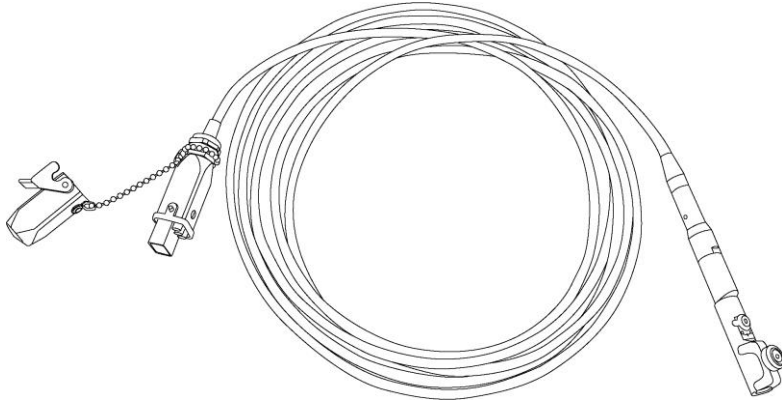

A0048415

Figure 5. Rxn-10 probe with EO fiber cable

## 5.2 Installing optics

The Rxn-10 probe is compatible with a variety of immersion optics, non-contact optics, and micro flow bench with micro flow cell. The probe head has a compression clamp that secures the immersion optics or micro flow bench. The clamp also holds the adapter for non-contact optics.

Before installation, ensure any protective covers are removed from the optics.

When replacing an optic on a probe head, refer to [Section 6.2](#) →  to perform an intensity calibration for that probe head with the new optic.

### 5.2.1 Installing immersion optics and bIO-Optics

Endress+Hauser immersion optics and bIO-Optics slip into the Rxn-10 probe and are secured by a torque limiting, thumb screw-based clamp. The thumb screw on the Rxn-10 probe should never be fully removed.

#### **WARNING**

**When installing or removing immersion optics, ensure the laser and emission shutter are in the closed position.**

To install an immersion optic:

1. If necessary, loosen the torque limiting thumb screw on the Rxn-10 probe by turning the screw counter-clockwise approximately one turn (do not remove). Then find the probe end of the optic, which is the end that includes the product markings.
2. Insert the probe end of the optic through the end optic clamp.
3. Push the optic back until it stops.
4. Tighten the thumb screw by gently turning it clockwise until there is an audible “click” sound. This indicates the thumb screw has reached the desired torque. Failure to tighten the screw will result in the optic coming loose, potentially damaging the optic.
5. After installing an optic on a probe head, use the Raman Calibration Accessory to perform an intensity calibration for the probe head with the new optic before use.

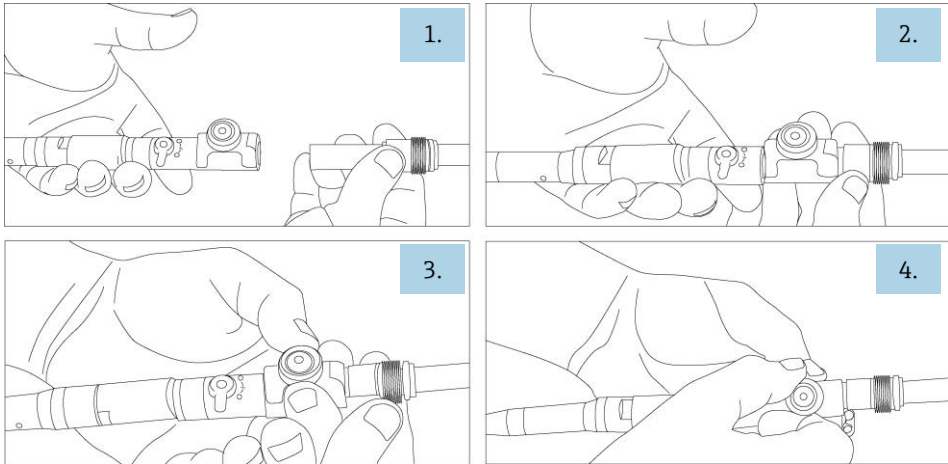

A004B416

Figure 6. Installing an immersion optic (IO) or bIO-Optic into the Rxn-10 probe

To remove an immersion optic:

Loosen the torque limiting thumb screw by turning it counter-clockwise approximately one turn so that the immersion optic is released from its clamp. Do not remove the screw. Then slide the immersion optic out.

### 5.2.2 Installing the bio multi optic

The Endress+Hauser bio multi optic slips into the Rxn-10 probe and is secured by a torque limiting thumb screw-based clamp. The thumb screw on the Rxn-10 probe should never be fully removed.

**⚠ WARNING**

**When installing or removing optics, ensure the laser and emission shutter are in the closed position.**

To install the optic into the probe:

1. If necessary, loosen the metal thumb screw on the Rxn-10 probe by turning the screw counter-clockwise approximately one turn (do not remove).
2. Insert the optic through the end optic clamp.

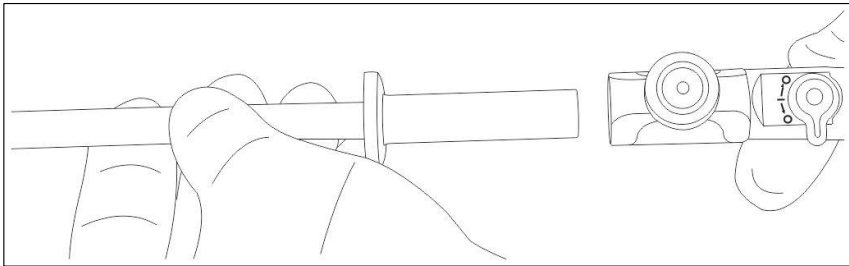

A0051185

*Figure 7. Inserting the bio multi optic into the Rxn-10 probe*

3. Push the optic back until it stops.

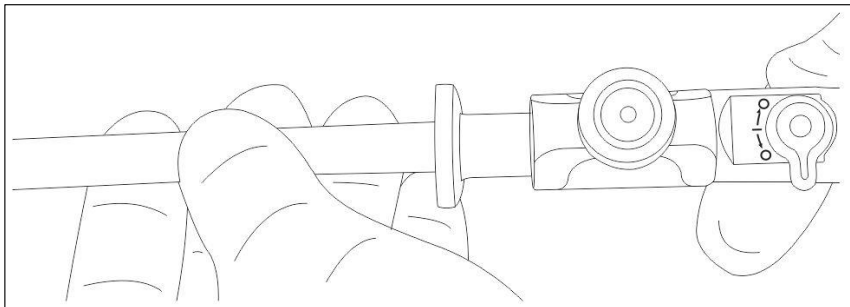

A0051186

*Figure 8. Final position of bio multi optic in the Rxn-10 probe*

4. Tighten the thumb screw by gently turning it clockwise until there is an audible “click” sound. This indicates the thumb screw has reached the desired torque. Failure to tighten the screw will result in the optic coming loose, potentially damaging the optic.

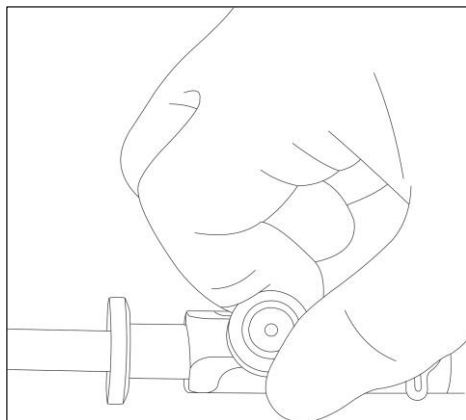

A0051187

Figure 9. Tightening the thumb screw on the Rxn-10 probe

5. After installing an optic into a probe, use the multi optic calibration accessory to perform an intensity calibration for the probe with the new optic. Alternately, the Raman Calibration Accessory (HCA) may be used, but a bio sleeve is required.

To remove the bio multi optic from the Rxn-10 probe:

Loosen the torque limiting thumb screw by turning it counter-clockwise approximately one turn so that the optic is released from its clamp. Do not remove the screw. Then slide the optic out.

### 5.2.3 Installing the Raman optic system for single use

The Endress+Hauser Raman optic system for single use slips into the Rxn-10 probe and is secured by a torque limiting, thumb screw-based clamp. The thumb screw on the Rxn-10 probe should never be fully removed.

#### **⚠ WARNING**

**When installing or removing optics, ensure the laser and emission shutter are in the closed position.**

To install the Raman optic system for single use:

1. If necessary, loosen the metal thumb screw on the Rxn-10 probe by turning the screw counter-clockwise approximately one turn (do not remove). Then insert the optic through the end optic clamp.
2. Push the optic back until it stops.

3. Tighten the thumb screw by gently turning it clockwise until there is an audible “click” sound. This indicates the thumb screw has reached the desired torque. Failure to tighten the screw will result in the optic coming loose, potentially damaging the optic.

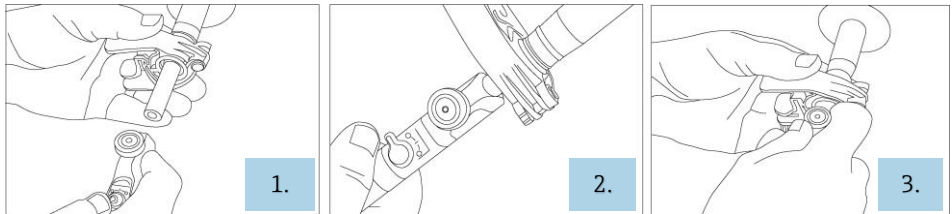

A0046417

Figure 10. Installing the Raman optic system for single use into the Rxn-10 probe

4. After installing an optic into a probe, and before it is connected to the fitting, use the multi optic calibration accessory to perform an intensity calibration for the probe with the new optic. Alternately, the Raman Calibration Accessory (HCA) and single use calibration adapter may be used.

To remove the Raman optic system for single use:

Loosen the torque limiting thumb screw by turning it counter-clockwise approximately one turn so that the optic is released from its clamp. Do not remove the screw. Then slide the optic out.

#### 5.2.4 Installing non-contact optics

The non-contact optics offered with the Rxn-10 probe are threaded, so a threaded adapter is required to attach the optic to the Rxn-10 probe.

#### **⚠ WARNING**

**When installing or removing non-contact optics, ensure the laser and emission shutter are in the closed position.**

To install a non-contact optic:

1. If necessary, loosen the metal thumb screw on the Rxn-10 probe by turning the screw counter-clockwise approximately one turn (do not remove). Then find the narrow, non-threaded end of the adapter.
2. Insert the narrow end of the adapter through the clamp. Push the adapter back until it stops.
3. Tighten the thumb screw by gently turning it clockwise until there is an audible “click” sound. This indicates the thumb screw has reached the desired torque. Failure to tighten the screw will result in the adapter coming loose.
4. Find the externally threaded end of the non-contact optic.
5. Screw a non-contact optic into the threaded end of the adapter.

6. After installing an optic into a probe head, use the Raman Calibration Accessory to perform an intensity calibration for the probe head with the new optic before use.

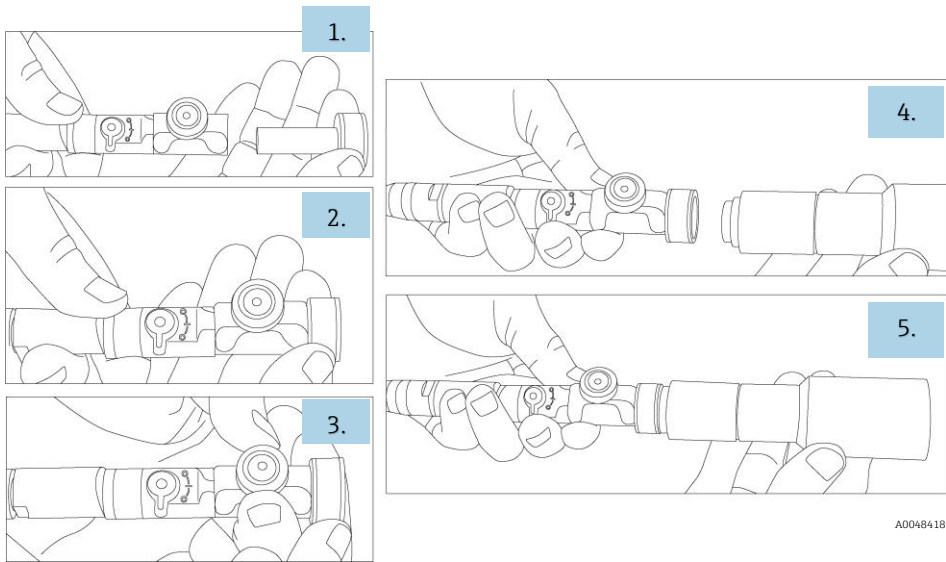

Figure 11. Installing an adapter and non-contact optic into the Rxn-10 probe

To remove a non-contact optic:

Unscrew the non-contact optic from the adapter. If an immersion optic will be used, remove the adapter by turning the torque limiting thumb screw counter-clockwise approximately one turn until the adapter is released from the clamp. Then slide the adapter out.

### 5.2.5 Installing the micro flow bench

The Endress+Hauser micro flow bench slips into the Rxn-10 probe and is secured by a torque limiting thumb screw-based clamp. The thumb screw on the Rxn-10 probe should never be fully removed.

#### **⚠ WARNING**

**When installing or removing optics, ensure the laser and emission shutter are in the closed position.**

To install the micro flow bench into the probe:

1. If necessary, loosen the metal thumb screw on the Rxn-10 probe by turning the screw counter-clockwise approximately one turn (do not remove).
2. Insert the end optic clamp of the probe onto the Rxn-10 adapter of the micro flow bench.

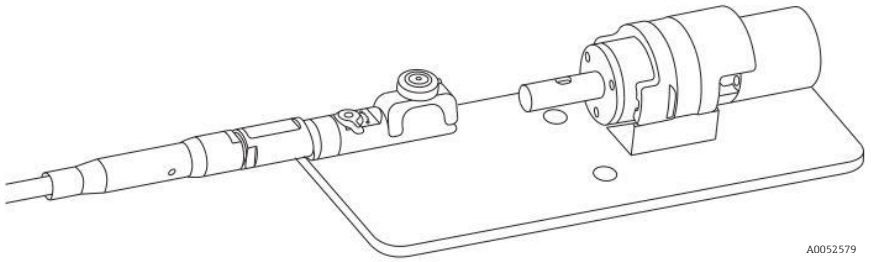

A0052579

Figure 12. Inserting the Rxn-10 probe onto the Rxn-10 adapter of the micro flow bench

3. Slide the probe over the Rxn-10 adapter of the micro flow bench until it stops.

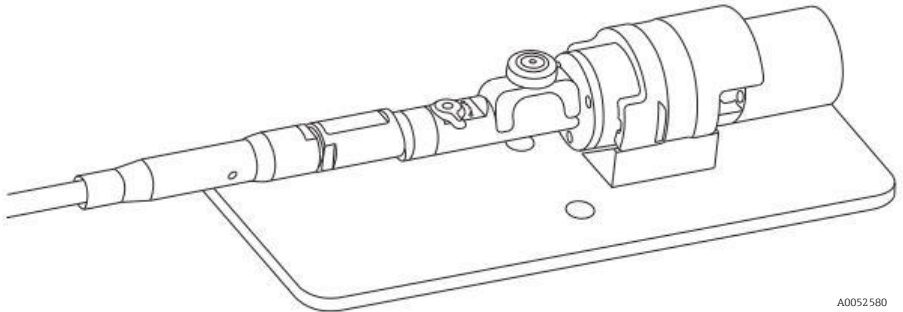

A0052580

Figure 13. Final position of the Rxn-10 probe with the micro flow bench

4. Tighten the thumb screw by gently turning it clockwise until there is an audible “click” sound. This indicates the thumb screw has reached the desired torque. Failure to tighten the screw will result in the optic coming loose, potentially damaging the optic.
5. After installing the micro flow bench, use the micro flow bench calibration kit to perform an intensity calibration for the probe with the new optic.

To remove the Rxn-10 probe from the micro flow bench:

Loosen the torque limiting thumb screw by turning it counter-clockwise approximately one turn so that the Rxn-10 adapter is released from the clamp. Do not remove the screw. Then slide the probe off of the adapter.

## 6 Commissioning

The Rxn-10 probe is delivered ready to connect to the Raman Rxn analyzer. No additional alignment or adjustment to the probe is required. Follow the instructions below to commission the probe for use.

### 6.1 Receipt of probe

Perform the steps for incoming product acceptance described in Section 4.1 → .

### 6.2 Probe calibration and verification

The probe and the analyzer must be calibrated before use.

#### 6.2.1 Multi optic calibration and verification accessories

Refer to the *Multi optic calibration kit Operating Instructions* for additional information about the multi optic calibration accessory.

##### 6.2.1.1 Multi optic calibration accessory

After installing the bio multi optic or the Raman optic system for single use into the Rxn-10 probe, use the multi optic calibration accessory to perform an intensity calibration for the probe head with the new optic.

If the multi optic calibration accessory is not available, a Raman Calibration Accessory (HCA) may be used for calibration as follows:

- Bio multi optic: with bio sleeve and 12 mm HCA adapter
- Raman optic system for single use: with the single use calibration adapter and 12 mm HCA adapter

##### 6.2.1.2 Multi optic verification accessory

The multi optic verification accessory should be used for verification of the bio multi optic or Raman optic system for single use.

#### NOTICE

**Do NOT immerse the bio multi optic or optic for single use directly into a sample.**

If the multi optic verification accessory is not available, verification of the bio multi optic or Raman optic system for single use may be performed using a bIO-Sample Chamber and an additional bio sleeve (for bio multi optic) or a single use calibration adapter (for single use optic). Refer to the applicable Raman Rxn analyzer operating instructions for information about using the bIO-Sample Chamber.

#### 6.2.2 Raman Calibration Accessory

After installing an immersion optic, non-contact optic, or bIO-Optic into the probe head, use the Raman Calibration Accessory (HCA) to perform an intensity calibration for the probe head with the new optic.



If the HCA is used with the Raman optic system for single use, an additional single use calibration adapter is installed onto the optic. The optic/calibration adapter combination is then inserted into an HCA adapter attached to the HCA head.

Refer to the *Raman Calibration Accessory Operating Instructions* for additional information about the HCA and adapters.

### 6.2.3 Micro flow bench calibration and verification cells

The micro flow bench calibration and verification cells are intended to calibrate and verify the micro flow bench. No other options are compatible.

Refer to the *Flow bench calibration kit Operating Instructions* for additional information about the micro flow bench calibration and verification cells.

#### NOTICE

**Do NOT immerse, flow, or contaminate the micro flow bench calibration or verification cells directly with sample.**

#### 6.2.3.1 Micro flow bench calibration cell

After installing the micro flow bench, use the micro flow bench calibration cell to perform an intensity calibration for the probe head and micro flow bench.

#### 6.2.3.2 Micro flow bench verification cell

The micro flow bench verification cell is used for probe verification with the micro flow bench.

### 6.2.4 Performing calibration and verification

Refer to the applicable Raman Rxn analyzer operating instructions for steps to:

- Perform internal analyzer calibration; may include alignment calibration, full wavelength calibration or full laser wavelength calibration depending on status of analyzer
- Perform probe calibration; requires multi optic calibration accessory, micro flow bench calibration cell, or HCA with an appropriate optic adapter
- Perform probe verification; verifies the calibration results using a standard reference sample and one of the following:
  - BIO-Sample Chamber
  - multi optic verification accessory
  - micro flow bench verification cell
- View calibration and verification reports

The Raman RunTime software will not allow spectra to be collected without passing internal analyzer and probe calibrations. Passing the probe verification step is not required but highly recommended.

Raman Rxn analyzer operating instructions are available by searching the Downloads area of the Endress+Hauser web site: <https://endress.com/downloads>

## 7 Operation

The Endress+Hauser Rxn-10 probe is a versatile probe designed for product and process development. The probe variants are designed to be compatible with Endress+Hauser Raman Rxn analyzers operating at 532 nm, 785 nm, or 993 nm. The Rxn-10 probe accepts a variety of interchangeable optics.

Refer to the applicable Raman Rxn analyzer operating instructions and optics operating instructions for additional instructions for use.

## 8 Diagnostics and troubleshooting

Refer to the table below when troubleshooting issues with the Rxn-10 probe. When an attached probe is not in use, ensure the laser beam shutter on the probe is in the OFF position (O) to prevent stray light from entering the system.

If the probe is damaged, isolate the probe from the process stream and turn off the laser prior to evaluation. Contact your service representative as needed for assistance.

For actions related to accessory optics (e.g., cleaning), consult the applicable operating instructions for details.

Symptom	Possible cause	Action	
1	Substantial reduction in signal or signal-to-noise ratio	Window fouling of attached optic	<ol style="list-style-type: none"> <li>Carefully remove optic attached to the probe from the sampling environment, decontaminate, and inspect optical window.</li> <li>If necessary, clean the window before returning the optic to service.</li> </ol>
	Cracked but intact fiber	Verify condition of fiber and contact your service representative for replacement.	
2	Complete loss of signal while laser is powered and laser emission indicator is lit	Broken fiber without interlock wire breakage	Ensure all fiber connections are secure.
	Laser beam shutter is in the closed (O) position	Ensure the laser beam shutter is in the open (I) position.	
3	Laser emission indicator on probe is not lit	Damaged fiber assembly	Look for signs of breakage in fiber. Contact your service representative for replacement.
	Fiber cable EO connector not secured/latched	Ensure EO connector is properly connected and latched at the probe (if applicable) and at the analyzer.	
	Remote interlock connector disconnected	Ensure the twist-lock remote interlock connector at the rear of analyzer (next to fiber EO connector) is connected for the specific channel.	
4	Unstable signal and contamination visible behind optic window	Window seal failure of attached optic	<ol style="list-style-type: none"> <li>Examine the area inside the window of attached optic for moisture or condensation.</li> <li>Examine the attached optic for fluid penetration or signs of sample fluid in the optic body (e.g., corrosion, residue).</li> <li>Look for any sign of spectral deviation.</li> <li>If any of the above are noted, contact your service representative to return the probe to the manufacturer.</li> </ol>

Symptom		Possible cause	Action
5	Decreased laser power or collection efficiency	Contaminated fiber connection	Carefully clean the fiber ends at the probe. Refer to the applicable Raman Rxn analyzer operating instructions for cleaning instructions and steps for starting up a new probe.
6	Laser interlock on analyzer causes laser to shut down	Laser interlock activated	Check for fiber breakage on all connected fiber optic cable channels and ensure remote interlock connectors are in place on each channel.
7	Unrecognized bands or patterns in the spectra	Cracked but intact fiber	Verify possible causes and contact your service representative to return the damaged product.
		Contaminated tip of attached optic	
		Contaminated internal optics of probe	
8	Other unexplained negative performance of the probe	Optic is not seated properly	Reseat the optic and perform a probe calibration. Refer to the applicable Raman Rxn analyzer operating instructions for probe calibration steps.
		Thumb screw is not properly secured to the probe	Tighten the nut in the center of the thumb screw using a hex key.
		Physical damage to probe head or optics	Contact your service representative to return the damaged product.

Table 4. Troubleshooting

[www.addresses.endress.com](http://www.addresses.endress.com)

---