



Brief Operating Instructions

Cerabar PMP21

IO-Link

Process pressure measurement

These Instructions are Brief Operating Instructions; they are not a substitute for the Operating Instructions pertaining to the device.

Detailed information about the device can be found in the Operating Instructions and the other documentation:

Available for all device versions via:

- Internet: www.endress.com/deviceviewer
- Smart phone/tablet: *Endress+Hauser Operations App*

Basic safety instructions

Requirements for the personnel

- Personnel must meet the following requirements to perform their tasks:
- ▶ Trained, qualified specialists must be suitably qualified to perform this function and task
 - ▶ Are authorized by the plant owner/operator
 - ▶ Are familiar with federal/national regulations
 - ▶ They must have read and understood the instructions in the manual, supplementary documentation and certificates (depending on the application) prior to starting work
 - ▶ Follow instructions and comply with basic conditions

Intended use

The Cerabar is used to measure absolute and gauge pressure in gases, vapors and liquids. The process-wetted materials of the measuring device must have an adequate level of resistance to the media.

The measuring device may be used for the following measurements (process variables)

- in compliance with the limit values specified under "Technical data"
- in compliance with the conditions that are listed in this manual.

Product identification

Manufacturer address

Endress+Hauser SE+Co. KG
Hauptstraße 1
79689 Maulburg, Germany
Place of manufacture: See nameplate.

Mounting

Mounting requirements

- No moisture may enter the housing when installing or operating the device, or when establishing the electrical connection.
- For metal M12 plugs: Do not remove the protective cap (only in IP69) of the M12 plug connection until shortly before electrical connection.
- Do not clean or touch process membranes with hard or pointed objects.
- Do not remove the protection on the process membrane until just before installation.
- Always tighten the cable entry firmly.
- Point the cable and plug downwards where possible to prevent moisture from entering (e.g. rain or condensation water).
- Protect housing against impact.
- The following note applies to devices with a gauge pressure measuring cell:

NOTICE

If a heated device is cooled during the cleaning process (e.g. by cold water), a vacuum develops for a short time, whereby moisture can penetrate the measuring cell through the pressure compensation element (1). Device could be destroyed!

Measured process variable

PMP21: Gauge pressure or absolute pressure

Operational safety

Risk of injury!

- ▶ Operate the device in proper technical condition and fail-safe condition only.
- ▶ The operator is responsible for the interference-free operation of the device.

Hazardous area

To eliminate the risk of danger to persons or the facility when the device is used in the approval-related area (e.g. explosion protection, pressure equipment safety):

- ▶ Check the nameplate to verify if the ordered device can be put to its intended use in the approval-related area.
- ▶ Observe the specifications in the separate supplementary documentation, such as the XA or SD, which is an integral part of these Instructions.

- ▶ Mount the device with the pressure compensation element (1) pointing diagonally downwards or to the side as much possible.

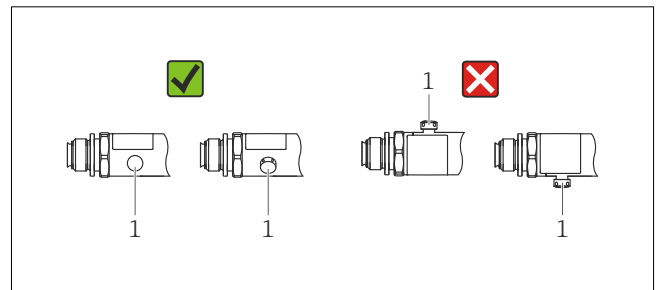

Influence of the installation position

Any orientation is possible. However, the orientation may cause a zero point shift, i.e. the measured value does not show zero when the vessel is empty or partially full.

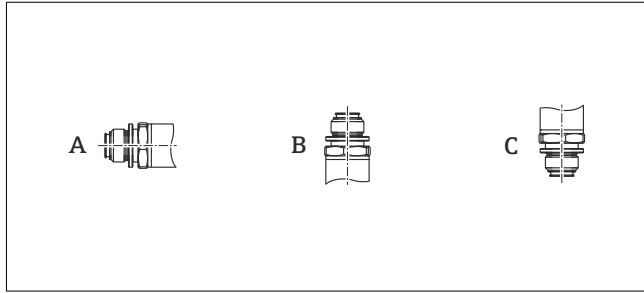

Process membrane axis is horizontal (A)	Process membrane pointing upwards (B)	Process membrane pointing downwards (C)
Calibration position, no effect	Up to +4 mbar (+0.058 psi)	Up to -4 mbar (-0.058 psi)

Mounting location

Electrical connection

Connecting the measuring unit

Terminal assignment

WARNING

Risk of injury from the uncontrolled activation of processes!

- ▶ Switch off the supply voltage before connecting the device.
- ▶ Make sure that downstream processes are not started unintentionally.

WARNING

An incorrect connection compromises electrical safety!

- ▶ In accordance with IEC/EN 61010, a suitable circuit breaker must be provided for the device.
- ▶ **Non-hazardous area:** To meet device safety specifications according to the IEC/EN61010 standard, the installation must ensure that the maximum current is limited to 500 mA.
- ▶ **Hazardous area:** The maximum current is restricted to $I_i = 100$ mA by the transmitter power supply unit when the device is used in an intrinsically safe circuit (Ex ia).
- ▶ Protective circuits against reverse polarity are integrated.

NOTICE

Damage to analog input of PLC resulting from incorrect connection

- ▶ Do not connect the active PNP switch output of the device to the 4 to 20 mA input of a PLC.

Connect the device in the following order:

1. Check whether the supply voltage matches the supply voltage indicated on the nameplate.
2. Connect the device as indicated in the following diagram.

Switch on the supply voltage.

Pressure measurement in gases

Mount the device with the shutoff device above the tapping point so that any condensate can flow into the process.

Pressure measurement in vapors

For pressure measurement in vapors, use a siphon. The siphon reduces the temperature to almost ambient temperature. Mount the device with the shutoff device at the same level as the tapping point.

Observe the max. permitted ambient temperature of the transmitter!

Pressure measurement in liquids

Mount the device with the shutoff device at the same level or below the tapping point, see Operating Instructions.

Level measurement

- Always install the device below the lowest measuring point.
- Do not install the device at the following positions:
 - In the filling curtain
 - In the tank outlet
 - in the suction area of a pump
 - Or at a point in the tank which could be affected by pressure pulses from the agitator.

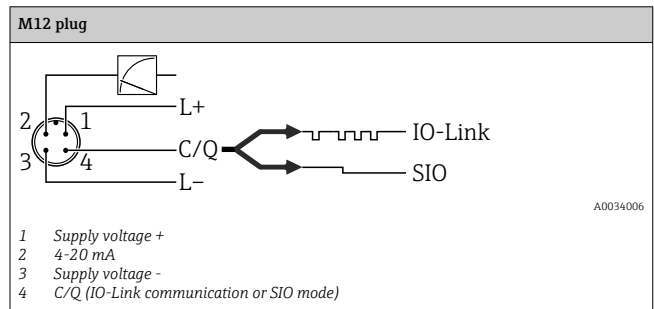

Supply voltage

Electronic version	Supply voltage
IO-Link	10 to 30 V _{DC} IO-Link communication is guaranteed only if the supply voltage is at least 18 V.

Current consumption and alarm signal

Electronic version	Current consumption	Alarm signal ¹⁾
IO-Link	Maximum current consumption: ≤ 300 mA	

1) For MAX alarm (factory setting)