

Brief Operating Instructions

Solitrend MMP60

Material moisture measurement

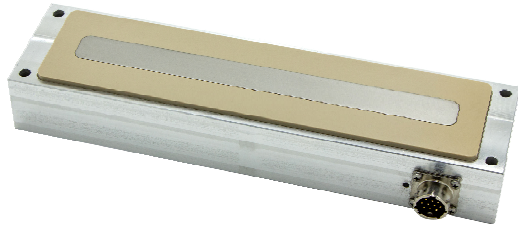

These Brief Operating Instructions are not a substitute for the Operating Instructions pertaining to the device.

Detailed information is provided in the Operating Instructions and other documentation.

Available for all device versions via:

- Internet: www.endress.com/deviceviewer
- Smartphone/tablet: Endress+Hauser Operations app



A0023555

Table of contents

1	About this document	4
1.1	Symbols used	4
2	Basic safety instructions	4
2.1	Requirements for personnel	4
2.2	Intended use	5
2.3	Workplace safety	5
2.4	Operational safety	5
2.5	Product safety	6
3	Product description	6
3.1	Product design	6
4	Incoming acceptance and product identification	7
4.1	Incoming acceptance	7
4.2	Product identification	8
4.3	Manufacturer's address	8
4.4	Storage, transport	8
5	Mounting	9
5.1	Mounting requirements	9
5.2	Mounting the device	9
5.3	Post-mounting check	12
6	Electrical connection	12
6.1	Connecting requirements	12
6.2	Connecting the device	12
6.3	Post-connection check	13
7	Operation options	14
8	Commissioning	14
8.1	Analog outputs for measured value output	14
8.2	Operating mode	16
8.3	Calibration curve set A for general bulk solids applications	17
8.4	Settings	19
8.5	Special functions	20
9	Diagnostics and troubleshooting	20
9.1	Different moisture value	20

1 About this document

1.1 Symbols used

1.1.1 Symbols for certain types of information and graphics

Tip

Indicates additional information



Reference to documentation



Reference to graphic



Notice or individual step to be observed

1, 2, 3.

Series of steps



Result of a step

1, 2, 3, ...

Item numbers

A, B, C, ...

Views

2 Basic safety instructions

2.1 Requirements for personnel

The personnel for installation, commissioning, diagnostics and maintenance must fulfill the following requirements:

- ▶ Trained, qualified specialists must have a relevant qualification for this specific function and task.
- ▶ Personnel must be authorized by the plant owner/operator.
- ▶ Be familiar with federal/national regulations.
- ▶ Before starting work: personnel must read and understand the instructions in the manual and supplementary documentation as well as the certificates (depending on the application).
- ▶ Personnel must follow instructions and comply with general policies.

The operating personnel must fulfill the following requirements:

- ▶ Personnel are instructed and authorized according to the requirements of the task by the facility's owner-operator.
- ▶ Personnel follow the instructions in this manual.

2.2 Intended use

Application and media

The device described in this manual is intended for the continuous moisture measurement of a wide variety of materials. Because of its operating frequency of approx. 1 GHz the device can also be used outside of closed metal vessels.

If operated outside of closed vessels, the device must be mounted in accordance with the instructions in the **Mounting** section. The operation of the devices does not present any health risk. If the limit values specified in the **Technical data** and the conditions listed in the instructions and additional documentation are observed, the measuring device may be used for the following measurements only:

- Measured process variables: material moisture, material conductivity and material temperature

To ensure that the device remains in proper condition throughout the operating period:

- ▶ Use the device only for media to which the process-wetted materials are sufficiently resistant.
- ▶ Observe the limit values in the "Technical data".

Incorrect use

The manufacturer is not liable for damage caused by improper or non-intended use.

Clarification of borderline cases:

- ▶ With regard to special fluids and media used for cleaning, the manufacturer is glad to assist in clarifying the corrosion resistance of materials in contact with the fluid, but does not accept any warranty or liability.

Residual risks

Due to the transfer of heat from the process and power dissipation within the electronics, the temperature of the electronics housing and the assemblies contained therein may increase to up to 70 °C (158 °F) during operation. The device may reach a temperature close to the medium temperature during operation.

Danger of burns from contact with surfaces!

- ▶ In the event of high medium temperatures, ensure protection against contact to prevent burns.

2.3 Workplace safety

For work on and with the device:

- ▶ Wear the required personal protective equipment according to federal/national regulations.

2.4 Operational safety

Risk of injury!

- ▶ Operate the device only if it is in proper technical condition, free from errors and faults.
- ▶ The operator is responsible for interference-free operation of the device.

Hazardous area

To eliminate the risk of danger to persons or the facility when the device is used in the approval-related area (e.g. explosion protection, pressure equipment safety):

- ▶ Check the nameplate to verify if the device ordered can be put to its intended use in the approval-related area.
- ▶ Observe the specifications in the separate supplementary documentation that is an integral part of this manual.

2.5 Product safety

This device is designed in accordance with good engineering practice to meet state-of-the-art safety requirements, has been tested, and left the factory in a condition in which it is safe to operate.

It meets the general safety standards and legal requirements. It also complies with the EU directives listed in the device-specific EU Declaration of Conformity. The manufacturer confirms this by affixing the CE mark to the device.

3 Product description

Device for measuring low-density bulk solids with conductivity values up to 1 mS/cm.

3.1 Product design

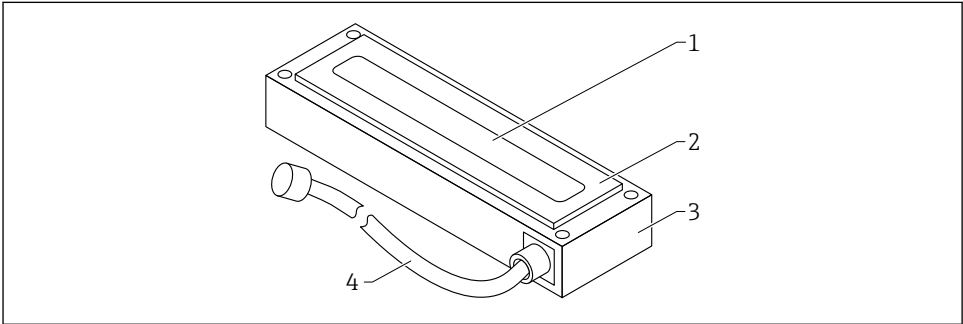

A0040364

1 Product design

- 1 Wave guide
- 2 Measuring cell; TECAPEEK
- 3 Housing

3.1.1 ATEX version

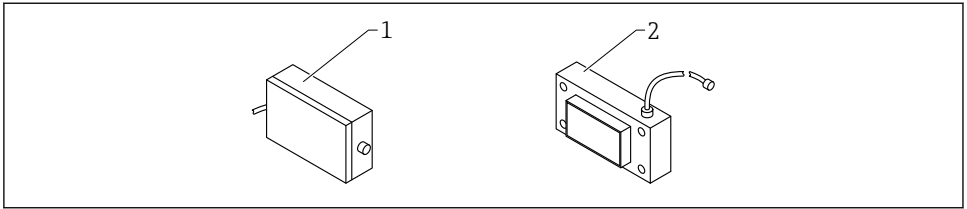

A0053310

2 Rectangular sensor, ATEX version

- 1 ATEX electronics housing
- 2 Rectangular sensor

3.1.2 Remote electronics (accessories)

In the case of the order option **Accessories mounted: remote electronics 120 °C (248 °F)**, the electronics module is located in a separate housing and is connected using the HF cable that is permanently connected to the sensor.

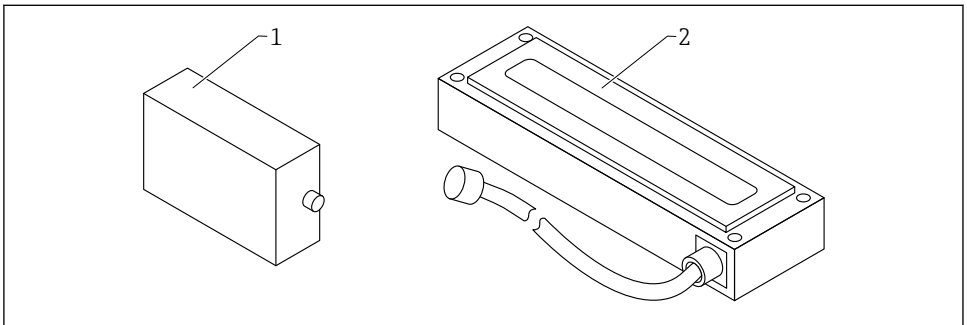

A0046896

- 1 Electronics housing
- 2 Rectangular sensor with HF cable 2.5 m (8.2 ft)

4 Incoming acceptance and product identification

4.1 Incoming acceptance

Check the following during incoming acceptance:

- Are the order codes on the delivery note and the product sticker identical?
- Are the goods undamaged?
- Do the nameplate data match the ordering information on the delivery note?

If required (see nameplate): Are the safety instructions (XA) provided?

 If one of these conditions is not met, please contact the manufacturer's sales office.

4.2 Product identification

The following options are available for identification of the device:

- Nameplate specifications
- Extended order code with breakdown of the device features on the delivery note
- ▶ Enter serial number from nameplates in *W@M Device Viewer* (www.endress.com/deviceviewer)
 - ↳ All of the information on the measuring device and on the scope of the technical documentation pertaining to the device is displayed.
- ▶ Enter the serial number from the nameplate into the *Endress+Hauser Operations App* or scan the 2-D matrix code on the nameplate.
 - ↳ All of the information on the measuring device and on the scope of the technical documentation pertaining to the device is displayed.

4.3 Manufacturer's address

Endress+Hauser SE+Co. KG
Hauptstraße 1
79689 Maulburg, Germany

4.4 Storage, transport

4.4.1 Storage conditions

- Permitted storage temperature: -40 to +70 °C (-40 to +158 °F)
- Use original packaging.

4.4.2 Transporting the product to the measuring point

Transport the device to the measuring point in the original packaging.

5 Mounting

5.1 Mounting requirements

- The device must be installed at a point in the process in such a way that ensures a constant bulk density, as the bulk density directly affects the calculation of the water content. Where necessary, a bypass should be created or structural measures may be needed at the place of installation to ensure that the material flow, and therefore the bulk density, over the measurement surface is constant.
- The measuring field of the device must be completely covered by material and the material height must exceed the minimum layer of material covering on the measurement surface (depends on the device type and moisture).
- The flow of material over the measurement surface must be continuous. With the software, it is possible to automatically detect and bridge gaps in material flow in intervals of seconds.
- No material deposits or buildup may form on the measuring cell surface, as this would falsify the readings.



Longer averaging times increase the stability of the measured value.

5.2 Mounting the device

The device can be installed with four screws (M5).

An appropriate cut-out must be created at the place of installation for the measuring cell and bores to secure it.

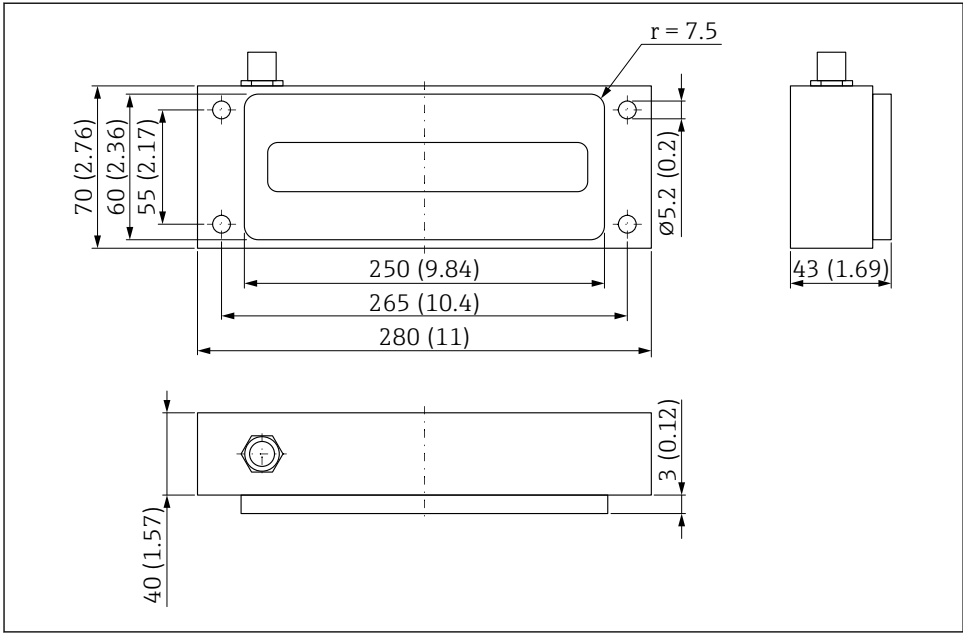

A0038452

3 Dimensions. Unit of measurement mm (in)

5.2.1 ATEX electronics housing

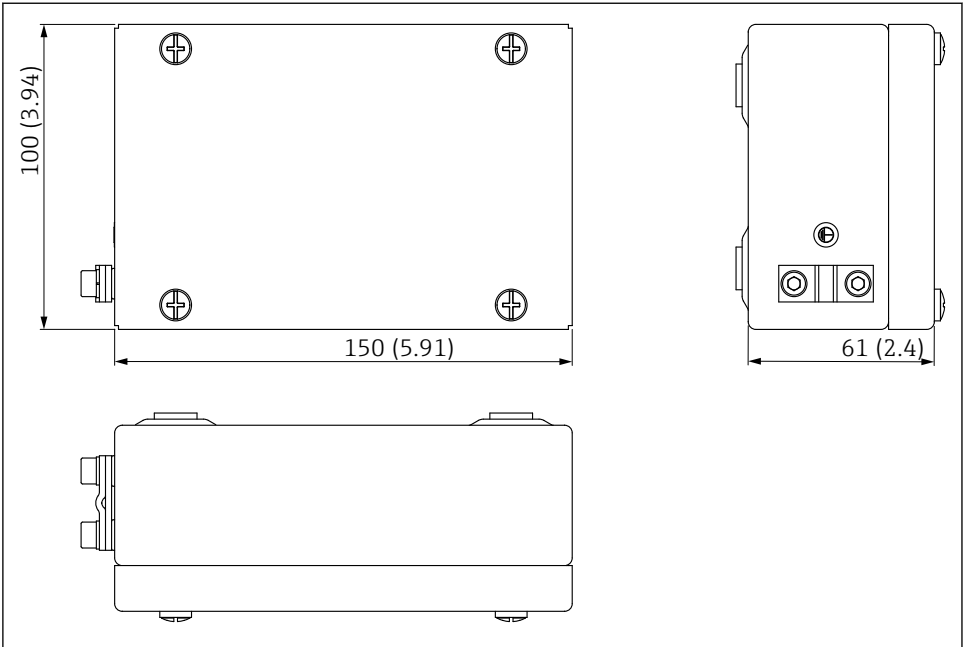

A0053050

4 Dimension of ATEX electronics housing. Unit of measurement mm (in)

5.2.2 Mounting the housing with the remote electronics module

The housing with the remote electronics module can be mounted with two screws (M5).

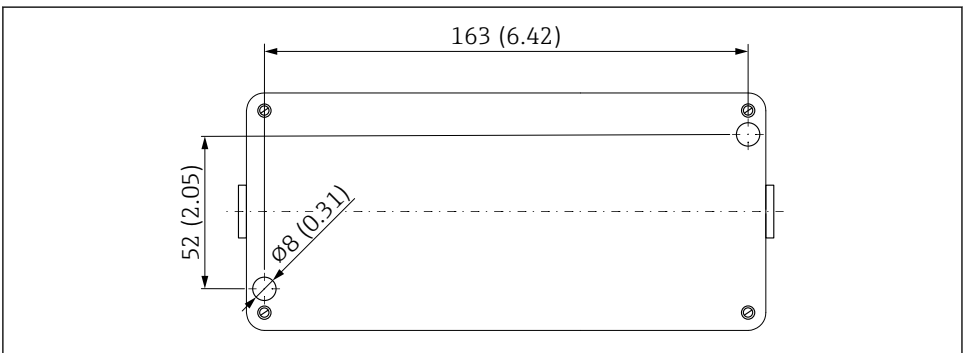

A0046898

5 Mounting stencil for housing with remote electronics module. Unit of measurement mm (in)

5.3 Post-mounting check

Perform the following checks after mounting the device:

- Is the device undamaged (visual inspection)?
- If provided: are the measuring point number and labeling correct?
- Are the connections established correctly and protected against mechanical influences?
- If used: is the device securely positioned in the mounting flange / mounting frame (visual inspection)?
- Is the device securely mounted and is the measuring cell surface flush on the material side (visual inspection)?
- Is sufficient material coverage / material flow over the measurement surface ensured?

6 Electrical connection

6.1 Connecting requirements

6.1.1 Cable specification

Connecting cables with a pre-assembled 10-pin socket on the device side are available in different standard lengths:

- 4 m (13 ft)
- 10 m (32 ft)
- 25 m (82 ft)

Shielded cable **UNITRONIC PUR CP**, twisted pairs $6 \times 2 \times 0.25 \text{ mm}^2$, PUR sheath resistant to oils and chemicals.

On request: Shielded cable **UNITRONIC ROBUST CP** $10 \times 0.25 \text{ mm}^2$, PUR sheath resistant to oils and chemicals.

6.2 Connecting the device

6.2.1 Terminal assignment

The device is supplied as standard with a 10-pin plug, series 26482, with IP67 protection.



In the case of the electronics module located remotely by means of the HF cable, the electronics housing is fitted on both sides with plugs with IP67 protection.

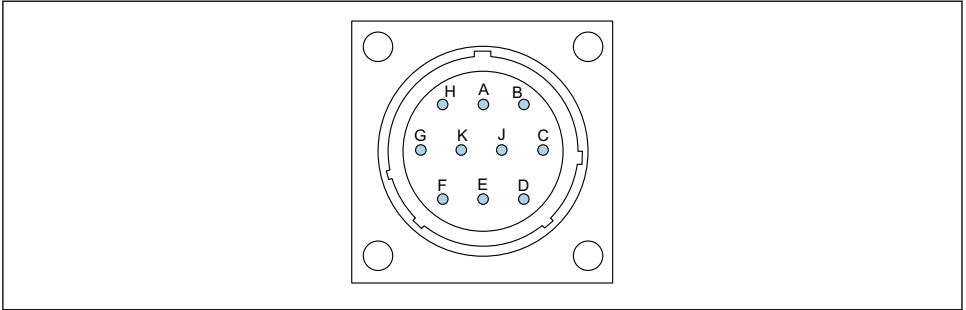

A0037415

6 Assignment of the 10-pin plug

- A 12 to 24 V_{DC} stabilized power supply
Wire color: red (RD)
- B 0 V_{DC} power supply
Wire color: blue (BU)
- D 1st analog positive (+), material moisture
Wire color: green (GN)
- E 1st analog return line (-), material moisture
Wire color: yellow (YE)
- F RS485 A (must be enabled)
Wire color: white (WH)
- G RS485 B (must be enabled)
Wire color: brown (BN)
- C IMP-Bus RT
Wire color: gray (GY) / pink (PK), see figure below
- J IMP-Bus COM
Wire color: blue (BU) / red (RD), see figure below
- K 2nd analog positive (+)
Wire color: pink (PK)
- E 2nd analog return line (-)
Wire color: gray (GY)
- H Shield (is grounded at the device. The installation must be grounded correctly!)
Wire color: transparent

6.3 Post-connection check

- Is the device or cable undamaged (visual inspection)?
- Does the supply voltage match the specifications on the nameplate?
- Are the connections established correctly and protected against mechanical influences?

7 Operation options

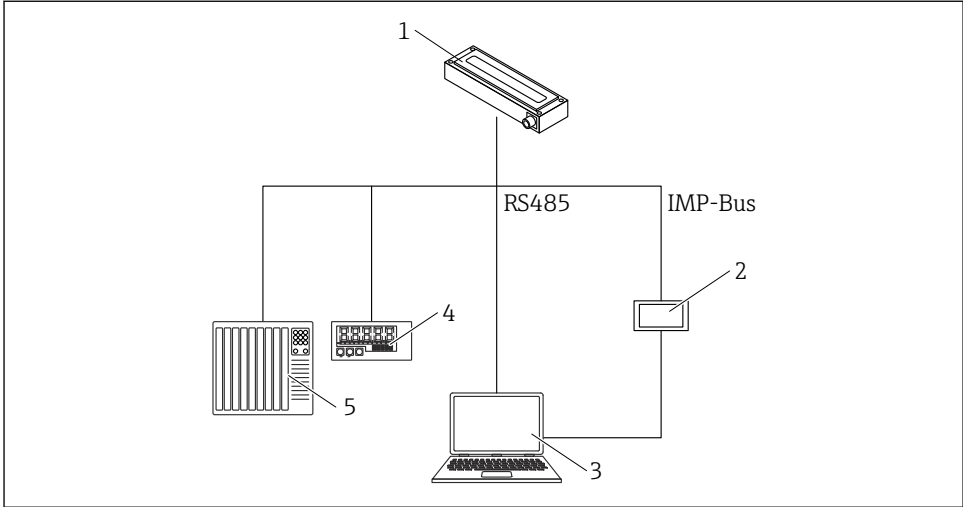

A0046920

7 Overview

- 1 Device
- 2 Remote display
- 3 Computer
- 4 LED display
- 5 PLC or water dosing computer

8 Commissioning

8.1 Analog outputs for measured value output

The measured values are output as a current signal via the analog output. The device can be set to 0 to 20 mA or 4 to 20 mA.

i The current output can also be set inversely to 20 to 0 mA or 20 to 4 mA for special controllers and applications.

The analog outputs can be set differently to the following possible options:

Moisture, temperature

- Output 1: moisture in % (variable setting)
- Output 2: material temperature 0 to 100 °C (32 to 212 °F), this also applies for the high-temperature version.

Moisture, conductivity

- Output 1: moisture in % (variable setting)
- Output 2: conductivity 0 to 20 mS/cm (factory setting)

Moisture, temperature/conductivity

- Output 1: moisture in % (variable setting)
- Output 2: material temperature 0 to 100 °C (32 to 212 °F) and conductivity 0 to 20 mS/cm with automatic window switching.
It is also possible to divide output 2 into two ranges to output both the conductivity and the temperature, namely the 4 to 11 mA range for the temperature and the 12 to 20 mA range for the conductivity. Output 2 automatically switches between these two windows every 5 s.



Output 1 can be scaled at the factory or subsequently scaled as required (variably) using the remote display (optionally available), e.g. 0 to 10 %, 0 to 20 % or 0 to 30 %

8.1.1 Possible settings

There are several possible settings for the analog outputs:

Analog outputs

Options:

- 0 to 20 mA
- 4 to 20 mA



The current output can also be set inversely for special controllers and applications.

- 20 to 0 mA
- 20 to 4 mA

Channels of the analog outputs



The analog outputs can be set differently to the following possible options:

Moisture, temperature

Output 1 for moisture, output 2 for material temperature.

Moisture, conductivity

Output 1 for moisture, output 2 for conductivity in the range from 0 to 20 mS/cm (factory setting)

Moisture, temperature/conductivity

Output 1 for moisture, output 2 for material temperature and conductivity with automatic window switching.

Moisture range

The moisture range and the temperature range at outputs 1 and 2 can be individually configured.

- **Moisture range in %**
 - Maximum: e.g. 20 %
 - Minimum: 0 %
- **Temperature range in °C**
 - Maximum: 100 °C, this also applies for the high-temperature version.
 - Minimum: 0 °C
- **Conductivity in mS/cm**
 - Maximum 20 mS/cm
 - Minimum 0 mS/cm

 The devices can measure the conductivity depending on the device type and the moisture. The output is set to 0 to 20 mS/cm at the factory.

8.2 Operating mode

The device configuration is preset at the factory before the device is delivered. This device setting can then be optimized to suit the process.

Measure mode and parameters:

The following device settings can be changed

- Measure mode C - Cyclic (default setting for devices with cyclic measurement).
- Average time, reaction speed of the measured values
- Calibration (when different materials are used)
- Filter function
- Precision of a single value measurement

 Each of these settings is retained even after the device is switched off, i.e. the setting is saved to the non-volatile memory of the device.

8.2.1 Operating mode

The device is supplied from the factory with the **CH** mode for applications in the construction industry, and with the **CA** mode for general process applications. 6 different operating modes are available in the **C** measuring mode, depending on the application.

- **CS** mode (Cyclic-Successive)
For very short measurement cycles in the seconds range (e.g. 1 to 10 s) without averaging and without filter functions, and with up to 100 measurements per second internally and a cycle time of 250 ms at the analog output.
- **CA** mode (Cyclic Average Filter)
Standard averaging for relatively fast but continuous measurement processes, with simple filtering and an accuracy of up to 0.1 %. The **CA** operating mode is also used to record raw values, without averaging and filtering, to be able to subsequently analyze the measured data and determine the optimum operating mode.
- **CF** mode (Cyclic Floating Average with Filter)
Floating average for very slow and continuous measurement processes, with simple filtering and an accuracy of up to 0.1 %. Suitable for applications on a conveyor belt etc.

- **CK** mode (Cyclic with Boost Filter)
For complex applications in mixers and dryers
- **CC** mode (Cyclic Cumulated)
With automatic totalization of moisture quantity measurements in one batch process if no PLC controller is used
- **CH** mode (Cyclic Hold)
Standard operating mode for applications in the construction industry. Similar to the **CC** mode, but with filtering and without totalization. The **CH** mode is ideal for very short batch times down to 2 s if the sensor has been installed under the silo discharge hatch. The **CH** mode performs filtering automatically. This allows drip water that forms in the silo to be filtered out of the measured value, for example.

8.3 Calibration curve set A for general bulk solids applications

The devices are supplied with a suitable calibration. A maximum of 15 different calibrations can be saved in the device and can be activated and adjusted via the remote display. To pre-test the compatibility of a calibration curve, the user can select individual calibration curves (Cal.1 to Cal.15) in the **Material cal.** menu item, test the curve with the material to be measured and activate it. The desired calibration curve - which may have been modified - is active once the operating voltage is switched on.

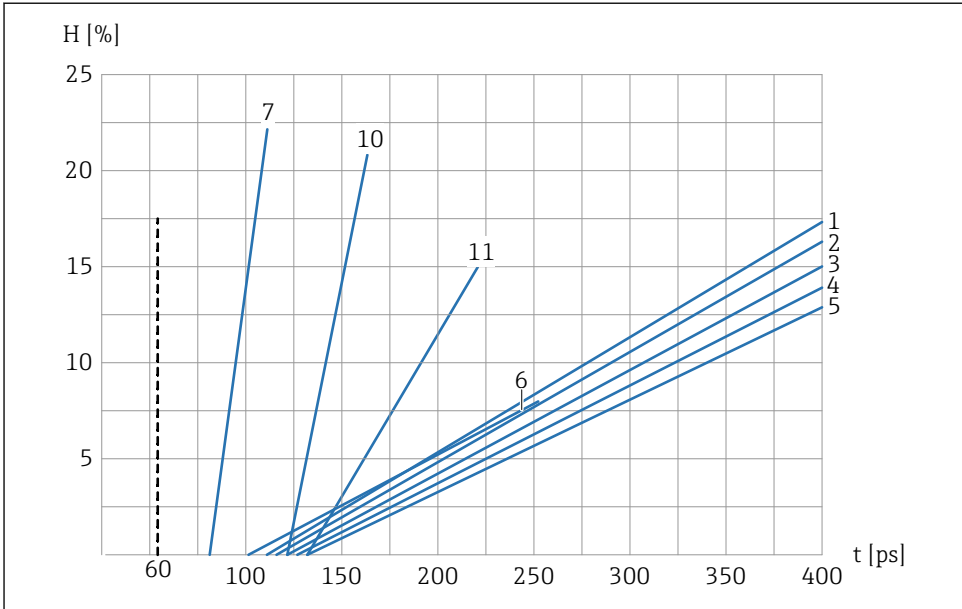

A0037431

8 Calibration curve set A (Cal.1, Cal.2, Cal.3, Cal.4, Cal.5, Cal.6, Cal.7, Cal.10, Cal.11)

H Gravimetric moisture; %

t Radar transit time; picoseconds

1 Cal.1, Universal; sand/gravel/grit

2 Cal.2, Sand 1.6

3 Cal.3, Sand 1.7

4 Cal.4, Sand 1.8

5 Cal.5, Sand 1.9

6 Cal.6, Gravel/grit

7 Cal.7, Wood chips

10 Cal.10, Grains of wheat

11 Cal.11, Light sand

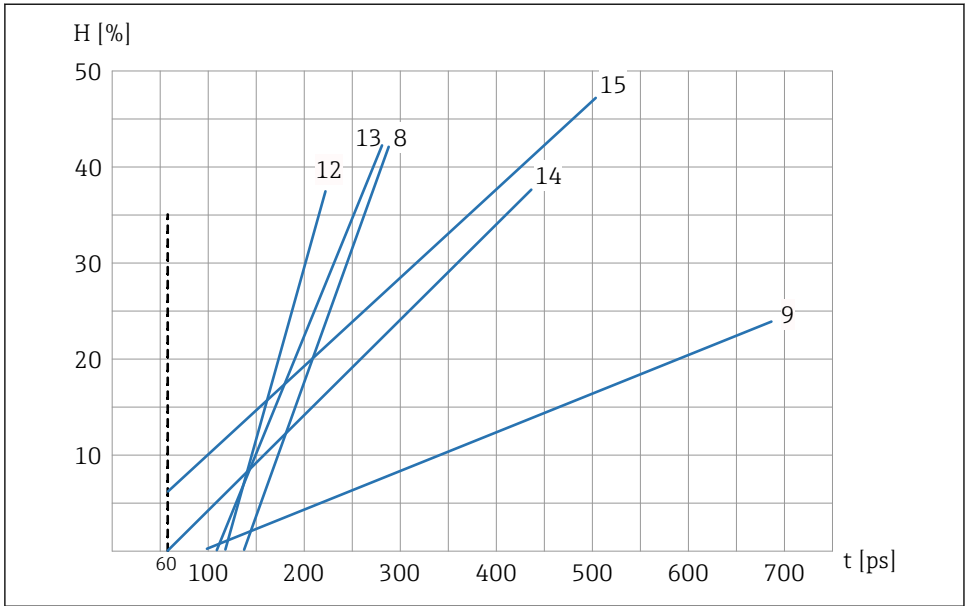

A0037432

9 Calibration curve set A (Cal.8, Cal.9, Cal.12, Cal.13, Cal.14, Cal.15)

H Gravimetric moisture; %

t Radar transit time; picoseconds

8 Cal.8, Lignite

9 Cal.9, Basic calibration

12 Cal.12, Sewage sludge

13 Cal.13, Cereals (linear)

14 Cal.14, Air/water 0 to 100 %

15 Cal.15, Raw data calibration ($1/10$ of average radar transit time)

The graphics show the linear calibration curves (Cal.1 to Cal.15) for various materials that are saved and can be selected in the device. The gravimetric moisture (*H*) is indicated as a percentage on the y-axis, and the associated radar transit time (*t*) in picoseconds is indicated on the x-axis. The radar transit time is displayed simultaneously with the moisture value during moisture measurement. In air, the devices measure approx. 60 ps radar transit time, and 1000 ps in water.

8.4 Settings

8.4.1 Material calibration

In the **Material calibration** menu item, the necessary calibration can be selected via the optional remote display, depending on the application. In this way, one device can cover a range of different applications.

It is also possible to perform your own calibrations and overwrite an existing calibration curve.

 SD02333M **Remote display** - Description of operation and material calibration.

8.5 Special functions

Special functions that are available are described in the Operating Instructions pertaining to the device.

9 Diagnostics and troubleshooting

The device is normally precalibrated with calibration set B and Cal.14 (air/water 0 to 100 %) upon delivery.

Fine-tuning to achieve an accuracy of ± 0.1 % in relation to the laboratory value can be performed via a PLC or the remote display (optional).

Fine-tuning with the PLC

Depending on the PLC, it is possible to perform a parallel shift/offset in the PLC. The parameter has different names depending on the PLC (e.g. initial load, zero point, offset, measuring range, etc.).

- ▶ Perform a parallel shift / offset in the PLC
 - ↳ Contact the PLC manufacturer

Fine-tuning with the remote display

- ▶ Perform fine-tuning / parallel shift in the device via the **Offset** parameter

9.1 Different moisture value

If the moisture value of the device deviates by more than ± 1 % from the laboratory value during initial commissioning, this may be due to the following:

Incorrect installation in the material flow

The measurement surface must be sufficiently covered. A good, stable flow of material **must** be guaranteed.

- ▶ Correct the installation or material flow
 - ↳ A video of the material flow during the batch process can be helpful for analysis purposes.

The wrong calibration curve is set

The device is delivered with calibration curve Cal.14 (air / water 0 to 100 %).

- ▶ Select a suitable calibration curve.

Moisture scaling set incorrectly in the PLC

In the device, 0 to 20 % moisture corresponds to the current output of 0 to 20 mA or 4 to 20 mA.

- ▶ Enter the 0 to 20 % moisture scaling in the PLC.
 - ↳ Contact the PLC manufacturer

The calibration curves that are saved do not match the material

In the case of materials where the slope does not roughly correspond to a calibration curve saved in the device, a 2-point calibration (dry and wet material sample) may be necessary in the PLC or sensor.

- ▶  SD02333M **Remote display** - Description of operation and material calibration

Moisture value too high

In the case of coarse-grained or hydrophobic materials, water can escape directly onto the measurement surface and therefore cause a high moisture value.

- ▶ Enter limit values in the PLC.
 - ↳ Contact the PLC manufacturer

Incorrect data processing

In the event of inaccurate data processing, check the moisture value displayed in the PLC.

1. Connect the device to the remote display
2. Compare the moisture value shown in the PLC with the moisture value shown on the display
3. For a test run, set the **CS** operating mode in the device
4. After the test run, set the operating mode back to **CA**

Start/stop conditions are not correct

- Start condition: time in seconds or kg in the scales
- Stop condition: usually % of target weight
- ▶ Check the start/stop conditions in the PLC
 - ↳ Contact the PLC manufacturer



If the solutions described here do not rectify the problem, contact the manufacturer's Service Department.



71624865

www.addresses.endress.com
