

Operating Instructions

Liquiphant FTL51B Density

Vibronic

Density measurement for liquids





A0023555

Table of contents

| | | | | | |
|----------|---|-----------|-----------|--|-----------|
| 1 | About this document | 5 | 6 | Electrical connection | 20 |
| 1.1 | Purpose of this document | 5 | 6.1 | Required tool | 20 |
| 1.2 | Symbols | 5 | 6.2 | Connecting requirements | 20 |
| 1.2.1 | Safety symbols | 5 | 6.2.1 | Cover with securing screw | 20 |
| 1.2.2 | Electrical symbols | 5 | 6.2.2 | Connecting protective earth (PE) | 21 |
| 1.2.3 | Tool symbols | 5 | 6.3 | Connecting the device | 21 |
| 1.2.4 | Symbols for certain types of information | 5 | 6.3.1 | 2-wire density (electronic insert FEL60D) for density measurement | 21 |
| 1.2.5 | Symbols in graphics | 6 | 6.3.2 | Connecting the cables | 23 |
| 1.3 | Documentation | 6 | 6.3.3 | Post-connection check | 24 |
| 1.3.1 | Standard documentation | 6 | 7 | Operation options | 25 |
| 1.3.2 | Supplementary device-dependent documentation | 6 | 7.1 | Overview of operation options | 25 |
| 2 | Basic safety instructions | 6 | 7.1.1 | Operating concept | 25 |
| 2.1 | Requirements for the personnel | 6 | 7.1.2 | Elements on the electronic insert | 25 |
| 2.2 | Intended use | 7 | 8 | Commissioning | 25 |
| 2.2.1 | Incorrect use | 7 | 8.1 | Function check | 25 |
| 2.3 | Workplace safety | 7 | 8.2 | Switching on the device | 25 |
| 2.4 | Operational safety | 7 | 9 | Operation | 26 |
| 2.5 | Product safety | 8 | 9.1 | Light signals | 26 |
| 2.6 | IT security | 8 | 10 | Diagnostics and troubleshooting | 26 |
| 3 | Product description | 8 | 10.1 | Diagnostic information via light emitting diodes | 26 |
| 3.1 | Product design | 9 | 10.1.1 | LED at electronic insert | 26 |
| 4 | Incoming acceptance and product identification | 9 | 10.2 | Firmware history | 27 |
| 4.1 | Incoming acceptance | 9 | 11 | Maintenance | 27 |
| 4.2 | Product identification | 10 | 11.1 | Maintenance tasks | 27 |
| 4.2.1 | Nameplate | 10 | 11.1.1 | Cleaning | 27 |
| 4.2.2 | Manufacturer address | 10 | 12 | Repair | 27 |
| 4.3 | Storage and transport | 10 | 12.1 | General notes | 27 |
| 4.3.1 | Storage conditions | 10 | 12.1.1 | Repair concept | 27 |
| 5 | Mounting | 11 | 12.1.2 | Repairs to Ex-approved devices | 27 |
| 5.1 | Mounting requirements | 11 | 12.2 | Spare parts | 28 |
| 5.1.1 | Flow velocity - Installation in piping | 12 | 12.3 | Return | 28 |
| 5.1.2 | Inlet and outlet runs | 12 | 12.4 | Disposal | 28 |
| 5.1.3 | Correction factor | 13 | 13 | Accessories for Liquiphant Density | 28 |
| 5.1.4 | Avoid buildup | 16 | 13.1 | Protective cover for aluminum dual compartment housing | 28 |
| 5.1.5 | Take clearance into consideration | 16 | 13.2 | Protective cover for single compartment housing, aluminum or 316L | 29 |
| 5.1.6 | Support the device | 16 | 13.3 | M12 socket | 29 |
| 5.1.7 | Weld-in adapter with leakage hole | 17 | 13.4 | Weld-in adapter | 30 |
| 5.2 | Mounting the device | 17 | | | |
| 5.2.1 | Required tool | 17 | | | |
| 5.2.2 | Installation | 18 | | | |
| 5.3 | Sliding sleeves | 20 | | | |
| 5.4 | Post-mounting check | 20 | | | |

| | | |
|-----------|---|-----------|
| 14 | Accessories for Density Computer | |
| | FML621 | 30 |
| 14.1 | General | 30 |
| 14.2 | Extension cards | 31 |
| 14.3 | PROFINET® Interface | 31 |
| 15 | Technical data | 31 |
| 15.1 | Input | 31 |
| | 15.1.1 Measured variable | 31 |
| | 15.1.2 Measuring range | 32 |
| 15.2 | Output | 32 |
| | 15.2.1 Output and input variants | 32 |
| | 15.2.2 Ex connection data | 32 |
| 15.3 | Environment | 32 |
| | 15.3.1 Ambient temperature range | 32 |
| | 15.3.2 Storage temperature | 32 |
| | 15.3.3 Operating altitude | 32 |
| | 15.3.4 Climate class | 32 |
| | 15.3.5 Degree of protection | 32 |
| | 15.3.6 Pollution degree | 33 |
| 15.4 | Process | 33 |
| | 15.4.1 Process temperature range | 33 |
| | 15.4.2 Thermal shock | 33 |
| | 15.4.3 Process pressure range | 33 |
| | 15.4.4 Pressure tightness | 33 |
| 15.5 | Additional technical data | 34 |
| | Index | 35 |

1 About this document

1.1 Purpose of this document

These Operating Instructions contain all the information that is required in the various phases of the life cycle of the device: from product identification, incoming acceptance and storage, to mounting, connection, operation and commissioning through to troubleshooting, maintenance and disposal.

1.2 Symbols

1.2.1 Safety symbols

DANGER

This symbol alerts you to a dangerous situation. Failure to avoid this situation will result in serious or fatal injury.

WARNING

This symbol alerts you to a dangerous situation. Failure to avoid this situation can result in serious or fatal injury.

CAUTION

This symbol alerts you to a dangerous situation. Failure to avoid this situation can result in minor or medium injury.

NOTICE

This symbol contains information on procedures and other facts which do not result in personal injury.

1.2.2 Electrical symbols

 Ground connection

Grounded clamp, which is grounded via a grounding system.

 Protective earth (PE)

Ground terminals, which must be grounded prior to establishing any other connections. The ground terminals are located on the inside and outside of the device.

1.2.3 Tool symbols

 Flat-blade screwdriver

 Allen key

 Open-ended wrench

1.2.4 Symbols for certain types of information

 Permitted

Procedures, processes or actions that are permitted.

 Forbidden

Procedures, processes or actions that are forbidden.

 Tip

Indicates additional information

 Reference to documentation

 Reference to another section

1, 2, 3 Series of steps

1.2.5 Symbols in graphics

A, B, C ... View

1, 2, 3 ... Item numbers

 Hazardous area

 Safe area (non-hazardous area)

1.3 Documentation

 For an overview of the scope of the associated Technical Documentation, refer to the following:

- *Device Viewer* (www.endress.com/deviceviewer): Enter the serial number from the nameplate
- *Endress+Hauser Operations app*: Enter serial number from nameplate or scan matrix code on nameplate.

1.3.1 Standard documentation

Document type: Operating Instructions (BA)

Installation and initial commissioning – contains all the functions in the operating menu that are needed for a normal measuring task. Functions beyond this scope are not included.

Document type: Brief Operating Instructions (KA)

Quick guide to the first measured value – includes all essential information from incoming acceptance to electrical connection.

Document type: Safety Instructions, certificates

Depending on the approval, Safety Instructions are also supplied with the device, e.g. XA. This documentation is an integral part of the Operating Instructions. The nameplate indicates the Safety Instructions (XA) that are relevant to the device.

1.3.2 Supplementary device-dependent documentation

Operating Instructions

BA00335F: Density Computer FML621

Special Documentation

- SD01622P: Weld-in adapter (installation instructions)
- TI00426F: Weld-in adapters, process adapters and flanges (overview)

2 Basic safety instructions



2.1 Requirements for the personnel

The personnel must fulfill the following requirements to carry out the necessary tasks, e. g., commissioning and maintenance:

- ▶ Trained, qualified specialists must have a relevant qualification for the specific function and task
- ▶ Are authorized by the plant owner/operator
- ▶ Are familiar with federal/national regulations

- ▶ Must have read and understood the instructions in the manual and supplementary documentation
- ▶ Follow instructions and comply with conditions

2.2 Intended use

- Use the device only for measuring the density of liquids.
- Improper use can pose hazards
- Ensure that the device is free of defects while it is in operation
- Use the device only for media to which the wetted materials have an adequate level of resistance
- Do not exceed or drop below the relevant limit values for the device
 -  For more details, see the "Technical data" section
 -  See the Technical Documentation

2.2.1 Incorrect use

The manufacturer is not liable for damage caused by improper or non-intended use.

Residual risks

Due to heat transfer from the process, the temperature of the electronics housing and the assemblies contained therein may rise to 80 °C (176 °F) during operation.

Danger of burns from contact with surfaces!

- ▶ If necessary, ensure protection against contact to prevent burns.

2.3 Workplace safety

For work on and with the device:

- ▶ Wear the required personal protective equipment according to federal/national regulations.

2.4 Operational safety

Risk of injury!

- ▶ Operate the device only if it is in proper technical condition, free from errors and faults.
- ▶ The operator is responsible for ensuring the interference-free operation of the device.

Modifications to the device

Unauthorized modifications to the device are not permitted and can lead to unforeseeable dangers.

- ▶ If, despite this, modifications are required, consult with Endress+Hauser.

Repair

To ensure continued operational safety and reliability:

- ▶ Only perform repair work on the device if this is expressly permitted.
- ▶ Observe federal/national regulations pertaining to the repair of an electrical device.
- ▶ Use original spare parts and accessories from Endress+Hauser only.

Hazardous area

To eliminate danger to persons or the facility when the device is used in the hazardous area (e.g. explosion protection):

- ▶ Check the nameplate to verify whether the ordered device can be used for the intended purpose in the hazardous area.

- ▶ Observe the specifications in the separate supplementary documentation that is an integral part of this manual.

2.5 Product safety

This device is designed in accordance with good engineering practice to meet state-of-the-art safety requirements, has been tested, and left the factory in a condition in which it is safe to operate.

It meets the general safety standards and legal requirements. It also complies with the EU directives listed in the device-specific EU Declaration of Conformity. Endress+Hauser confirms this by affixing the CE mark to the device.

2.6 IT security

We only provide a warranty if the device is installed and used as described in the Operating Instructions. The device has safety mechanisms integrated to prevent users from inadvertently changing settings.

Provide additional protection for the device and data transfer to/from the device

- ▶ IT security measures defined in the plant owner/operator's own security policy must be implemented by plant owners/operators themselves.

3 Product description

Liquiphant FTL51B sensor with electronic insert FEL60D

For measuring the density of liquid media in conjunction with density computer FML621. Also suitable for use in hazardous areas.

3.1 Product design

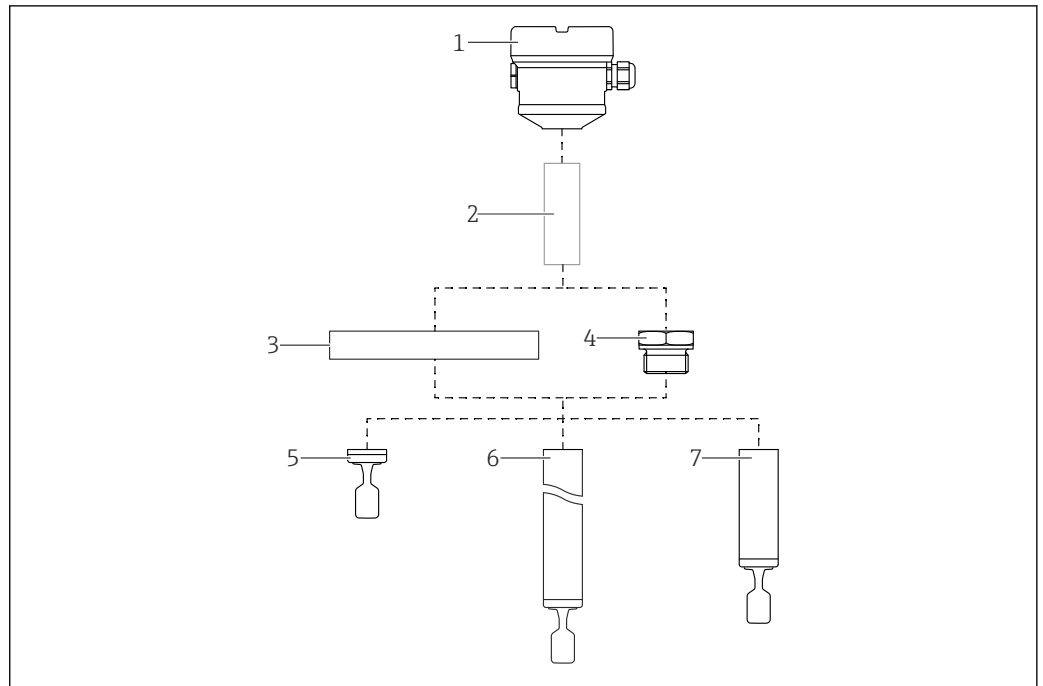

A0046337

 1 Product design: Liquiphant FTL51B

- 1 Housing with electronic insert FEL60D and cover
- 2 Temperature spacer, pressure-tight feedthrough (second line of defense), optional
- 3 Process connection with flange (optional)
- 4 Process connection with thread (optional)
- 5 Compact probe version with tuning fork
- 6 Pipe extension probe with tuning fork
- 7 Short tube version of probe with tuning fork

4 Incoming acceptance and product identification

4.1 Incoming acceptance

Check the following during incoming acceptance:

- Are the order codes on the delivery note and the product sticker identical?
- Are the goods undamaged?
- Do the data on the nameplate match the ordering information on the delivery note?
- If required (see nameplate): are the Safety Instructions e.g. XA provided?
-  If one of these conditions is not met, please contact the manufacturer's sales office.

4.2 Product identification

The following options are available for identification of the device:

- Nameplate specifications
- Extended order code with breakdown of the device features on the delivery note
- Enter serial number from nameplates in *W@M Device Viewer* www.endress.com/deviceviewer. All of the information on the measuring device is displayed along with an overview of the scope of technical documentation provided.
- Enter the serial number on the nameplate into the *Endress+Hauser Operations app* or scan the 2-D matrix code on the nameplate with the *Endress+Hauser Operations app*

4.2.1 Nameplate

The information that is required by law and is relevant to the device is shown on the nameplate, e.g.:

- Manufacturer identification
- Order number, extended order code, serial number
- Technical data, degree of protection
- Firmware version, hardware version
- Approval-related information, reference to Safety Instructions (XA)
- DataMatrix code (information about the device)

4.2.2 Manufacturer address

Endress+Hauser SE+Co. KG
Hauptstraße 1
79689 Maulburg, Germany
Place of manufacture: See nameplate.

4.3 Storage and transport

4.3.1 Storage conditions

Use original packaging.

Storage temperature

-40 to +80 °C (-40 to +176 °F)

Transporting the device

- Transport the device to the measuring point in the original packaging
- Hold the device by the housing, temperature spacer, process connection or extension pipe
- Do not bend, shorten or extend the tuning fork

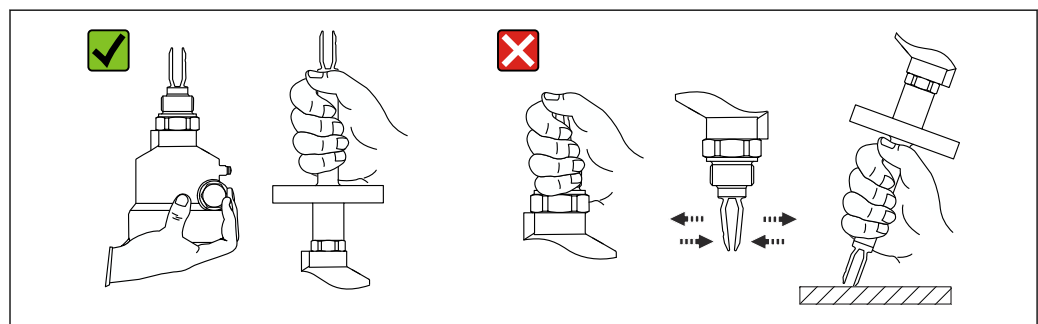

2 Handling the device during transport

A0034846

5 Mounting

Mounting instructions

- Any orientation for compact version or version with a pipe length of up to 500 mm (19.7 in) approx.
- Vertical orientation from above for device with long pipe
- Minimum distance between the fork tip and the tank wall or pipe wall: 10 mm (0.39 in)

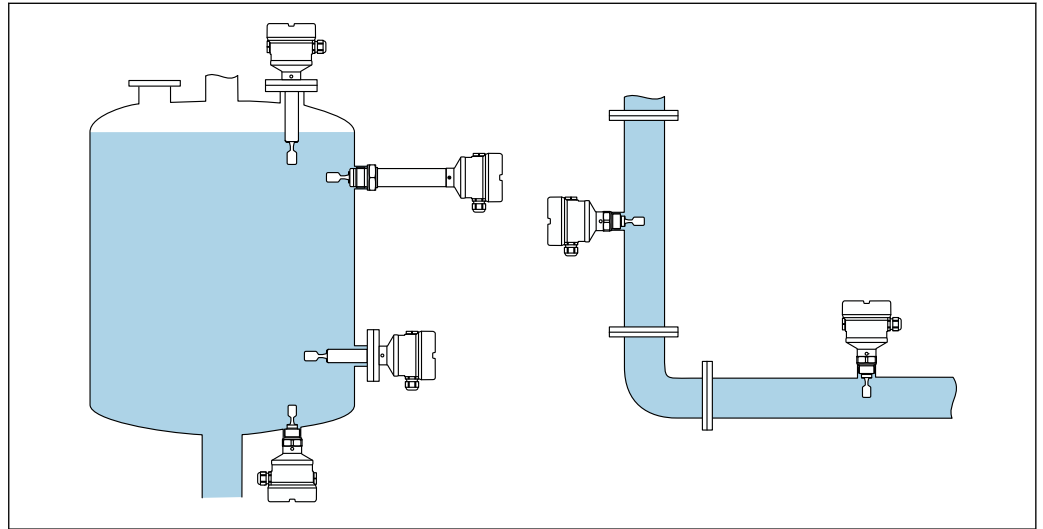

3 Installation examples for a vessel, tank or pipe

A0039739

5.1 Mounting requirements

The mounting location must be selected such that the tuning fork and the membrane are always immersed in the medium.

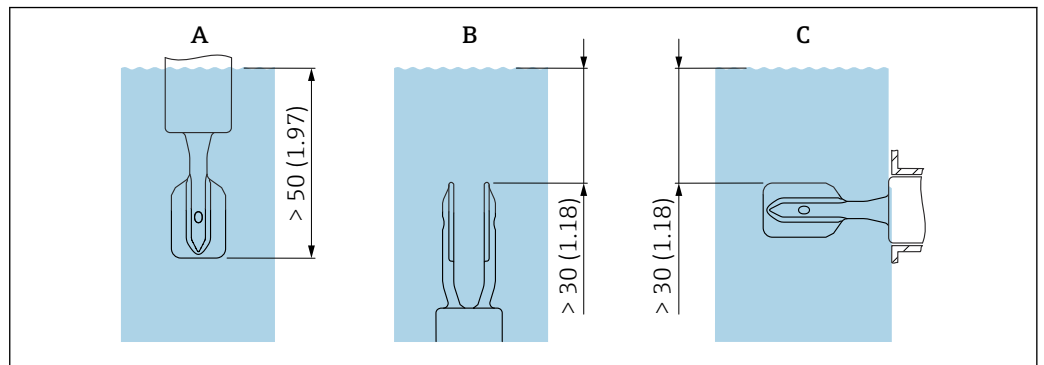

4 Unit mm (in)

A0039685

- A Installation from above
- B Installation from below
- C Installation from the side



- Avoid air bubbles in pipe or nozzle
- Ensure suitable ventilation

5.1.1 Flow velocity - Installation in piping

Install the tuning fork within the medium flow

- Flow velocity: < 2 m/s (6.56 ft/s) per second
- Prevents the formation of air bubbles (1)

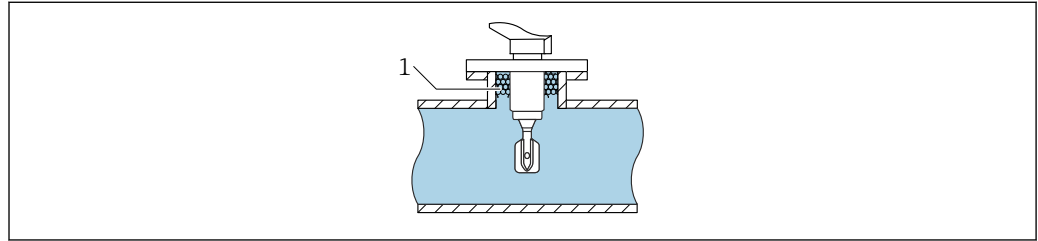

A0039718

5 Installation example in pipes within the media flow

Install the tuning fork away from the direct flow of medium

Flow velocity: < 2 m/s (6.56 ft/s)

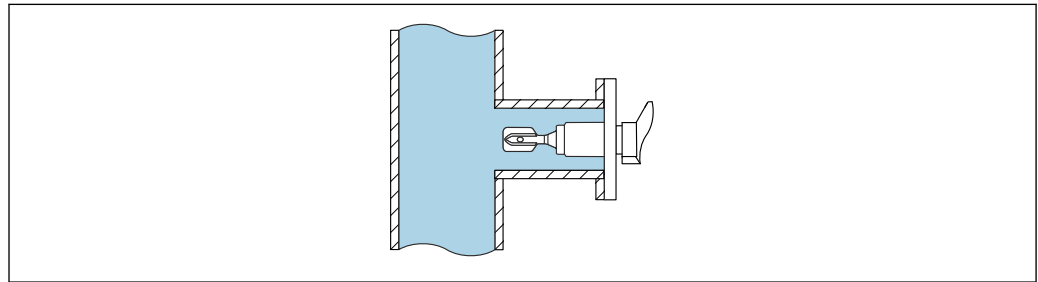

A0039721

6 Installation example in pipes away from the direct flow of medium

5.1.2 Inlet and outlet runs

Inlet run

If possible, install the sensor as far upstream as possible, e.g. valves, T-pieces, elbows, flange elbows, etc.

To comply with the accuracy specification, the inlet run must meet the following requirements:

Inlet run: $\geq 5x$ DN (nominal diameter) - min. 750 mm (29.5 in)

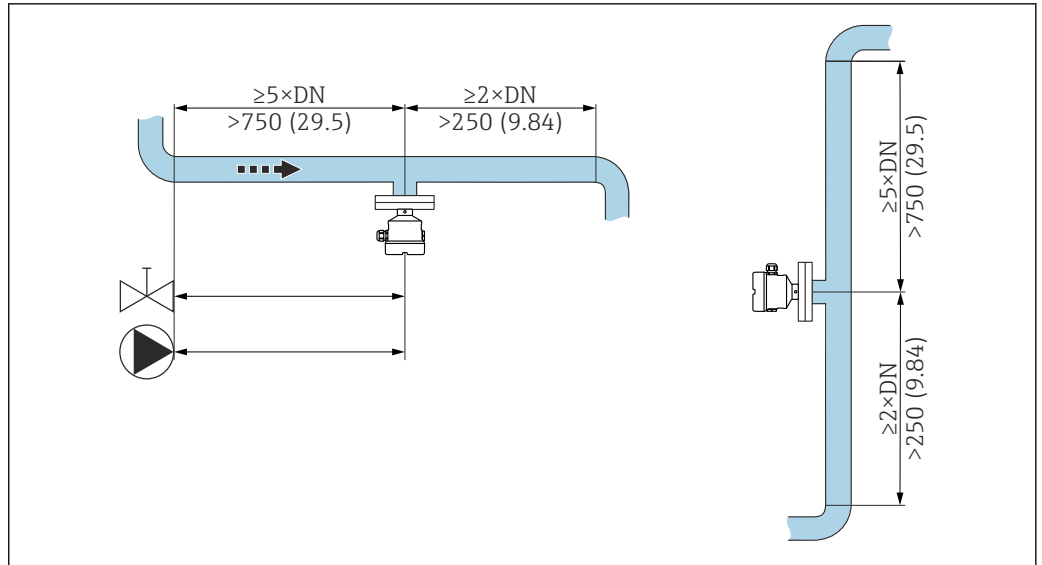

7 Installing the inlet run. Unit of measurement mm (in)

Outlet run

To comply with the accuracy specification, the outlet run must meet the following requirements:

Outlet run: $\geq 2 \times \text{DN}$ (nominal diameter) - min. 250 mm (9.84 in)

The pressure and temperature sensor must be installed on the outlet side of the flow direction after the Liquiphant density sensor. When installing pressure and temperature measuring points downstream of the device, make sure the distance between the measuring point and the measuring device is sufficient.

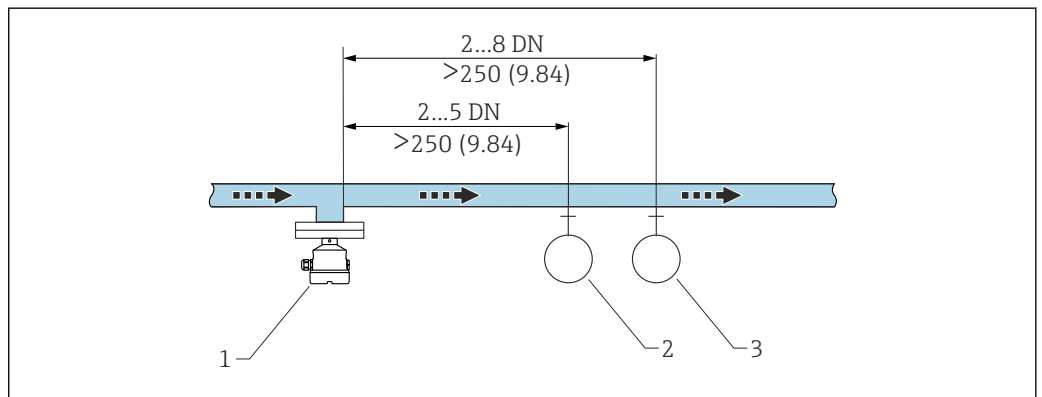

8 Installing the outlet run. Unit of measurement mm (in)

- 1 Liquiphant density sensor
- 2 Pressure measuring point
- 3 Temperature measuring point

5.1.3 Correction factor

If the vibration of the tuning fork is affected by conditions at the mounting location, the measurement result can be adjusted using a correction factor (r).

Standard installation

Correction factor "r" as a factor of height "h", for entering in the Density Computer FML621 or ReadWin2000:

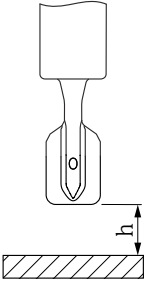
| | h | r |
|--|-----------------|--------|
|  <small>A0039687</small> | 12 mm (0.47 in) | 1.0026 |
| | 14 mm (0.55 in) | 1.0016 |
| | 16 mm (0.63 in) | 1.0011 |
| | 18 mm (0.71 in) | 1.0008 |
| | 20 mm (0.79 in) | 1.0006 |
| | 22 mm (0.87 in) | 1.0005 |
| | 24 mm (0.94 in) | 1.0004 |
| | 26 mm (1.02 in) | 1.0004 |
| | 28 mm (1.10 in) | 1.0004 |
| | 30 mm (1.18 in) | 1.0003 |
| | 32 mm (1.26 in) | 1.0003 |
| | 34 mm (1.34 in) | 1.0002 |
| | 36 mm (1.42 in) | 1.0001 |
| | 38 mm (1.50 in) | 1.0001 |
| | 40 mm (1.57 in) | 1.0000 |

Installation in a bypass

Correction factor "r" as a factor of the internal diameter of bypass "D", for entering in the Density Computer FML621 or ReadWin2000:

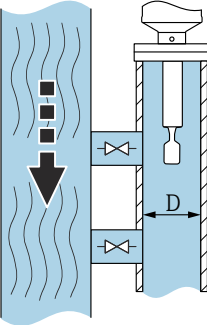
| | D | r |
|--|------------------|--------|
|  <small>A0039689</small> | <44 mm (1.73 in) | - |
| | 44 mm (1.73 in) | 1.0191 |
| | 46 mm (1.81 in) | 1.0162 |
| | 48 mm (1.89 in) | 1.0137 |
| | 50 mm (1.97 in) | 1.0116 |
| | 52 mm (2.05 in) | 1.0098 |
| | 54 mm (2.13 in) | 1.0083 |
| | 56 mm (2.20 in) | 1.0070 |
| | 58 mm (2.28 in) | 1.0059 |
| | 60 mm (2.36 in) | 1.0050 |
| | 62 mm (2.44 in) | 1.0042 |
| | 64 mm (2.52 in) | 1.0035 |
| | 66 mm (2.60 in) | 1.0030 |
| | 68 mm (2.68 in) | 1.0025 |
| | 70 mm (2.76 in) | 1.0021 |
| | 72 mm (2.83 in) | 1.0017 |
| | 74 mm (2.91 in) | 1.0014 |
| | 76 mm (2.99 in) | 1.0012 |
| | 78 mm (3.07 in) | 1.0010 |

| | D | r |
|--|-------------------|--------|
| | 80 mm (3.15 in) | 1.0008 |
| | 82 mm (3.23 in) | 1.0006 |
| | 84 mm (3.31 in) | 1.0005 |
| | 86 mm (3.39 in) | 1.0004 |
| | 88 mm (3.46 in) | 1.0003 |
| | 90 mm (3.54 in) | 1.0003 |
| | 92 mm (3.62 in) | 1.0002 |
| | 94 mm (3.70 in) | 1.0002 |
| | 96 mm (3.78 in) | 1.0001 |
| | 98 mm (3.86 in) | 1.0001 |
| | 100 mm (3.94 in) | 1.0001 |
| | >100 mm (3.94 in) | 1.0000 |

Installation in pipe

Correction factor "r" as a factor of the internal diameter of pipe "D", for entering in the Density Computer FML621 or ReadWin2000:

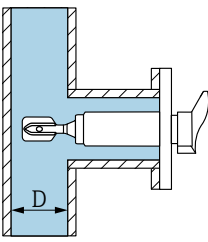
| | D | r |
|---|------------------|--------|
|  <p>A0039707</p> | <44 mm (1.73 in) | - |
| | 44 mm (1.73 in) | 1.0225 |
| | 46 mm (1.81 in) | 1.0167 |
| | 48 mm (1.89 in) | 1.0125 |
| | 50 mm (1.97 in) | 1.0096 |
| | 52 mm (2.05 in) | 1.0075 |
| | 54 mm (2.13 in) | 1.0061 |
| | 56 mm (2.20 in) | 1.0051 |
| | 58 mm (2.28 in) | 1.0044 |
| | 60 mm (2.36 in) | 1.0039 |
| | 62 mm (2.44 in) | 1.0035 |
| | 64 mm (2.52 in) | 1.0032 |
| | 66 mm (2.60 in) | 1.0028 |
| | 68 mm (2.68 in) | 1.0025 |
| | 70 mm (2.76 in) | 1.0022 |
| | 72 mm (2.83 in) | 1.0020 |
| | 74 mm (2.91 in) | 1.0017 |
| | 76 mm (2.99 in) | 1.0015 |
| | 78 mm (3.07 in) | 1.0012 |
| | 80 mm (3.15 in) | 1.0009 |
| 82 mm (3.23 in) | 1.0007 | |
| 84 mm (3.31 in) | 1.0005 | |
| 86 mm (3.39 in) | 1.0004 | |
| 88 mm (3.46 in) | 1.0003 | |
| 90 mm (3.54 in) | 1.0002 | |

| | D | r |
|--|-------------------|--------|
| | 92 mm (3.62 in) | 1.0002 |
| | 94 mm (3.70 in) | 1.0001 |
| | 96 mm (3.78 in) | 1.0001 |
| | 98 mm (3.86 in) | 1.0001 |
| | 100 mm (3.94 in) | 1.0001 |
| | >100 mm (3.94 in) | 1.0000 |

5.1.4 Avoid buildup

NOTICE

The presence of buildup or corrosion on the tuning fork affects the result of the measurement and must be avoided!

- ▶ Allow for maintenance intervals if required!

5.1.5 Take clearance into consideration

Allow sufficient space outside the tank for mounting, connection and replacement of the electronic insert.

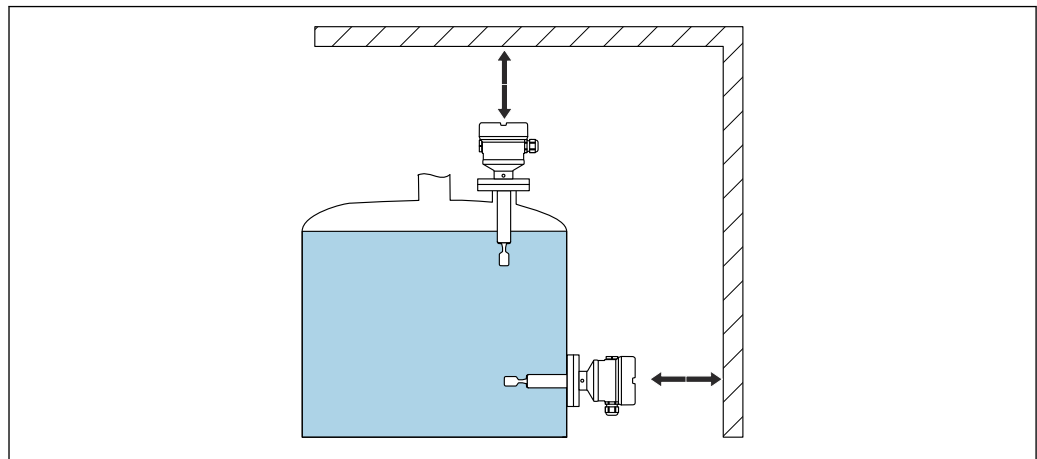

9 Take clearance into consideration

A0039741

5.1.6 Support the device

Support the device in the event of severe dynamic load. Maximum lateral loading capacity of the pipe extensions and sensors: 75 Nm (55 lbf ft).

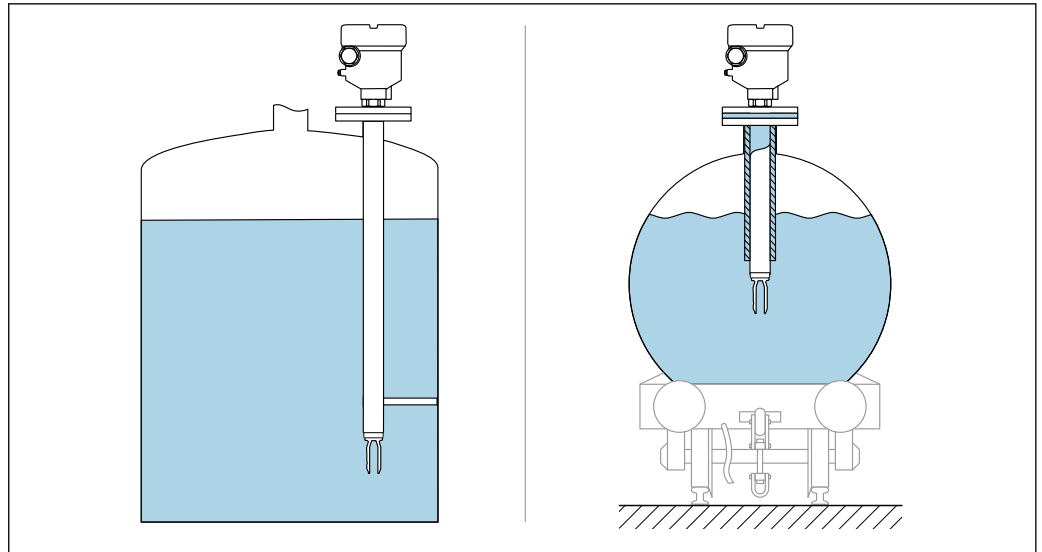

A0039742

10 Examples of support in the event of dynamic load

5.1.7 Weld-in adapter with leakage hole

Weld in the weld-in adapter in such a way that the leakage hole is pointing downwards. This enables any leaks to be detected quickly.

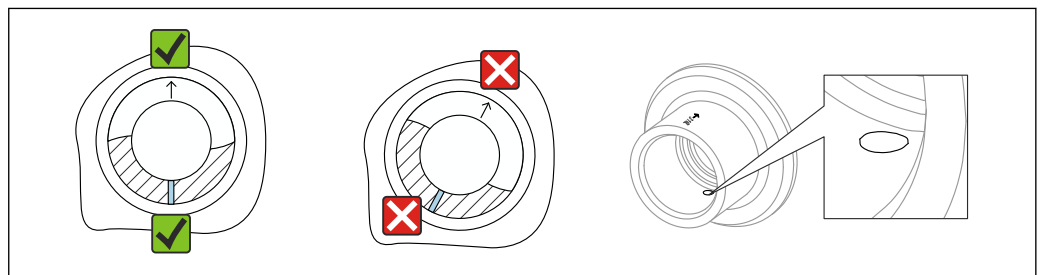

A0039230

11 Weld-in adapter with leakage hole

5.2 Mounting the device

5.2.1 Required tool

- Open-ended wrench for sensor installation
- Allen key for housing locking screw

5.2.2 Installation

Aligning the tuning fork using the marking

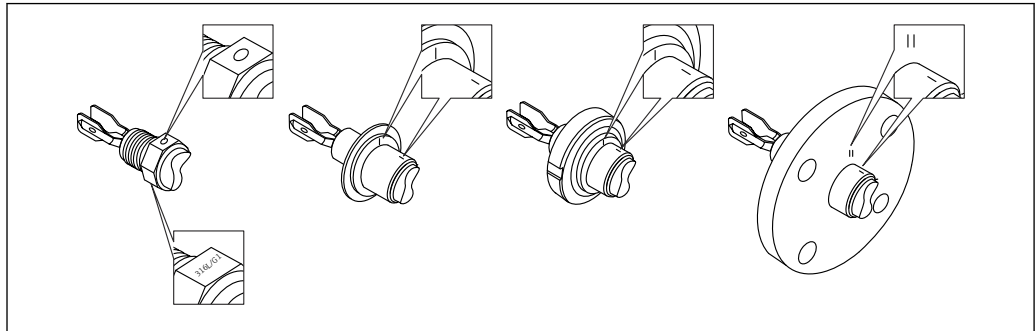

A0039125

12 Position of the tuning fork when installed horizontally in the vessel using the marking

Installing the device in piping

NOTICE

Incorrect alignment of the tuning fork

Vortices and eddies can falsify the measuring result.

- ▶ Align the tuning fork in the flow direction for internal fixtures in pipes or tanks with an agitator.
 - The flow velocity of the medium must not exceed 2 m/s (6.56 ft/s) during operation
 - Flow velocity > 2 m/s: Separate the tuning fork from the direct flow of media by using structural features such as a bypass or pipe expansion to reduce the flow velocity to max. 2 m/s (6.56 ft/s)
 - The flow will not be significantly impeded if the tuning fork is correctly aligned and the marking is pointing in the direction of flow.
 - A marking on the process connection indicates the position of the tuning fork. Threaded connection = dot on the hexagon head; flange = two lines on the flange. The marking is visible when installed.

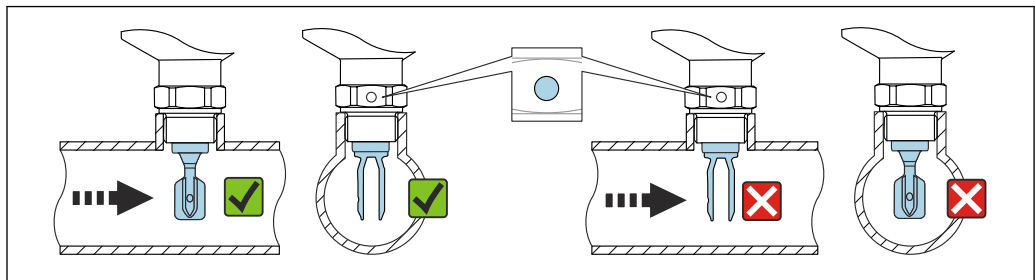

A0034851

13 Installation in pipes (take fork position and marking into consideration)

Screwing in the device

- Turn by the hex bolt only, 15 to 30 Nm (11 to 22 lbf ft)
- Do not turn at the housing!

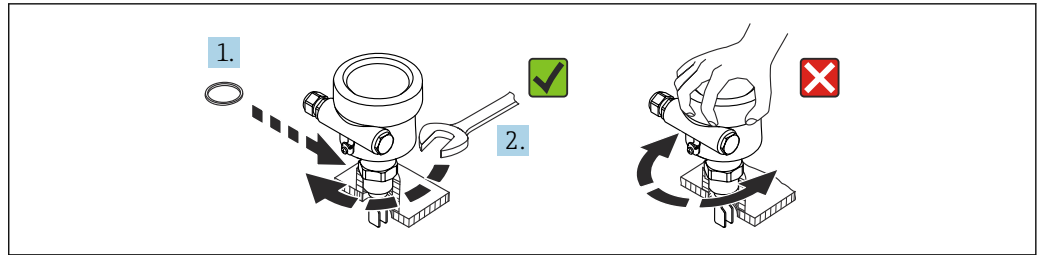

14 Screwing in the device

Aligning the cable entry

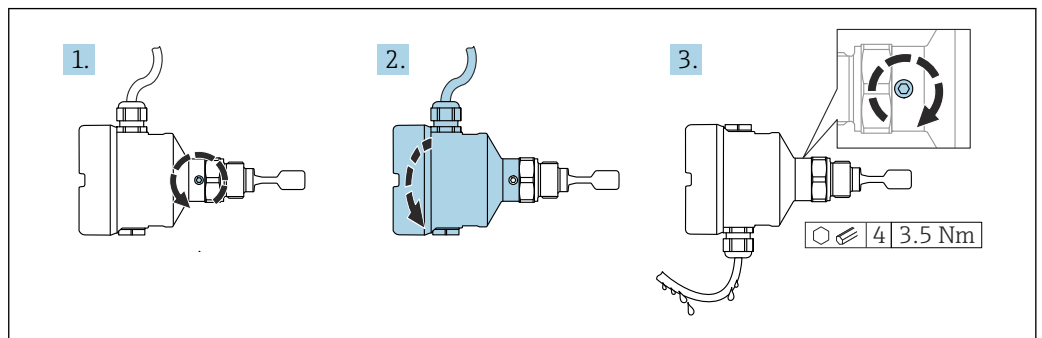

15 Housing with external locking screw and drip loop

- i** Housings with locking screw:
- The housing can be turned and the cable aligned by turning the locking screw.
 - The locking screw is not tightened when the device is delivered.

1. Loosen the external locking screw (maximum 1.5 turns).
2. Turn the housing, align the cable entry.
 - ↳ Avoid moisture in the housing, provide a loop to allow moisture to drain off.
3. Tighten the external locking screw.

NOTICE

The housing cannot be unscrewed fully.

- ▶ Loosen the external locking screw by a maximum of 1.5 turns. If the screw is unscrewed too much or completely (beyond the screw anchor point), small parts (counter disk) can become loose and fall out.
- ▶ Tighten the securing screw (hexagon socket 4 mm (0.16 in)) with maximum 3.5 Nm (2.58 lbf ft) ± 0.3 Nm (± 0.22 lbf ft).

Closing the housing covers

NOTICE

Thread and housing cover damaged from dirt and fouling!

- ▶ Remove dirt (e.g. sand) on the thread of the covers and housing.
- ▶ If you continue to encounter resistance when closing the cover, check the thread again for fouling.

i Housing thread

The threads of the electronics and connection compartment can be coated with an anti-friction coating.

The following applies for all housing materials:

- ✗ **Do not lubricate the housing threads.**

5.3 Sliding sleeves

 For more details, see the "Accessories" section.

5.4 Post-mounting check

- Is the device undamaged (visual inspection)?
- Does the measuring device meet the measuring point specifications?

For example:

- Process temperature
 - Process pressure
 - Ambient temperature
 - Measuring range
- Are the measuring point number and labeling correct (visual inspection)?
 - Is the device adequately protected from wet conditions and direct sunlight?
 - Is the device properly secured?

6 Electrical connection

6.1 Required tool

- Screwdriver for electrical connection
- Allen key for screw of cover lock

6.2 Connecting requirements

6.2.1 Cover with securing screw

The cover is locked by a securing screw in devices for use in hazardous areas with certain explosion protection.

NOTICE

If the securing screw is not positioned correctly, the cover cannot provide secure sealing.

- ▶ Open the cover: slacken the screw of the cover lock with a maximum of 2 turns so that the screw does not fall out. Fit the cover and check the cover seal.
- ▶ Close the cover: screw the cover securely onto the housing, making sure that the securing screw is positioned correctly. There should not be any gap between the cover and housing.

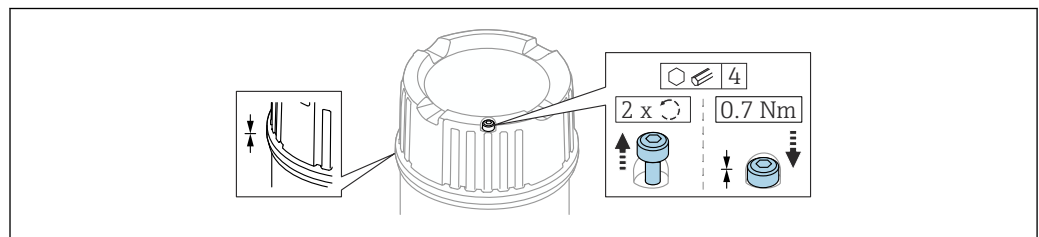

A0039520

 16 Cover with securing screw

6.2.2 Connecting protective earth (PE)

When the device is used in hazardous areas, it must always be included in the potential equalization of the system, irrespective of the operating voltage. This is possible by connecting to the inner or outer protective ground connection (PE).

6.3 Connecting the device

i Housing thread

The threads of the electronics and connection compartment can be coated with an anti-friction coating.

The following applies for all housing materials:

✗ Do not lubricate the housing threads.

6.3.1 2-wire density (electronic insert FEL60D) for density measurement

NOTICE

Operation with other switching units is not permitted.

Destruction of electronic components.

- ▶ Do not install the FEL60D electronic insert in devices that were originally used as point level switches.

Terminal assignment

The output signal of the density sensor is based on pulse technology. With the aid of this signal, the fork frequency is constantly forwarded to the Density Computer FML621.

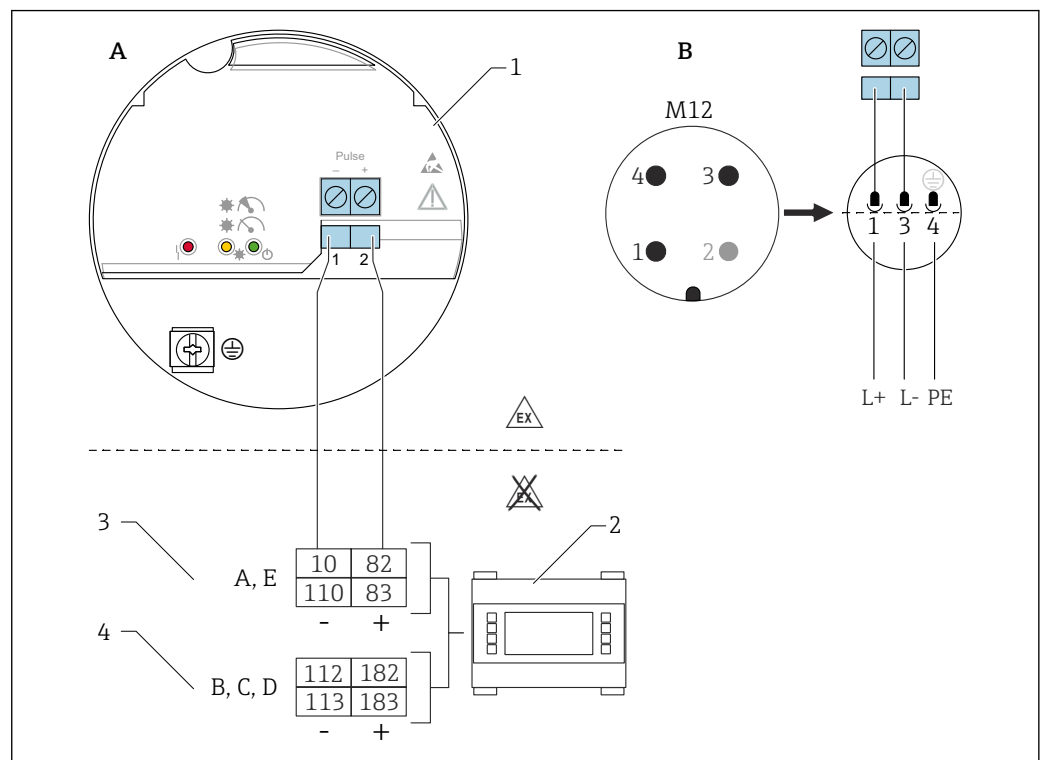

17 Connection diagram: electronic insert FEL60D connection to Density Computer FML621

- A Connection wiring with terminals
- B Connection wiring with M12 plug in housing as per EN61131-2 standard
- 1 Electronic insert FEL60D
- 2 Density Computer FML621
- 3 Slots A, E with extension cards (already installed in the basic unit)
- 4 Slots B, C, D with extension cards (optional)

Supply voltage

$U = 24 V_{DC} \pm 15 \%$, only suitable for connecting to the Density Computer FML621



The device must be powered by a voltage supply categorized as "CLASS 2" or "SELV".

Power consumption

$P < 160 \text{ mW}$

Current consumption

$I < 10 \text{ mA}$

Overvoltage protection

Overvoltage category I

Adjustment

There are 3 different types of adjustment:

- Standard adjustment (order configuration):
Two fork parameters are determined at the factory to describe the sensor characteristics and are provided in the calibration report with the product. These parameters must be transmitted to the Density Computer FML621.
- Special adjustment (select in the Product Configurator):
Three fork parameters are determined at the factory to describe the sensor characteristics and are provided in the calibration report with the product. These parameters must be transmitted to the Density Computer FML621.
This type of adjustment achieves an even higher level of accuracy.
- Field adjustment:
With a field adjustment, the density determined by the user is transmitted to the FML621.



All the necessary parameters of the Liquiphant Density are documented in the **adjustment report** and in the **sensor pass**.

The documents are included in the scope of delivery.



Further information and the documentation currently available can be found on the Endress+Hauser website: www.endress.com → Downloads.

Density measurement

The Liquiphant Density measures the density of a liquid medium in pipes and tanks. The device is suitable for all Newtonian (purely viscous) fluids. In addition, the device is also suitable for use in hazardous areas.

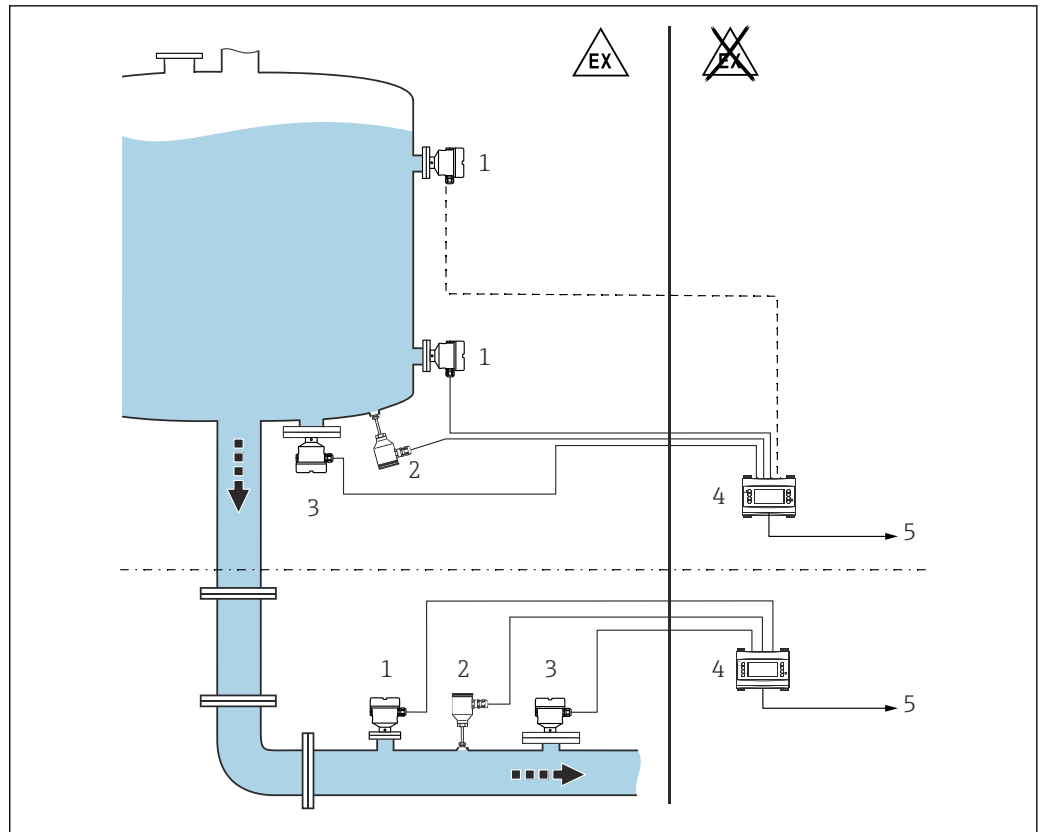

A0039632

18 Density measurement with Density Computer FML621

- 1 Liquiphant Density → Pulse output
- 2 Temperature sensor, e.g. 4 to 20 mA output
- 3 Pressure transmitter 4 to 20 mA output required for changes in pressure >6 bar
- 4 Liquiphant Density Computer FML621 with display and operating unit
- 5 PLC



The measurement can be affected by:

- air bubbles at the sensor
- unit not fully covered by the medium
- solid media buildup on the sensor
- high flow velocity in pipes
- severe turbulence in the pipe due to inlet and outlet runs that are too short
- corrosion of the fork
- non-Newtonian (not purely viscous) behavior of media

6.3.2 Connecting the cables

Required tools

- Flat-blade screwdriver (0.6 mm x 3.5 mm) for terminals
- Suitable tool with width across flats AF24/25 (8 Nm (5.9 lbf ft)) for M20 cable gland

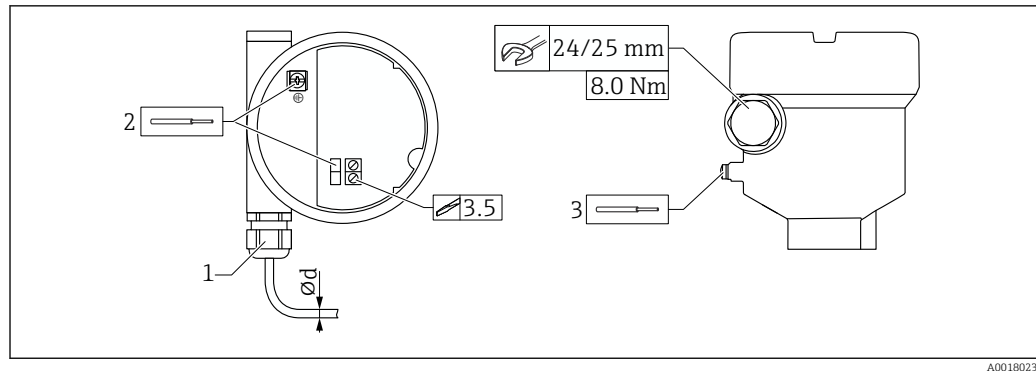

19 Example of coupling with cable entry, electronic insert with terminals

- 1 M20 coupling (with cable entry), example
 - 2 Conductor cross-section maximum 2.5 mm^2 (AWG14), ground terminal on inside in housing + terminals on the electronics
 - 3 Conductor cross-section maximum 4.0 mm^2 (AWG12), ground terminal on outside of the housing (example: plastic housing with outer protective ground connection (PE))
- Ød Nickel-plated brass 7 to 10.5 mm (0.28 to 0.41 in),
Plastic 5 to 10 mm (0.2 to 0.38 in),
Stainless steel 7 to 12 mm (0.28 to 0.47 in)

i Pay attention to the following when using the M20 coupling

Following cable entry:

- Counter-tighten the coupling
- Tighten the union nut of the coupling with 8 Nm (5.9 lbf ft)
- Screw the enclosed coupling into the housing with 3.75 Nm (2.76 lbf ft)

6.3.3 Post-connection check

- Is the device or cable undamaged (visual inspection)?
- Do the cables used comply with the requirements?
- Do the mounted cables have adequate strain relief?
- Are the cable glands mounted and firmly tightened?
- Does the supply voltage match the information on the nameplate?
- No reverse polarity, is terminal assignment correct?
- If supply voltage is present, is the green LED lit?
- Are all the housing covers installed and tightened?
- Optional: Is the cover tightened with securing screw?

7 Operation options

7.1 Overview of operation options

7.1.1 Operating concept

Operation with the Density Computer FML621. For details, see documentation for the Density Computer FML621.

7.1.2 Elements on the electronic insert

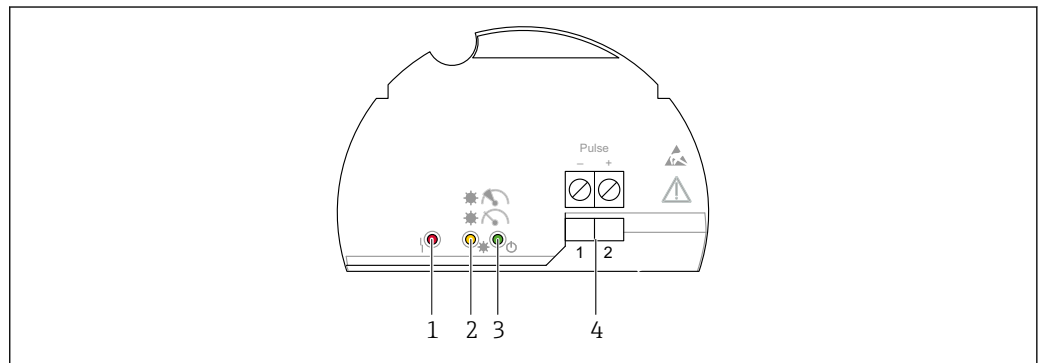



 20 Electronic insert FEL60D

- 1 LED red, for warning or alarm
- 2 LED yellow, stability of measurement
- 3 LED green, operational status (device is on)
- 4 Pulse output terminals

8 Commissioning

8.1 Function check

Before commissioning the measuring point, check whether the post-installation and post-connection checks have been performed.

-  ▪ →  Post-installation check
- →  Post-connection check

8.2 Switching on the device

- ▶ Switch on
 - ↳ The green LED is lit and the yellow LED flashes 2-3 times



The measurement is stable if both LEDs (green and yellow) are then lit.

9 Operation

9.1 Light signals

Yellow LED

Symbols, information

 /  Stable measurement

 /  Unstable measurement/process conditions

 Maintenance required

Green LED

Symbols, information

 /  Power on

 /  Power off

Red LED

Symbols, information

 /  No fault

 Maintenance required

 Device failure



For more information, see the Technical Information for Liquiphant Density.

10 Diagnostics and troubleshooting

The device indicates warnings and errors via the LEDs on the electronic insert. The errors diagnosed by the device are displayed in accordance with NE107. Depending on the diagnostic message, the device behaves as per a warning or fault condition.

The device behaves in accordance with NAMUR Recommendation NE131 "NAMUR standard device requirements for field devices for standard applications".

10.1 Diagnostic information via light emitting diodes

10.1.1 LED at electronic insert

  **indicator: power supply or off**



- No supply voltage present: check supply voltage
- Reverse polarity: check terminal assignment
- Signal line is defective: check signal line
- Incorrect terminal assignment at FML: check terminal configuration at FML621

  **indicator: unstable process conditions**

- Extreme vibrations from an external source: isolate measuring point from vibrations
- Extremely turbulent flow: provide a calming section
- Flow rate > 2 m/s: keep tuning fork away from direct flow of medium
- Buildup: remove buildup, allow for cleaning intervals

  **indicator: maintenance required**

- Extreme vibrations from an external source: isolate measuring point from vibrations
- Flow rate > 2 m/s: keep tuning fork away from direct flow of medium
- Buildup: remove buildup, allow for cleaning intervals
- Tuning fork is blocked: change installation position

  **indicator: device failure**

- Electronic insert is defective: replace electronic insert
- No connection to sensor: replace sensor

10.2 Firmware history

V01.00.zz (06.2019)

- Valid for electronic insert: FEL60D
- Valid from documentation version: BA01974F/00/EN/01.19 (Liquiphant FTL51B Density)
- Changes: none; 1st version (original software)

11 Maintenance

No special maintenance work is required.

11.1 Maintenance tasks

11.1.1 Cleaning

It is not permitted to use the device with abrasive media. Material abrasion on the tuning fork can result in the device malfunctioning.

- Clean the tuning fork as necessary
- Cleaning is also possible in the installed state, e. g. CIP Cleaning in Place and SIP Sterilization in Place

12 Repair

12.1 General notes

12.1.1 Repair concept

Endress+Hauser repair concept

- The devices have a modular design
- Customers can carry out repairs

 For more information on service and spare parts, please contact your Endress+Hauser sales representative.

12.1.2 Repairs to Ex-approved devices

WARNING

Incorrect repair can compromise electrical safety!

Explosion hazard!

- ▶ Only specialist personnel or the manufacturer's service team may carry out repairs on Ex-certified devices in accordance with national regulations.
- ▶ Relevant standards and national regulations on hazardous areas, safety instructions and certificates must be observed.
- ▶ Only use original spare parts from the manufacturer.
- ▶ Please note the device designation on the nameplate. Only identical parts may be used as replacements.
- ▶ Carry out repairs according to the instructions.
- ▶ Only the manufacturer's service team is permitted to modify a certified device and convert it to another certified version.

12.2 Spare parts

- Some replaceable device components are identified by a spare part nameplate. This contains information about the spare part.
- All the spare parts for the measuring device, along with the order code, are listed in the *W@M Device Viewer* (www.endress.com/deviceviewer) and can be ordered. If available, users can also download the associated Installation Instructions.

 Device serial number or QR code:
Located on the device and spare part nameplate.

12.3 Return

The requirements for safe device return can vary depending on the device type and national legislation.

1. Refer to the web page for information:
<http://www.endress.com/support/return-material>
↳ Select the region.
2. Return the device if repairs or a factory calibration are required, or if the wrong device was ordered or delivered.

12.4 Disposal



If required by the Directive 2012/19/EU on waste electrical and electronic equipment (WEEE), the product is marked with the depicted symbol in order to minimize the disposal of WEEE as unsorted municipal waste. Do not dispose of products bearing this marking as unsorted municipal waste. Instead, return them to the manufacturer for disposal under the applicable conditions.

13 Accessories for Liquiphant Density

13.1 Protective cover for aluminum dual compartment housing

- Material: stainless steel 316L
- Order number: 71438303

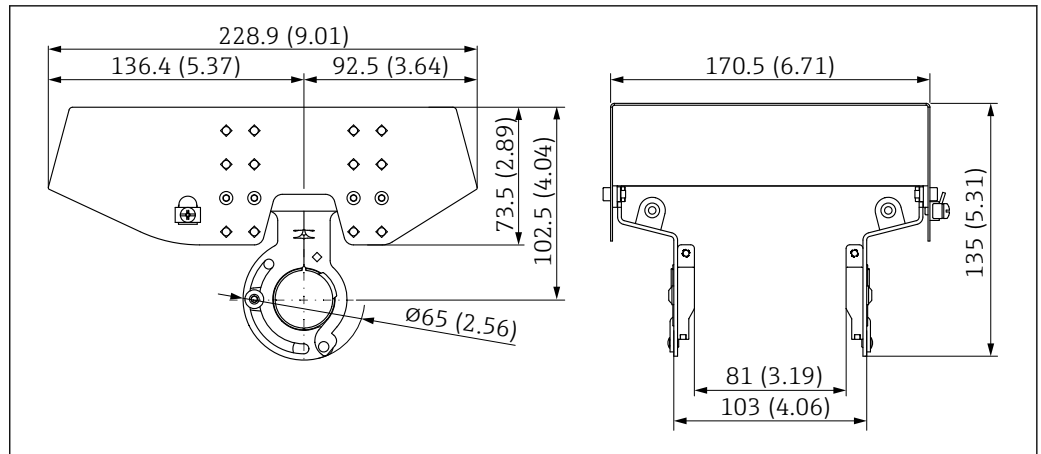

A0039231

21 Protective cover for aluminum dual compartment housing. Unit of measurement mm (in)

13.2 Protective cover for single compartment housing, aluminum or 316L

- Material: plastic
- Order number: 71438291

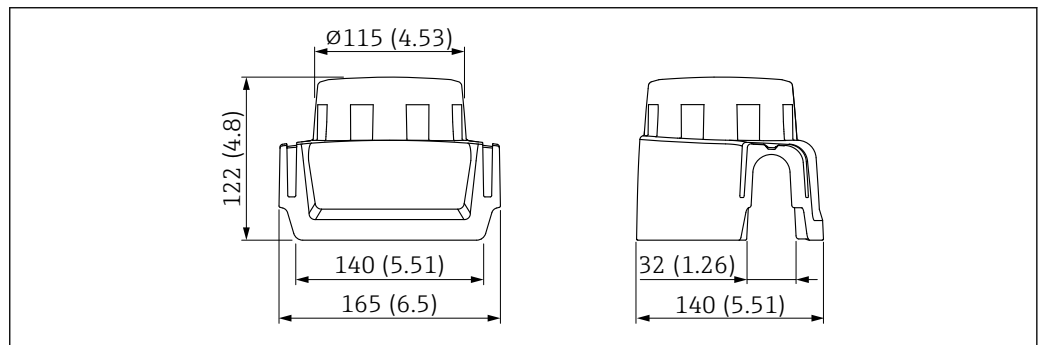

A0038280

22 Protective cover for single compartment housing, aluminum or 316L. Unit of measurement mm (in)

13.3 M12 socket

i The M12 sockets listed are suitable for use in the temperature range -25 to $+70$ °C (-13 to $+158$ °F).

M12 socket IP69

- Terminated at one end
- Angled
- 5 m (16 ft) PVC cable (orange)
- Slotted nut 316L (1.4435)
- Body: PVC
- Order number: 52024216

M12 socket IP67

- Angled
- 5 m (16 ft) PVC cable (gray)
- Slotted nut Cu Sn/Ni
- Body: PUR
- Order number: 52010285

13.4 Weld-in adapter

Various weld-in adapters are available for installation in vessels or pipes. The adapters are optionally available with inspection certificate 3.1 EN10204.

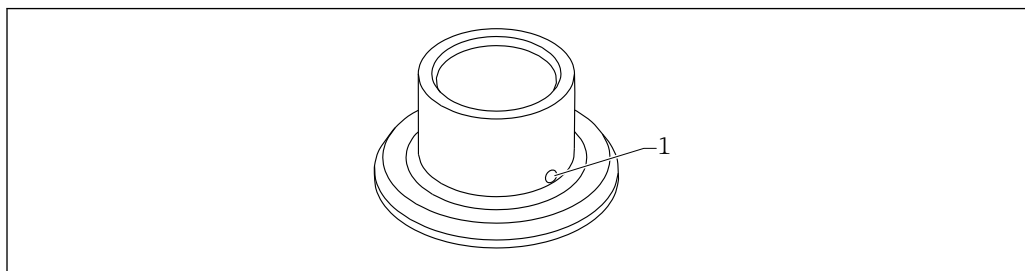

A0023557

 23 *Weld-in adapter (sample view)*

1 *Leakage hole*

Weld-in adapter G 1:

FDA-listed materials as per 21 CFR Part 175-178

- Ø 53 mounting on the pipe
- Ø60 flush mount on the vessel

Weld-in adapter G ¾:

FDA-listed materials as per 21 CFR Part 175-178

Ø55 flush mount

Weld in the weld-in adapter in such a way that the leakage hole is pointing downwards. This enables any leaks to be detected quickly.

 For detailed information, see "Technical Information" TI00426F (Weld-in adapters, process adapters and flanges)

Available in the Downloads area of the Endress+Hauser website (www.endress.com/downloads).

14 Accessories for Density Computer FML621

14.1 General

R XU10-A1

Cable set for Density Computer FML621 for connecting to a PC or modem

F ML621A-AA

Remote display for panel mounting:

- B: 144 mm (5.67 in)
- H: 72 mm (2.83 in)
- T: 43 mm (1.69 in)

R MS621A-P1

PROFIBUS interface

51004148

Adhesive label, printed, max. 2 x 16 characters

51002393

Metal sign for TAG number

51010487

Sign, paper, TAG 3 x 16 characters

14.2 Extension cards

The device can be extended with a maximum of three universal or digital or current or Pt100 cards.

FML621A-DA

Digital

- 6 x digital input
- 6 x relay output
- Kit with terminals and fixing frame

FML621A-DB

Digital, ATEX-approved

- 6 x digital input
- 6 x relay output
- Kit with terminals

FML621A-CA

2x U, I, TC

- 2x 0 to 20 mA or 4 to 20 mA per pulse
- 2x digital
- 2x SPST relay

FML621A-CB

Multifunction, 2x U, I, TC ATEX

- 2x 0 to 20 mA or 4 to 20 mA per pulse
- 2x digital
- 2x SPST relay

FML621A-TA

Temperature (Pt100/Pt500/Pt1000)

Complete, including terminals and securing frame

FML621A-TB

Temperature, ATEX-approved (Pt100/PT500/PT1000)

Complete, including terminals

FML621A-UA

Universal - PFM or pulse or analog or transmitter power supply

Complete, including terminals and securing frame

FML621A-UB

Universal ATEX-approved - PFM or pulse or analog or transmitter power supply

Complete, including terminals

14.3 PROFINET® Interface

Order code RMS621A-P2

15 Technical data

15.1 Input

15.1.1 Measured variable

Density of liquids

15.1.2 Measuring range

Density range: 0.3 to 2 g/cm³

15.2 Output

15.2.1 Output and input variants

2-wire density (FEL60D) for density measurement

Connection to Density Computer FML621

15.2.2 Ex connection data

See safety instructions (XA): All data relating to explosion protection are provided in separate Ex documentation and are available from the Downloads area of the Endress+Hauser website. The Ex documentation is supplied as standard with all devices approved for use in explosion hazardous areas.

15.3 Environment

15.3.1 Ambient temperature range

-40 to 70 °C (-40 to 158 °F)

The minimum permitted ambient temperature of the plastic housing is limited to -20 °C (-4 °F); 'indoor use' applies for North America.

Outdoor operation in strong sunlight:

- Mount the device in a shaded location
- Avoid direct sunlight, particularly in warmer climatic regions
- Use a weather protection cover, can be ordered as an accessory

 Further information on using the device in hazardous areas (ATEX) and on documentation that is currently available can be found on the Endress+Hauser website: www.endress.com → Downloads.

15.3.2 Storage temperature

-40 to +80 °C (-40 to +176 °F)

15.3.3 Operating altitude

As per IEC 61010-1 Ed.3:

- Up to 2 000 m (6 600 ft) above sea level
- Can be extended to 3 000 m (9 800 ft) above sea level if overvoltage protection is used

15.3.4 Climate class

As per IEC 60068-2-38 test Z/AD

15.3.5 Degree of protection

Testing according to IEC 60529 and NEMA 250

IP68 test condition: 1.83 m H₂O for 24 h

Housing

See cable entries

Cable entries

- M20 coupling, plastic, IP66/68 NEMA Type 4X/6P
- M20 coupling, nickel-plated brass, IP66/68 NEMA Type 4X/6P
- M20 coupling, 316L, IP66/68 NEMA Type 4X/6P
- M20 coupling, 316L, hygienic, IP66/68/69 NEMA Type 4X/6P
- M20 thread, IP66/68 NEMA Type 4X/6P
- G ½ thread, NPT ½, NPT ¾ IP66/68 NEMA Type 4X/6P

Degree of protection for M12 plug

- When housing is closed and connecting cable is plugged in: IP66/67 NEMA Type 4X
- When housing is open or connecting cable is not plugged in: IP20, NEMA Type 1

NOTICE**M12 plug: Loss of IP protection class due to incorrect installation!**

- ▶ The degree of protection only applies if the connecting cable used is plugged in and screwed tight.
- ▶ The degree of protection only applies if the connecting cable used is specified according to IP67 NEMA Type 4X.

 If the "M12 plug" option is selected as the electrical connection, **IP66/67 NEMA Type 4X** applies for all housing types.

15.3.6 Pollution degree

Pollution degree 2

15.4 Process**15.4.1 Process temperature range**

0 to 80 °C (32 to 176 °F)

15.4.2 Thermal shock

≤ 120 K/s

15.4.3 Process pressure range

-1 to +25 bar (-14.5 to +362.5 psi)

⚠ WARNING

The maximum pressure for the device depends on the lowest-rated element, with regard to pressure, of the selected component. This means that it is necessary to pay attention to the process connection as well as the sensor.

- ▶ Pressure specifications, see the associated Technical Information.
- ▶ Only operate the device within the specified limits!
- ▶ The Pressure Equipment Directive (2014/68/EU) uses the abbreviation "PS". The abbreviation "PS" corresponds to the MWP (maximum working pressure) of the device.

 Canadian CRN approval: more details about the maximum pressure values are available in the download area of the product page under: www.endress.com → Downloads.

15.4.4 Pressure tightness

Up to vacuum

15.5 Additional technical data



Current Technical Information: Endress+Hauser website: www.endress.com → Downloads.

Index

A

- About this document
- Symbols - description 5

C

- CE mark (Declaration of Conformity) 8

D

- Declaration of Conformity 8
- Disposal 28
- Document
- Purpose 5

E

- Electrical connection
- Terminal assignment 20

I

- Identifying the device 10
- Incoming acceptance 9
- Inspection 9

M

- Mounting
- Mounting requirements 11

N

- Nameplate 10

O

- Operational safety 7

P

- Post-connection check 24
- Product description
- Product design 8
- Product safety 8
- Purpose of this document 5

R

- Repair concept 27
- Requirements for the personnel 6
- Return 28

S

- Securing screw 20
- Spare parts 28
- Nameplate 28

T

- Technical data
- Measured variables
- Measuring ranges 31
- Process range 33
- Transport
- Handling 10

W

- W@M Device Viewer 10, 28
- Workplace safety 7



www.addresses.endress.com
