

Special Documentation

Hygienic process connection types

Supplement to TM311, TM371, TM372, TM401,
TM411, TM402, TM412, TT411, TT412, TE411, TK40,
TMR35, DTT35, TTR35



Table of contents

- 1 Introduction 4
- 2 Installation instructions 5
- 3 Process connections 6

1 Introduction

Endress+Hauser thermometers for hygienic and aseptic applications are available with different process connection types. If a standard thermometer cannot be ordered with the required standard process connection via the product configurator, this special combination must be manufactured on customer's request.

For this reason, this document is available as a supplementary documentation so that the technical data for all available process connections can be called up via serial number:

- Internet: www.endress.com/deviceviewer
- Smartphone/tablet: Endress+Hauser Operations App

in addition to the associated Technical Information (TI), the Operating Instructions (BA) or the Brief Operating Instructions (KA).

Supplementary documentation for:

Thermometer	Documentation type
TM311	TI01439T BA01952T KA01437T
TM371	TI01292T BA01581T KA01272T
TM372	TI01612T BA02224T KA01563T
TMR35	TI00123R BA00215R
TTR35	TI00105R BA00229R
DTT35	TI00125R BA00235R
TM401	TI01058T BA02023T
TM411 (TE411, TK40)	TI01038T BA02023T
TT411	TI01099T BA02023T
TM402	TI01349T BA02023T
TM412	TI01348T BA02023T
TT412	TI01350T BA02023T

NOTICE

Maximum pressure and temperature may be limited by the thermometer or thermowell type. Maximum design pressure and temperature stated is for the process connection only and not for the thermometer type.

- ▶ Check the technical specifications in the related Technical Information and Operating Instructions (BA or KA) for thermometer pressure-temperature ratings.

2 Installation instructions

The immersion length of the thermometer can influence the accuracy. If the immersion length is too small then errors in the measurement are caused by heat conduction via the process connection and the container wall. If installing in a pipe, the immersion length should ideally correspond to half of the pipe diameter.

- Installation possibilities: pipes, tanks or other plant components
- To minimize the heat conduction error, a minimum immersion length is recommended depending on the type of sensor used and the design of the insert. This immersion length corresponds to the minimum insertion length for the calibration.

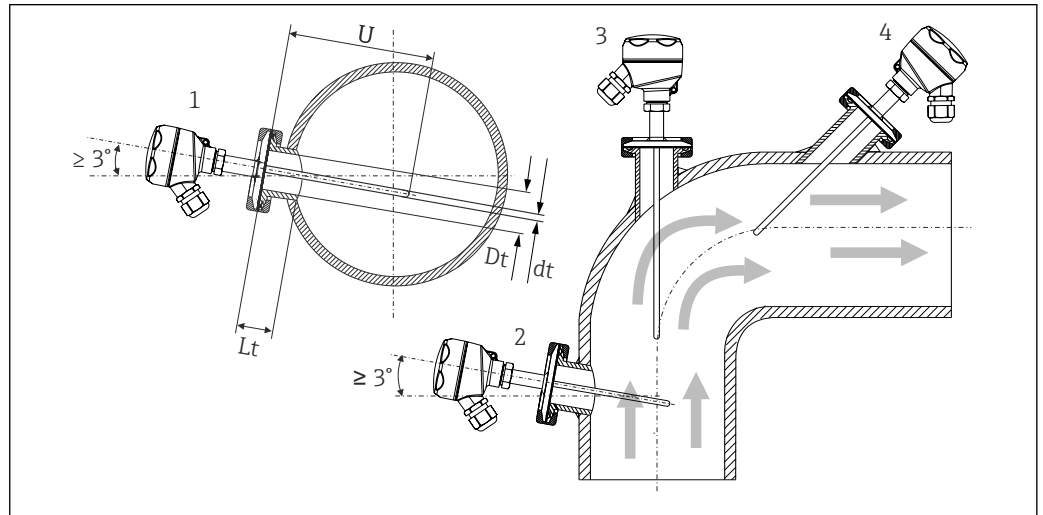

1 Installation examples

- 1, 2 Perpendicular to the flow direction, installed at a min. angle of 3° to ensure self-draining
 3 On elbows
 4 Inclined installation in pipes with a small nominal diameter
 U Immersion length

i In the case of pipes with a small nominal diameter, it is advisable for the tip of the thermometer to project well into the process so that it extends past the pipe axis. Installation at an angle (4) could be another solution. When determining the immersion length or installation depth, all the parameters of the thermometer and of the medium to be measured must be taken into account (e.g. flow velocity, process pressure).

i The requirements of the EHEDG and the 3-A Sanitary Standard must be adhered to.
 Installation instructions EHEDG/cleanability: $L_t \leq (D_t - d_t)$
 Installation instructions 3-A/cleanability: $L_t \leq 2(D_t - d_t)$

1. As a general rule, the thermometers should be installed in such a way that does not impact their ability to be cleaned (the requirements of the 3-A Sanitary Standard must be observed).
2. The Varivent® and Liquiphant-M weld-in adapter and Ingold (+ weld-in adapter) connections enable flush-mounted installation.

3 Process connections

All dimensions in mm (in).

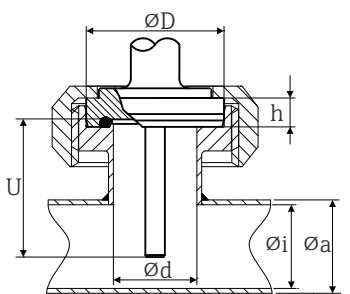
Type	Row A	Dimensions					Technical properties
		ϕd	ϕD	ϕi	ϕa	h	
Aseptic pipe union according to DIN 11864-1, Form A 	DN25	26 mm (1.02 in)	42.9 mm (1.7 in)	26 mm (1.02 in)	29 mm (1.14 in)	9 mm (0.35 in)	<ul style="list-style-type: none"> ■ P_{max.} = 40 bar (580 psi) ■ Pressure temperature = -10 to +140 °C (14 to 284 °F) ■ 3-A marked and EHEDG certified ■ ASME BPE compliance
	DN32	32 mm (1.38 in)	48.9 mm (1.9 in)	32 mm (1.38 in)	35 mm (1.4 in)	10 mm (0.39 in)	
	DN40	38 mm (1.5 in)	54.9 mm (2.16 in)	38 mm (1.5 in)	41 mm (1.61 in)	10 mm (0.39 in)	
	DN50	50 mm (1.97 in)	66.9 mm (2.63 in)	50 mm (1.97 in)	53 mm (2.09 in)	11 mm (0.43 in)	

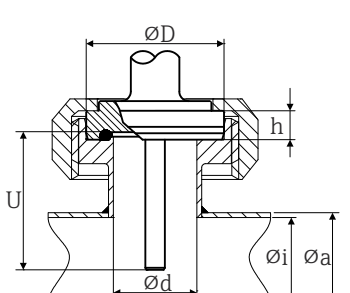
Type	Row B	Dimensions					Technical properties
		ϕd	ϕD	ϕi	ϕa	h	
Aseptic pipe union according to DIN 11864-1, Form A 	DN26.9	23.7 mm (0.93 in)	42.9 mm (1.7 in)	23.7 mm (0.93 in)	26.9 mm (1.06 in)	9 mm (0.35 in)	<ul style="list-style-type: none"> ■ P_{max.} = 40 bar (580 psi) ■ Pressure temperature = -10 to +140 °C (14 to 284 °F) ■ 3-A marked and EHEDG certified ■ ASME BPE compliance
	DN33.7	29.7 mm (1.17 in)	48.9 mm (1.93 in)	29.7 mm (1.17 in)	33.7 mm (1.33 in)	10 mm (0.39 in)	
	DN42.4	38.4 mm (1.5 in)	54.9 mm (2.16 in)	38.4 mm (1.5 in)	42.4 mm (1.67 in)	10 mm (0.39 in)	
	DN48.3	44.3 mm (1.74 in)	66.9 mm (2.63 in)	44.3 mm (1.74 in)	48.3 mm (1.9 in)	11 mm (0.43 in)	
	DN60.3	56.3 mm (2.22 in)	84.9 mm (3.34 in)	56.3 mm (2.22 in)	60.3 mm (2.37 in)	12 mm (0.74 in)	
	DN76.1	72.1 mm (2.84 in)	98.9 mm (3.89 in)	72.1 mm (2.84 in)	76.1 mm (2.99 in)	12 mm (0.74 in)	
	DN88.9	84.3 mm (3.32 in)	118.9 mm (4.68 in)	84.3 mm (3.32 in)	88.9 mm (3.5 in)	15 mm (0.59 in)	

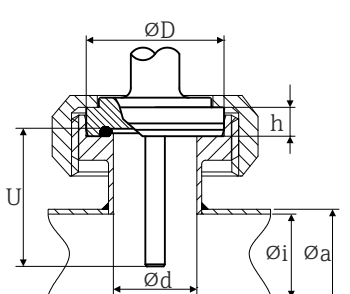
Type	Row C	Dimensions					Technical properties
		ϕd	ϕD	ϕi	ϕa	h	
Aseptic pipe union according to DIN 11864-1, Form A 	DN 1" ¹⁾	22.1 mm (0.87 in)	42.9 mm (1.7 in)	22.1 mm (0.87 in)	25.4 mm (1 in)	9 mm (0.35 in)	<ul style="list-style-type: none"> ■ P_{max.} = 40 bar (580 psi) ■ Pressure temperature = -10 to +140 °C (14 to 284 °F) ■ 3-A marked and EHEDG certified ■ ASME BPE compliance
	DN 1½"	34.8 mm (1.37 in)	54.9 mm (2.16 in)	34.8 mm (1.37 in)	38.1 mm (1.5 in)	10 mm (0.39 in)	

Type	Row C	Dimensions					Technical properties
		ϕd	ϕD	ϕi	ϕa	h	
	DN 2"	47.5 mm (1.87 in)	66.9 mm (2.63 in)	47.5 mm (1.87 in)	50.8 mm (2 in)	11 mm (0.43 in)	<ul style="list-style-type: none"> ■ $P_{max.} = 25 \text{ bar (362.6 psi)}$ ■ Pressure temperature = -10 to +140 °C (14 to 284 °F) ■ 3-A marked and EHEDG certified ■ ASME BPE compliance
	DN 2½"	60.2 mm (2.37 in)	84.9 mm (3.34 in)	60.2 mm (2.37 in)	63.5 mm (2.5 in)	12 mm (0.74 in)	

1) EHEDG for dt = 6 mm (0.24 in) only

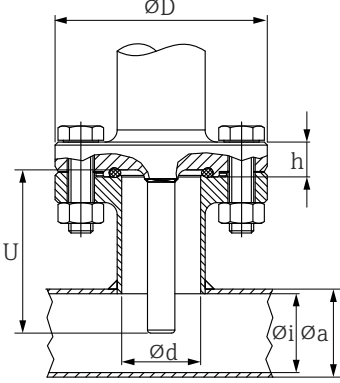
Type	Row A	Dimensions					Technical properties
		ϕd	ϕD	ϕi	ϕa	h	
Aseptic pipe union according to DIN 11864-2, Form A 	DN25	26 mm (1.02 in)	70 mm (2.76 in)	26 mm (1.02 in)	29 mm (1.14 in)	11.5 mm (0.45 in)	<ul style="list-style-type: none"> ■ $P_{max.} = 40 \text{ bar (580 psi)}$ ■ Pressure temperature = -10 to +140 °C (14 to 284 °F) ■ 3-A marked and EHEDG certified ■ ASME BPE compliance
	DN32	32 mm (1.38 in)	76 mm (2.97 in)	32 mm (1.38 in)	35 mm (1.4 in)	11.5 mm (0.45 in)	
	DN40	38 mm (1.5 in)	82 mm (3.23 in)	38 mm (1.5 in)	41 mm (1.6 in)	11.5 mm (0.45 in)	
	DN50	50 mm (1.97 in)	94 mm (3.7 in)	50 mm (1.97 in)	53 mm (2.09 in)	11.5 mm (0.45 in)	

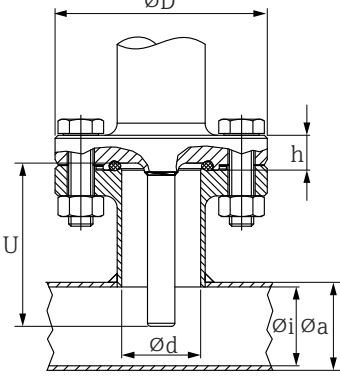
Type	Row B	Dimensions					Technical properties
		ϕd	ϕD	ϕi	ϕa	h	
Aseptic pipe union according to DIN 11864-2, Form A 	DN26.9	23.7 mm (0.93 in)	69 mm (2.72 in)	23.7 mm (0.93 in)	26.9 mm (1.06 in)	11.5 mm (0.45 in)	<ul style="list-style-type: none"> ■ $P_{max.} = 40 \text{ bar (580 psi)}$ ■ Pressure temperature = -10 to +140 °C (14 to 284 °F) ■ 3-A marked and EHEDG certified ■ ASME BPE compliance
	DN33.7	29.7 mm (1.17 in)	74 mm (2.91 in)	29.7 mm (1.17 in)	33.7 mm (1.33 in)	11.5 mm (0.45 in)	
	DN42.4	38.4 mm (1.5 in)	82 mm (3.23 in)	38.4 mm (1.5 in)	42.4 mm (1.67 in)	11.5 mm (0.45 in)	
	DN48.3	44.3 mm (1.74 in)	88 mm (3.64 in)	44.3 mm (1.74 in)	48.3 mm (1.9 in)	11.5 mm (0.45 in)	
	DN60.3	56.3 mm (2.22 in)	103 mm (4.06 in)	56.3 mm (2.22 in)	60.3 mm (2.37 in)	11.5 mm (0.45 in)	
	DN76.1	72.1 mm (2.84 in)	125 mm (4.92 in)	72.1 mm (2.84 in)	76.1 mm (2.99 in)	13.5 mm (0.53 in)	
	DN88.9	84.3 mm (3.32 in)	137 mm (5.4 in)	84.3 mm (3.32 in)	88.9 mm (3.5 in)	13.5 mm (0.53 in)	

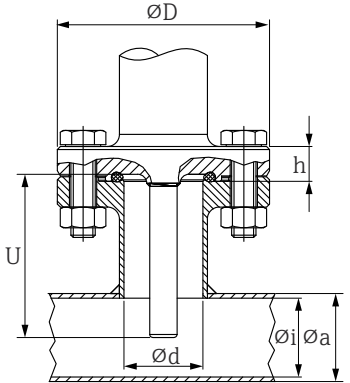
Type	Row C	Dimensions					Technical properties
		ϕd	ϕD	ϕi	ϕa	h	
Aseptic pipe union according to DIN 11864-2, Form A 	DN 1" ¹⁾	22.1 mm (0.87 in)	66 mm (2.6 in)	22.1 mm (0.87 in)	25.4 mm (1 in)	11.5 mm (0.45 in)	<ul style="list-style-type: none"> ■ $P_{max.} = 40$ bar (580 psi) ■ Pressure temperature = -10 to +140 °C (14 to 284 °F) ■ 3-A marked and EHEDG certified ■ ASME BPE compliance
	DN 1½"	34.8 mm (1.37 in)	79 mm (3.11 in)	34.8 mm (1.37 in)	38.1 mm (1.5 in)	11.5 mm (0.45 in)	
	DN 2"	47.5 mm (1.87 in)	92 mm (3.62 in)	47.5 mm (1.87 in)	50.8 mm (2 in)	11.5 mm (0.45 in)	<ul style="list-style-type: none"> ■ $P_{max.} = 25$ bar (362.6 psi) ■ Pressure temperature = -10 to +140 °C (14 to 284 °F) ■ 3-A marked and EHEDG certified ■ ASME BPE compliance
	DN 2½"	60.2 mm (2.37 in)	107 mm (4.21 in)	60.2 mm (2.37 in)	63.5 mm (2.5 in)	11.5 mm (0.45 in)	

1) EHEDG for dt = 6 mm (0.24 in) only

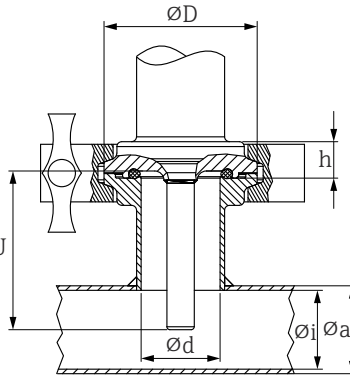
Type	Row A	Dimensions					Technical properties
		ϕd	ϕD	ϕi	ϕa	h	
Aseptic pipe union according to DIN 11864-3, Form A 	DN25	26 mm (1.02 in)	50.5 mm (1.99 in)	26 mm (1.02 in)	29 mm (1.14 in)	13 mm (0.51 in)	<ul style="list-style-type: none"> ■ $P_{max.} = 40$ bar (580 psi) ■ Pressure temperature = -10 to +140 °C (14 to 284 °F) ■ 3-A marked and EHEDG certified ■ ASME BPE compliance
	DN32	32 mm (1.38 in)	50.5 mm (1.99 in)	32 mm (1.38 in)	35 mm (1.4 in)	13 mm (0.51 in)	
	DN40	38 mm (1.5 in)	64 mm (2.52 in)	38 mm (1.5 in)	41 mm (1.6 in)	13 mm (0.51 in)	
	DN50	50 mm (1.97 in)	77.5 mm (3.05 in)	50 mm (1.97 in)	53 mm (2.09 in)	15 mm (0.6 in)	<ul style="list-style-type: none"> ■ $P_{max.} = 25$ bar (362.6 psi) ■ Pressure temperature = -10 to +140 °C (14 to 284 °F) ■ 3-A marked and EHEDG certified ■ ASME BPE compliance

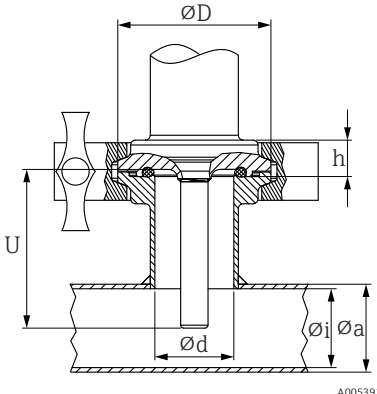
Type	Row B	Dimensions					Technical properties
		ϕd	ϕD	ϕi	ϕa	h	
Aseptic pipe union according to DIN 11864-3, Form A 	DN26.9	23.7 mm (0.93 in)	50.5 mm (1.99 in)	23.7 mm (0.93 in)	26.9 mm (1.06 in)	13 mm (0.51 in)	<ul style="list-style-type: none"> ■ $P_{max.} = 40$ bar (580 psi) ■ Pressure temperature = -10 to +140 °C (14 to 284 °F) ■ 3-A marked and EHEDG certified ■ ASME BPE compliance
	DN33.7	29.7 mm (1.17 in)	50.5 mm (1.99 in)	29.7 mm (1.17 in)	33.7 mm (1.33 in)	13 mm (0.51 in)	
	DN42.4	38.4 mm (1.5 in)	64 mm (2.52 in)	38.4 mm (1.5 in)	42.4 mm (1.67 in)	13 mm (0.51 in)	<ul style="list-style-type: none"> ■ $P_{max.} = 25$ bar (362.6 psi) ■ Pressure temperature = -10 to +140 °C (14 to 284 °F) ■ 3-A marked and EHEDG certified ■ ASME BPE compliance
	DN48.3	44.3 mm (1.74 in)	64 mm (2.52 in)	44.3 mm (1.74 in)	48.3 mm (1.9 in)	13 mm (0.51 in)	
	DN60.3	56.3 mm (2.22 in)	91 mm (3.58 in)	56.3 mm (2.22 in)	60.3 mm (2.37 in)	15 mm (0.6 in)	<ul style="list-style-type: none"> ■ $P_{max.} = 25$ bar (362.6 psi) ■ Pressure temperature = -10 to +140 °C (14 to 284 °F) ■ 3-A marked and EHEDG certified ■ ASME BPE compliance
	DN76.1	72.1 mm (2.84 in)	106 mm (4.17 in)	72.1 mm (2.84 in)	76.1 mm (2.99 in)	15 mm (0.6 in)	
	DN88.9	84.3 mm (3.32 in)	119 mm (4.69 in)	84.3 mm (3.32 in)	88.9 mm (3.5 in)	15 mm (0.6 in)	

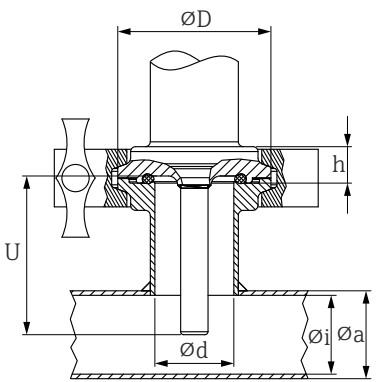
Type	Row C	Dimensions					Technical properties
		ϕd	ϕD	ϕi	ϕa	h	
Aseptic pipe union according to DIN 11864-3, Form A 	DN 1" ¹⁾	22.1 mm (0.87 in)	50.5 mm (1.99 in)	22.1 mm (0.87 in)	25.4 mm (1 in)	13 mm (0.51 in)	<ul style="list-style-type: none"> ■ $P_{max.} = 40$ bar (580 psi) ■ Pressure temperature = -10 to +140 °C (14 to 284 °F) ■ 3-A marked and EHEDG certified ■ ASME BPE compliance
	DN 1½"	34.8 mm (1.37 in)	50.5 mm (1.99 in)	34.8 mm (1.37 in)	38.1 mm (1.5 in)	13 mm (0.51 in)	
	DN 2"	47.5 mm (1.87 in)	64 mm (2.52 in)	47.5 mm (1.87 in)	50.8 mm (2 in)	15 mm (0.6 in)	<ul style="list-style-type: none"> ■ $P_{max.} = 25$ bar (362.6 psi) ■ Pressure temperature = -10 to +140 °C (14 to 284 °F) ■ 3-A marked and EHEDG certified ■ ASME BPE compliance
	DN 2½"	60.2 mm (2.37 in)	77.5 mm (3.05 in)	60.2 mm (2.37 in)	63.5 mm (2.5 in)	15 mm (0.6 in)	





1) EHEDG for $dt = 6$ mm (0.24 in) only

Type TK40 for weld-in	Version	Dimensions			Technical properties ¹⁾
	Spherical or cylindrical	ϕdi	ϕD	h	
	Spherical Material of sealing taper PEEK or 316L Thread G $\frac{1}{4}$ "	6.3 mm (0.25 in) ²⁾	25 mm (0.98 in)	33 mm (1.3 in)	<ul style="list-style-type: none"> ■ P_{max.} = 10 bar (145 psi) ■ T_{max.} for PEEK sealing taper = +150 °C (+302 °F), tightening torque = 10 Nm ■ P_{max.} = 50 bar (725 psi) ■ T_{max.} for 316L sealing taper = +200 °C (+392 °F), tightening torque = 25 Nm ■ The TK40 PEEK sealing taper is EHEDG tested and 3-A marked
	Cylindrical Sealing taper material Elastosil® Thread G $\frac{1}{2}$ "	6.2 mm (0.24 in) ²⁾	30 mm (1.18 in)	57 mm (2.24 in)	

- 1) All the pressure specifications apply for cyclic temperature load
 2) For insert or thermowell diameter $\phi d = 6$ mm (0.236 in).

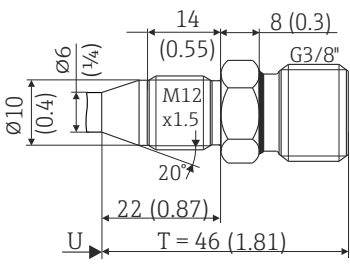
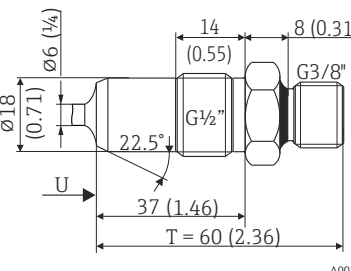
Type	Version	Dimensions	Technical properties
Weld-in adapter 	1: Cylindrical ¹⁾	$\phi d = 12.7$ mm ($\frac{1}{2}$ in), U = immersion length from lower edge of thread, T = 12 mm (0.47 in)	<ul style="list-style-type: none"> ■ P_{max.} depends on the weld-in process ■ 3-A marked and EHEDG certified ■ ASME BPE compliance
	2: Cylindrical ²⁾	$\phi d \times h = 12$ mm (0.47 in) x 40 mm (1.57 in), T = 55 mm (2.17 in)	
	3: Cylindrical	$\phi d \times h = 30$ mm (1.18 in) x 40 mm (1.57 in)	
		$\phi d \times h = 14$ mm (0.55 in) x 40 mm (1.57 in)	
		$\phi d \times h = 30$ mm (1.18 in) x 90 mm (3.54 in)	
4: Spherical-cylindrical	$\phi d = 20$ mm (0.79 in), U = immersion length from lower edge of thread $\phi d \times h = 30$ mm (1.18 in) x 60 mm (2.36 in)		
5: Spherical	$\phi d \times h = 30$ mm (1.18 in) x 40 mm (1.57 in)		
	Cylindrical $\frac{1}{2}$ " NPS	$\phi d = \frac{1}{2}$ " NPS, h = 38.1 mm (1.5 in), U = immersion length from lower edge, T = min. 50.8 mm (2 in)	
	Cylindrical $\frac{3}{4}$ " NPS	$\phi d = \frac{3}{4}$ " NPS, h = 38.1 mm (1.5 in), U = immersion length from lower edge, T = min. 50.8 mm (2 in)	
	Cylindrical 1" NPS	$\phi d = 1$ " NPS, h = 38.1 mm (1.5 in), U = immersion length from lower edge, T = min. 50.8 mm (2 in)	

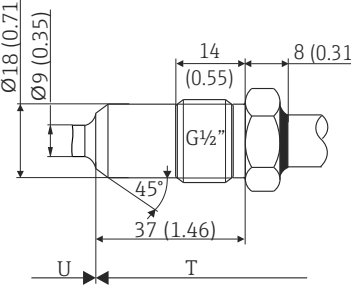
- 1) For protection pipe $\phi 12.7$ mm ($\frac{1}{2}$ in)
 2) For protection pipe $\phi 6$ mm ($\frac{1}{4}$ in)

Type	Version	Technical properties
Metal sealing system		
<p style="text-align: center;">M12x1.5</p> 	<p style="text-align: center;">G½"</p> 	<p>Protection pipe diameter 6 mm (¼ in)</p> <p>$P_{max.} = 16 \text{ bar (232 psi)}$  Maximum torque = 10 Nm (7.38 lbf ft)</p>
-		<p>Protection pipe diameter 9 mm (0.35 in)</p> <p>$P_{max.} = 16 \text{ bar (232 psi)}$  Maximum torque = 10 Nm (7.38 lbf ft)</p>

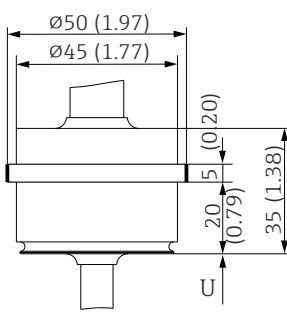
Type	Version	Technical properties
<p style="text-align: center;">Process adapter</p> 	D45	-

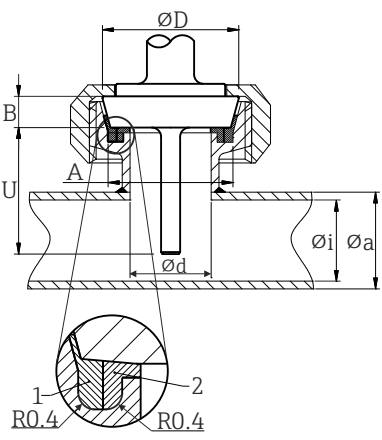
Type		Technical properties				
Sanitary connection according to DIN 11851  <p>1 Centering ring 2 Sealing ring</p>		<ul style="list-style-type: none"> 3-A marked and EHEDG certified (only with EHEDG-certified and self-centering sealing ring). ASME BPE compliance 				
Version ¹⁾	Dimensions					P _{max.}
	øD	A	B	øi	øa	
DN25	44 mm (1.73 in)	30 mm (1.18 in)	10 mm (0.39 in)	26 mm (1.02 in)	29 mm (1.14 in)	40 bar (580 psi)
DN32	50 mm (1.97 in)	36 mm (1.42 in)	10 mm (0.39 in)	32 mm (1.26 in)	35 mm (1.38 in)	40 bar (580 psi)
DN40	56 mm (2.2 in)	42 mm (1.65 in)	10 mm (0.39 in)	38 mm (1.5 in)	41 mm (1.61 in)	40 bar (580 psi)
DN50	68 mm (2.68 in)	54 mm (2.13 in)	11 mm (0.43 in)	50 mm (1.97 in)	53 mm (2.1 in)	25 bar (363 psi)
DN65	86 mm (3.39 in)	80.8 mm (3.18 in)	12 mm (0.47 in)	66 mm (2.6 in)	70 mm (2.76 in)	25 bar (363 psi)

1) Pipes in accordance with DIN 11850

Type	Version	Dimensions		Technical properties	Conformity
	ϕd ¹⁾	ϕD	ϕa		
<p>Clamp according to ISO 2852</p> <p>Form A: In compliance with ASME BPE Type A Form B: In compliance with ASME BPE Type B and ISO 2852</p> <p>A0009566</p>	Microclamp ²⁾ DN8-18 (0.5"-0.75") ³⁾ , Form A	25 mm (0.98 in)	-	<ul style="list-style-type: none"> ■ P_{max.} = 16 bar (232 psi), depends on clamp ring and suitable seal ■ 3-A marked 	-
	Tri-clamp DN8-18 (0.5"-0.75") ³⁾ , Form B		-		
	Clamp DN12-21.3, Form B	34 mm (1.34 in)	16 to 25.3 mm (0.63 to 0.99 in)		ISO 2852
	Clamp DN25-38 (1"-1.5"), Form B	50.5 mm (1.99 in)	29 to 42.4 mm (1.14 to 1.67 in)	<ul style="list-style-type: none"> ■ P_{max.} = 16 bar (232 psi), depends on clamp ring and suitable seal ■ 3-A marked and EHEDG certified (in connection with Combifit seal) ■ Can be used with "Novaseptic Connect (NA Connect)" which enables flush-mount installation 	ASME BPE Type B; ISO 2852
	Clamp DN40-51 (2"), Form B	64 mm (2.52 in)	44.8 to 55.8 mm (1.76 to 2.2 in)		ASME BPE Type B; ISO 2852
	Clamp DN63.5 (2.5"), Form B	77.5 mm (3.05 in)	68.9 to 75.8 mm (2.71 to 2.98 in)		ASME BPE Type B; ISO 2852
	Clamp DN70-76.5 (3"), Form B	91 mm (3.58 in)	> 75.8 mm (2.98 in)		ASME BPE Type B; ISO 2852

- 1) Pipes in accordance with ISO 2037 and BS 4825 Part 1
- 2) Microclamp (not in ISO 2852); no standard pipes
- 3) DN8 (0.5") only possible with protection pipe diameter = 6 mm (¼ in)
- 4) Groove diameter = 20 mm

Type	Version G	Dimensions			Technical properties
		L1 thread length	A	1 (SW/AF)	
<p>Thread according to ISO 228 (for Liquiphant weld-in adapter)</p> <p>A0009572</p>	G¾" for FTL20/31/33 adapter	16 mm (0.63 in)	25.5 mm (1 in)	32	<ul style="list-style-type: none"> ■ P_{max.} = 25 bar (362 psi) at max. 150 °C (302 °F) ■ P_{max.} = 40 bar (580 psi) at max. 100 °C (212 °F) ■ Information about hygienic compliance in connection with FTL31/33/50 adapter see TI00426F
	G¾" for FTL50 adapter				
	G1" for FTL50 adapter	18.6 mm (0.73 in)	29.5 mm (1.16 in)	41	

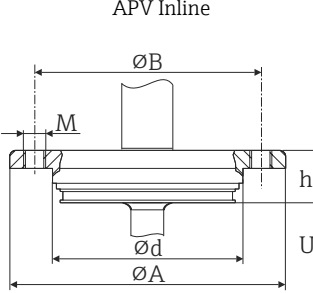
Type	Version	Dimensions					Technical properties
		ϕd	ϕA	ϕB	M	h	
APV Inline 	DN50	69 mm (2.72 in)	99.5 mm (3.92 in)	82 mm (3.23 in)	2xM8	19 mm (0.75 in)	<ul style="list-style-type: none"> ■ P_{max.} = 25 bar (362 psi) ■ 3-A marked and EHEDG certified ■ ASME BPE compliance

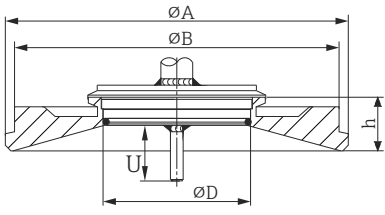
Type	Version	Dimensions				Technical properties	
		ϕD	ϕA	ϕB	h	P _{max.}	
Varivent® 	Type B	31 mm (1.22 in)	105 mm (4.13 in)	-	22 mm (0.87 in)	10 bar (145 psi)	<ul style="list-style-type: none"> ■ 3-A marked and EHEDG certified ■ ASME BPE compliance
	Type F	50 mm (1.97 in)	145 mm (5.71 in)	135 mm (5.31 in)	24 mm (0.95 in)		
	Type N	68 mm (2.67 in)	165 mm (6.5 in)	155 mm (6.1 in)	24.5 mm (0.96 in)		
i The VARINLINE® housing connection flange is suitable for welding into the conical or torispherical head in tanks or containers with a small diameter (≤ 1.6 m (5.25 ft)) and up to a wall thickness of 8 mm (0.31 in).							

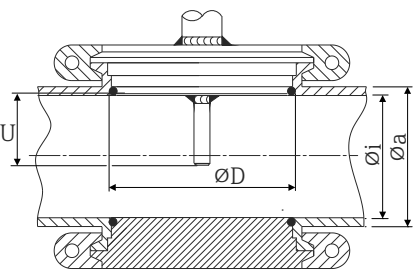
Type	Technical properties
Varivent® for VARINLINE® housing for installation in pipes 	<ul style="list-style-type: none"> ■ 3-A marked and EHEDG certified ■ ASME BPE compliance

Version	Dimensions			P _{max.}
	ϕD	ϕi	ϕa	
Type N, according to DIN 11866, series A	68 mm (2.67 in)	DN40: 38 mm (1.5 in)	DN40: 41 mm (1.61 in)	DN40 to DN65: 16 bar (232 psi)
		DN50: 50 mm (1.97 in)	DN50: 53 mm (2.1 in)	
		DN65: 66 mm (2.6 in)	DN65: 70 mm (2.76 in)	
		DN80: 81 mm (3.2 in)	DN80: 85 mm (3.35 in)	DN80 to DN150: 10 bar (145 psi)
		DN100: 100 mm (3.94 in)	DN100: 104 mm (4.1 in)	
		DN125: 125 mm (4.92 in)	DN125: 129 mm (5.08 in)	
Type N, according to EN ISO 1127, series B	68 mm (2.67 in)	38.4 mm (1.51 in)	42.4 mm (1.67 in)	42.4 mm (1.67 in) to 60.3 mm (2.37 in): 16 bar (232 psi)
		44.3 mm (1.75 in)	48.3 mm (1.9 in)	

Type			Technical properties	
		56.3 mm (2.22 in)	60.3 mm (2.37 in)	76.1 mm (3 in) to 114.3 mm (4.5 in): 10 bar (145 psi)
		72.1 mm (2.84 in)	76.1 mm (3 in)	
		82.9 mm (3.26 in)	42.4 mm (3.5 in)	
		108.3 mm (4.26 in)	114.3 mm (4.5 in)	
Type N, according to DIN 11866, series C	68 mm (2.67 in)	OD 1½": 34.9 mm (1.37 in)	OD 1½": 38.1 mm (1.5 in)	OD 1½" to OD 2½": 16 bar (232 psi)
		OD 2": 47.2 mm (1.86 in)	OD 2": 50.8 mm (2 in)	
		OD 2½": 60.2 mm (2.37 in)	OD 2½": 63.5 mm (2.5 in)	
Type N, according to DIN 11866, series C	68 mm (2.67 in)	OD 3": 73 mm (2.87 in)	OD 3": 76.2 mm (3 in)	OD 3" to OD 4": 10 bar (145 psi)
		OD 4": 97.6 mm (3.84 in)	OD 4": 101.6 mm (4 in)	

Tee thermowell, optimized (no welding, no dead legs)

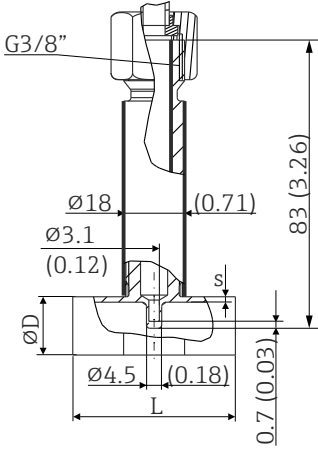
Type	Version	Dimensions in mm (in)			Technical properties	
		ØD	L	s ¹⁾		
Tee thermowell for weld-in as per DIN 11865 	Series A	DN10 PN25	13 mm (0.51 in)	48 mm (1.89 in)	1.5 mm (0.06 in)	P _{max.} = 25 bar (362 psi) ■ P _{max.} = 25 bar (362 psi) ■ 3-A marked and EHEDG certified ■ ASME BPE compliance
		DN15 PN25	19 mm (0.75 in)			
		DN20 PN25	23 mm (0.91 in)			
		DN25 PN25	29 mm (1.14 in)			
		DN32 PN25	32 mm (1.26 in)	67 mm (3.12 in)	2 mm (0.08 in)	■ P _{max.} = 16 bar (232 psi) ■ 3-A marked and EHEDG certified ■ ASME BPE compliance
		DN40 PN25	41 mm (1.61 in)			
		DN50 PN25	53 mm (2.09 in)			
		DN65 PN16	70 mm (2.76 in)			

1) Wall thickness

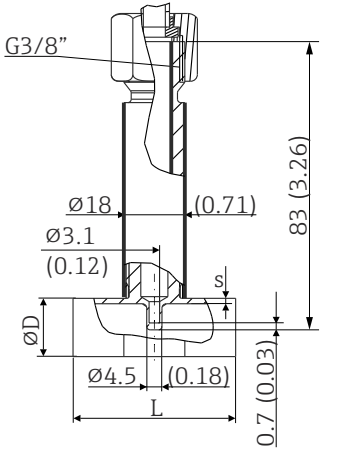
Type	Version		Dimensions in mm (in)			Technical properties
			ØD	L	s ¹⁾	
Tee thermowell for weld-in as per DIN 11865 	Series B	DN13.5 PN25	13.5 mm (0.53 in)	48 mm (1.89 in)	1.6 mm (0.063 in)	P _{max.} = 25 bar (362 psi)
		DN17.2 PN25	17.2 mm (0.68 in)			
		DN21.3 PN25	21.3 mm (0.84 in)			
		DN26.9 PN25	26.9 mm (1.06 in)			
		DN33.7 PN25	33.7 mm (1.33 in)	67 mm (3.12 in)	2 mm (0.08 in)	<ul style="list-style-type: none"> ■ P_{max.} = 25 bar (362 psi) ■ 3-A marked and EHEDG certified ■ ASME BPE compliance
		DN42.4 PN25	42.4 mm (1.67 in)			
		DN48.3 PN25	48.3 mm (1.9 in)			
		DN60.3 PN25	60.3 mm (2.37 in)			
		DN76.1 PN16	76.1 mm (3.0 in)			

1) Wall thickness

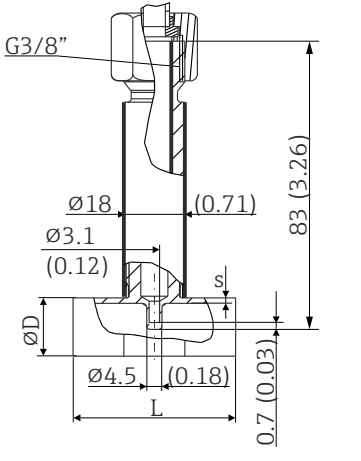
Type	Version		Dimensions in mm (in)			Technical properties
			ØD	L	s ¹⁾	
Tee thermowell for weld-in as per DIN 11865 	Series C	DN12.7 PN25 (½")	12.7 mm (0.5 in)	48 mm (1.89 in)	1.65 mm (0.065 in)	P _{max.} = 25 bar (362 psi)
		DN19.05 PN25 (¾")	19.05 mm (0.75 in)			
		DN25.4 PN25 (1")	25.4 mm (1 in)			
		DN38.1 PN25 (1½")	38.1 mm (1.5 in)	67 mm (3.12 in)	<ul style="list-style-type: none"> ■ P_{max.} = 25 bar (362 psi) ■ 3-A marked and EHEDG certified ■ ASME BPE compliance 	
		DN50.8 PN25 (2")	50.8 mm (2 in)			
		DN63.5 PN25 (2½")	63.5 mm (2.5 in)	71 mm (2.80 in)	<ul style="list-style-type: none"> ■ P_{max.} = 16 bar (232 psi) ■ 3-A marked and EHEDG certified ■ ASME BPE compliance 	
		DN76.2 PN16 (3")	76.2 mm (3 in)			
		DN101.6 PN12.5 (4")	101.6 mm (4 in)			
						2.11 mm (0.08 in)

1) Wall thickness

Elbow thermowell, optimized (no welding, no dead legs)

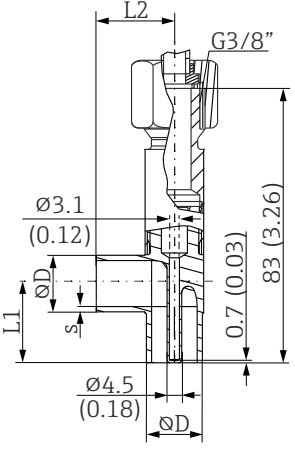
Type	Version		Dimensions				Technical properties
			ØD	L1	L2	s ¹⁾	
Elbow thermowell for weld-in as per DIN 11865 	Series A	DN10 PN25	13 mm (0.51 in)	24 mm (0.95 in)	1.5 mm (0.06 in)	P _{max.} = 25 bar (362 psi)	
		DN15 PN25	19 mm (0.75 in)	25 mm (0.98 in)			
		DN20 PN25	23 mm (0.91 in)	27 mm (1.06 in)			
		DN25 PN25	29 mm (1.14 in)	30 mm (1.18 in)			
		DN32 PN25	35 mm (1.38 in)	33 mm (1.3 in)			
		DN40 PN25	41 mm (1.61 in)	44.5 mm (1.75 in)			
		DN50 PN25	53 mm (2.09 in)	50.5 mm (1.99 in)			
		DN65 PN16	70 mm (2.76 in)	59.5 mm (2.34 in)	2.0 mm (0.08 in)	<ul style="list-style-type: none"> ■ P_{max.} = 16 bar (232 psi) ■ 3-A marked and EHEDG certified ■ ASME BPE compliance 	

1) Wall thickness

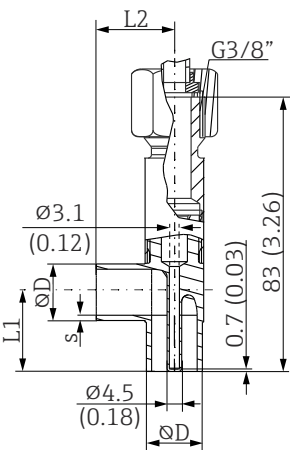
Type	Version		Dimensions				Technical properties
			ØD	L1	L2	s ¹⁾	
Elbow thermowell for weld-in as per DIN 11865 	Series B	DN13.5 PN25	13.5 mm (0.53 in)	32 mm (1.26 in)	1.6 mm (0.063 in)	P _{max.} = 25 bar (362 psi)	
		DN17.2 PN25	17.2 mm (0.68 in)	34 mm (1.34 in)			
		DN21.3 PN25	21.3 mm (0.84 in)	36 mm (1.41 in)			
		DN26.9 PN25	26.9 mm (1.06 in)	29 mm (1.14 in)	2.0 mm (0.08 in)	<ul style="list-style-type: none"> ■ P_{max.} = 25 bar (362 psi) ■ 3-A marked and EHEDG certified ■ ASME BPE compliance 	
		DN33.7 PN25	33.7 mm (1.33 in)	32 mm (1.26 in)			
		DN42.4 PN25	42.4 mm (1.67 in)	44.5 mm (1.75 in)			
		DN48.3 PN25	48.3 mm (1.9 in)	45.5 mm (1.79 in)			
		DN60.3 PN25	60.3 mm (2.37 in)	51.5 mm (2.03 in)			
		DN76.1 PN16	76.1 mm (3.0 in)	65 mm (2.56 in)		<ul style="list-style-type: none"> ■ P_{max.} = 16 bar (232 psi) ■ 3-A marked and EHEDG certified ■ ASME BPE compliance 	

1) Wall thickness

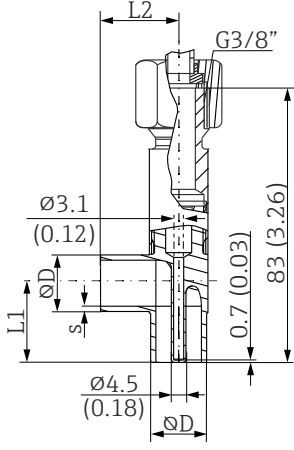
Type	Version	Dimensions			Technical properties
		ϕD	L1	L2	
Elbow thermowell for weld-in as per DIN 11865 	Series C	DN12.7 PN25 (1/2")	12.7 mm (0.5 in)	24 mm (0.95 in)	$P_{max.} = 25 \text{ bar (362 psi)}$
		DN19.05 PN25 (3/4")	19.05 mm (0.75 in)	25 mm (0.98 in)	
		DN25.4 PN25 (1")	25.4 mm (1 in)	28 mm (1.1 in)	
		DN38.1 PN25 (1 1/2")	38.1 mm (1.5 in)	35 mm (1.38 in)	
		DN50.8 PN25 (2")	50.8 mm (2 in)	51 mm (2 in)	
		DN63.5 PN25 (2 1/2")	63.5 mm (2.5 in)	58 mm (2.28 in)	
		DN76.2 PN16 (3")	76.2 mm (3 in)	65 mm (2.56 in)	$2.11 \text{ mm (0.08 in)}$ <ul style="list-style-type: none"> ■ $P_{max.} = 16 \text{ bar (232 psi)}$ ■ 3-A marked and EHEDG certified ■ ASME BPE compliance
	DN101.6 PN12.5 (4")	101.6 mm (4 in)	101.6 mm (4 in)	<ul style="list-style-type: none"> ■ $P_{max.} = 12.5 \text{ bar (181 psi)}$ ■ 3-A marked and EHEDG certified ■ ASME BPE compliance 	

1) Wall thickness

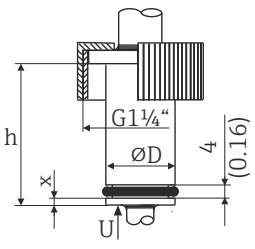
Type	Version, dimensions $\phi D \times h$	Technical properties
Ingold connection 	$\phi 25 \text{ mm (0.98 in)} \times 30 \text{ mm (1.18 in)}$ $x = 1.5 \text{ mm (0.06 in)}$	$P_{max.} = 25 \text{ bar (362 psi)}$ A seal is included in the scope of delivery. V75SR material: Complies with FDA, 3-A Sanitary Standard 18-03 Class 1 and USP Class VI
	$\phi 25 \text{ mm (0.98 in)} \times 46 \text{ mm (1.81 in)}$ $x = 6 \text{ mm (0.24 in)}$	

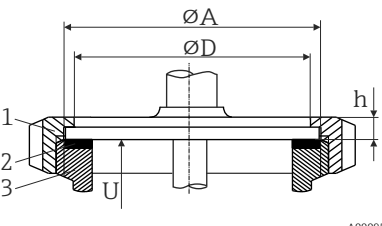
Type	Version	Dimensions			Technical properties
		ϕD	ϕA	h	
SMS 1147 	DN25	32 mm (1.26 in)	35.5 mm (1.4 in)	7 mm (0.28 in)	$P_{max.} = 6 \text{ bar (87 psi)}$
	DN38	48 mm (1.89 in)	55 mm (2.17 in)	8 mm (0.31 in)	
	DN51	60 mm (2.36 in)	65 mm (2.56 in)	9 mm (0.35 in)	

1 Coupling nut
2 Sealing ring
3 Counterpart connection

 The counterpart connection must fit the sealing ring and fix it in place.

Type	Version	Dimensions					Technical properties
		ϕA	ϕB	ϕD	ϕd	h	
<p>Neumo Biocontrol</p> <p>A0018497</p>	D25 PN16	64 mm (2.52 in)	50 mm (1.97 in)	30.4 mm (1.2 in)	7 mm (0.28 in)	20 mm (0.79 in)	<ul style="list-style-type: none"> ■ P_{max.} = 16 bar (232 psi) ■ 3-A marked
	D50 PN16	90 mm (3.54 in)	70 mm (2.76 in)	49.9 mm (1.97 in)	9 mm (0.35 in)	27 mm (1.06 in)	
	D65 PN25	120 mm (4.72 in)	95 mm (3.74 in)	67.9 mm (2.67 in)	11 mm (0.43 in)		



71619016

www.addresses.endress.com
