

Technical Information

Memosens CPS77E

ISFET sensor for pH measurement

Digital with Memosens 2.0 technology



Application

- Hygienic and sterile applications
- Food and pharmaceutical industry
- Biotechnology

With the following approvals for use in hazardous areas Zone 0, Zone 1 and Zone 2: ATEX, IECEx, CSA C/US, NEPSI, JPN Ex, INMETRO, UKCA and Korea Ex.

Your benefits

- Break-resistant
- Biocompatibility successfully tested with regard to biological reactivity in vitro (cytotoxicity) and in vivo in accordance with USP <87> and USP <88> Cl. VI (121 °C (250 °F))
- Sterilizable
- Longer calibration intervals than with pH glass electrodes
 - Shorter hysteresis in event of temperature change
 - Smaller measuring errors following exposure to high temperatures
 - Virtually no acid and alkaline errors
- Integrated Pt1000 temperature sensor for effective temperature compensation

Other advantages of Memosens technology

- Maximum process safety with non-contact, inductive signal transmission
- Data security thanks to digital data transmission
- Very easy to use as sensor data saved in the sensor
- Recording of sensor load data in the sensor enables predictive maintenance

Function and system design

Measuring principle

Ion-selective, or more generally, ion-sensitive field effect transistors (ISFET) were developed in the 1970s as an alternative to glass electrodes for pH measurement.

pH measurement with ISFET sensors

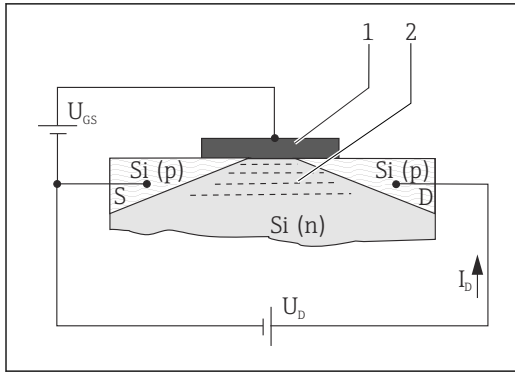
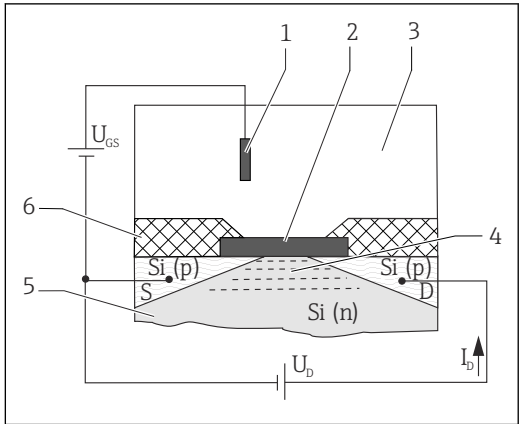
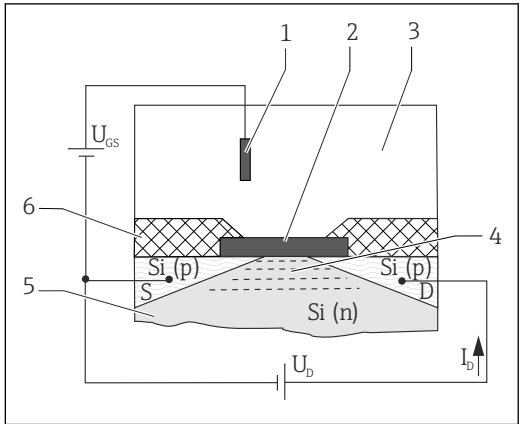
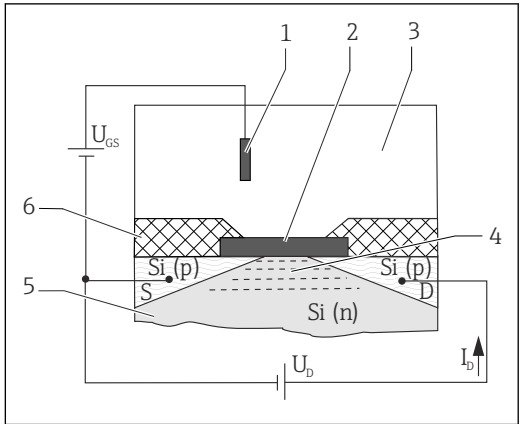
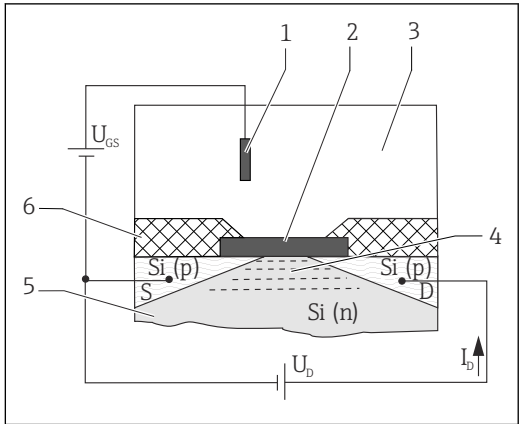
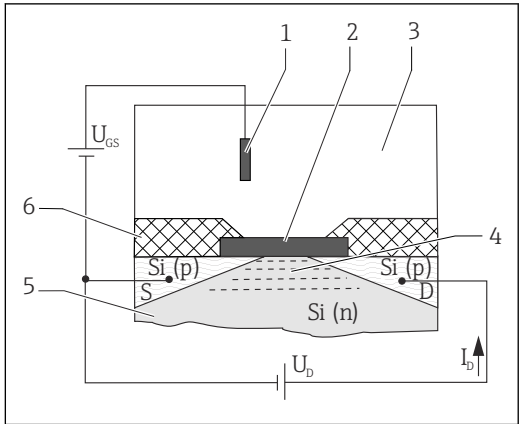
Ion-selective field effect transistors are based on an MOS¹⁾ transistor arrangement →  1,  2, but without the metal gate (item 1) as the control electrode. Instead, in the ISFET sensor, the medium (item 3) →  2,  2 is in direct contact with the gate insulator layer (item 2). Two highly p-conducting regions are diffused into the n-conducting substrate (item 5) of the semiconductor (Si). They act as the charge-supplying electrode ("Source", S) and the charge-accepting electrode ("Drain", D). The metal gate electrode (in the case of the MOSFET) and the medium (in the case of the ISFET) forms a capacitor with the underlying substrate. A difference in potential (voltage) between the gate and substrate (U_{GS}) increases the electron density in the area between the "Source" and "Drain". A conductive channel →  2,  2 (item 4) forms, such that a current I_D flows when a voltage U_D is applied.

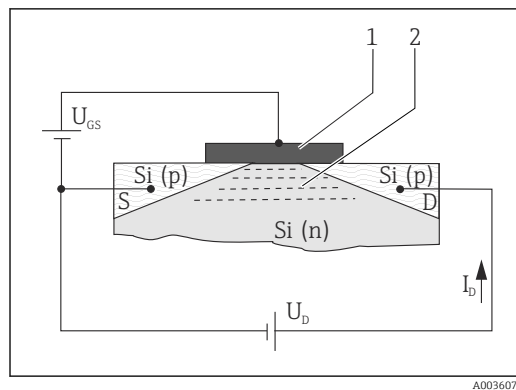

 1 MOSFET principle

- 1 Metal gate
- 2 Conductive channel (N-conducting)

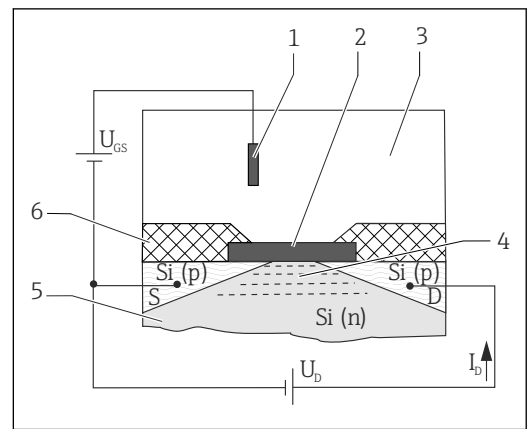

 2 ISFET principle

- 1 Reference electrode
- 2 Gate insulator layer
- 3 Medium
- 4 Conductive channel (N-conducting)
- 5 N-doped silicon substrate
- 6 Sensor shaft

With the ISFET, ions that are in the medium and located in the boundary layer between the medium/gate insulator generate the electric field (gate potential). The effect described above causes a conductive channel to form in the silicon semi-conductor substrate between the "Source" and "Drain", and causes current to flow between the "Source" and "Drain".

Suitable sensor circuits use the dependence of the ion-selective gate potential to generate an output signal that is proportional to the concentration of the ion type.

pH-selective ISFET

The gate insulator acts as an ion-selective layer for H^+ ions. While the gate insulator is also impermeable to these ions (insulator effect), it allows reversible surface reactions with H^+ ions. Depending on the acidic or alkaline character of the medium, functional groups in the insulator surface either accept or donate H^+ ions (amphoteric character of the functional groups). This results in positive charging at the insulator surface (H^+ ions accepted in the acidic medium) or negative charging at the insulator surface (H^+ ions donated in the alkaline medium). Depending on the pH value, a defined surface charge can be used to control the field effect in the channel between the "Source" and "Drain". The processes which lead to the creation of a charge potential and therefore to a control voltage U_{GS} between the "Gate" and "Source" are described by the Nernst equation:

$$U_{GS} = U_0 + \frac{2.3 \cdot RT}{nF} \cdot \lg a_{ion}$$

1) Metal oxide semiconductor

U_{GS}	Potential between gate and source	F	Faraday constant (26.803 Ah)
U_0	Offset voltage	a_{ion}	Activity of ion type (H^+)
R	Gas constant (8.3143 J/molK)	$\frac{2.3 \cdot RT}{nF}$	Nernst factor
T	Temperature [K]		
n	Valency (1/mol)		

At 25 °C (77 °F) the Nernst factor of the pH measurement has the value -59.16 mV/pH.

Measuring system

A complete measuring system comprises at least:

- ISFET sensor
- Memosens data cable CYK10
- Transmitter, e.g. Liquiline CM44x, Liquiline CM42
- Assembly
 - Immersion assembly, e.g. Dipfit CPA111
 - Flow assembly, e.g. Flowfit CPA250
 - Retractable assembly, e.g. Cleanfit CPA875
 - Permanent installation assembly, e.g. Unifit CPA842

Additional options are available depending on the application:

Automatic cleaning and calibration system, e.g.. Liquiline Control CDC90

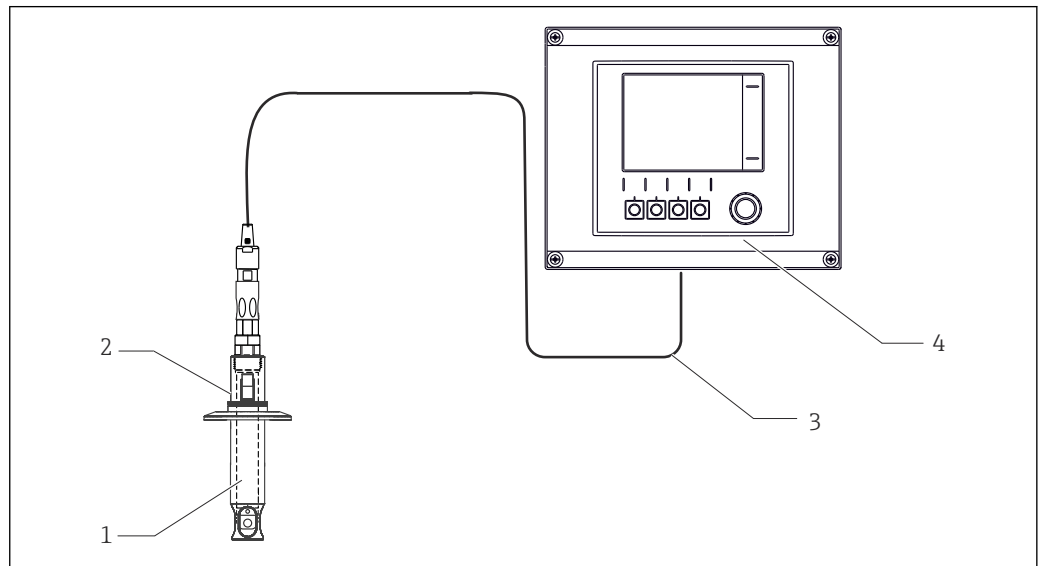

3 Example of a measuring system

- 1 ISFET sensor
- 2 Installation assembly Unifit CPA842
- 3 Memosens data cable CYK10
- 4 Liquiline CM42 transmitter

Communication and data processing**Communication with the transmitter**

 Always connect digital sensors with Memosens technology to a transmitter with Memosens technology. Data transmission to a transmitter for analog sensors is not possible.

Digital sensors can store measuring system data in the sensor. These include the following:

- Manufacturer data
 - Serial number
 - Order code
 - Date of manufacture
- Calibration data
 - Calibration date
 - Slope at 25 °C (77 °F)
 - Operating point at 25 °C (77 °F)
 - Offset of integrated temperature sensor
 - Number of calibrations
 - Calibration history
 - Serial number of the transmitter used to perform the last calibration or adjustment
- Operating data
 - Temperature application range
 - pH application range
 - Date of initial commissioning
 - Maximum temperature value
 - Hours of operation under extreme conditions
 - Number of sterilizations
 - CIP counter
 - Sensor load

The data listed above can be displayed with Liquiline CM42, CM44x, and Memobase Plus CYZ71D.

Dependability**Reliability****Easy handling**

Sensors with Memosens technology have integrated electronics that store calibration data and other information (e.g. total hours of operation or operating hours under extreme measuring conditions). Once the sensor has been connected, the sensor data are transferred automatically to the transmitter and used to calculate the current measured value. As the calibration data are stored in the sensor, the sensor can be calibrated and adjusted independently of the measuring point. The result:

- Easy calibration in the measuring lab under optimum external conditions increases the quality of the calibration.
- Pre-calibrated sensors can be replaced quickly and easily, resulting in a dramatic increase in the availability of the measuring point.
- Thanks to the availability of the sensor data, maintenance intervals can be accurately defined and predictive maintenance is possible.
- The sensor history can be documented on external data carriers and evaluation programs.
- The saved application data of the sensor can be used to determine the continued use of the sensor in a targeted manner.

Interference immunity**Data security thanks to digital data transmission**

Memosens technology digitizes the measured values in the sensor and transmits the data to the transmitter via a non-contact connection that is free from potential interference. The result:

- If the sensor fails or there is an interruption in the connection between the sensor and transmitter, this is reliably detected and reported.
- The availability of the measuring point is reliably detected and reported.

Safety

Maximum process safety

With inductive transmission of the measured value using a non-contact connection, Memosens guarantees maximum process safety and offers the following benefits:

- All problems caused by moisture are eliminated:
 - No corrosion at the connection
 - Measured values cannot be distorted by moisture
- The transmitter is galvanically decoupled from the medium. Issues concerning "symmetrical high-impedance" or "asymmetry" or the type of impedance converter are a thing of the past.
- Electromagnetic compatibility (EMC) is guaranteed by screening measures for the digital transmission of measured values.
- Intrinsically safe electronics mean operation in hazardous areas is not a problem. Complete flexibility thanks to individual Ex approvals for all components, such as sensors, cables and transmitters.

Input

Measured variable	pH value Temperature
Measuring range	<ul style="list-style-type: none"> ■ pH: 0 to 14 ■ Temperature: -15 to 135 °C (5 to 275 °F) <p> Pay attention to the operating conditions in the process.</p>

Power supply

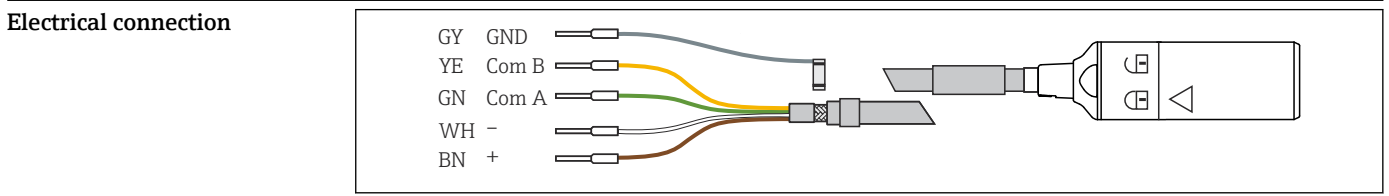

 4 *Measuring cable CYK10 or CYK20*

- ▶ Connect the Memosens measuring cable, e.g. CYK10 or CYK20, to the sensor.

 For further information on cable CYK10, see BA00118C.

Performance characteristics

Reference operating conditions	Reference temperature: 25 °C (77 °F) Reference pressure: 1013 hPa (15 psi)
Reference system	Ag/AgCl reference lead, bridging electrolyte: liquid KCl, 3M, AgCl-free
Hysteresis	Another important advantage over pH glass electrodes is the lower acid or alkaline errors in extreme pH ranges. In contrast to the pH glass electrode, almost no foreign ions can build up at the ISFET gate. Between pH 1 and pH 13, the measured error averages Δ pH 0.02 (at 25 °C (77 °F)) and is therefore at the detection limit.

The following graphic shows the average measured error of the ISFET sensor in the pH 1 to 13 range and compared with two pH glass electrodes (two different pH glasses) at the extreme values of pH 0.09 (1 M HCl) and 13.86 (1 M NaOH).

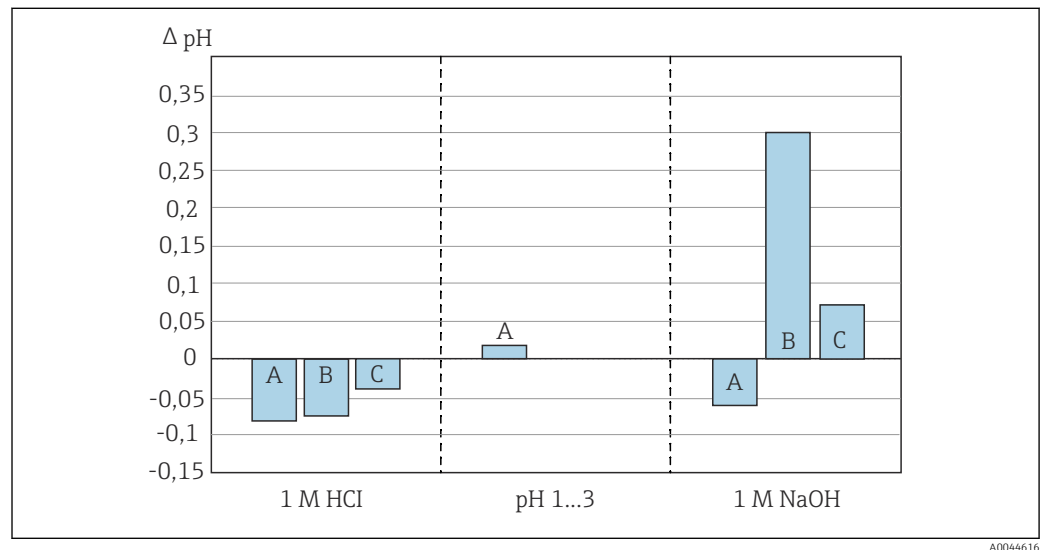

5 Measured errors of the ISFET sensor compared to different pH sensors

- A ISFET
- B Glass type A
- C Glass type B

Repeatability ± 0.01 pH

Response time A closed-control loop is created each time the measuring system is switched on. The measured value adjusts to the real value during this time.

The settling time depends on the type and duration of the interruption:

- Voltage interruption, sensor remains in the medium: 3-5 minutes
- Interruption of the film of liquid between the ISFET and reference: 5-8 minutes
- Dry storage of the sensor for an extended period: up to 30 minutes

Response time The response times of the sensor are extremely short over the entire temperature range. There is no (temperature-dependent) equilibrium setting. This means it can also be used at low temperatures without a deceleration in the response time.

Response time t_{90}

$t < 5$ seconds, for a buffer change from pH 4 to pH 7 and under reference operating conditions

i The response of the integrated temperature sensor can be slower in the event of extreme temperature changes. In this case, regulate the temperature of the sensor before a calibration or measurement.

Mounting

- Orientation**
1. Note the direction of medium flow when installing the sensor.
 2. Position the ISFET chip at an angle of approx. 30 to 45 ° to the direction of flow (item 2) → 7, 7. Use the rotatable terminal head for this purpose.

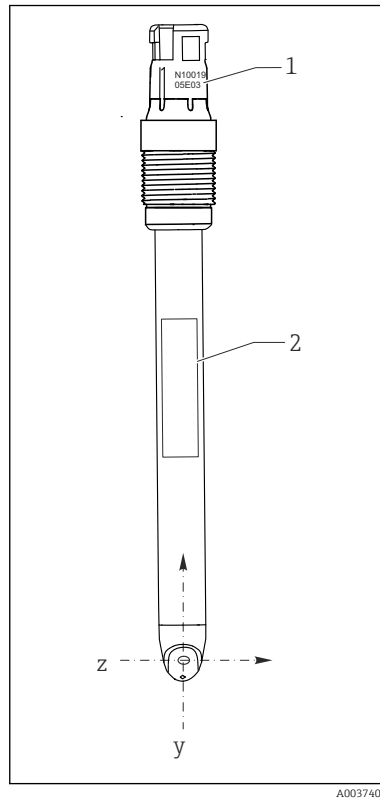

6 Sensor orientation, front view

- 1 Serial number
- 2 Nameplate

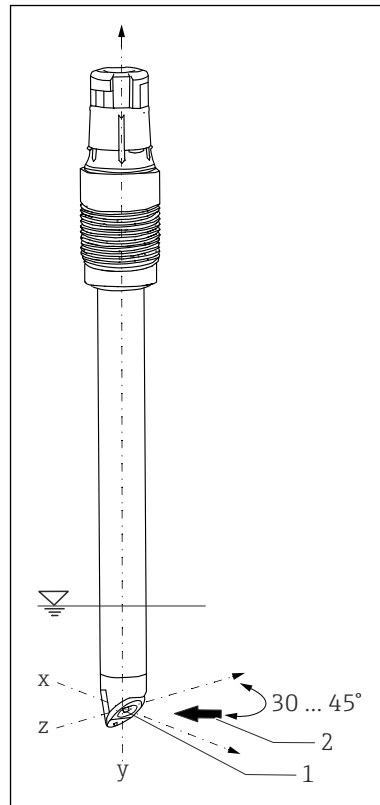

7 Sensor orientation, 3D view

- 1 ISFET chip
- 2 Direction of medium flow

When installing the sensor in an assembly, the serial number engraved on the plug-in head can be used as a guide when aligning the sensor → 6, 7. The engraving is always on the same plane as the ISFET chip and the nameplate (z-y direction).

ISFET sensors are not designed for use in abrasive media.

- ▶ If these sensors are used in such applications, avoid direct flow to the chip.
 - ↳ The disadvantage is that the pH value displayed is not stable.

ISFET sensors can be installed in any position because there is no liquid internal lead. However, if installed upside down, the possibility of an air bubble in the reference system interrupting the electrical contact between the medium and the junction or cannot be ruled out.

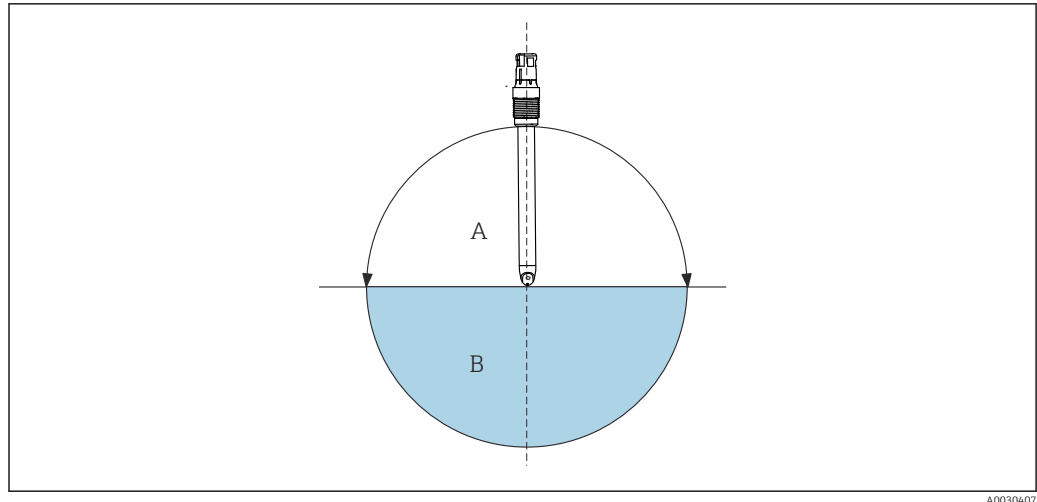

8 Angle of installation

A Recommended

B Permitted, pay attention to basic conditions → 7

Basic conditions: The sensor is delivered from the factory free of air bubbles. Air bubbles occur, however, when working with a vacuum, e.g. when emptying a tank.

- ▶ Leave the installed sensor in dry conditions for a maximum of 6 hours (also applies to upside-down installation).

Installation instructions



Follow the Operating Instructions for the assembly used for detailed information on installing the assembly.

1. Before screwing in the sensor, make sure the assembly thread, the O-rings and the sealing surface are clean and undamaged and that the thread runs smoothly.
2. Hand-tighten the sensor with a torque of 3 Nm (2.21 lbf ft) (Only applies when installing in Endress+Hauser assemblies).

For detailed information on removing the wetting cap, see BA02154C

Hygienic requirements

Devices in hygienic applications place specific demands on the installation. These must be taken into account in order to guarantee hygienic operation without contamination of the process medium.



Special Documentation for hygienic applications, SD02751C

For 3-A- or EHEDG-compliant and easy-clean installation, please observe the following:

- Use a certified process assembly
- Use a process assembly with a protective guard around the sensor
- The installation must be self-draining
- Dead areas should be avoided



It is recommended to change the sensor after 40 CIP cycles.

Environment

Ambient temperature range

NOTICE

Risk of damage from frost!

- ▶ Do not use the sensor at temperatures below -15 °C (5 °F).

Storage temperature

0 to 50 °C (32 to 122 °F)

Sensitivity to light

NOTICE

Direct sunlight during calibration and operation

Measured value fluctuations!

- ▶ Avoid direct sunlight during calibration and operation.

Like all semiconductor components, the ISFET chip is sensitive to light. Normal ambient light does not have any significant effect on the measurement.

Degree of protection

IP 68 (10 m (33 ft) water column, 25 °C (77 °F), 45 days, up to 135 °C (275 °F))

Electromagnetic compatibility (EMC)

Interference emission and interference immunity as per



- EN 61326-1:2013
- EN 61326-2-3:2013
- NAMUR NE21: 2012

Process

Process temperature range

-15 to 135 °C (5 to 275 °F)

Medium temperature depending on the pH value

At high temperatures, alkalis can irreversibly damage the gate insulator oxide over the longer term. The sensor can only be used in the marked range (→  9,  9) to the detriment of the sensor operating life. If permanently exposed to 1 molar NaOH at temperatures over 65 °C (149 °F), the sensor operating life is reduced to such an extent that permanent operation in this range is not recommended.

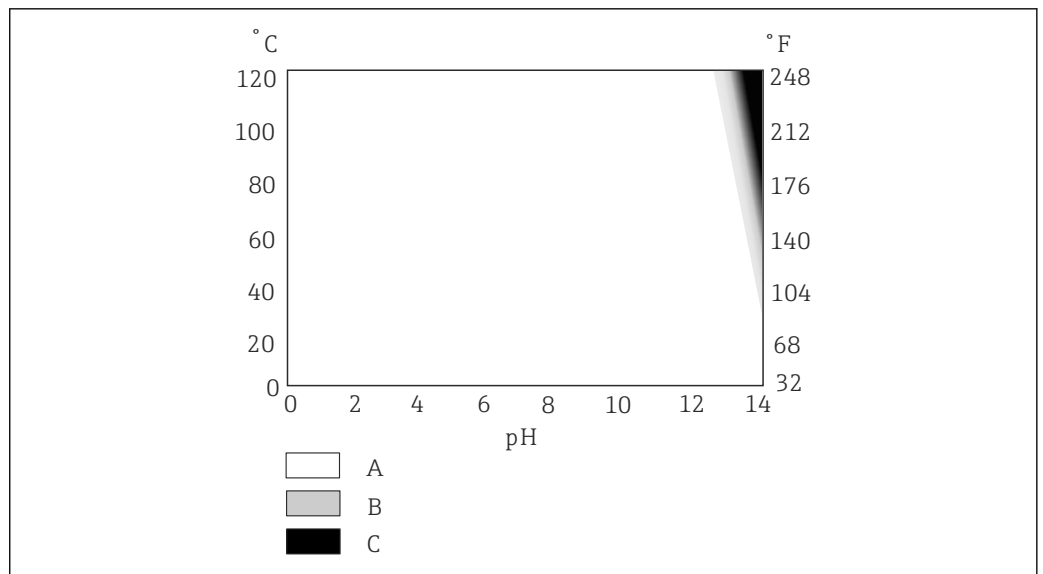

 9 Area of application depending on the temperature and pH value

- A Can be used without any problems
- B Limited operating life
- C Use not recommended

Process pressure range

0.8 to 11 bar (11.6 to 159.5 psi) (absolute)

Conductivity

Minimum conductivity²⁾: 50 µS/cm

2) Reference conditions: Demineralized water as the measuring medium whose conductivity has been adjusted with NaOH, KCl or HCl; room temperature; unpressurized sensor operation; change between stationary medium and flow of medium to the sensor with 2 m/s (6.6 ft/s) fluid velocity with lateral medium flow in the direction of the ISFET chip; the conductivity value indicated is the value determined when the measured value changes by less than 0.2 pH in all media between stationary media and flowing media.

Pressure-temperature ratings

NOTICE

Risk of damage to the sensor!

▶ Never use the sensor outside of the listed specifications.

Maximum 11 bar (160 psi) (absolute) / 100 °C (212 °F)

Sterilizable: 4 bar (58 psi) (absolute) / 135 °C (275 °F), 1 h

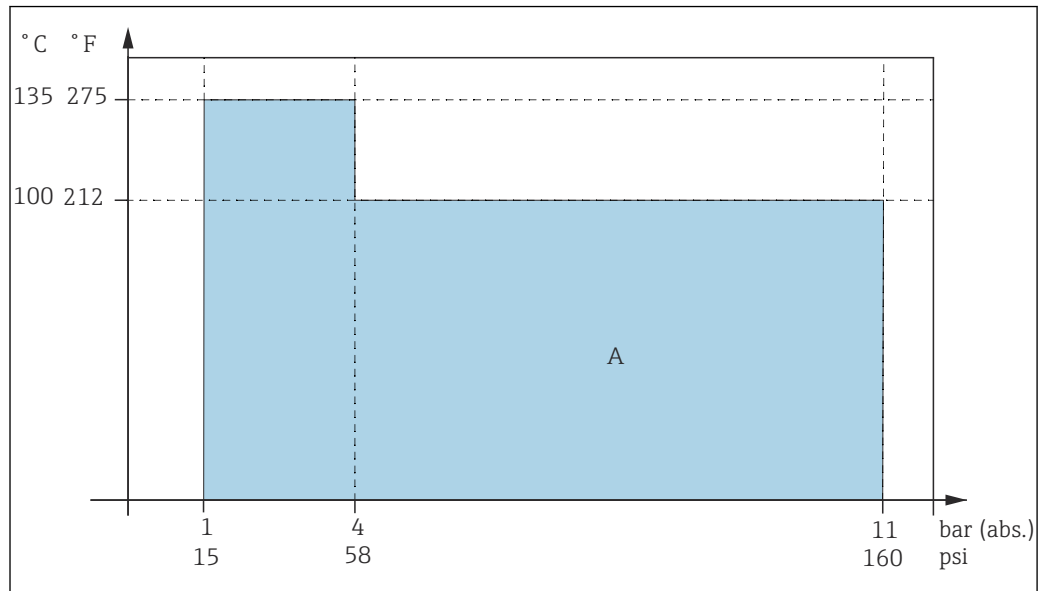

A0044851

10 Pressure/temperature rating

A Area of application

Mechanical construction

Design, dimensions

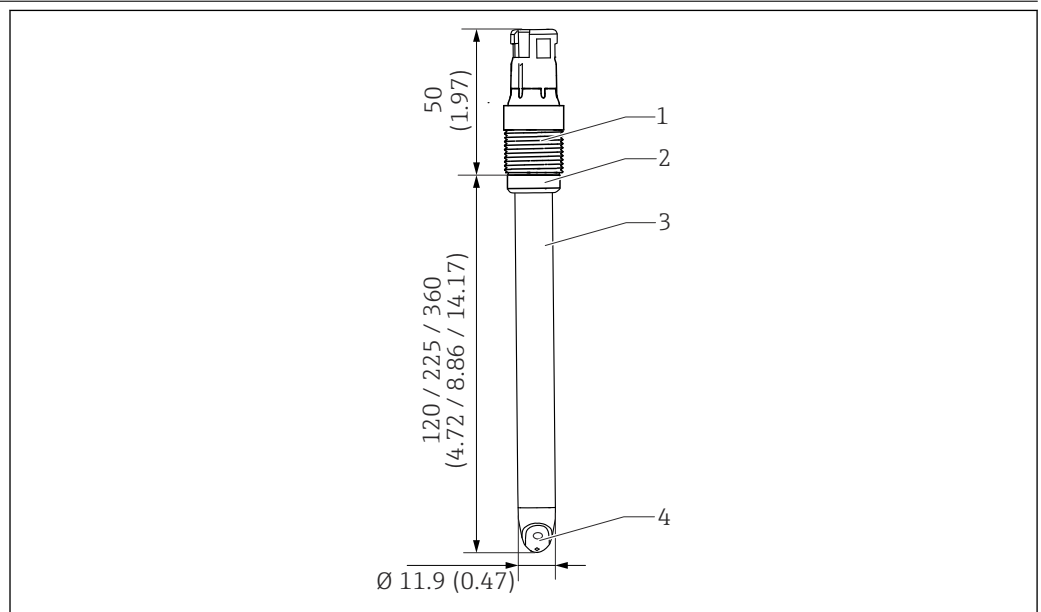

A0046470

11 Sensor with Memosens plug-in head. Engineering unit: mm (in)

- 1 Memosens plug-in head with process connection
- 2 O-ring with thrust collar
- 3 Sensor shaft
- 4 ISFET chip

Weight	Installed length	120 mm (4.72 in)	225 mm (8.86 in)	360 mm (14.17 in)
	Weight	35 g (1.2 oz)	50 g (1.8 oz)	66 g (2.3 oz)

Materials	Sensor shaft	PEEK
	Seal	FFKM
	Metal lead	Ag/AgCl
	O-ring on thrust collar	FKM
	Adhesive	Epoxy resin
	ISFET chip	Metal oxide based on tantalum pentoxide
	Junction	Ceramic junction, zirconium dioxide
	Process coupling	PPS, fiberglass-reinforced

Resistance to breaking

The sensor's resistance to breaking is its most distinctive external feature. The entire sensor technology is embedded in a PEEK shaft. Only the highly durable ISFET chip and the reference are in direct contact with the medium.

Temperature sensor	Pt1000 (Class A according to DIN IEC 60751)
Plug-in head	Memosens plug-in head for digital, non-contact data transmission, pressure resistance 16 bar (232 psi) (relative)
Process connections	Pg 13.5
Surface roughness	R _a < 0.76 µm (30 µin)

Certificates and approvals

Current certificates and approvals for the product are available at www.endress.com on the relevant product page:

1. Select the product using the filters and search field.
2. Open the product page.
3. Select **Downloads**.

Order information

Scope of delivery	<p>The scope of delivery comprises:</p> <ul style="list-style-type: none"> ■ Ordered version of the sensor ■ Operating Instructions ■ Safety instructions for the hazardous area (for sensors with Ex approval) ■ Supplementary sheet for optionally ordered certificates
Product page	www.endress.com/cps77e
Product Configurator	<ol style="list-style-type: none"> 1. Configure: Click this button on the product page. 2. Select Extended selection. <ul style="list-style-type: none"> ↳ The Configurator opens in a separate window. 3. Configure the device according to your requirements by selecting the desired option for each feature. <ul style="list-style-type: none"> ↳ In this way, you receive a valid and complete order code for the device.

4. **Accept:** Add the configured product to the shopping cart.

 For many products, you also have the option of downloading CAD or 2D drawings of the selected product version.

5. **CAD:** Open this tab.

↳ The drawing window is displayed. You have a choice between different views. You can download these in selectable formats.

Accessories

The following are the most important accessories available at the time this documentation was issued.

Listed accessories are technically compatible with the product in the instructions.

1. Application-specific restrictions of the product combination are possible. Ensure conformity of the measuring point to the application. This is the responsibility of the operator of the measuring point.
2. Pay attention to the information in the instructions for all products, particularly the technical data.
3. For accessories not listed here, please contact your Service or Sales Center.

Device-specific accessories

Assemblies

Unifit CPA842

- Installation assembly for food, biotechnology and pharmaceuticals
- With EHEDG and 3A certificate
- Product Configurator on the product page: www.endress.com/cpa842



Technical Information TI00306C

Cleanfit CPA875

- Retractable process assembly for sterile and hygienic applications
- For in-line measurement with standard sensors with 12 mm diameter, e.g. for pH, ORP, oxygen
- Product Configurator on the product page: www.endress.com/cpa875



Technical Information TI01168C

Dipfit CPA111

- Immersion and installation assembly made of plastic for open and closed vessels
- Product Configurator on the product page: www.endress.com/cpa111



Technical Information TI00112C

Cleanfit CPA871

- Flexible process retractable assembly for water, wastewater and the chemical industry
- For applications with standard sensors with 12 mm diameter
- Product Configurator on the product page: www.endress.com/cpa871



Technical Information TI01191C

Cleanfit CPA450

- Manual retractable assembly for installing sensors with a diameter of 12 mm and a length of 120 mm in tanks and pipes
- Product Configurator on the product page: www.endress.com/cpa450



Technical Information TI00183C

Flowfit CPA250

- Flow assembly for pH/ORP measurement
- Product Configurator on the product page: www.endress.com/cpa250



Technical Information TI00041C

Cleaning and calibration system

Liquiline Control CDC90

- Fully automatic cleaning and calibration system for pH and ORP measuring points in all industries
- Cleaned, validated, calibrated and adjusted
- Product Configurator on the product page: www.endress.com/cdc90



Technical Information TI01340C

Buffer solutions

High-quality buffer solutions from Endress+Hauser - CPY20

The secondary buffer solutions have been referenced to primary reference material of the PTB (German Federal Physico-technical Institute) or to standard reference material of NIST (National Institute of Standards and Technology) according to DIN 19266 by a laboratory accredited by the DAkkS (German accreditation body) according to DIN 17025.

Product Configurator on the product page: www.endress.com/cpy20

Measuring cable

Memosens data cable CYK10

- For digital sensors with Memosens technology
- Product Configurator on the product page: www.endress.com/cyk10



Technical Information TI00118C

Memosens laboratory cable CYK20

- For digital sensors with Memosens technology
- Product Configurator on the product page: www.endress.com/cyk20

Handheld instrument

Liquiline Mobile CML18

- Multiparameter mobile device for laboratory and field
- Reliable transmitter with display and app connection
- Product Configurator on the product page: www.endress.com/CML18



Operating Instructions BA02002C





www.addresses.endress.com
