



# Brief Operating Instructions Waterpilot FMX11

## Hydrostatic level measurement

These Brief Operating Instructions are not a substitute for the Operating Instructions pertaining to the device.

Detailed information is provided in the Operating Instructions and other documentation.

Available for all device versions via:

- Internet: [www.endress.com/deviceviewer](http://www.endress.com/deviceviewer)
- Smartphone/tablet: Endress+Hauser Operations app

## Basic safety instructions

### Requirements for personnel

The personnel must fulfill the following requirements for its tasks:

- ▶ Trained, qualified specialists must have a relevant qualification for this specific function and task.
- ▶ Personnel must be authorized by the plant owner/operator.
- ▶ Personnel must be familiar with federal/national regulations.
- ▶ Before starting work: personnel must read and understand the instructions in the manual and supplementary documentation as well as the certificates (depending on the application).
- ▶ Personnel must follow instructions and comply with general policies.

### Intended use

The Waterpilot FMX11 is a hydrostatic pressure sensor for level measurement, for example, in the area of untreated water extraction and drinking water storage.

### Workplace safety

When working on and with the device:

- ▶ Wear the required personal protective equipment as per national regulations.
- ▶ Switch off the supply voltage before connecting the device.

## Mounting

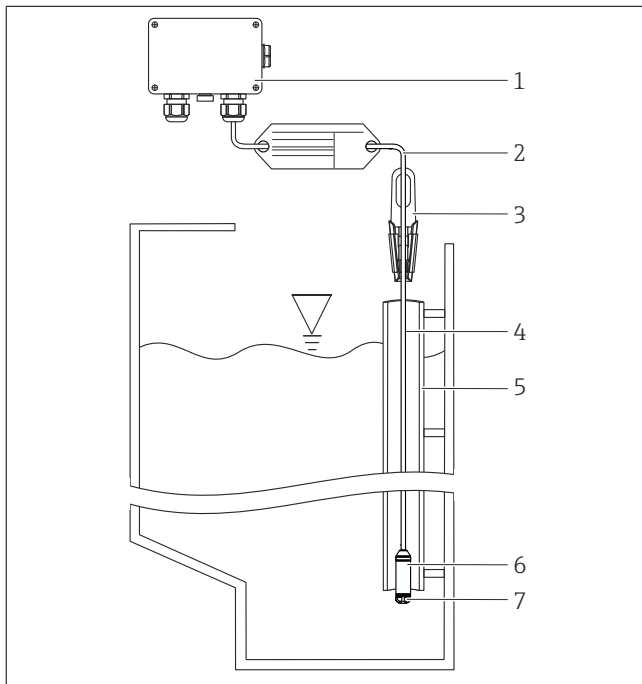

- 1 Terminal box can be ordered separately
- 2 Bending radius of extension cable  $\geq 70$  mm (2.76 in) (static)
- 3 Suspension clamp can be ordered as an accessory
- 4 Extension cable, cable length
- 5 Guide pipe
- 6 Waterpilot FMX11
- 7 Protective cap

### Mounting the Waterpilot with a mounting clamp

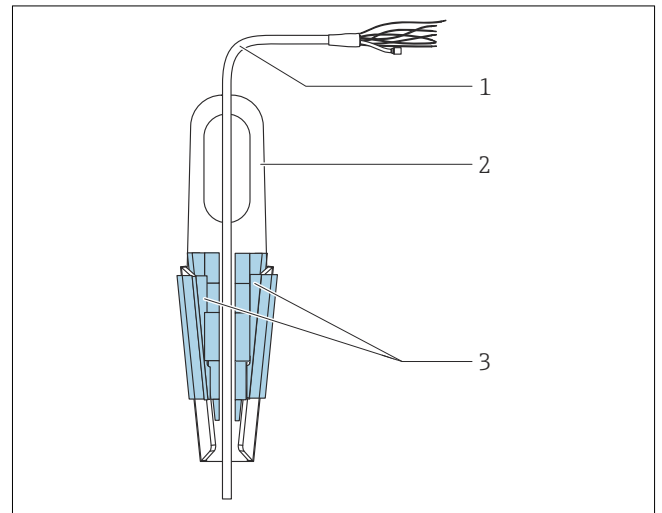

- 1 Extension cable
- 2 Suspension clamp
- 3 Clamping jaws

1. Mount the suspension clamp (item 2). Take the weight of the extension cable (item 1) and the device into account when selecting the fastening point.
2. Push up the clamping jaws (item 3). Place the extension cable (item 1) between the clamping jaws as shown in the graphic.

3. Hold the extension cable (item 1) in position and push the clamping jaws (item 3) back down. Tap the clamping jaws gently from above to fix them in place.

### Mounting the terminal box

The optional terminal box is mounted using four screws (M4). For the dimensions of the terminal box, see the Technical Information.

## Electrical connection

### ⚠ WARNING

#### An incorrect connection compromises electrical safety!

- ▶ The supply voltage must match the supply voltage specified on the nameplate.
- ▶ Switch off the supply voltage before connecting the device.
- ▶ The cable must end in a dry room or a suitable terminal box. The IP66/IP67 terminal box with GORE-TEX® filter from Endress+Hauser is suitable for outdoor installation.
- ▶ Connect the device in accordance with the following diagrams. Changing the polarities will not result in the destruction of the devices.
- ▶ A suitable circuit breaker should be provided for the device in accordance with IEC/EN 61010.

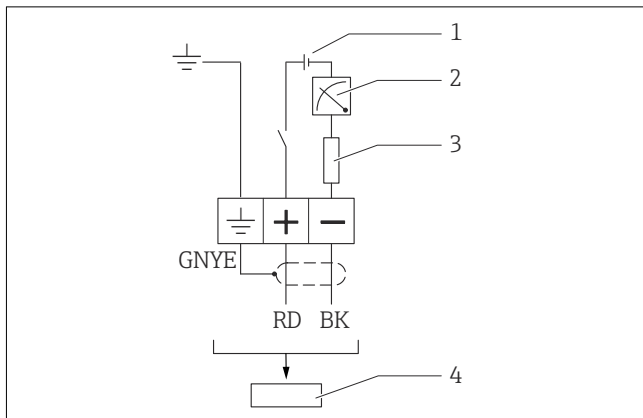

- 1 8 to 28 V<sub>DC</sub>
- 2 4 to 20 mA
- 3 Resistance (R<sub>L</sub>)
- 4 Waterpilot FMX11

### Wire colors

RD = red, BK = black, GNYE = green/yellow

### Connection data

Connection classification as per IEC 61010-1:

- Overvoltage category 1
- Pollution level 1