



Brief Operating Instructions iTEMP TMT31

Temperature transmitter



These Brief Operating Instructions are not a substitute for the Operating Instructions pertaining to the device. Detailed information can be found in the Operating Instructions and the additional documentation.

Available for all device versions via:

- Internet: www.endress.com/deviceviewer
- Smartphone/tablet: Endress+Hauser Operations app

Basic safety instructions

Manufacturer: Endress+Hauser Wetzlar GmbH + Co. KG, Obere Wank 1, D-87484 Nesselwang or www.endress.com

Requirements for the personnel

The personnel for installation, commissioning, diagnostics and maintenance must fulfil the following requirements:

- ▶ Trained, qualified specialists: must have a relevant qualification for this specific function and task
- ▶ Are authorized by the plant owner/operator
- ▶ Are familiar with federal/national regulations
- ▶ Before beginning work, the specialist staff must have read and understood the instructions in the manuals and supplementary documentation as well as in the certificates (depending on the application)
- ▶ Follow instructions and comply with basic conditions

The operating personnel must fulfil the following requirements:

- ▶ Are instructed and authorized according to the requirements of the task by the plant operator
- ▶ Follow the instructions in this manual

Intended use

The device is a universal and configurable temperature transmitter with a sensor input for resistance thermometers (RTD). The head transmitter version of the device is intended for mounting in a terminal head (flat face) as per DIN EN 50446. It is also possible to mount the device on a DIN rail using the optional DIN rail clip.

Workplace safety

When working on and with the device:

- ▶ Wear the required personal protective equipment as per national regulations.

Operational safety

- ▶ Operate the device only if it is in proper technical condition, free from errors and faults.
- ▶ The operator is responsible for trouble-free operation of the device.

Hazardous area

To eliminate a danger for persons or for the facility when the device is used in the hazardous area (e.g. explosion protection or safety equipment):

- ▶ Based on the technical data on the nameplate, check whether the ordered device is permitted for the intended use in the hazardous area. The nameplate can be found on the side of the transmitter housing.
- ▶ Comply with the instructions in the separate supplementary documentation, which is an integral part of this manual.

NOTICE

- ▶ The device must be powered only by a power unit that operates using a limited-energy circuit in accordance with UL/EN/IEC 61010-1, Section 9.4 and the requirements in Table 18.

Product safety

This product is designed in accordance with good engineering practice to meet state-of-the-art safety requirements and has been tested and left the factory in a condition in which it is safe to operate.

Mounting

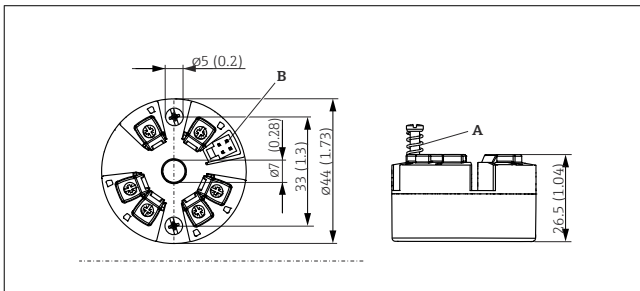

1 Head transmitter version with screw terminals. Dimensions in mm (in)

A Spring travel $L \geq 5$ mm (not for US - M4 securing screws)

B CDI interface for connecting a configuration tool



The same dimensions apply to the version with push-in terminals. Exception: Height of housing $H = 30$ mm (1.18 in).

Mounting the device

A Phillips head screwdriver is required to mount the head transmitter:

- ▶ Maximum torque for securing screws = 1 Nm (¾ foot-pound), screwdriver: Pozidriv Z2
- ▶ Maximum torque for screw terminals = 0.35 Nm (¼ foot-pound), screwdriver: Pozidriv Z1

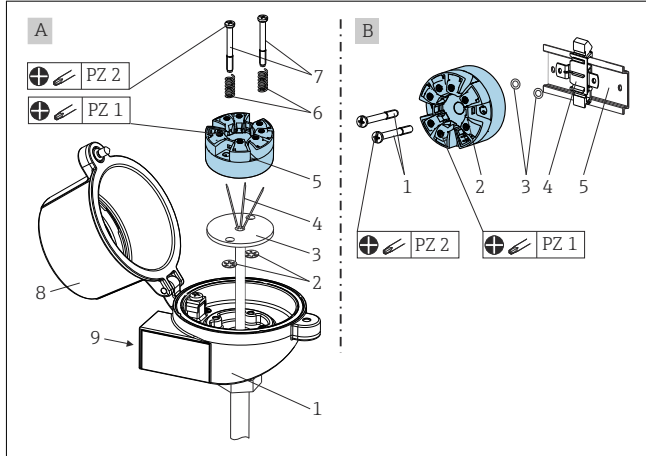

A Terminal head in accordance with DIN EN 50446 form B, direct installation onto insert with cable entry (middle hole 7 mm (0.28 in))
 B With DIN rail clip on DIN rail as per IEC 60715 (TH35)

Procedure for mounting in a terminal head, item A:

1. Open the terminal head cover (8) on the terminal head.
2. Guide the connection wires (4) of the insert (3) through the center hole in the head transmitter (5).
3. Fit the mounting springs (6) on the mounting screws (7).

Electrical connection

CAUTION

- ▶ Switch off the power supply before installing or connecting the device. Non-compliance may result in the destruction of parts of the electronics.
- ▶ Do not occupy the CDI connection. An incorrect connection can destroy the electronics.

NOTICE

- ▶ ⚠ ESD - Electrostatic discharge. Protect the terminals from electrostatic discharge. Non-compliance may result in the destruction or malfunction of parts of the electronics.

Connecting requirements

A Phillips head screwdriver is required to wire the head transmitter with screw terminals. The push-in terminal version can be wired without any tools.
 Maximum torque for screw terminals = 0.35 Nm (¼ lbf ft), screwdriver: Pozidriv Z1

Proceed as follows to wire a mounted head transmitter:

1. Open the cable gland and the housing cover on the terminal head or the field housing.
2. Feed the cables through the opening in the cable gland.
3. Connect the cables as shown in the graphic.
4. Tighten the cable gland again and close the housing cover.

Maintenance and cleaning

No special maintenance work is required for the device.

4. Guide the mounting screws (7) through the side boreholes of the head transmitter and the insert (3). Then fix both mounting screws with the snap rings (2).
5. Then tighten the head transmitter (5) along with the insert (3) in the terminal head.
6. After wiring, close the terminal head cover (8) tightly again.

i When installing the device in a terminal head, make sure there is enough space in the terminal head!

Procedure for mounting on a DIN rail, item B:

1. Press the DIN rail clip (4) onto the DIN rail (5) until it engages with a click.
2. Guide the mounting screws (1) through the side boreholes of the head transmitter (2) and secure with the retaining rings (3).
3. Screw the head transmitter (2) onto the DIN rail clip (4).

Important ambient conditions

Ambient temperature range	-40 to +85 °C (-40 to 185 °F)	Storage temperature	-50 to +100 °C (-58 to +212 °F)
Degree of protection	IP 20. When installed, the degree of protection depends on the terminal head.	Overvoltage category	II
Pollution degree	2	Humidity	Max. rel. humidity: 95 %
Altitude	≤ 4 000 m (4 374.5 ft)	Insulation class	Class III

Connecting the device

Supply voltage	Values for non-hazardous areas, protected against polarity reversal: U = 10 to 36 V _{DC}
Current consumption	I ≤ 22.5 mA

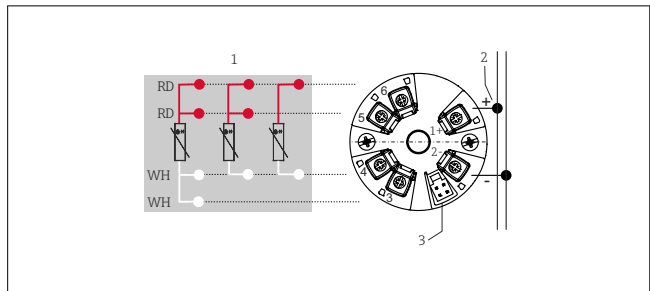

2 Terminal assignment of head transmitter

- 1 RTD sensor input: 4-, 3- and 2-wire
- 2 Power supply
- 3 CDI interface

A clean, dry cloth can be used to clean the device.