

# Safety Instructions

## Deltabar FMD71, FMD72

4-20 mA HART

Ex ia IIC T6...T3 Ga/Gb





# Deltabar FMD71, FMD72

4-20 mA HART

## Table of contents

Associated documentation .....	4
Supplementary documentation .....	4
Certificates and declarations .....	4
Manufacturer address .....	4
Extended order code .....	4
Safety instructions: General .....	6
Safety instructions: Specific conditions of use .....	6
Safety instructions: Installation .....	7
Safety instructions: Zone 0 .....	8
Temperature tables .....	9
Connection data .....	9

**Associated documentation**

To commission the device, please observe the Operating Instructions pertaining to the device:  
BA01044P

**Supplementary documentation**

Explosion protection brochure: CP00021Z  
The explosion protection brochure is available on the Internet:  
[www.endress.com/Downloads](http://www.endress.com/Downloads)

**Certificates and declarations****NEPSI Declaration of Conformity**

Certificate number:  
GYJ24.1051X

Affixing the certificate number certifies conformity with the following standards (depending on the device version):

- GB/T 3836.1-2021
- GB/T 3836.4-2021
- GB3836.20-2010

**Manufacturer address**

Endress+Hauser SE+Co. KG  
Hauptstraße 1  
79689 Maulburg, Germany  
Address of the manufacturing plant: See nameplate.

**Extended order code**

The extended order code is indicated on the nameplate, which is affixed to the device in such a way that it is clearly visible. Additional information about the nameplate is provided in the associated Operating Instructions.

**Structure of the extended order code**

FMD7x	–	*****	+	A*B*C*D*E*F*G*..
<i>(Device type)</i>		<i>(Basic specifications)</i>		<i>(Optional specifications)</i>

\* = Placeholder

At this position, an option (number or letter) selected from the specification is displayed instead of the placeholders.

### Basic specifications

The features that are absolutely essential for the device (mandatory features) are specified in the basic specifications. The number of positions depends on the number of features available. The selected option of a feature can consist of several positions.

### Optional specifications

The optional specifications describe additional features for the device (optional features). The number of positions depends on the number of features available. The features have a 2-digit structure to aid identification (e.g. JA). The first digit (ID) stands for the feature group and consists of a number or a letter (e.g. J = Test, Certificate). The second digit constitutes the value that stands for the feature within the group (e.g. A = 3.1 material (wetted parts), inspection certificate).

More detailed information about the device is provided in the following tables. These tables describe the individual positions and IDs in the extended order code which are relevant to hazardous locations.

### Extended order code: Deltabar



The following specifications reproduce an extract from the product structure and are used to assign:

- This documentation to the device (using the extended order code on the nameplate).
- The device options cited in the document.

### Device type

FMD71, FMD72

### Basic specifications

Position 1, 2 (Approval)		
Selected option		Description
FMD71	NA	NEPSI Ex ia IIC T6...T4 Ga/Gb NEPSI Ex ia IIC T6...T3 Ga/Gb
FMD72	NA	NEPSI Ex ia IIC T6...T4 Ga/Gb

Position 5 (Housing Transmitter)		
Selected option		Description
FMD7x	A	Aluminium T14
	B	Stainless steel T14
	C	Stainless steel T17, hygiene

### *Optional specifications*

No options specific to hazardous locations are available.

#### **Safety instructions: General**

- Comply with the installation and safety instructions in the Operating Instructions.
- Staff must meet the following conditions for mounting, electrical installation, commissioning and maintenance of the device:
  - Be suitably qualified for their role and the tasks they perform
  - Be trained in explosion protection
  - Be familiar with national regulations
- For installation, use and maintenance of the device, users must also observe the requirements stated in the Operating Instructions and the standards:
  - GB 50257-2014: "Code for construction and acceptance of electric device for explosion atmospheres and fire hazard electrical equipment installation engineering".
  - GB/T 3836.13-2021: "Explosive atmospheres, Part 13: Equipment repair, overhaul, reclamation and modification".
  - GB/T 3836.15-2017: "Explosive atmospheres, Part 15: Electrical installations design, selection and erection".
  - GB/T 3836.16-2022: "Explosive atmospheres, Part 16: Electrical installations inspection and maintenance".
  - GB/T 3836.18-2017: "Explosive atmospheres, Part 18: Intrinsically safe electrical systems".
- Install the device according to the manufacturer's instructions and national regulations.
- Only use the device in media to which the wetted materials have sufficient durability.

#### **Safety instructions: Specific conditions of use**

- For light metal flanges or flange faces (e.g. titanium, zirconium), avoid sparks caused by impact and friction.
- In the case of process connections made of polymeric material or with polymeric coatings, avoid electrostatic charging of the plastic surfaces.
- In the event of additional or alternative special varnishing on the enclosure or other metal parts:
  - Observe the danger of electrostatic charging and discharge.
  - Do not rub surfaces with a dry cloth.
- The sensors can be installed in the boundary wall between Zone 0 and the less hazardous area Zone 1. In this configuration, the process connection is installed in Zone 0, while the sensor enclosure is installed in Zone 1.

*Cover with plastic viewing window (Basic specification, Position 5 = C)*  
Avoid electrostatic charging.

*Potential Electrostatic Charging Hazard*

Avoid electrostatic charging:

- Of plastic surfaces (e.g. enclosure, sensor element, special varnishing, attached additional plates, ...)
- Of isolated capacities (e.g. isolated metallic plates)

**Safety  
instructions:  
Installation**

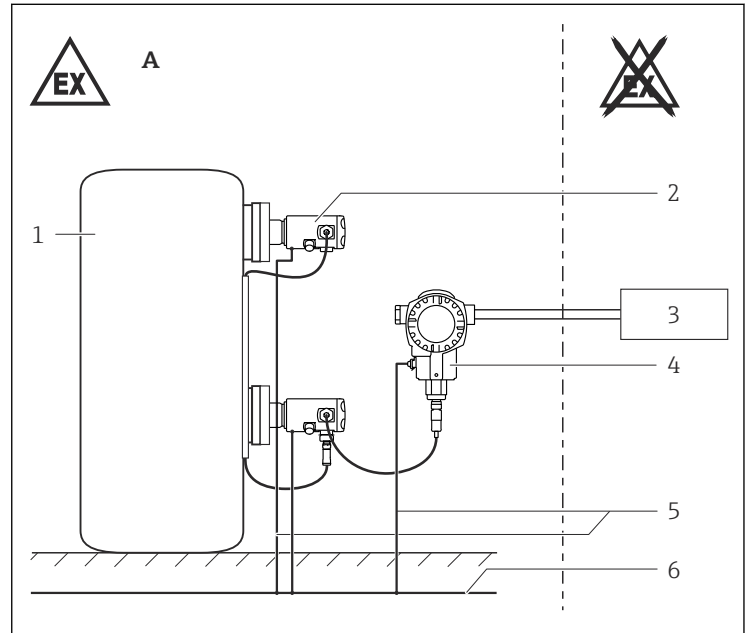

A0032293

 1

- A Zone 1  
 1 Tank; Zone 0  
 2 Sensor module  
 3 Certified associated apparatus  
 4 Transmitter enclosure  
 5 Potential equalization line  
 6 Potential equalization

- After aligning (rotating) the enclosure, retighten the fixing screw.
- Sensor modules may only be connected to the transmitter and interconnected to each other. Any further connections are not allowed.
- Transmitter enclosure and sensor modules must have the same ground potential (e.g. transmitter enclosure and sensor modules all mounted to the same metal structure).  
If potential equalisation can not be achieved by the installation, the devices must be interconnected with a suitable bonding conductor using the external ground connections.

### Intrinsic safety

- The intrinsically safe input power circuit of the device is isolated from ground. The dielectric strength is at least  $500 V_{\text{rms}}$ .
- When the device is connected to an intrinsically safe circuit Ex ib, the type of protection changes to Ex ib. Do not operate intrinsically safe circuits Ex ib in Zone 0.

### Overvoltage protection

Versions with optional terminal block with integrated overvoltage protection: Isolation voltage greater than  $290 V_{\text{rms}}/420 V_{\text{DC}}$  between terminal connection and potentially grounded metal parts.

### Safety instructions: Zone 0

- In the event of potentially explosive vapor/air mixtures, only operate the device under atmospheric conditions.
  - Temperature:  $-20$  to  $+60$  °C
  - Pressure: 80 to 110 kPa (0.8 to 1.1 bar)
  - Air with normal oxygen content, usually 21 % (V/V)
- If no potentially explosive mixtures are present, or if additional protective measures have been taken, the device may also be operated under non-atmospheric conditions in accordance with the manufacturer's specifications.
- Associated devices with galvanic isolation between the intrinsically safe and non-intrinsically safe circuits are preferred.

#### *Device type FMD71*

For installations which require overvoltage protection to comply with national regulations or standards, install the device using overvoltage protection (e.g. HAW56x from Endress+Hauser).



## Temperature tables

### Device type FMD71

#### Compact version

Temperature class	Process temperature $T_p$ (process)	Ambient temperature $T_a$ (ambient): enclosure
T6	$\leq 80\text{ }^\circ\text{C}$	$-40\text{ }^\circ\text{C} \leq T_a \leq +40\text{ }^\circ\text{C}$
T4	$\leq 125\text{ }^\circ\text{C}$	$-40\text{ }^\circ\text{C} \leq T_a \leq +70\text{ }^\circ\text{C}$



The process temperatures refer to the temperature at the separation membrane.

#### High-temperature version

Temperature class	Process temperature $T_p$ (process)	Ambient temperature $T_a$ (ambient): enclosure
T6	$\leq 80\text{ }^\circ\text{C}$	$-40\text{ }^\circ\text{C} \leq T_a \leq +40\text{ }^\circ\text{C}$
T4	$\leq 135\text{ }^\circ\text{C}$	$-40\text{ }^\circ\text{C} \leq T_a \leq +70\text{ }^\circ\text{C}$
T3	$\leq 150\text{ }^\circ\text{C}$	$-40\text{ }^\circ\text{C} \leq T_a \leq +70\text{ }^\circ\text{C}$



The process temperatures refer to the temperature at the separation membrane.

### Device type FMD72

Temperature class	Process temperature $T_p$ (process)	Ambient temperature $T_a$ (ambient): enclosure
T6	$\leq 80\text{ }^\circ\text{C}$	$-40\text{ }^\circ\text{C} \leq T_a \leq +40\text{ }^\circ\text{C}$
T4	$\leq 125\text{ }^\circ\text{C}$	$-40\text{ }^\circ\text{C} \leq T_a \leq +70\text{ }^\circ\text{C}$



- The process temperatures refer to the temperature at the separation membrane.
- Higher temperatures are permitted depending on the type of diaphragm seal.
- Do not exceed the max. ambient temperature at the enclosure.

## Connection data

Electrical data
$U_i \leq 30\text{ V}_{DC}$ $I_i \leq 300\text{ mA}$ $P_i \leq 1\text{ W}$ $C_i \leq 11.8\text{ nF}$ $L_i = 0$







71637766

[www.addresses.endress.com](http://www.addresses.endress.com)

---