

Clean water is life!

Continuous disinfection measurement with the digital Memosens sensors for chlorine dioxide, free chlorine, total chlorine, free bromine and ozone



Memosens disinfection portfolio

Safe water is life! That's why our drinking water must be disinfected to protect it from bacteria, viruses and other harmful organisms. The same applies to our environment and water in industrial processes. Different disinfectants are used: chlorine, chlorine dioxide, bromine and ozone inactivate bacteria by breaking down or penetrating their cell walls and preventing metabolic processes in the cells.

Disinfection processes are set to become ever more important in future, particularly in view of trends such as water scarcity and climate change. After all, clean water is and will remain a foundation for a healthy life. The ability to guarantee this is what many of our partners and customers are striving for. Our comprehensive disinfection portfolio is here to help you do just that!



Benefits for you at a glance

The Memosens sensors feature a variety of benefits and functions for monitoring and optimizing your disinfection processes - and make your life easier along the way.

Continuous and precise measurement

Using amperometric sensors, monitor your process in real time without the interruptions associated with the colorimetric measurement. Thanks to rapid acquisition of measured values, dosing of disinfectants can take place more precisely. This ensures not only high process reliability, but also cost efficiency.



Efficient process control

Many amperometric sensors are slow to respond after lengthy periods without chlorine. Thanks to the fast response time of our sensors, however, you can react swiftly to changes and thereby ensure efficient process control.

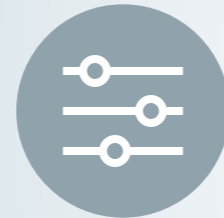

Quick commissioning and high plant availability

Introduce the precalibrated sensor to the process with total ease by plug & play. After connection, the sensors need only a short polarization time before they show a stable measured value and the plant is soon fully functional.



Low and predictive maintenance

The new generation of Memosens sensors stores more data on calibration and operating hours, e.g. the electrolyte counter. That's why the maintenance strategy can be developed and optimized for the specific application. In addition, robust components – such as the convex membrane made from dirt-repellent material – mean that the sensors are easy to maintain.



Reduced operating and maintenance costs

Benefit from reduced costs of the measuring point: By comparison with colorimetric measuring systems, you don't need any reagents and there is no associated disposal. Costs are also reduced by the tendency for less maintenance effort and fewer measurement errors across a wider measuring range.

Combination with other parameters

By connecting to a Liquiline multiparameter transmitter, you can combine your disinfection measurement with other relevant parameters of liquid analysis.



Industry focus: Applications

How many liquids have you encountered today already? These might include the milk in your breakfast, the water in your shower or the drops in your medical cabinet. All of these liquids have one thing in common. In all likelihood, they have been subjected to disinfection measurements – either because the water itself was disinfected or because these liquids flow through pipes or are stored in bottles that were disinfected. After all, disinfection plays a key role in many industrial production processes that are relevant to everyday life.





Water

The objective of drinking water treatment and the distribution system is to deliver water of outstanding quality safely to consumers. The benefits of having a strategy separated into process disinfection and distribution disinfection are explained in the sections that follow. Our sensors can support you in both processes.

Salty seawater is an exceptional case in that it contains a higher amount of bromide salts than normal water and entails special chemical reactions during seawater disinfection. For this reason, desalination plants measure the bromine concentration.



Drinking water treatment

To transport drinking water from one end of the distribution system to the other and to the actual point of use, a small amount of free chlorine or chlorine dioxide is added to the water at the outlet of the waterworks. This helps to prevent the already treated water from being recontaminated at any point in transit. Disinfection here is often at trace level.

Inside the treatment process in the waterworks, it's an entirely different story: Here, ozone is often used because it is highly reactive. It oxidizes everything nearby. This makes ozone suitable for disinfecting the water, but not for providing protection in the distribution system.

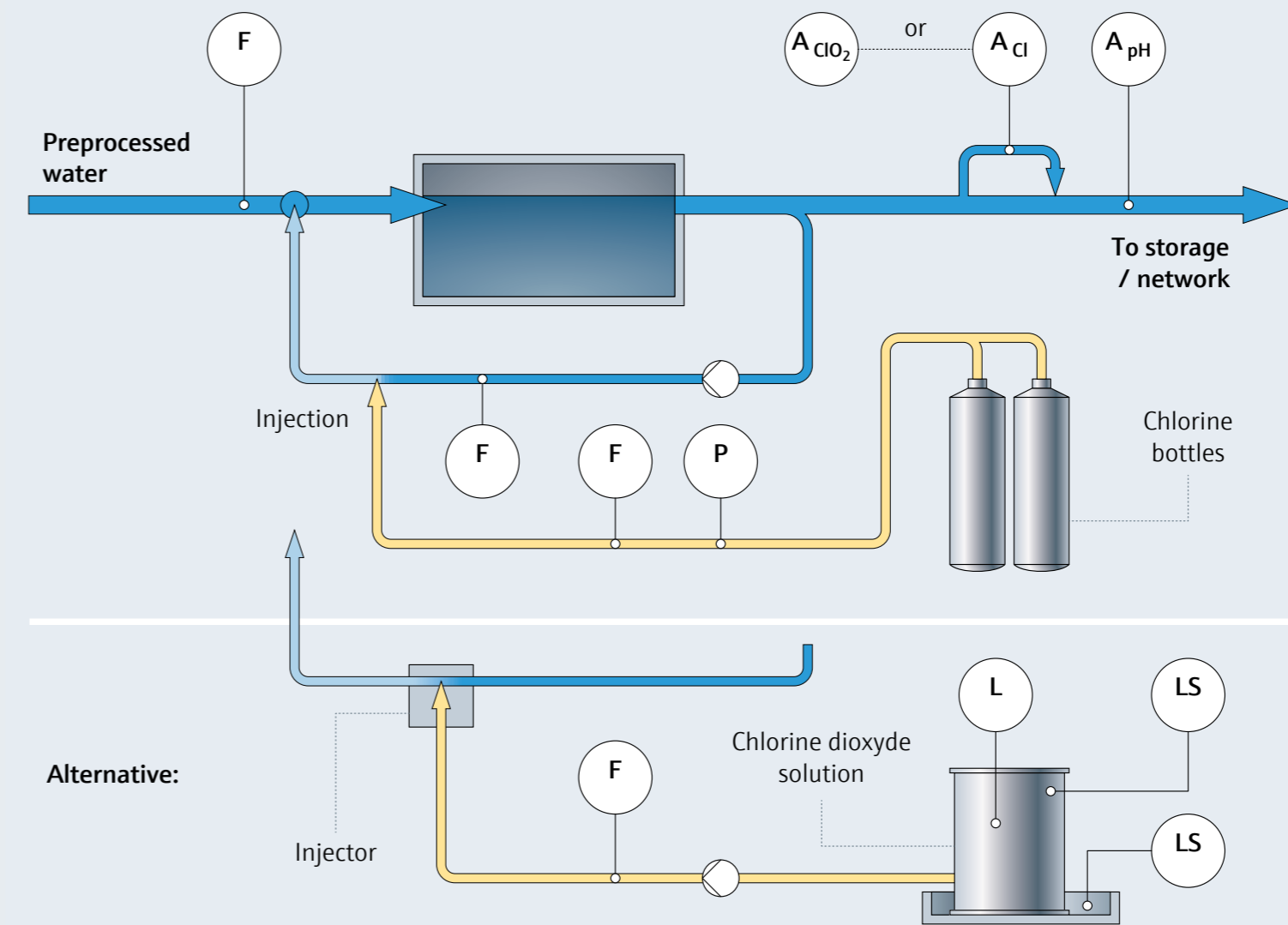

Your challenge

Measuring point: Drinking water plant

Measurement temperature: Up to 55 °C

Process pressure: Max. 1 bar

Our solution

As underdosing and overdosing of disinfectant can be harmful to human beings and cause high costs, compliance with limit values and regulations in the drinking water industry plays a particularly important role. The sensors Memosens CCS50E for chlorine dioxide and Memosens CCS51E for free chlorine are especially suitable in this regard. A crucial factor that must be taken into consideration in the measurement of free chlorine is the pH relationship. Our pH sensors, such as Memosens CPS31E, enable the correct calculation of the chlorine value.



Seawater desalination

In many arid regions of the world, seawater is used for drinking water reclamation. Near the coast, it is put to use as process and cooling water in various industrial applications. To desalinate this water, it should be disinfected beforehand. The aim is to minimize the biological activity of the water as far as possible and, in doing so, maximize the operating time of the downstream filters and the desalination plant.

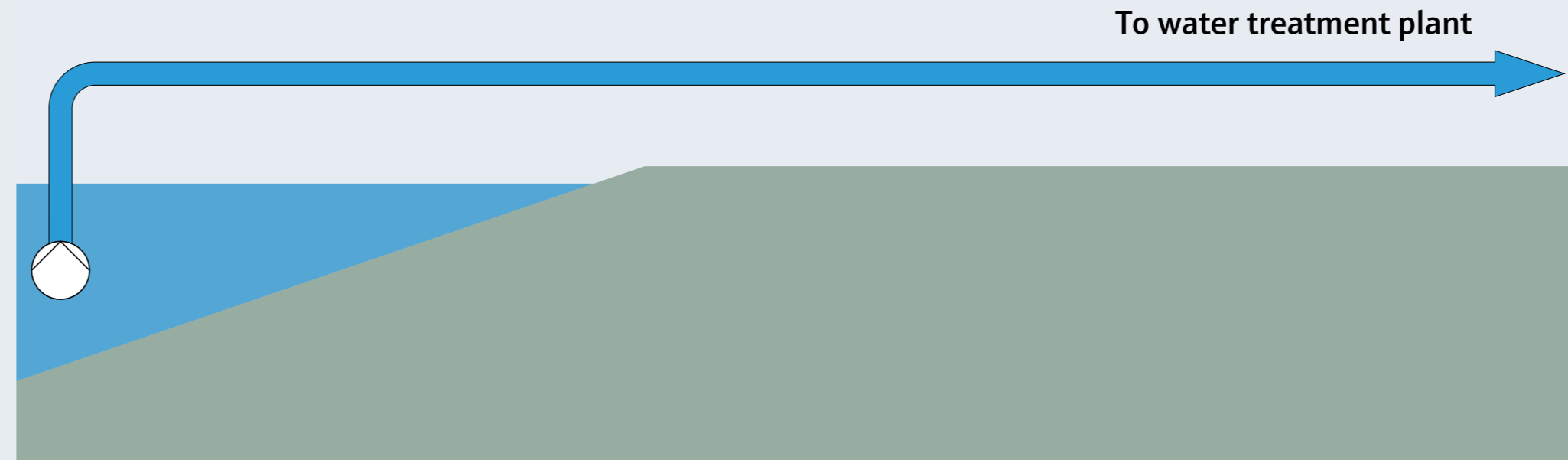

Your challenge

Measuring point: Seawater applications

Measurement temperature: Up to 55 °C

Process pressure: Max. 1 bar

Our solution

Seawater generally contains a higher concentration of bromine than potable water. If hypochlorous acid is added, a hypobromous acid forms. This component has a strong disinfecting effect. Therefore, a bromine measurement is required in order to monitor your process correctly. Suitable for this task is the precise Memosens CCS55E sensor for measuring free bromine. A pH compensation by use of a pH sensor makes it possible to calculate the concentration of free bromine correctly.

Wastewater

At the end of wastewater treatment, the effluent is usually introduced into natural watercourses. In warm weather, the watercourses could be carrying very little water and, under certain circumstances, this water could consist mainly of the outflow from wastewater treatment plants – and this calls for disinfection.

In industry, too, the treatment and reuse of wastewater in secondary processes can be efficient because less fresh water is needed and the costs of wastewater disposal are reduced. If this is not possible, discharging it into the sewerage system or a body of water is the only option.

In both cases, analyzing disinfection parameters improves the safety of processes and enables compliance with limit values.



Wastewater treatment plants

To enable the safe return of the outflowing water into the natural water cycle, water laws may require supporting evidence of a value based on total chlorine or free chlorine. While the exact treatment requirements are dependent on the type of wastewater and the purpose of reuse, disinfection and therefore disinfection measurements play a key role in every treatment method. Global developments, such as

climate change and population growth, are reasons why water is becoming an increasingly scarce commodity. In wastewater reuse, e.g. for agricultural irrigation, there lies a special opportunity to meet this challenge.

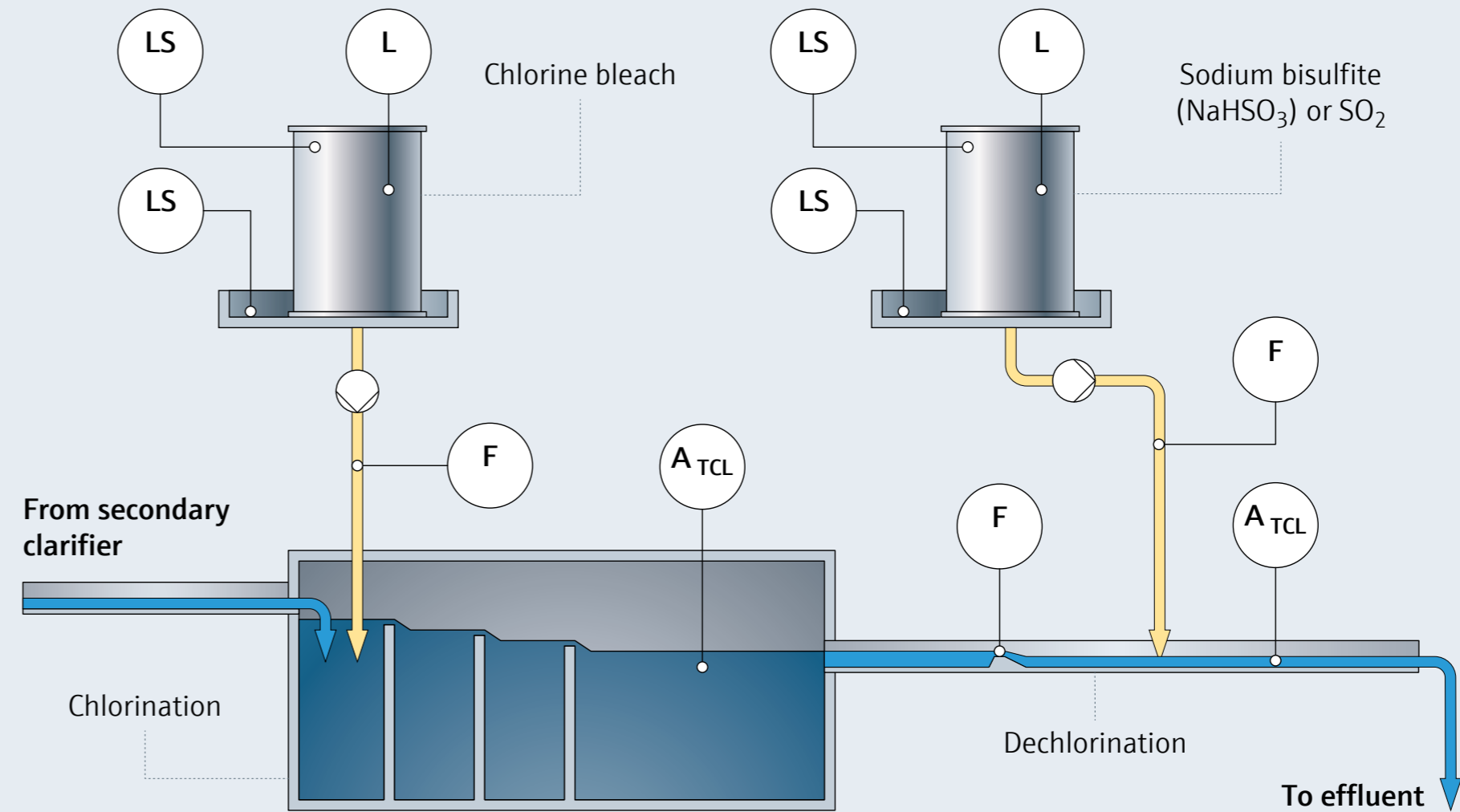

Your challenge

Measuring point: Wastewater treatment

Measurement temperature: Up to 55 °C

Process pressure: Max. 1 bar

Our solution

The outflowing water from wastewater treatment plants typically contains low concentrations of ammonium. In chlorination with free chlorine, this ammonium leads to the formation of chloramines. Chloramines similarly have a disinfecting quality, but this is considerably reduced by comparison with free chlorine. They can be measured using Memosens CCS53E for total chlorine, a sensor that is sensitive to almost all oxidizing components.

Depending on legislation, however, it may also be necessary to determine a value based on free chlorine, which can be measured using the Memosens CCS51E sensor. In this process, free chlorine is added to the medium until all of the chloramines have been re-oxidized and converted.

Utilities

Utilities, such as electricity, water and gas or steam, compressed air and heat, are essential for production industries. They make it possible for the actual core processes to run in the first place. In combination with these utilities, disinfection applications have a role to play, e.g. in cooling. In cooling towers, disinfection is used to prevent the formation of pathogens and biofilms. This protects not only the plants themselves, but also the environment when water vapor is discharged into the surrounding area.



Cooling applications

Cooling applications are present in all industries, e.g. in energy generation. The cooling medium is often water. On the one hand, the aim of disinfection processes here is to avoid the formation of a superficial biofilm and thereby maximize cooling power. Another goal – in food production, for example – is to prevent the ingress of coolant into the production circuit. Or, conversely, to avoid proteins passing from the product side to the cooler side, where it could result in considerable foaming.

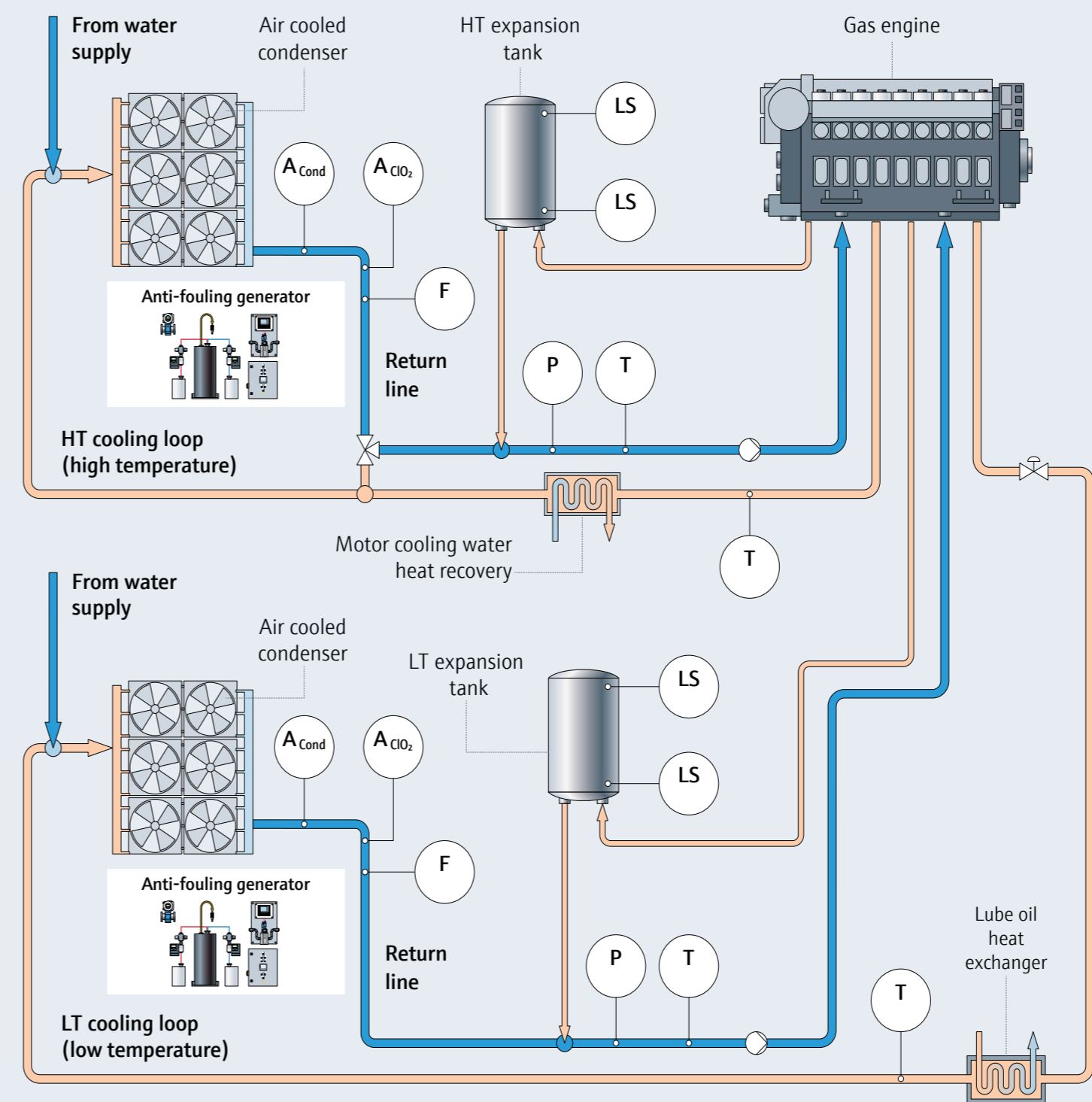

Your challenge

Measuring point: Cooling circuit

Measurement temperature: Up to 55 °C

Process pressure: Max. 1 bar

Our solution

A disinfecting agent is typically added to the coolant in order to avoid bacterial lawns from forming in the cooler lines. Chlorine dioxide has proven effective in this process because it works across a wide pH range and retains its effectiveness even with the addition of pH-increasing corrosion inhibitors. The Memosens CCS50E sensor makes it possible to measure this parameter.



Food and beverages

Disinfection is used in various ways in the food and beverage industry. The disinfection of foodstuffs, such as ready-to-eat salads, is one example. Local and regional legislation determines which substance can be used in each application and in which concentration. This is why the use of disinfecting agents differs from region to region.

In processes designed to ensure hygienic batching, such as bottle and can cleaning, chlorine dioxide is particularly suitable because, unlike chlorine, it does not form harmful compounds and is easy to wash out. Further applications can be found in aquaculture systems (e.g. to protect stocks in fish and shrimp farming), reverse osmosis plants and beverage manufacturing.



Reverse osmosis in beverage manufacturing

Even though the raw water can differ from one production location to another, a particular drink is always supposed to taste the same. For this reason, raw water treatment in soft drink manufacturing is a multi-step process. First, the water is fed into a reverse osmosis plant to reduce the concentration of dissolved substances. The water passes through the membrane, while other constituents are retained. If the product water is disinfected before reverse osmosis, it must be ensured that the chlorine is completely removed from the water by, for example,

activated carbon filtration in order to protect the membranes. Damaged membranes could subsequently lead to massive costs. In many cases, disinfection of the product water takes place with free chlorine after the reverse osmosis process. The product water is then freed of all chlorine traces by filtration because it has to be chlorine-free before the drink syrup is added.

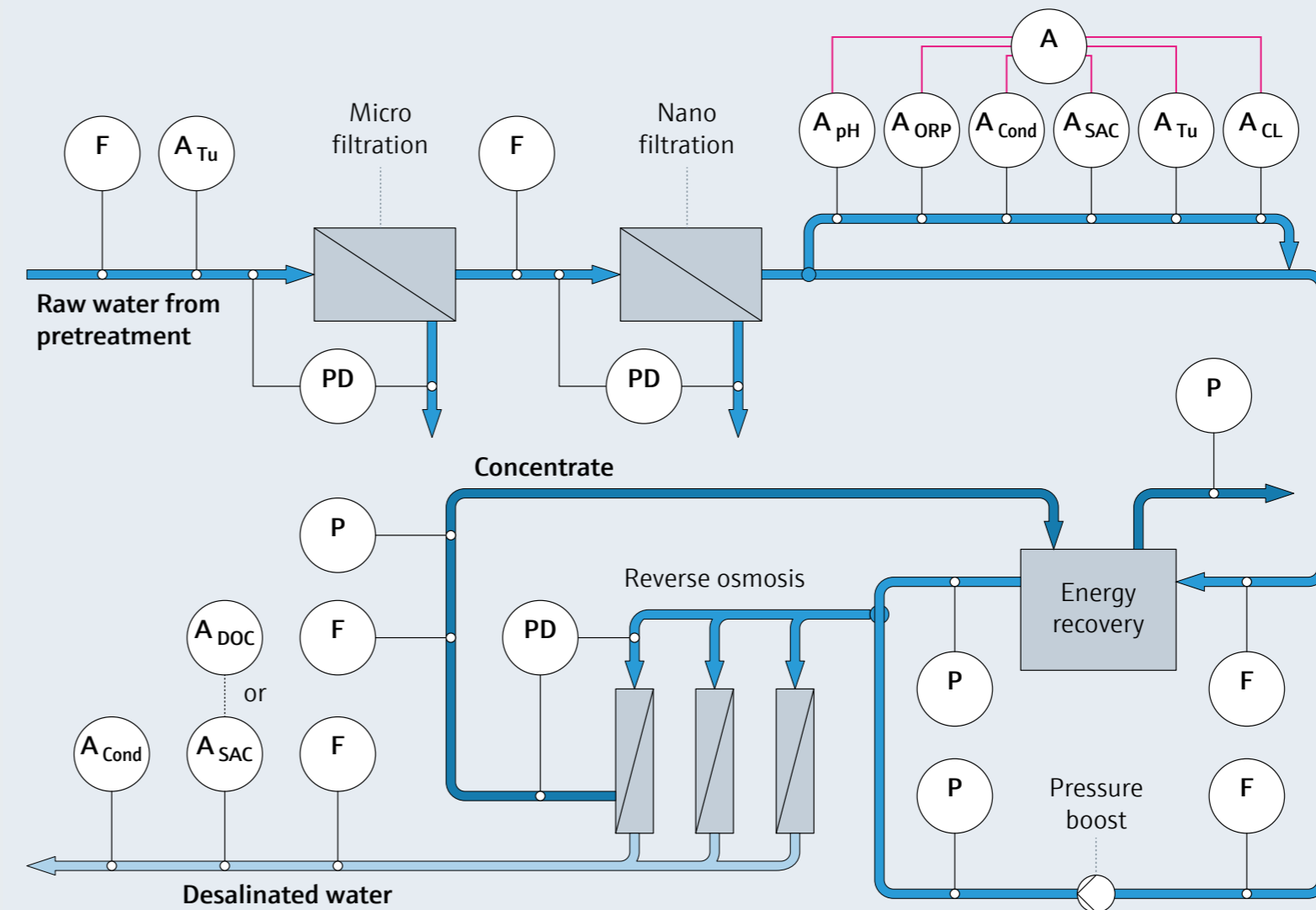

Your challenge
Measuring point: Soft drink manufacturing
Measurement temperature: Up to 55 °C
Process pressure: Max. 1 bar

Our solution
Our sensors help with the monitoring of chlorine removal and the cold cleaning in place process (CIP). The challenge here is the absence of chlorine over lengthy periods. With many amperometric sensors, this leads to a delayed response known as falling asleep. Our chlorine sensors exhibit no delay in their response time even after a long period of inactivity and thereby ensure that no chlorine peaks remain undetected – by comparison with the DPD method. In addition, the sensor regularly “sees” chlorinated water when filtration is bypassed for line cleaning. This acts as a function test and safeguards activation of the sensor.

The amperometric measuring principle

Robust measurement without use of reagents

The Memosens disinfection sensors operate in accordance with the amperometric measuring principle. With this method, an electrochemically generated current is used. Inside the sensor, there are two electrodes in an electrolyte-filled chamber that is separated from the process by a permeable membrane. Disinfectant molecules and individual gases pass through the membrane in line with the partial pressure difference between the medium and the

electrolyte and they are then reduced at the cathode. This generates a current proportional to the amount of converted disinfectant. This is calculated at the transmitter and shown in the familiar units mg/l.

This diagram shows how chlorine dioxide is diffused by the membrane and undergoes reduction at the cathode. The electron gain is proportional to the chlorine concentration.

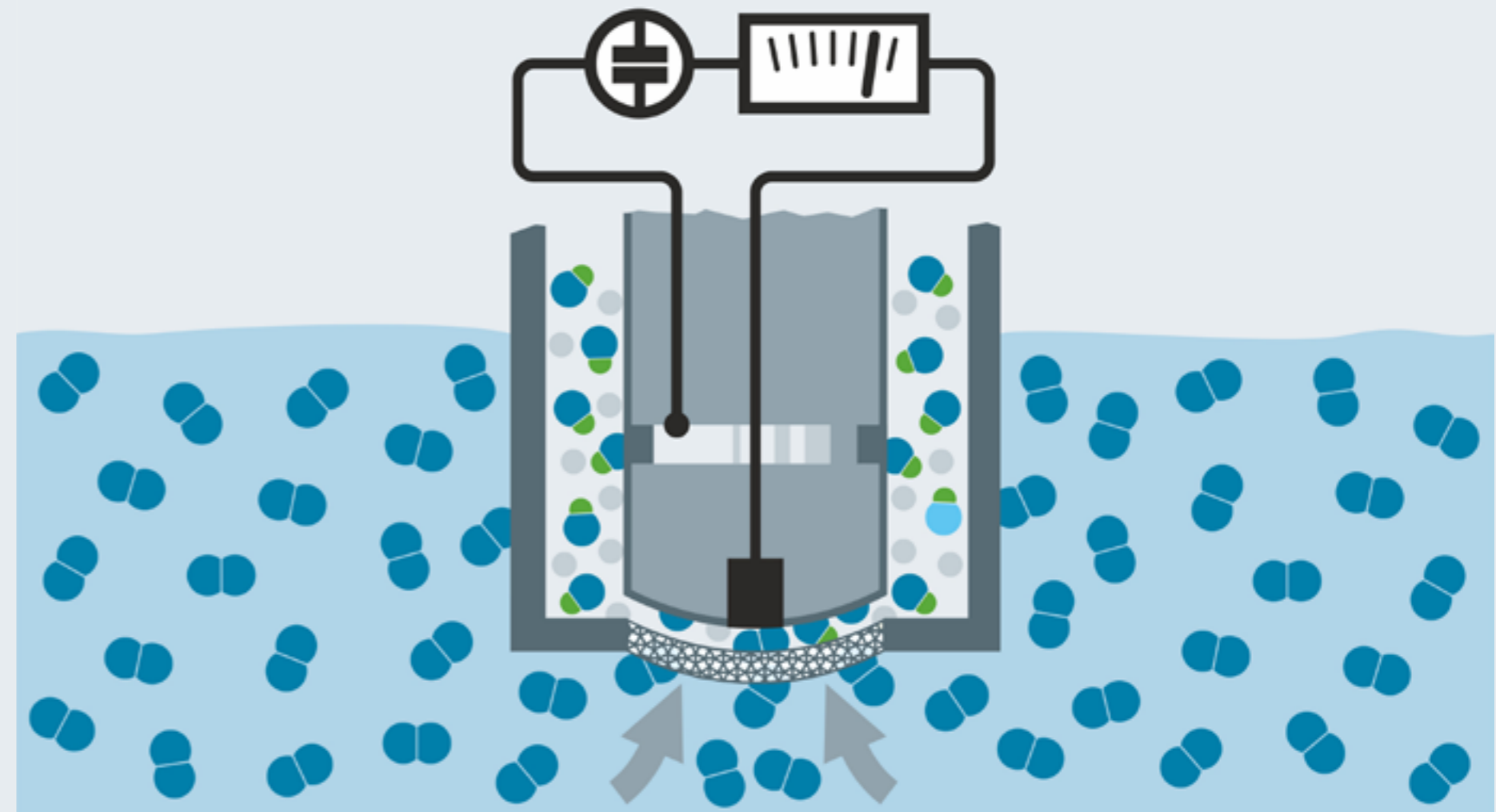

Technical data

Overview

Different disinfection applications require different disinfection sensors. With our broad portfolio, we can find a matching solution whatever your application is.

What sets all sensors apart: Memosens 2.0 technology

- **Easy:** With precalibrated sensors, you save time, minimize downtimes and reduce measurement errors. The pluggable coupling system enables easy and genuine plug & play.
- **Safe:** The digital transmission of measured values provides reliable data in real time. Malfunctions are easy to identify and rectify thanks to digital connectivity - a plus for safety.
- **Connected:** Memosens technology stores numerous types of information. The use of these data opens up new possibilities, such as IIoT services and predictive maintenance.

>

> CCS50E

Memosens CCS50E

Digital chlorine dioxide sensor



Measurement task	Chlorine dioxid
Measuring range	<ul style="list-style-type: none">▪ Trace levels: 0 to 5 mg/l ClO₂▪ Standard: 0 to 20 mg/l ClO₂▪ High concentrations: 0 to 200 mg/l ClO₂
Fields of application	<ul style="list-style-type: none">▪ Cooling water and cooling applications: to prevent the formation of pathogens and biofilms▪ Process water: for example in the food industry to guarantee hygienic and safe packaging and batching▪ Beverage and reverse osmosis plants: to ensure the absence of chlorine dioxide▪ Drinking water: to ensure sufficient disinfection
Process temperature	0 to 55 °C, non-freezing
Process pressure	Max. 1 bar

>

> CCS51E

Memosens CCS51E

Digital sensor for free chlorine



Measurement task

Free chlorine

Measuring range

- Trace levels: 0 to 5 mg/l HOCl
- Standard: 0 to 20 mg/l HOCl
- High concentrations: 0 to 200 mg/l HOCl

Fields of application

- Drinking water: to ensure sufficient disinfection without overdosing
- Utilities: to sense free chlorine and prevent harmful effects
- Process water: for hygienic packaging and batching of for example food and beverages
- Swimming pools: to dose the disinfectant as efficiently as possible

Process temperature

0 to 55 °C, non-freezing

Process pressure

Max. 1 bar

>

> CCS53E

Memosens CCS53E

Digital total chlorine sensor



Measurement task

Total chlorine

Measuring range

- 0 to 5 mg/l TCL
- 0 to 20 mg/l TCL

Fields of application

- Wastewater treatment plants: to monitor wastewater and enable its reuse
- Process water in utilities of all industries: to detect chlorine and prevent its harmful effects (e.g. in cooling towers)
- Food industry: to guarantee hygienic batching and high product quality (e.g. in washing water) and to protect the membranes in reverse osmosis plants
- Drinking water: to ensure sufficient disinfection and simultaneously prevent overdosing
- Swimming pool: to sense impurities

Process temperature

0 to 55 °C, non-freezing

Process pressure

Max. 1 bar

>

> CCS55E

Memosens CCS55E

Digital sensor for free bromine



Measurement task

Free bromine

Measuring range

- Trace levels: 0 - 5 mg/l HOBr
- Standard: 0 - 20 mg/l HOBr
- High concentrations: 0 - 200 mg/l HOBr

Fields of application

- Seawater applications (e.g. desalination plants): to guarantee reliable disinfection and support efficient dosing
- Process and cooling water: where bromine is used as the disinfectant due to its less corrosive nature
- Food industry: for accurate monitoring of water in fish farming
- Swimming and hydrotherapy pools: where bromine is used due to the salt content of the water and as an alternative to chlorine

Process temperature

0 to 55 °C, non-freezing

Process pressure

Max. 1 bar

>

> CCS58E

Memosens CCS58E

Digital ozone sensor

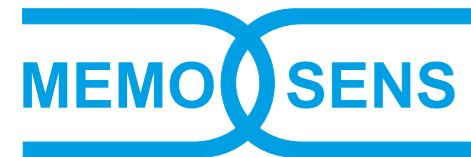

Measurement task

Ozone

Measuring range

■ 0 ... 2 mg/l

Fields of application

- Wastewater: to remove trace amounts, such as pharmaceutical residues, and thereby ensure safe effluent
- Drinking water: to guarantee sufficient disinfection
- Process water: to ensure hygienic batching and disinfect pipes
- Cooling water: to prevent the formation of pathogens and benefit from the low corrosion rate
- Swimming pools: to treat the pool water using the ozone-bromine method

Process temperature

0 to 45 °C, non-freezing

Process pressure

Max. 1 bar

People for Process Automation

Continuous disinfection measurement with the digital sensors Memosens CCS50E for chlorine dioxide, Memosens CCS51E for free chlorine, Memosens CCS53E for total chlorine, Memosens CCS55E for free bromine and Memosens CCS58E for ozone.

Follow us on social media

