

# Operating Instructions

## NAR300 system for high temperature

### temperature

Oil leak detector float sensor





A0023555

## Table of contents

<b>1</b>	<b>Document information</b> .....	<b>4</b>	<b>9</b>	<b>Repair</b> .....	<b>42</b>
1.1	Document function .....	4	9.1	General information on repairs .....	42
1.2	Symbols used .....	4	9.2	Spare parts .....	42
1.3	Documentation .....	6	9.3	Endress+Hauser services .....	42
<b>2</b>	<b>Basic safety instructions</b> .....	<b>7</b>	9.4	Return .....	43
2.1	Requirements for personnel .....	7	9.5	Disposal .....	43
2.2	Designated use .....	7	<b>10</b>	<b>Accessories</b> .....	<b>44</b>
2.3	Workplace safety .....	7	10.1	Float guide .....	44
2.4	Operational safety .....	8	10.2	U-bolt / cable gland (waterproof connection for JPNEx) .....	45
2.5	Product safety .....	8	<b>Index</b> .....	<b>46</b>	
<b>3</b>	<b>Product description</b> .....	<b>9</b>			
3.1	Product design .....	9			
3.2	Technical data .....	9			
3.3	Process conditions .....	11			
3.4	Delivery example by order code .....	12			
3.5	Detection sensitivity .....	14			
3.6	Pit water .....	14			
<b>4</b>	<b>Incoming acceptance and product identification</b> .....	<b>15</b>			
4.1	Incoming acceptance .....	15			
4.2	Product identification .....	15			
4.3	Manufacturer address .....	19			
4.4	Storage and transport .....	19			
<b>5</b>	<b>Installation</b> .....	<b>20</b>			
5.1	NAR300 system dimensions .....	20			
5.2	Installation conditions .....	24			
5.3	Mounting NAR300 system .....	26			
5.4	Adjustment .....	30			
<b>6</b>	<b>Electrical connection</b> .....	<b>31</b>			
6.1	NRR262-4/A/B/C wiring .....	31			
6.2	NRR261-5 wiring .....	33			
6.3	Wiring diagram .....	35			
6.4	Alarm activation principle .....	36			
<b>7</b>	<b>Diagnostics and troubleshooting</b> ...	<b>37</b>			
7.1	Fail-safe (alarm is output when there is no oil leak) .....	37			
7.2	Delayed alarm (alarm is not output when there is an oil leak) .....	37			
7.3	Operation check .....	38			
7.4	Firmware history .....	40			
<b>8</b>	<b>Maintenance</b> .....	<b>41</b>			
8.1	Maintenance work .....	41			
8.2	Endress+Hauser services .....	41			

# 1 Document information

## 1.1 Document function

These Operating Instructions contain all the information that is required in various phases of the life cycle of the device: from product identification, incoming acceptance and storage, to mounting, connection, operation and commissioning through to troubleshooting, maintenance and disposal.

## 1.2 Symbols used

### 1.2.1 Safety symbols



This symbol alerts you to a dangerous situation. Failure to avoid this situation will result in serious or fatal injury.



This symbol alerts you to a dangerous situation. Failure to avoid this situation can result in serious or fatal injury.



This symbol alerts you to a dangerous situation. Failure to avoid this situation can result in minor or medium injury.



This symbol contains information on procedures and other facts which do not result in personal injury.

### 1.2.2 Electrical symbols



Alternating current



Direct current and alternating current



Direct current



Ground connection

A grounded terminal which, as far as the operator is concerned, is grounded via a grounding system.

#### **Protective earth (PE)**

Ground terminals that must be connected to ground prior to establishing any other connections.

The ground terminals are located on the interior and exterior of the device:

- Interior ground terminal: protective earth is connected to the mains supply.
- Exterior ground terminal: device is connected to the plant grounding system.

### 1.2.3 Tool symbols



Phillips head screwdriver



Flat blade screwdriver



Torx screwdriver



Allen key



Open-ended wrench

#### 1.2.4 Symbols for certain types of information and graphics



##### **Permitted**

Procedures, processes or actions that are permitted



##### **Preferred**

Procedures, processes or actions that are preferred

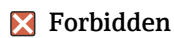

##### **Forbidden**

Procedures, processes or actions that are forbidden



##### **Tip**

Indicates additional information



Reference to documentation



Reference to graphic



Notice or individual step to be observed

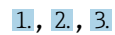

##### **1., 2., 3.**

Series of steps



Result of a step



Visual inspection



Operation via operating tool



Write-protected parameter

**1, 2, 3, ...**

Item numbers

**A, B, C, ...**

Views



##### **Safety instructions**

Observe the safety instructions contained in the associated Operating Instructions



##### **Temperature resistance of the connection cables**

Specifies the minimum value of the temperature resistance of the connection cables

## 1.3 Documentation

The following documents can be found in the Download area of our website ([www.endress.com/downloads](http://www.endress.com/downloads)).

 For an overview of the scope of the associated Technical Documentation, refer to the following:  
*W@M Device Viewer* ([www.endress.com/deviceviewer](http://www.endress.com/deviceviewer)): Enter the serial number from nameplate

### 1.3.1 Technical Information (TI)

#### Planning aid

The document contains all the technical data on the device and provides an overview of the accessories and other products that can be ordered for the device.

### 1.3.2 Brief Operating Instructions (KA)

#### Guide that takes you quickly to the 1st measured value

The Brief Operating Instructions contain all the essential information from incoming acceptance to initial commissioning.

### 1.3.3 Operating Instructions (BA)

The Operating Instructions contain all the information that is required in various phases of the life cycle of the device: from product identification, incoming acceptance and storage, to mounting, connection, operation and commissioning through to troubleshooting, maintenance and disposal.

### 1.3.4 Safety Instructions (XA)

Depending on the approval, the following Safety Instructions (XA) are supplied with the device. They are an integral part of the Operating Instructions.

 The nameplate indicates the Safety Instructions (XA) that are relevant to the device.

## 2 Basic safety instructions

### 2.1 Requirements for personnel

The personnel for installation, commissioning, diagnostics and maintenance must fulfill the following requirements:

- ▶ Be specialists who are trained and have a relevant qualification for this specific function and task.
- ▶ Be authorized by the plant owner-operator.
- ▶ Be familiar with local/national regulations.
- ▶ Before starting work, read and understand the instructions in the Operating Instructions and supplementary documentation as well as the certificates (depending on the application).
- ▶ Follow instructions and comply with basic conditions.

The operating personnel must fulfill the following requirements:

- ▶ Be instructed and authorized according to the requirements of the task by the facility's owner-operator.
- ▶ Follow the instructions in this manual.

### 2.2 Designated use

#### **Application and measured materials**

Depending on the version ordered, the device can also be used with potentially explosive, flammable, poisonous or oxidizing materials.

Devices that are used in hazardous areas have corresponding labels on their nameplates.

To ensure that the device remains in proper condition for the operation time:

- ▶ Only use the device in full compliance with the data on the nameplate and the general conditions listed in the Operating Instructions and supplementary documentation.
- ▶ Check the nameplate to verify if the device can be put to its intended use in hazardous areas.
- ▶ If the device is not operated at an atmospheric temperature, compliance with the relevant basic conditions specified in the relevant device documentation is absolutely essential.
- ▶ Protect the device permanently against corrosion from environmental influences.
- ▶ Observe the limit values in the "Technical Information".

The manufacturer is not liable for damage caused by improper or non-designated use.

### 2.3 Workplace safety

For work on and with the device:

- ▶ Wear the required personal protective equipment according to local/national regulations.

## 2.4 Operational safety

Risk of injury!

- ▶ Operate the device in proper technical conditions and fail-safe conditions only.
- ▶ The plant owner-operator is responsible for interference-free operation of the device.

### Modifications to the device

Unauthorized modifications to the device are not permitted and can lead to unforeseeable dangers:

- ▶ If modifications are nevertheless required, contact your Endress+Hauser Sales Center.

### Repair

To ensure continued operational safety and reliability:

- ▶ Carry out repairs on the device only if they are expressly permitted.
- ▶ Observe local/national regulations pertaining to repair of an electrical device.
- ▶ Use only original spare parts and accessories from Endress+Hauser.

### Ex-area

Observe the following notes to eliminate the risk of danger to persons or the facility when the device is used in Ex-areas (e.g. explosion protection, pressure equipment safety):

- ▶ Check the model nameplate to ensure that the ordered device is explosion proof.
- ▶ Observe the specifications in the separate supplementary documentation attached to these Instructions.

## 2.5 Product safety

This device was designed in accordance with GEP (Good Engineering Practice) to meet state-of-the-art safety requirements, has been tested and left the factory in a condition in which it is safe to operate. It meets the general safety standards and legal requirements.



### 3 Product description

NAR300 system is designed to be installed in a pit within an oil retaining dike, a plant, or a sump pit near a pump yard, where it can provide the ultimate in leak detection function for oils, such as petrochemicals and vegetable oils. A sensor with a conductivity detection function is used to monitor the detection conditions. With a two-stage alarm logic process, it has an extremely low false alarm rate, and this ensures the safety of the tank yard with an accurate yet simple device configuration.

**NOTICE**

**TIIS specifications**

These operating instructions are not intended for products with TIIS specifications.

- ▶ If you are using a product with TIIS specifications, download and refer to BA00403G/JA/23.22-00 or an earlier version from our website ([www.endress.com/downloads](http://www.endress.com/downloads)).

### 3.1 Product design

NAR300 system is configured in combination with mainly the following products.

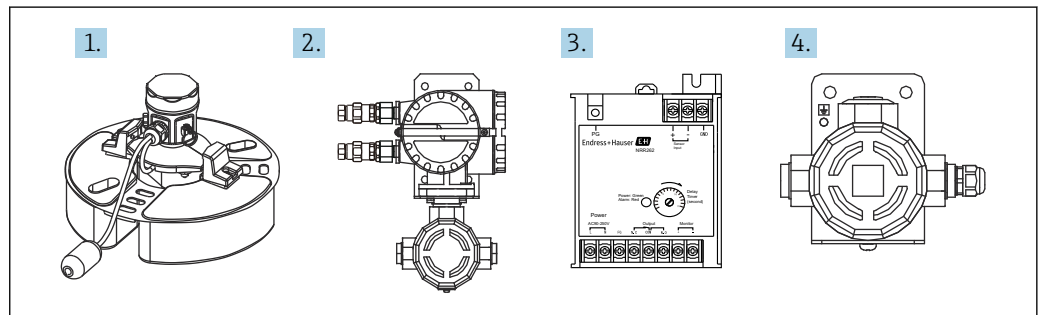

1 NAR300 product design

- 1 Float sensor NAR300
- 2 Ex d [ia] converter NRR261
- 3 Ex [ia] converter NRR262
- 4 Ex [ia] sensor I/F Ex box

### 3.2 Technical data

#### 3.2.1 Float sensor NAR300

Item	Description
Protection class	IP67 (outdoor installation)
Power supply	Supplied by a sensor I/F Ex box or NRR261 (integrated type with NAR300 sensor I/F Ex box)
Wetted material	Float: SUS316L, conductivity sensor: SUS316+PTFE
Detection sensitivity <sup>1)</sup>	Water-filled pit: 10 ± 1 mm (0.04 in) with kerosene at the time of factory shipping
I/O cable	Dedicated shielded cable (PVC) as well as with cable float (Standard 6 m (19.69 ft))
Weight	Approx. 2.5 kg (5.5 lb) (including the 6 m (19.69 ft) dedicated shielded cable (PVC))

1) Set with oil (kerosene: approx. 0.8 in density), lower-layer water (water: approx. 1.0 in density), static level and/or with no surface tension.

### 3.2.2 Ex [ia] sensor I/F Ex box

Item	Description
Protection class	IP67 (outdoor installation)
Power supply	Supplied by NRR261 or NRR262
Cable entry	<ul style="list-style-type: none"> <li>▪ NAR300 (float sensor) side: G1/2, with cable gland</li> <li>▪ NRR261 or NRR262 (converter) side: G1/2, NPT1/2, M20</li> </ul>
Weight	3.2 kg (7.1 lb)
Materials	Housing/cover: Aluminum casting

### 3.2.3 Ex d [ia] converter NRR261

Item	Description
Protection class	IP67 (outdoor installation)
Permissible power-supply voltage range	<ul style="list-style-type: none"> <li>▪ AC power supply type: 90 to 250 V<sub>AC</sub>, 50/60 Hz</li> <li>▪ DC power supply type: 22 to 26 V<sub>DC</sub> (built-in power supply arrester)</li> </ul>
Maximum power consumption	<ul style="list-style-type: none"> <li>▪ AC power supply type: 2 VA</li> <li>▪ DC power supply type: 3 W</li> </ul>
Output	<ul style="list-style-type: none"> <li>▪ Contact output: 1SPDT</li> <li>▪ Maximum contact rating: 250 V<sub>AC</sub>, 1 A, 100 VA or 100 V<sub>DC</sub>: 1 A, 25 W</li> <li>▪ Fail-safe function: Activated when the power supply is turned off and when under frozen conditions (refer to "Alarm output operation table")</li> </ul>
Cable entry	<ul style="list-style-type: none"> <li>▪ G3/4 x2 (Ex d), G1/2 x1 (Ex ia)</li> <li>▪ G1/2 x2 (Ex d), G1/2 x1 (Ex ia)</li> <li>▪ NPT3/4 x2 (Ex d), NPT1/2 x1 (Ex ia)</li> <li>▪ NPT1/2 x2 (Ex d), NPT1/2 x1 (Ex ia)</li> <li>▪ M25 x2 (Ex d), M20 x1 (Ex ia)</li> <li>▪ M20 (Ex d), M20 x1 (Ex ia)</li> <li>▪ JPNEx explosion-proof specifications are equipped with cable gland model SFLU</li> </ul>
Lightning arrester	Built-in (power supply arrester)
Weight	Approx. 10 kg (22 lb)
Materials	Housing/cover: Aluminum casting

### 3.2.4 Ex [ia] converter NRR262

Item	Description
Protection class	IP20 (indoor installation), installed in non-hazardous locations
Permissible power-supply voltage range	<ul style="list-style-type: none"> <li>▪ AC power supply type: 90 to 250 V<sub>AC</sub>, 50/60 Hz</li> <li>▪ DC power supply type: 22 to 26 V<sub>DC</sub> (built-in power supply arrester)</li> </ul>
Maximum power consumption	<ul style="list-style-type: none"> <li>▪ AC power supply type: 2 VA</li> <li>▪ DC power supply type: 3 W</li> </ul>
Output	<ul style="list-style-type: none"> <li>▪ Contact output: 1SPDT</li> <li>▪ Maximum contact rating: 250 V<sub>AC</sub>, 1 A, 100 VA or 100 V<sub>DC</sub>: 1 A, 25 W</li> <li>▪ Fail-safe function: Activated when the power supply is turned off and when under frozen conditions (refer to "Alarm output operation table")</li> </ul>
Lightning arrester	Built-in (power supply arrester)
Weight	Approx. 0.6 kg (1.3 lb)
Materials	Housing: Plastic

### 3.3 Process conditions

#### 3.3.1 Float sensor NAR300 / sensor I/F Ex box

Item	Description
Requirements for substance detection	<ul style="list-style-type: none"> <li>▪ Density is at least 0.7 g/cm<sup>3</sup> but less than 1.0 g/cm<sup>3</sup></li> <li>▪ Floats in water (if the density is 0.9 g/cm<sup>3</sup> or higher, the viscosity must be at least 1 mPa·s. Water=1 mPa·s)</li> <li>▪ Water-insoluble</li> <li>▪ Non-conductive</li> <li>▪ Liquid</li> <li>▪ Low affinity with water (a layer of the substance must be formed on the water)</li> </ul>
Operating temperature	<ul style="list-style-type: none"> <li>▪ Ambient temperature: -20 to 100 °C (-4 to 212 °F)</li> <li>▪ Measured liquid temperature: 0 to 100 °C (32 to 212 °F)</li> </ul>
Requirements for pit water	<ul style="list-style-type: none"> <li>▪ Density is at least 1.0 g/cm<sup>3</sup> but less than 1.13 g/cm<sup>3</sup> (only if the kinematic viscosity is 1 mm<sup>2</sup>/sec)<sup>1)</sup></li> <li>▪ Does not freeze</li> <li>▪ Electric conductivity of 10 µS/cm or higher (up to 100 kΩ · cm)</li> <li>▪ Cannot be used at sea level or in locations that may be penetrated by sea water</li> </ul>
Other conditions	<ul style="list-style-type: none"> <li>▪ Promptly remove any debris that adheres to the sensor unit.</li> <li>▪ Ensure that there is no caked-on mud (dried solids), etc.</li> <li>▪ Avoid installation environments that may cause the float sensor to tilt or change the draft line.</li> <li>▪ Install a breakwater or other similar means to protect against cross-currents and waves.</li> </ul>

1) Sensitivity will vary when the specific gravity of lower-layer water is different from the factory-setting environment, such as when an antifreeze is used.

#### 3.3.2 Connecting cables (connection to Converter NRR261/262 from sensor I/F Ex box)

Item	Description
Connecting cables	Maximum inductance: 2.3 mH, maximum capacitance: 83 nF Example: Use of KPEV-S (instrumentation cable) $C = 65 \text{ nF/Km}$ , $L = 0.65 \text{ mH/km}$ $CW/C = 0.083 \text{ } \mu\text{F} / 65 \text{ nF} = 1.276 \text{ km} \dots 1$ $LW/L = 2.3 \text{ mH} / 0.65 \text{ mH} = 3.538 \text{ km} \dots 2$ Maximum extended cable length: 1.27 km The maximum cable length is either 1 or 2, whichever is shorter (round down instead of rounding off)
Operating temperature	-20 to 60 °C (-4 to 140 °F)

### 3.4 Delivery example by order code

#### Delivery example 1

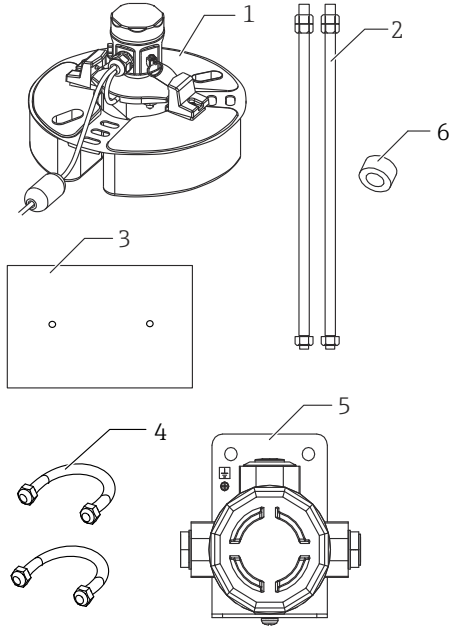
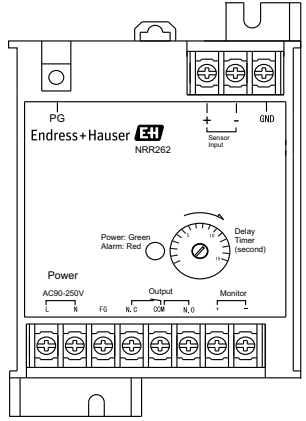
Float sensor order code	Converter order code
NAR300- * 6* * 2 / 3 *	NRR262
 <p>1 Float sensor 2 Float guide (bar) packaged separately 3 Weight (packed at the bottom of the box with the converter) 4 U-bolt 5 Sensor I/F Ex box 6 Check tool (accessory)</p>	

-  The sensor I/F Ex box is included in the order code NAR300-x6xxxx. The intrinsically safe system is used in combination with NRR262.
- A cable gland (water-proof connection) is only included with the sensor I/F Ex box or NRR261 with JPNEEx specifications.

*Delivery example 2*

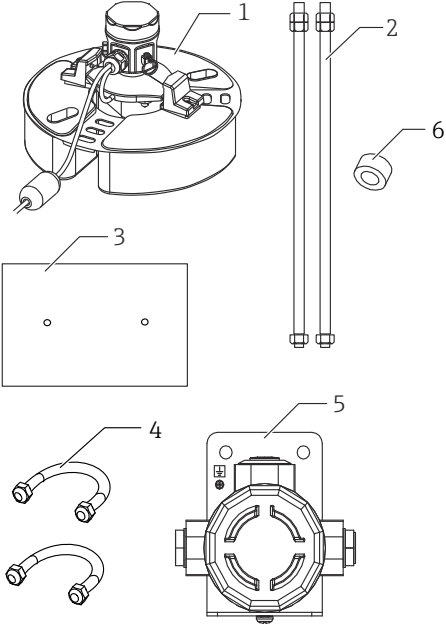
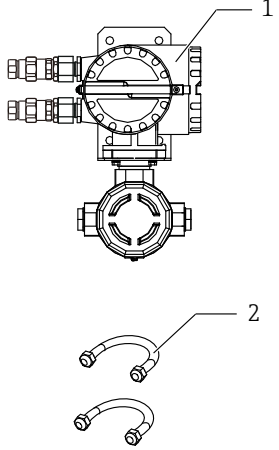
Float sensor order code	Converter order code
NAR300- * 6* * 2 / 3*	NRR261- 5
 <p>1 Float sensor                  2 Float guide (bar) packaged separately                  3 Weight (packed at the bottom of the box with the converter)                  4 U-bolt                  5 Sensor I/F Ex box                  6 Check tool (accessory)</p>	 <p>1 NRR261                  2 U-bolt</p>

- i

 ■ The sensor I/F Ex box is included in the order code NAR300-x6xxxx. The Ex d [ia] system is used in combination with NRR261-5\*\*.
- A cable gland (water-proof connection) is only included with the sensor I/F Ex box or NRR261 with JPNEx specifications.

### 3.5 Detection sensitivity

If the electrode tip is pulled out of the lower-layer water due to increased thickness of the oil layer, water may cling onto the electrode tip like an icicle even if the electrode tip is in oil. In this case, detection sensitivity may increase by 1 to 2 mm (0.04 to 0.08 in). If accurate sensitivity verification is required, apply a small amount of neutral detergent to the electrode tip to improve water release.

### 3.6 Pit water

High-temperature specification is exclusively for applications in which water is constantly present in the pit.

#### 3.6.1 Do not use in sea water

The oil leak detector is not designed for use in sea water. The following problems may occur if it is used in sea water:

- Failed or delayed alarm when overturned by waves
- Delayed alarm caused by generation of a bypass circuit between the conductivity sensor and the float body due to salt coating
- Corrosion of the float sensor caused by sea water

#### 3.6.2 Special pit water

- If the float sensor is used in certain special pit water, such as pit water in which a solvent can enter, the float sensor may become corroded or damaged.
- It cannot measure highly hydrophilic liquids, such as alcohol.

#### 3.6.3 Pit water with high electrical resistance

Use in pit water with high electrical resistance, such as in a steam drain or pure water, may activate the alarm. Ensure that the conductivity of pit water is at least  $10\mu\text{S}/\text{cm}$  (up to  $100\text{k}\Omega \cdot \text{cm}$ ).

Example: Pure water: 1 to  $0.1\mu\text{S}/\text{cm}$  (1 to  $10\text{M}\Omega \cdot \text{cm}$ )

#### 3.6.4 Frozen pit water

If ice forms in the pit, the alarm may be triggered (fail-safe function). Implement anti-freeze measures to prevent freezing.

## 4 Incoming acceptance and product identification

### 4.1 Incoming acceptance

Upon receipt of the goods, check the following:

- Are the order codes on the delivery note and the product label identical?
- Are the goods undamaged?
- Do the nameplate data match the ordering information on the delivery note?
- If required (see nameplate): Are the Safety Instructions (XA) enclosed?

 If one or more of these conditions are not satisfied, contact your Endress+Hauser Sales Center or distributor.

### 4.2 Product identification

The following options are available for identification of the device:

- Nameplate specifications
- Extended order code on the delivery note (including details of the device specification codes)
- Entering the serial number from the nameplate in *W@M Device Viewer* ([www.endress.com/deviceviewer](http://www.endress.com/deviceviewer)) will display all the information about the device.

 Note that the information on a nameplate may be changed without warning when credentials and certificates are updated.

#### 4.2.1 Nameplate specifications

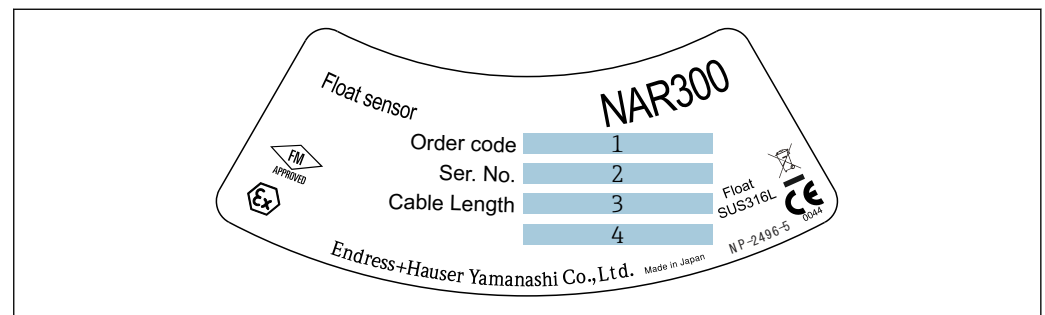

 2 NAR300 model nameplate

- 1 Order code
- 2 Serial number
- 3 Cable length (order code 040)
- 4 Explosion-proof performance (except TIIS specification)

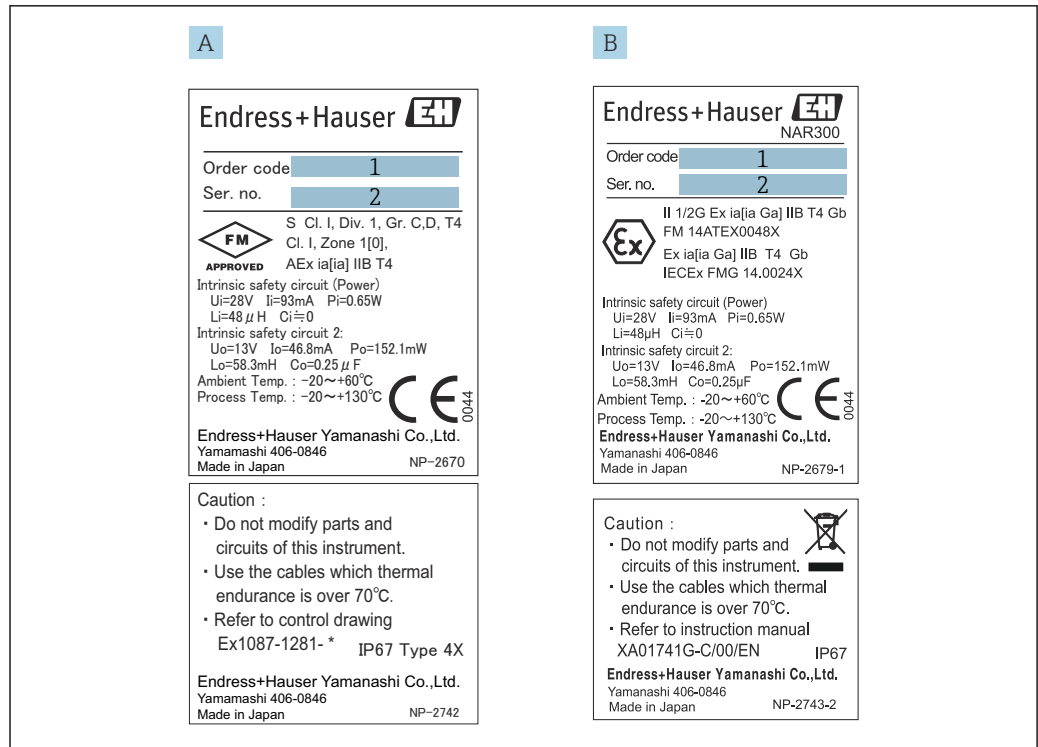

A0039858

3 Nameplate for NAR300

- A NAR300 for FM
- B NAR300 nameplate for ATEX / IECEX
- 1 Order code
- 2 Serial number



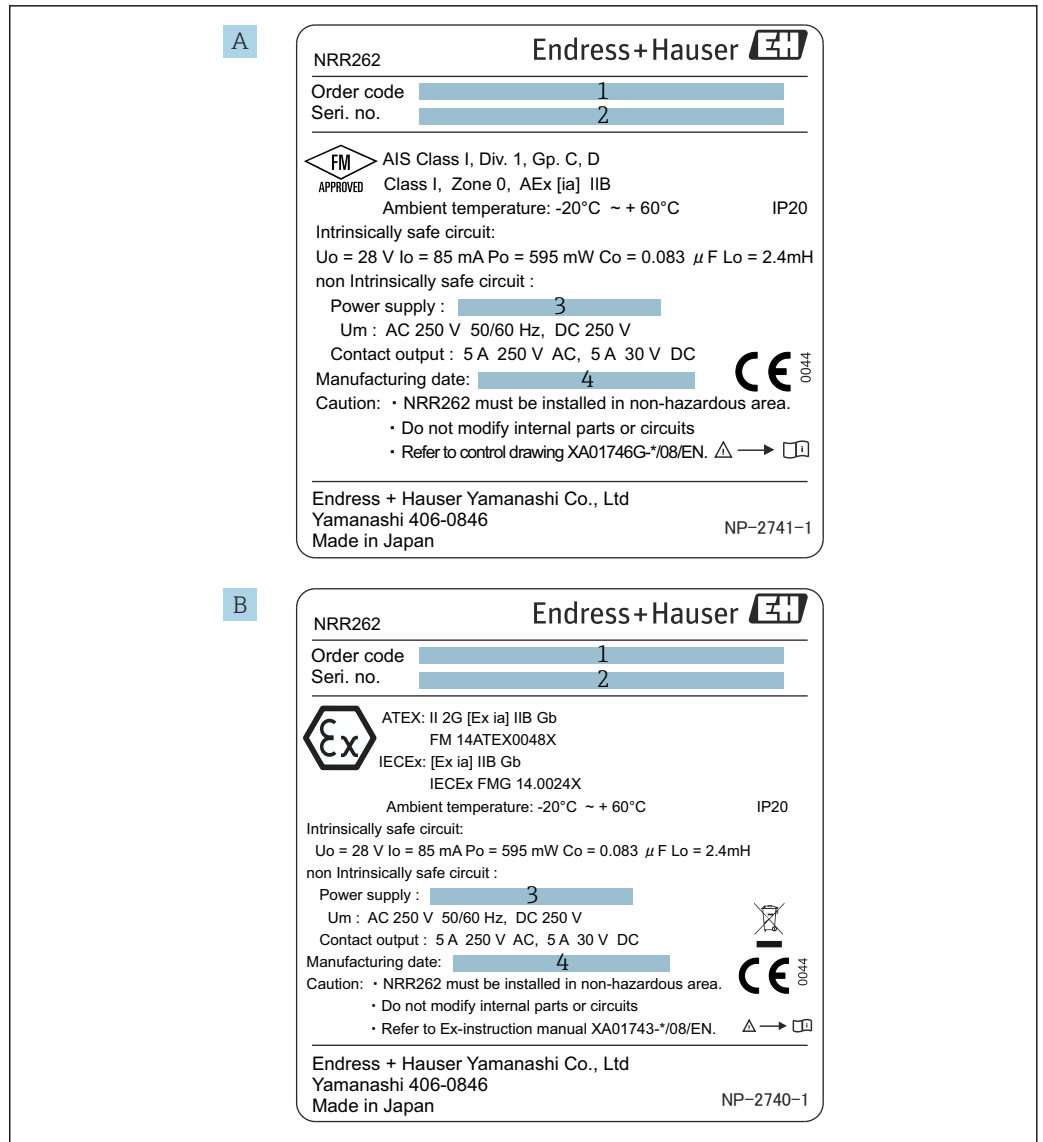

A0039864

4 Nameplate for NRR262

- A NRR262 nameplate for FM
- B NRR262 nameplate for ATEX / IECEx
- 1 Order code
- 2 Serial number
- 3 Power supply voltage
- 4 Manufacturing date

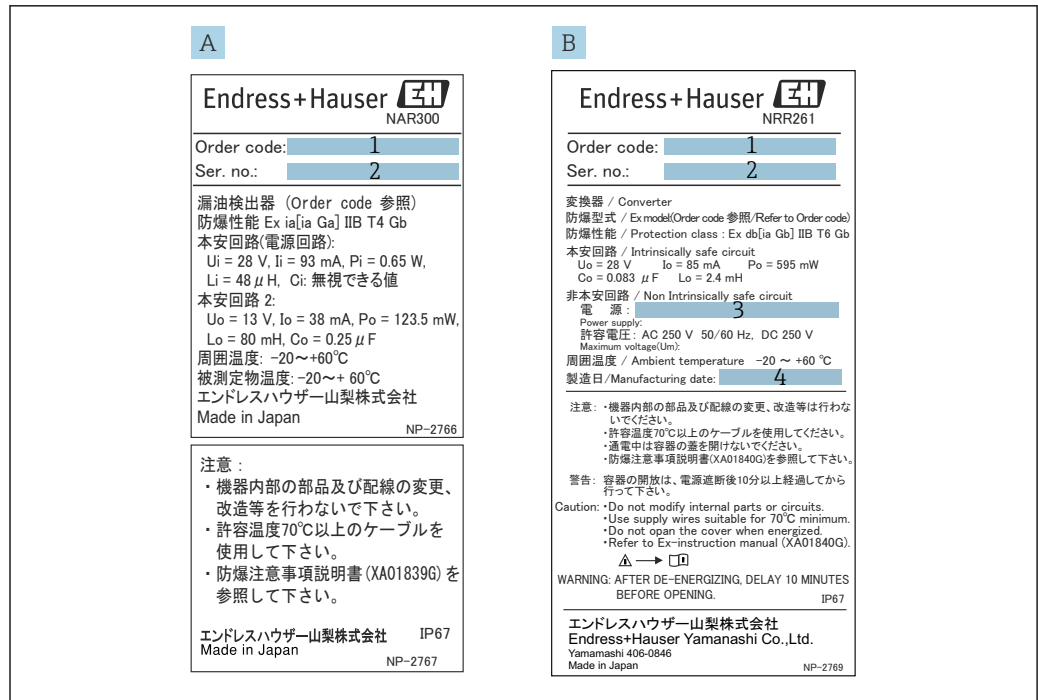

A0039868

5 Nameplate for JPN Ex

- A NAR300 nameplate for JPN Ex
- B NRR261 nameplate for JPN Ex (NAR300 separate type)
- 1 Order code
- 2 Serial number
- 3 Power supply voltage
- 4 Manufacturing date

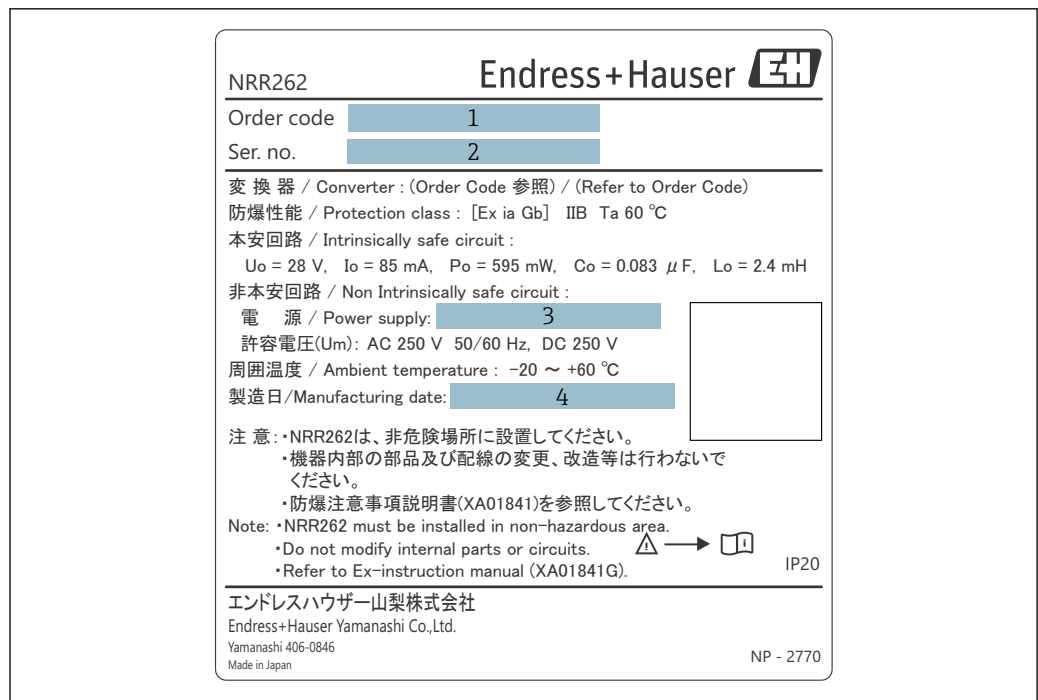

A0039866

6 NRR262 nameplate for JPN Ex

- 1 Order code
- 2 Serial number
- 3 Power supply voltage
- 4 Manufacturing date

## 4.3 Manufacturer address

Endress+Hauser Yamanashi Co., Ltd.  
406-0846  
862-1 Mitsukunugi, Sakaigawa-cho, Fuefuki-shi, Yamanashi

## 4.4 Storage and transport

### 4.4.1 Storage conditions

- Storage temperature: -20 to +60 °C (-4 to 140 °F)
- Store the device in its original packaging.

### 4.4.2 Transport

#### **NOTICE**

**The housing may become damaged or dislodged.**

Risk of injury

- ▶ When transporting the device to the measuring point, either use the device's original packaging or hold by the process connector.
- ▶ Secure a hoisting device (such as a hoisting ring or a lifting eye bolt) to the process connector, not to the housing. Pay attention to the device's center of gravity to prevent unexpected tilting.
- ▶ Comply with the safety precautions and transportation conditions for devices that weigh 18 kg (39.6 lbs) or more (IEC61010).

## 5 Installation

### 5.1 NAR300 system dimensions

#### 5.1.1 Dimensions of NAR300 float sensor

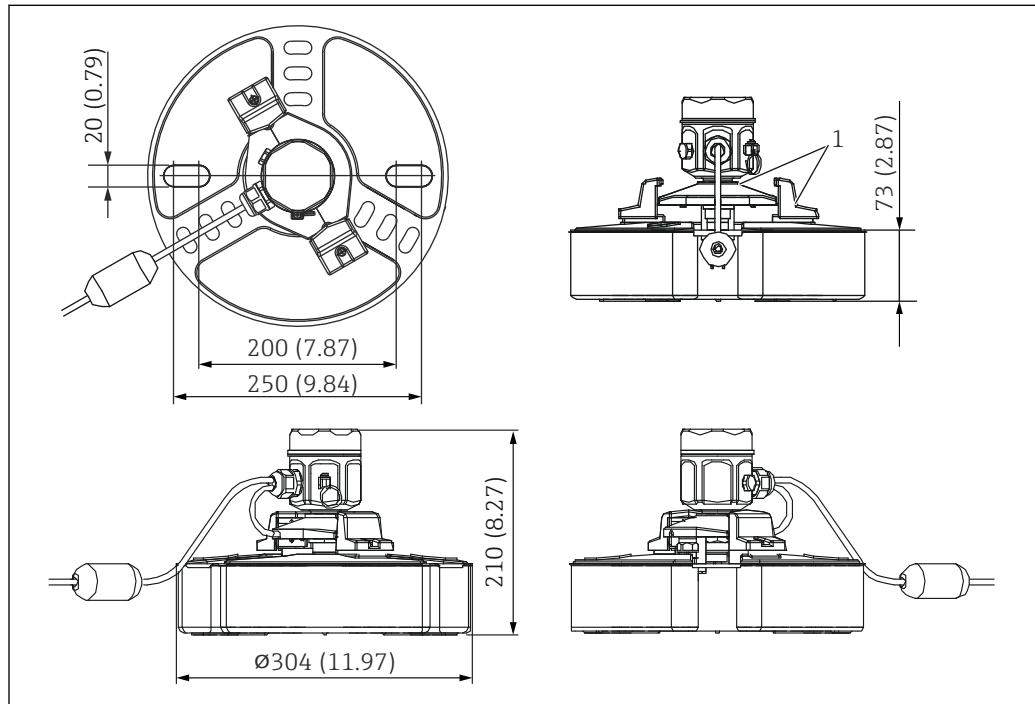

A0039905

7 Float sensor NAR300 dimensions

1 Float sensor cover

### 5.1.2 Dimensions of Ex d [ia] converter NRR261

Only NRR261 with JPN Ex explosion-proof specifications are delivered with a cable gland (external diameter of compatible cables:  $\phi 12$  to 16 mm (0.47 to 1.02 in)).

Use the order code of Ex d [ia] converter NRR261 to specify the conduit connection port.

Ex d [ia] converter NRR261 is usually mounted onto a pipe in the tank yard with a U-bolt (JIS F 3022 B 50 type). It can also be mounted directly onto walls (requires 4- $\phi 12$  mm (0.47 in) holes, M10 securing bolts and nuts (sold separately)).

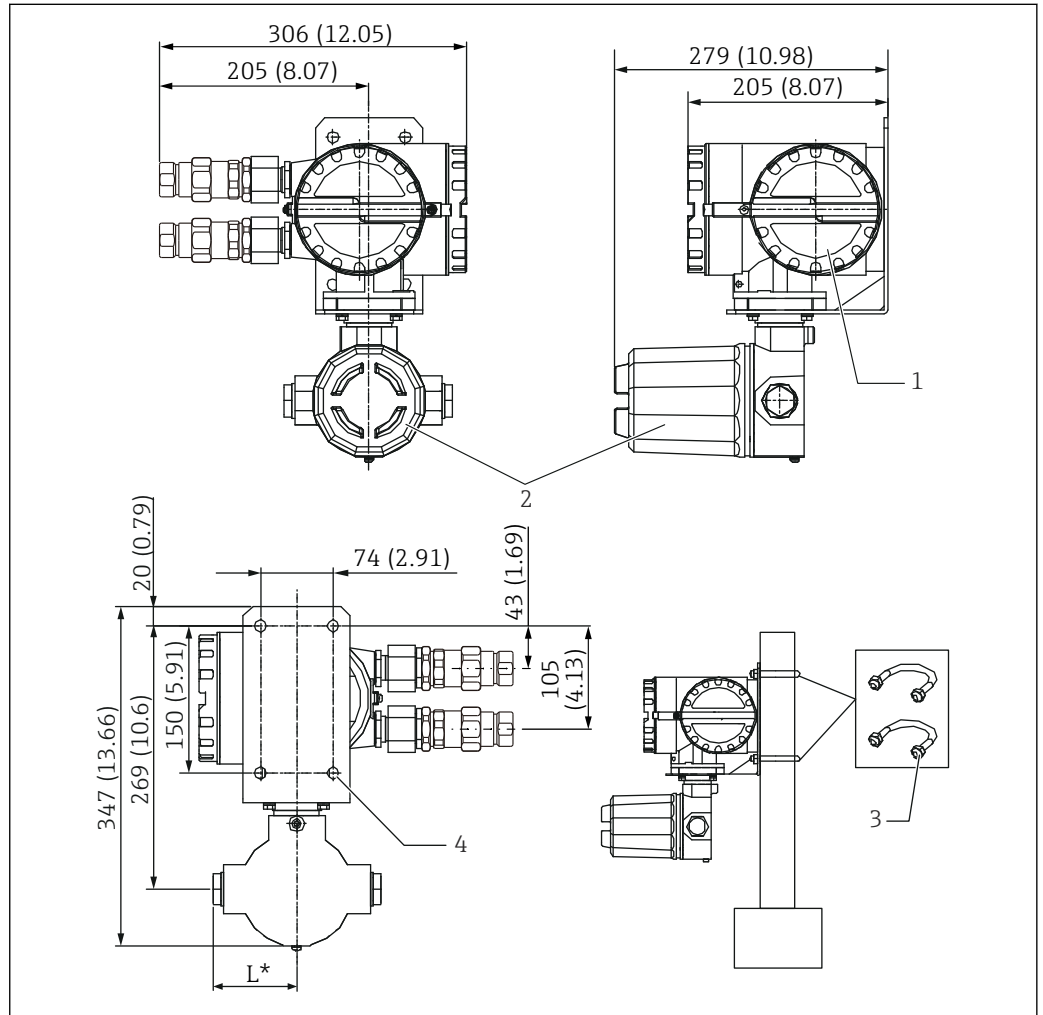

A0039880

8 NRR261 dimensions. Unit of measurement mm (in)

- 1 Ex d side terminal
- 2 Ex [ia] side terminal
- 3 U-bolt (JIS F3022 B50 material: iron (chromate), 2 nuts and 2 flat washers included)
- 4 4- $\phi 12$  hole
- L G1/2: 85 mm (3.35 in), NPT1/2: 97 mm (3.82 in), M20: 107 mm (4.21 in)

### 5.1.3 Dimensions of Ex [ia] converter NRR262

NRR262 is designed for indoor installations, such as in the instrument room, and it can be mounted easily with two M4 screws. It can also be snapped into place with just one touch by using DIN rail EN50022 (sold separately). This rail mounting method is convenient for mounting multiple converters in a row or for when additional converters are scheduled to be installed in the future.

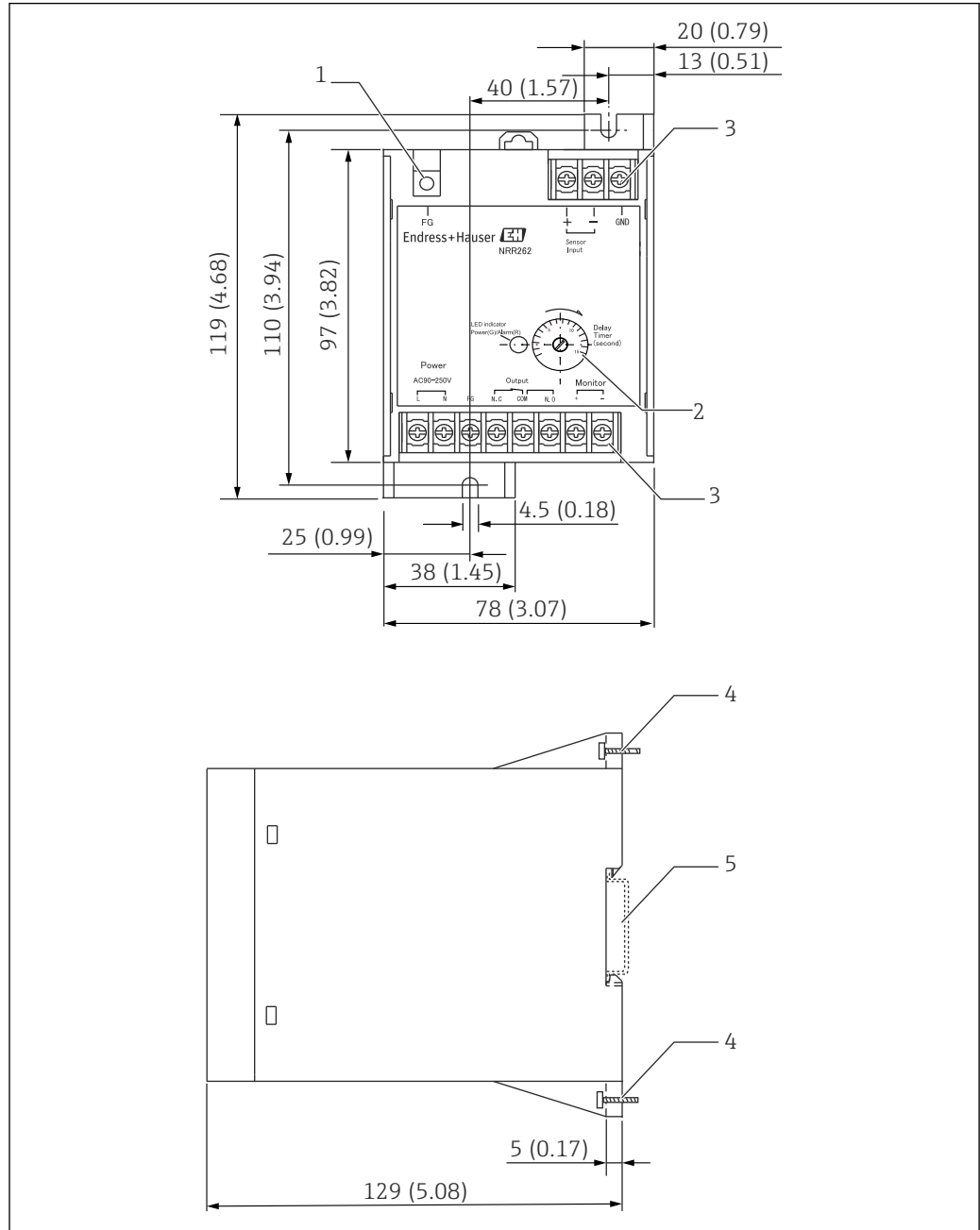

9 NRR262 dimensions. Unit of measurement mm (in)

- 1 Screw (M4) for protective grounding
- 2 Delay trimmer
- 3 Screw (M3)
- 4 Screw (M4)
- 5 DIN rail: Complies with EN50022

### 5.1.4 Dimensions of Ex [ia] sensor I/F Ex box

Ex [ia] sensor I/F Ex box is used in combination with Ex [d] ia converter NRR261 or Ex [ia] converter NRR262 to convert signals from the float sensor into current signals. Ex [ia] sensor I/F Ex box is usually mounted onto a pipe in the tank yard with a U-bolt (JIS F 3022 B 50 type). It can also be mounted directly onto walls (requires 4-φ12 mm (0.47 in) holes, M10 securing bolts and nuts (sold separately)).

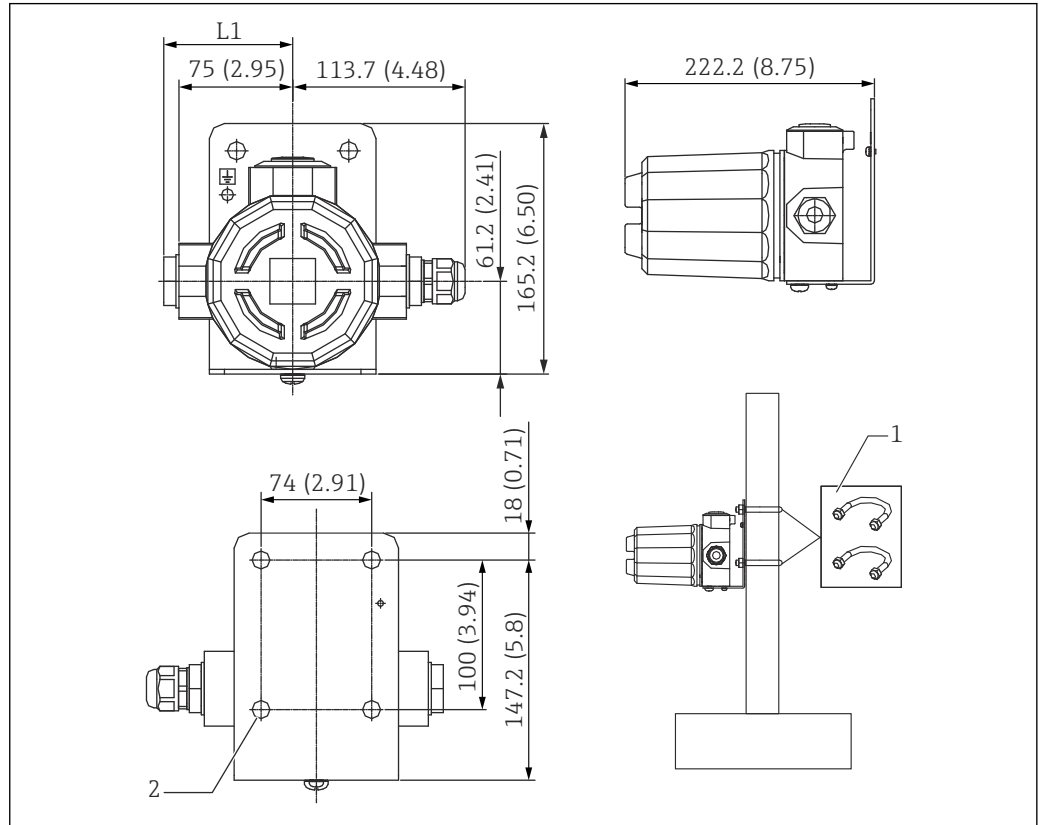

10 Ex [ia] sensor I/F Ex box dimensions. Unit of measurement mm (in)

L1 G1/2 / NPT1/2: 85 mm (3.35 in), M25: 107 mm (4.21 in)

1 U-bolt (JIS F3022 B50 material: iron (chromate), 2 nuts and 2 flat washers included)

2 4-φ12 mm (0.47 in) hole

**i** Use the order code of float sensor NAR300 to specify the conduit connection port.

## 5.2 Installation conditions

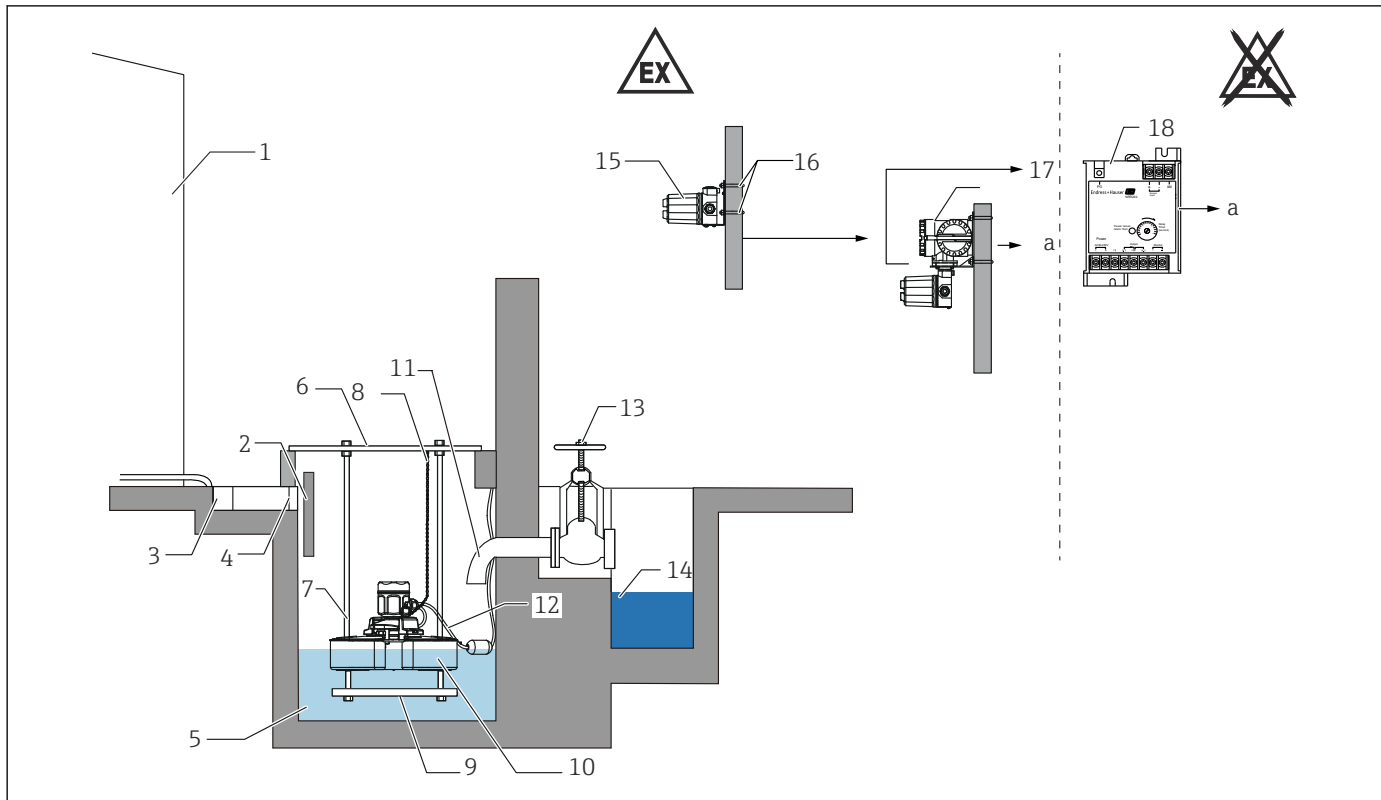

A0039906

### 11 NAR300 + NRR26x

- a Alarm output
- 1 Tank
- 2 Divider
- 3 U-shaped groove
- 4 Screen
- 5 Pit
- 6 Pit cover
- 7 Float guide
- 8 Chain
- 9 Weight
- 10 Float sensor NAR300
- 11 Discharge nozzle (100 mm (3.94 in) or longer)
- 12 Dedicated cable (included with NAR300)
- 13 Valve
- 14 Drainage groove
- 15 Ex [ia] sensor I/F Ex box
- 16 U-bolt (JIS FF3022 B50)
- 17 NRR261 (Ex d [ia] converter)
- 18 NRR262 (Ex [ia] converter)

**i** To ground the barrier, either connect it to the tank or use the shielded wire for remote cable. Refer to "Electrical connection" for more information on using the shielded wire for remote cable.



### 5.2.1 Installation and mounting precautions

1. To prevent snow and debris from entering the pit, installing a waste guard, roof, or other covering is recommended. When snow accumulates on the float sensor, for each 50 g of snow accumulation, the draft line will rise 1 mm (0.04 in), which reduces the float sensor's sensitivity. Mount a covering above the top of the pit inlet to avoid submerging the float sensor housing if the pit water overflows due to heavy rainfall, etc. If water enters the float sensor, it may cause malfunction or failure.
2. If the float sensor becomes off-balanced (tilted by approx. 3 ° or more), it may cause faulty operation or delayed alarm. Use a float guide as much as possible, and also pay attention to the way the cables and chains are laid out.
3. Install a screen at the pit's inlet to remove any debris. If debris or foreign matter clog the sensor unit or inside the pit, it may cause malfunction. Inspect and clean the screen regularly.
4. Attach a chain to the ring on the side of the float sensor head in advance for added convenience. However, each 50 g of increased load on the float will increase the draft by 1 mm (0.04 in), resulting in reduced sensitivity. If using a chain to anchor the float, do not forcibly pull on the chain during inspection.
5. If the pit is completely filled with water, no oil layer will be formed even when oil is leaking. Drain the water as needed so that an oil layer can be formed.
6. Do not forcibly pull or grab and carry the cable as it may cause malfunction or compromised waterproofing.
7. Bend the tip of the discharge nozzle downward by 100 mm (3.94 in) or more when the drain valve is kept open so that an oil layer can be formed. Failure to do so may cause oil to discharge from the pit before it can form a detectable layer on the water surface, resulting in a delayed alarm or detection failure. For pits without a discharge nozzle, such as the one shown in above diagram, install an oil-water separation divider so that an oil layer can be formed.
8. Depending on the liquid flowing into the pit, install a divider to prevent waves, crosscurrents, or liquid from splashing on top of the float.
9. If the pit is too large, divide the pit using an oil separator. Oil leakage cannot be detected unless the volume of oil outflow increases in proportion to the surface area.
10. NAR300, NRR261, and sensor I/F Ex box must be installed at least 50 cm (1.64 ft) apart from each other.

## 5.3 Mounting NAR300 system

### 5.3.1 Handling precautions

When transporting NAR300, be sure to hold the float with both hands. Avoid holding the parts shown in the diagram below, and do not lift NAR300 by the top of the float sensor. In addition, do not rotate the housing. Doing so may cause device failure.

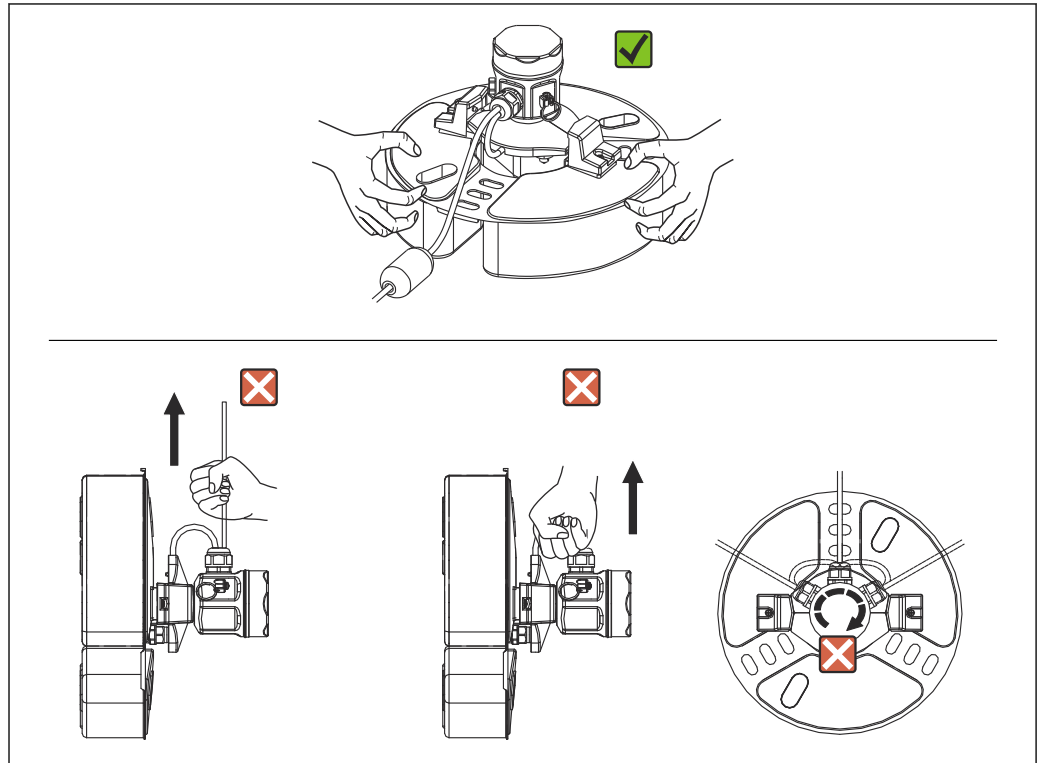

12 Handling NAR300

A0048026

### 5.3.2 Mounting the float guide

NAR300 can be mounted onto a float guide that has been installed for existing products (CFD10, CFD30, UFD10, NAR291, NAR292).

The float guide is 2 000 mm (78.74 in) in size. If a length shorter than 2 000 mm (78.74 in) is required for use, cut it to size. If a float guide longer than 2 000 mm (78.74 in) is required, contact your Endress+Hauser Sales Center.

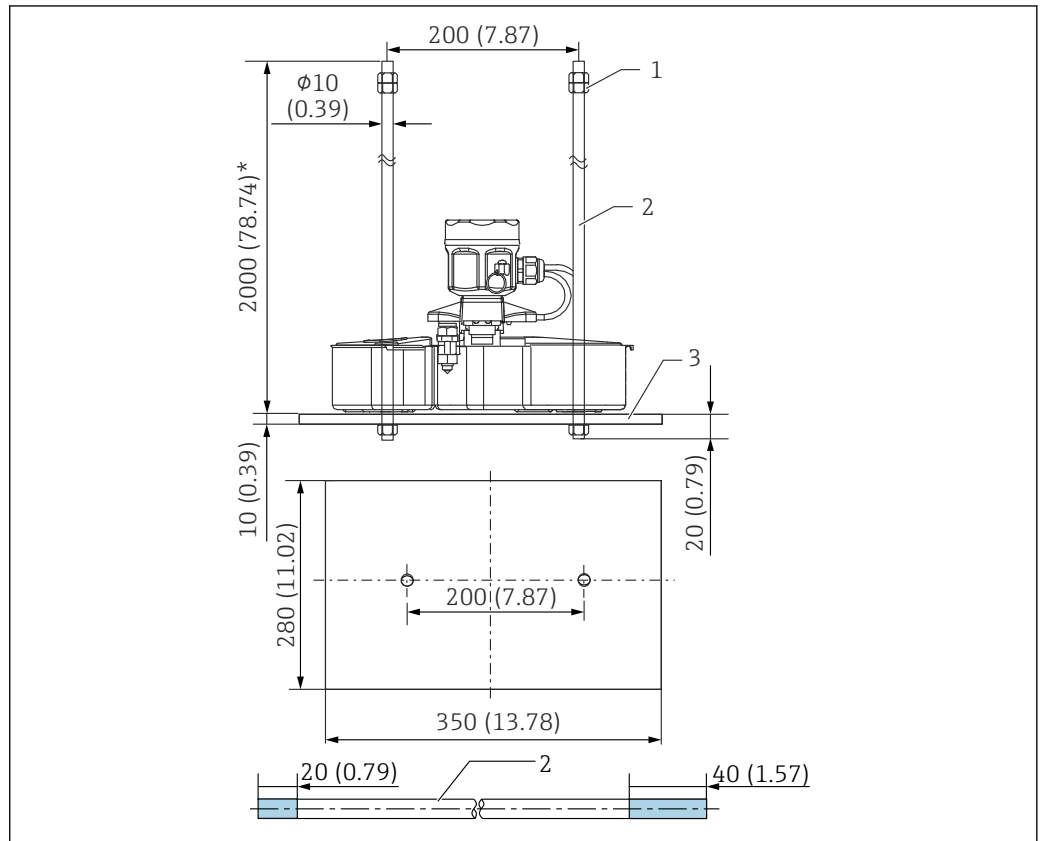

A0039907

13 NAR300, float guide

- 1 Nut (M10)
- 2 Float guide
- 3 Weight

**i** The 20 mm (0.73 in) and 40 mm (1.57 in) of the float guide in the diagram indicate the lengths of thread grooves.

### 5.3.3 NAR300-x6xxxx and sensor I/F Ex box cable mounting

#### Mounting procedure

1. Remove the intrinsically safe terminal box cover [5] and the circuit board guard [4].
2. Pass the float sensor cable [2] through the cable gland [1] and the cable entry of the intrinsically safe terminal box.
3. Connect the cable to the terminal block (refer to "Electrical connection").
4. Tighten the main unit of the cable gland [1] and the seal nut.
  - ↳ Tightening torque (main unit, seal nut): approx. 1.96 N·m (20 kgf·cm)
5. Pass the NRR262/NRR261 connecting cable through the cable entry of the terminal box, and connect it to the terminal block.
6. Secure the cable in place with a cable holder [3].
7. Attach the circuit board guard, and close the cover of the intrinsically safe terminal box.

This completes the mounting procedure.

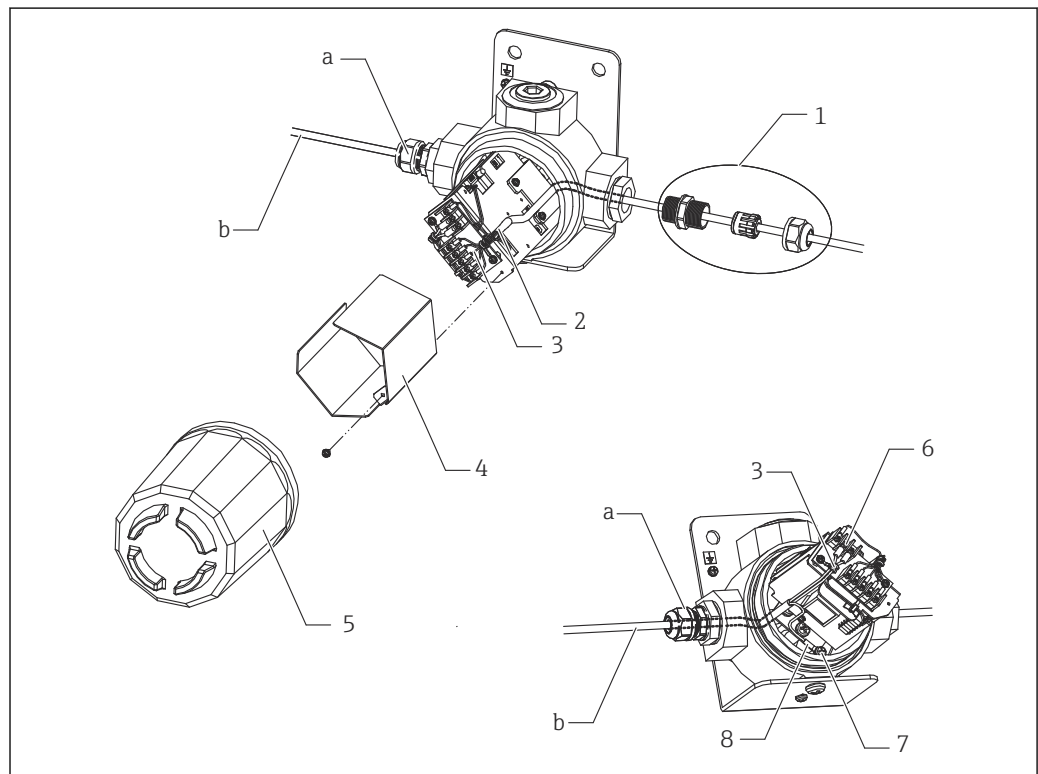

14 NAR300-x6xxxx and sensor I/F Ex box cable mounting

- a Cable gland (must be procured separately)
- b Shielded cable for NRR261/262 (must be procured separately)
- 1 Cable gland (waterproof connection)
- 2 Float sensor cable
- 3 Cable holder
- 4 Circuit board guard
- 5 Intrinsically safe terminal box cover
- 6 Screw (M3) for shielded cable
- 7 Screw (M5)
- 8 Shielded cable gland

**i** Since the cable gland "a" shown in the diagram is not supplied with products that do not have JPN Ex specifications, a water-proof cable gland that is IP67 or higher must be procured separately.

### 5.3.4 NRR261-5xx cable mounting

#### Mounting procedure

1. Remove the intrinsically safe terminal box cover [4] and the terminal block cover [3].
2. Pass the float sensor cable [2] through the cable gland [1] and the cable entry of the intrinsically safe terminal box.
3. Connect the cable to the terminal block (refer to "Electrical connection").
4. Mount the cable gland [1] according to the operating instructions.
5. Secure the cable in place with the cable holder.
6. Attach the terminal block cover, and close the cover of the intrinsically safe terminal box.

This completes the mounting procedure.

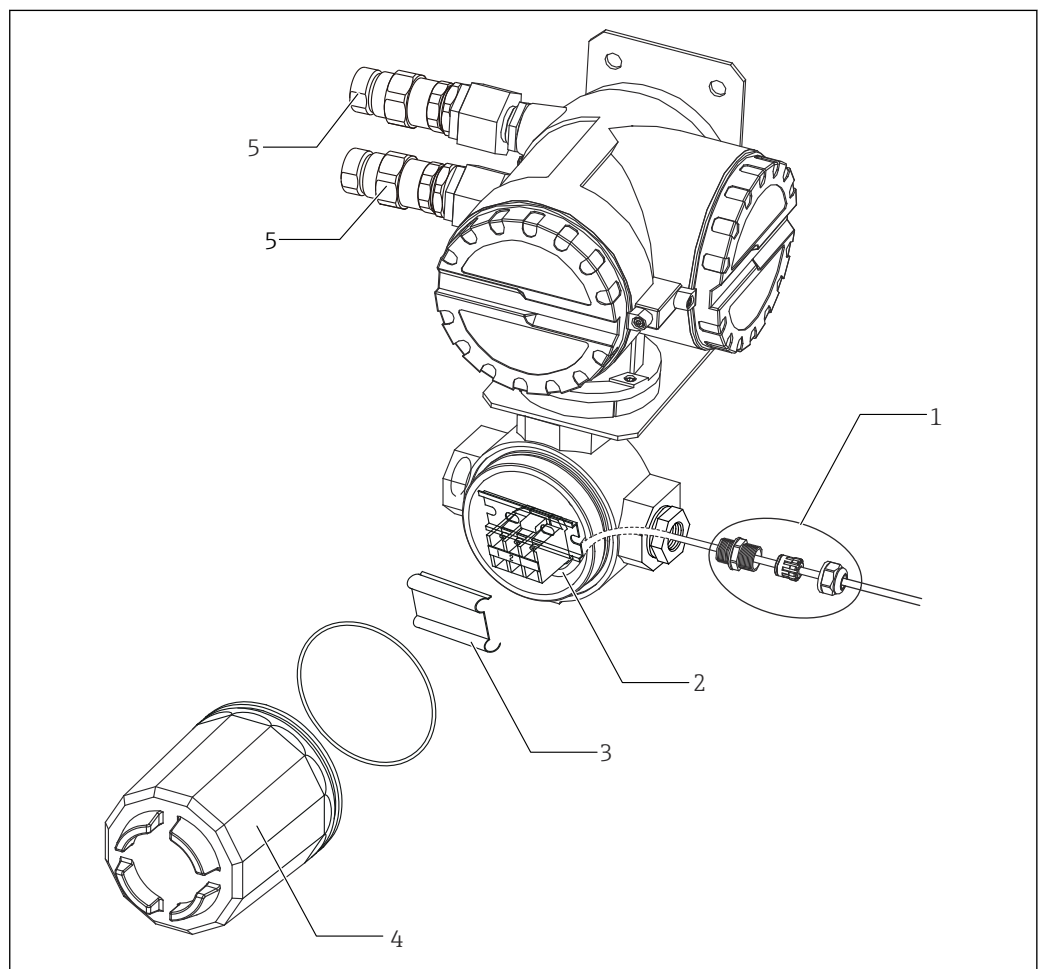

15 NRR261-5xx cable mounting

- 1 Cable gland (waterproof connection)
- 2 Float sensor cable
- 3 Terminal block cover
- 4 Intrinsically safe terminal box cover
- 5 Cable gland (Ex d) (supplied with JPN Ex specifications only)

**i** Since the cable gland [1] shown in the diagram is not supplied with products that do not have JPN Ex specifications, a water-proof cable gland that is IP67 or higher must be procured separately.

## 5.4 Adjustment

### 5.4.1 Verification of detection sensitivity with actual liquid

#### Verification of detection sensitivity with water in the bottom layer and oil in the top layer

When the tip of an electrode is pulled out from the water in the bottom layer, water may cling to the electrode tip like an icicle even when it is in the oil layer due to increased thickness of the oil layer, and this will increase the detection sensitivity by 1 to 2 mm. If accurate sensitivity verification is required, apply a small amount of neutral detergent to the electrode tip to improve water release.

#### Verification of oil layer thickness with a transparent container

Be cautious as liquid surface tension and adhesion of liquid onto the container wall may cause a reading error.

### 5.4.2 Adjustment of alarm output

Only the delay operation time (ON delay) setting of the alarm output relay can be adjusted on the converter. Time can be set using the delay trimmer. In NRR261, the delay trimmer can be found by turning off the power supply and opening the main unit's cover. In NRR262, the delay trimmer is found on the case surface. Match the setting to the necessary delay time in units of seconds. Delay operation is used to prevent false alarms by activating the alarm when an alarm state persists continuously over a certain period of time and not activating the alarm for operation that occurs within the set delay time. This can be set up to a maximum of 15 seconds for SIL specifications.

-  The response delay time of approximately 6 seconds on the detection circuit is always added to the delay time of the delay trimmer.
- When opening the main unit cover of NRR261, ensure that at least 10 minutes have passed after the power supply was cut.

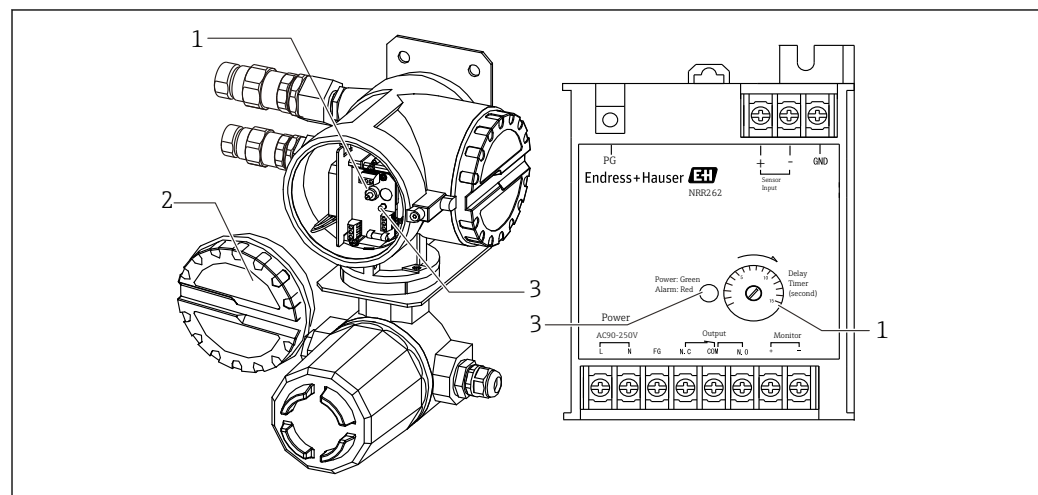

A0039891

 16 Alarm output relay

- 1 Delay trimmer
- 2 Cover
- 3 LED power (green) / alarm (red)

## 6 Electrical connection

### 6.1 NRR262-4/A/B/C wiring

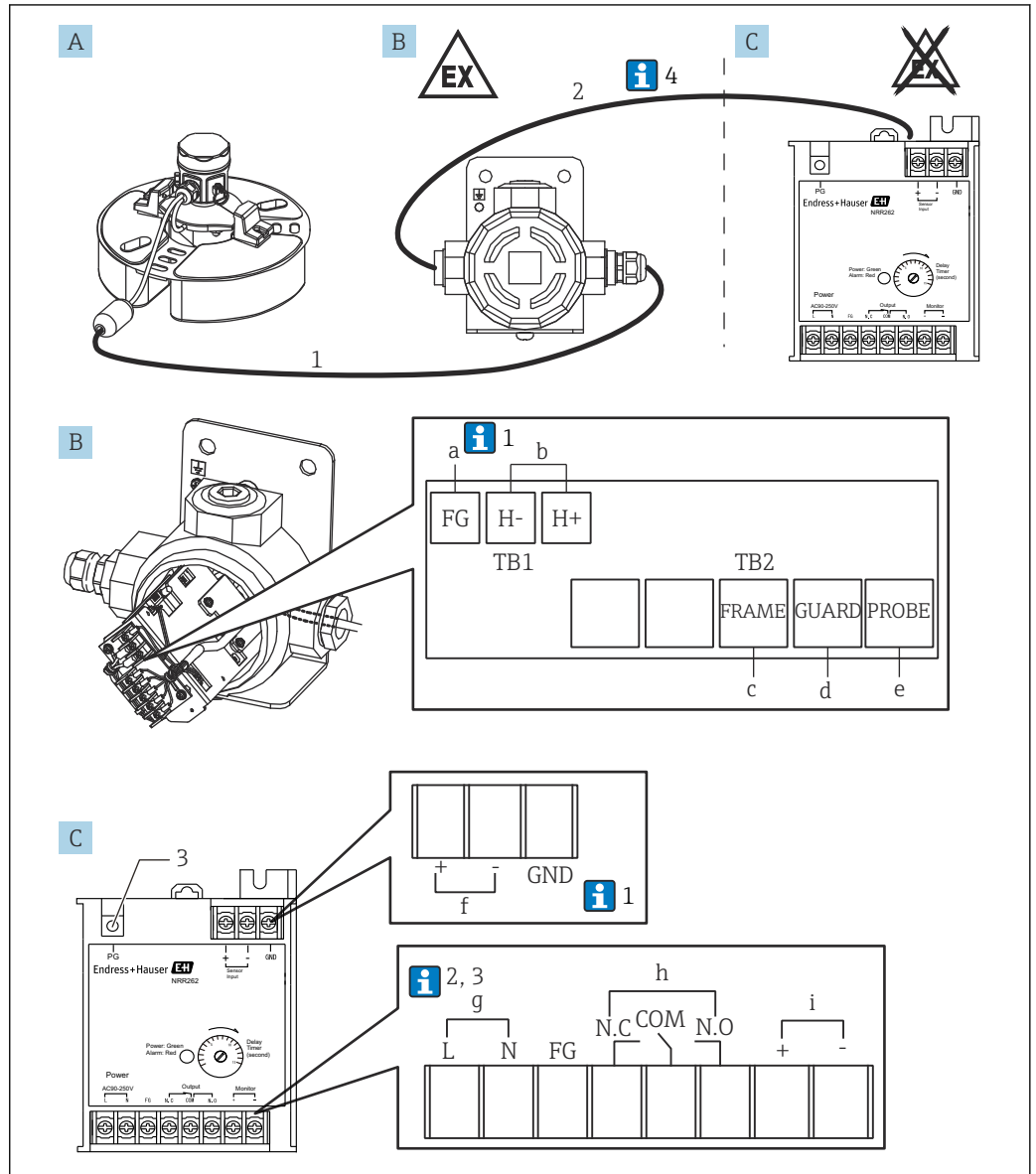

A0039908

17 Wiring of Ex [ia] converter NRR262-4/A/B/C

- A Float sensor NAR300-x6xxxx (sensor I/F Ex box is also included in the code)
- B Sensor I/F Ex box
- C Ex [ia] converter NRR262
- a Green, screw (M3) (refer to Note 1 below)
- b Output to NRR262, screw (M3)
- c Yellow, screw (M3)
- d Black, screw (M3)
- e White, screw (M3)
- f Input from sensor I/F Ex box, screw (M3)
- g Power supply: AC/DC, screw (M3)
- h Alarm output, screw (M3)
- i Checking monitor output, screw (M3)

- 1 *Using an Ex [ia]-dedicated connection cable (6 to 30 m (19.69 to 98.43 ft): included with the product depending on the option code)*
- 2 *Cable for sensor I/F Ex box and NRR262 (to be prepared by the customer)*
- 3 *For protective grounding, screw (M4)*



Below, the numbers correspond to the description in the diagram.

1. Normally, only the FG of a sensor I/F Ex box is connected to the cable's shielded wire; however, depending on the installation environment, either the GND of NRR262 alone or both the FG of the sensor I/F Ex box and the GND of NRR262 are connected.
2. When using 22 to 26 V<sub>DC</sub> power supply, the terminal number "L" becomes positive (+) and "N" becomes negative (-).
3. To maintain the Ex [ia] performance, ensure that the power supply voltage does not exceed 250 V<sub>AC</sub>50/60 Hz during normal times and 250 V<sub>DC</sub> during emergencies.
4. While cable (1) for connecting NAR300 and sensor I/F Ex box is included with the device, cable (2) for connecting sensor I/F Ex box and NRR262 is not included with the device and therefore should be procured by the customer. For more details on connection cables, refer to "Process conditions."



## 6.2 NRR261-5 wiring

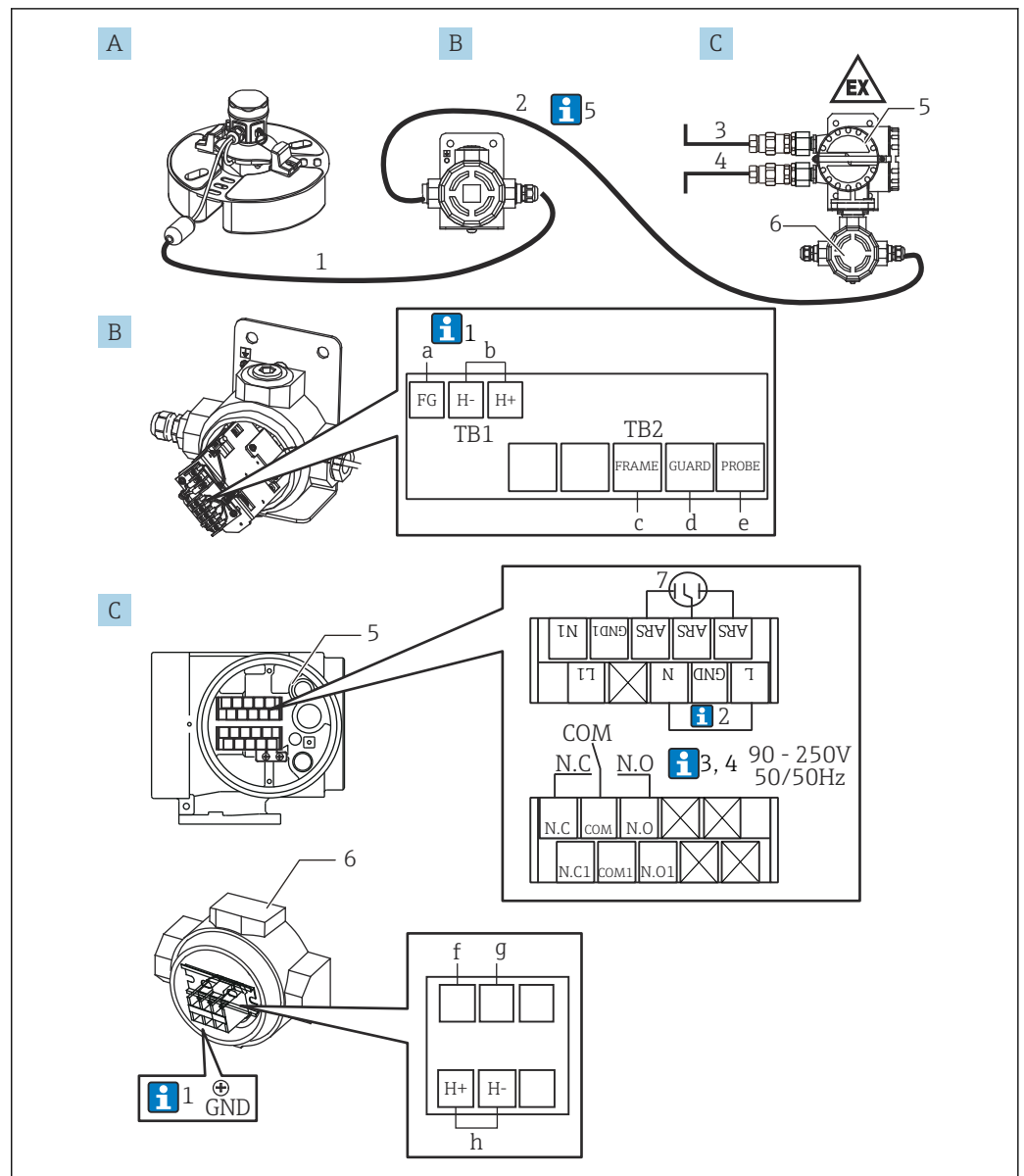

A0039909

18 Wiring of Ex d [ia] converter NRR261-5

- A Float sensor NAR300-x6xxxx (sensor I/F Ex box is also included in the code)
- B Sensor I/F Ex box
- C Ex d [ia] converter NRR261 (separate type)
- a Green, screw (M3) (refer to Note 1 below)
- b Output to NRR261-3xx, screw (M3)
- c Yellow, screw (M3)
- d Black, screw (M3)
- e White, screw (M3)
- f Blue 2, screw (M4) (already wired upon delivery)
- g Blue 3, screw (M4) (already wired upon delivery)
- h Input from sensor I/F Ex box, screw (M4)
- 1 Using an Ex [ia]-dedicated connection cable (6 to 30 m (19.69 to 98.43 ft): included with the product depending on the option code)
- 2 Cable for sensor I/F Ex box and NRR261 (to be prepared by the customer)
- 3 Power supply: AC/DC
- 4 Alarm output: Alarm/PLC/DCS, etc.

- 5 *Ex d terminal*
- 6 *Intrinsically safe terminal*
- 7 *Power supply arrester (installed), screw (M3)*



Below, the numbers correspond to the description in the diagram.

1. Normally, only the FG of a sensor I/F Ex box is connected to the cable's shielded wire; however, depending on the installation environment, either the GND of NRR262 alone or both the FG of the sensor I/F Ex box and the GND of NRR262 are connected.
2. Connect when using an AC cable with FG.
3. When using 22 to 26 V<sub>DC</sub> power supply, the terminal number "L" becomes positive (+) and "N" becomes negative (-).
4. To maintain the Ex [ia] performance, ensure that the power supply voltage does not exceed 250 V<sub>AC</sub>50/60 Hz during normal times and 250 V<sub>DC</sub> during emergencies.
5. Cable (1) which connects NAR300 and sensor I/F Ex box is included with NAR300. Cable (5) which connects sensor I/F Ex box and NRR261, alarm output cable (2) from NRR261, and power supply cable (3) for NRR261 are not included and must be procured by the customer. For more details on connection cables, refer to "Process conditions."

### 6.3 Wiring diagram

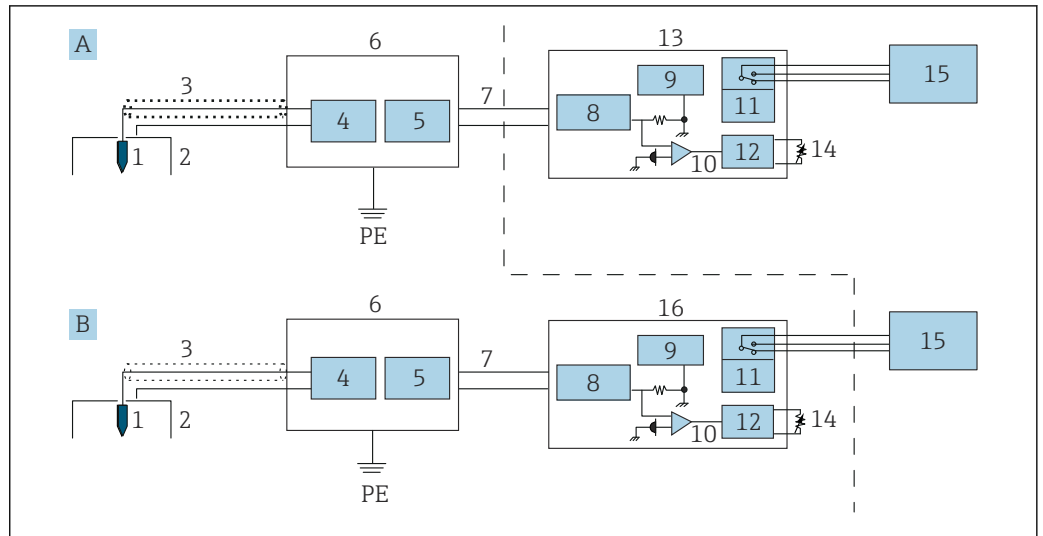

A0039910

19 Wiring diagram

- A Explosion proof-type converter system (integrated type)
- B Intrinsically safe-type converter system (separate type)
- PE Protective earth (protective grounding)
- 1 Conductivity detection electrode (sensor)
- 2 Conductivity detection electrode (float)
- 3 Dedicated cable
- 4 Conductivity detection circuit
- 5 Current output circuit
- 6 Sensor I/F Ex box
- 7 Current signal
- 8 Safety barrier
- 9 Power supply circuit
- 10 Current detection
- 11 Relay
- 12 Delay circuit
- 13 Converter NRR262
- 14 Delay trimmer
- 15 Alarm
- 16 Converter NRR261 (separate type)

## 6.4 Alarm activation principle

An oil leak detection signal detected by NAR300 float sensor is converted into a current signal inside the converter or sensor I/F Ex box. The signal is then connected to the current detection circuit through the intrinsically safe safety barrier inside the converter. In the current detection circuit, the presence or absence of an oil leak alarm signal is determined based on the size of current value, and the alarm output relay is turned ON/OFF through the operation delay circuit. The alarm delay circuit is equipped with a trimmer that can be used to set the delay time. Fail-safe operation is also available for relay contact point output, which is explained in the following "Alarm output operation table."

*Alarm output operation table*

NRR261/NRR262 terminals		Between NC and COM	Between NO and COM
State	Non-alarm	Open contact point	Closed contact point
	Oil leak alarm	Closed contact point	Open contact point
	Power OFF		
	Frozen liquid		

 Since the sensor for high temperature is exclusively for use with water, it will be in alarm mode in an empty pit.

NAR300 current value	
Non-alarm	12 mA
Oil leak alarm	16 mA
Other trouble	< 10 mA or 14 mA <

## 7 Diagnostics and troubleshooting

### 7.1 Fail-safe (alarm is output when there is no oil leak)

The following situations may cause an alarm to be output even when there is no oil leak.

Item	Description
Frozen pit water	An alarm is activated when the conductivity sensor detects an insulator due to frozen pit water.
Tilted float sensor	If the float sensor floating on pit water becomes tilted so much that the conductivity sensor is no longer submerged under water, an alarm will be activated, as the sensor will detect air as an insulator.
Empty pit	An alarm will always be activated in an empty pit.
Sensor buried in mud	If the float sensor is buried under mud and the mud becomes dry and solid, an alarm will be activated.
Essentially pure water in pit	In pit water with large electrical resistance, such as drain water, an alarm will be activated, as the conductivity sensor will recognize it as an insulator.

### 7.2 Delayed alarm (alarm is not output when there is an oil leak)

The following situations may prevent an alarm from being output even when there is an oil leak.

Item	Description
Cross-currents and waves on liquid surface	If wind and other elements cause the leaked oil surface to be very choppy, destabilizing the oil layer and pit water, the conductivity sensor will detect the pit water and no alarm will be activated.
Tilted float sensor	If the float becomes significantly tilted as a result of snow, debris, or an animal landing on one side of the float, or the float becoming tangled in or tugged by a cable or a chain, no alarm will be activated, as the conductivity sensor will detect the pit water under the oil layer.
Sunk float sensor	If snow, debris, or an animal lands on the float, the float will sink and an alarm will not be activated, as the conductivity sensor will detect the pit water under the oil layer.
Moist debris, etc.	An alarm will not be activated if conductivity is generated as a result of moist debris or algae coming in contact between the conductivity sensor and earth (float body or ground).
Oil leak during snowfall	No alarm will be activated if there is snow floating on the oil layer surface, as the conductivity sensor will recognize water due to the moisture from the melted snow.
Oil leak during snowfall	No alarm will be activated if there is snow floating on the oil layer surface, as the conductivity sensor will recognize water due to the moisture from the melted snow.



Before performing an alarm operation check, take measures to prevent the alarm system from being affected even when an oil leak alarm is activated. For the operation check process, refer to "Operation check flowchart" in the previous section. The following diagram shows the voltage check point that was described in the flowchart.

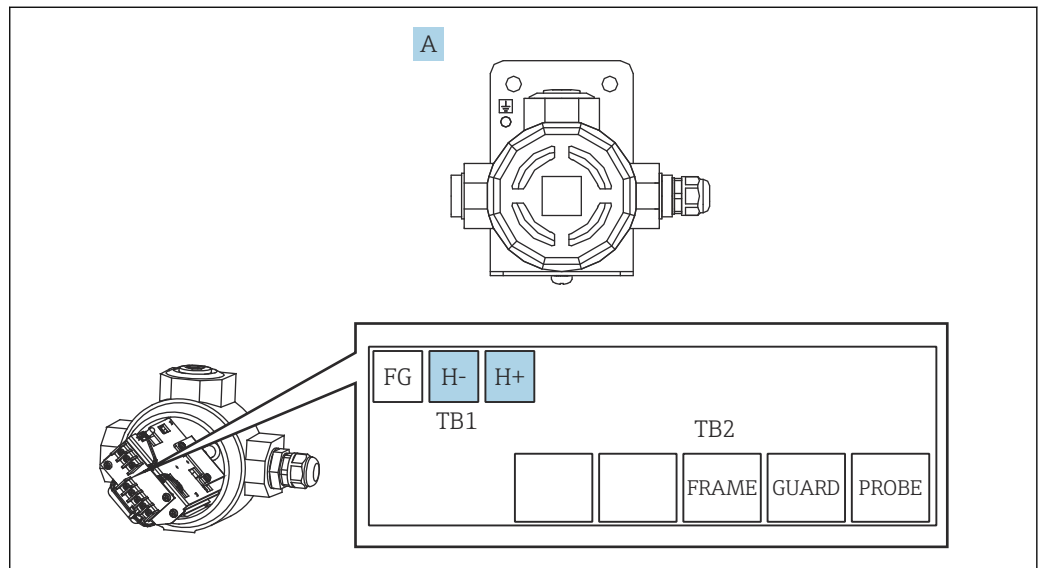

A0039874

20 Intrinsically safe terminal box

A Sensor I/F Ex box

H- Blue

H+ Blue

### 7.3.2 Converter / alarm system problems

Item	Description
LED is lit red: Normal alarm activation	An alarm is activated despite the fact that sensor voltage has not been detected. If there is no issue with the wiring between the converter and the sensor I/F Ex box, replace the converter.
LED is lit green: There is no alarm signal from the sensor	If an alarm has been activated in this condition, check the resistance value on the alarm activation output terminal of the converter by following the steps below. <ol style="list-style-type: none"> <li>1. Turn off the power supply to the alarm activation system.</li> <li>2. Disconnect the alarm activation output line from the converter.</li> <li>3. Check to ensure that the LED is continuously lit green.</li> <li>4. Measure the resistance values between 1: COM and NO and 2: COM and NC. The converter is working properly if it is 1: 0Ω (short) and 2: at least several MΩ (open). If this is not the case, replace the converter.</li> </ol>
LED is not lit: The converter is not turned on	If rated voltage is present between the L and N terminals of the converter, replace the converter. If the voltage between the L and N terminals cannot be measured, check the power supply source or power supply cable.

### 7.3.3 Cleaning the conductivity sensor unit

Normally, NAR300 checks the conduction state between the electrode tip and the float body; if there is conduction, it recognizes "water" and if there is no conduction, it recognizes "oil or air." Since the electrode holder is connected to the float body, it determines that "water" is present if a conduction state is established between the electrode tip and the holder. This prevents the alarm from being activated, resulting in a malfunction. Clean the area between the electrode tip and the holder regularly to maintain a non-conductive state.

#### Items to prepare

- Rag
- Neutral detergent

#### Cleaning procedure

1. Remove the NAR300 sensor from the pit.
2. Using a rag, clean from the electrode tip of the conductivity sensor (metal portion) to the electrode holder (metal portion) to remove any moss, algae, or dust that has become attached.
3. Clean the entire electrode unit using a properly diluted neutral detergent.

This completes the cleaning procedure.

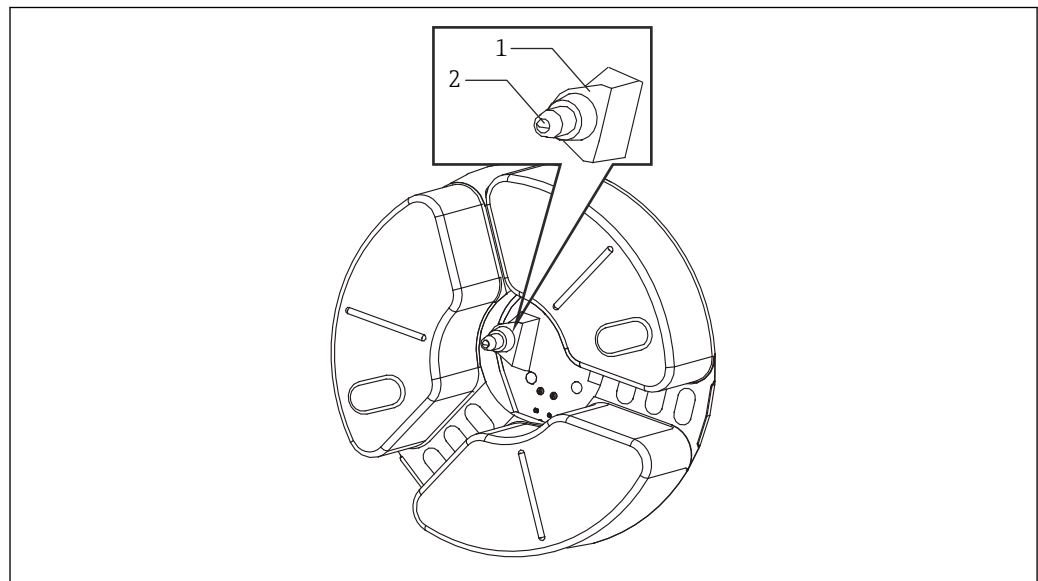

A0039904

21 Sensor cleaning

- 1 Electrode holder
- 2 Electrode tip

## 7.4 Firmware history

Date	Software version	Changes	Documentation		
			Specifications	Operating instructions	Technical information
11.2003	V1.40	Initial software	Standard	BA027N/08/ja/02.04	TI045N/08/ja/01.05
04.2015	V1.50	SIL2 obtained	High temperature	BA00403G08JA06.16	TI00457G08JA04.16



## 8 Maintenance

### 8.1 Maintenance work

No special maintenance work is required.

#### 8.1.1 Exterior cleaning

When cleaning the exterior of measuring devices, always use cleaning agents that do not attack the surface of the housing or the seals.

#### 8.1.2 Periodic maintenance

While the NAR300 float sensor is not easily affected by deposits or adhered material, conduct overall periodic inspections of the cable and wiring, etc., semi-annually along with an operation check as follows.

- Inspect and clean the sensor and the pit periodically as clogging caused by debris, foreign matter and algae may result in a malfunction. To clean the float sensor, wipe it with a soft cloth that has been soaked in water.
- Remove any accumulated debris, sand or snow on the float sensor periodically as they can lower the draft position and cause changes in sensitivity.
- Check operation after ensuring that the cables are not damaged and that there are no wiring issues (loose terminal screw, etc.).

### 8.2 Endress+Hauser services

Endress+Hauser offers a wide variety of services for maintenance such as recalibration, maintenance service or device tests.



Your Endress+Hauser Sales Center can provide detailed information on the services.

## 9 Repair

### 9.1 General information on repairs

#### 9.1.1 Repair concept

The Endress+Hauser repair concept assumes that the devices have a modular design and that repairs can be done by the Endress+Hauser Service Department or specially trained customers.

Spare parts are contained in suitable kits. They also come with relevant replacement instructions.

For more information on service and spare parts, contact the Service Department at Endress+Hauser.

#### 9.1.2 Repairs to Ex-approved devices

When carrying out repairs to Ex-approved devices, note the following:

- Repairs to Ex-approved devices may only be carried out by trained personnel or by the Endress+Hauser Service.
- Comply with the prevailing standards, national Ex-area regulations, Safety Instructions (XA) and certificates.
- Only use original spare parts from Endress+Hauser.
- When ordering a spare part, note the device designation on the nameplate. Only replace parts with identical parts.
- Carry out repairs according to the instructions. On completion of repairs, carry out the specified routine test on the device.
- Only Endress+Hauser Service may convert a certified device into a different certified variant.
- Document all repair work and conversions.

### 9.2 Spare parts

Some interchangeable device components are listed on an overview sign in the connection compartment cover.

The spare part overview sign contains the following information:

- A list of the most important spare parts for the device, including their ordering information
- The URL for the *W@M Device Viewer* ([www.endress.com/deviceviewer](http://www.endress.com/deviceviewer)):  
All the spare parts for the device, along with the order code, are listed here and can be ordered. If available, users can also download the associated Installation Instructions.

### 9.3 Endress+Hauser services

Endress+Hauser offers a wide range of services.



Your Endress+Hauser Sales Center can provide detailed information on the services.

## 9.4 Return

The requirements for safe device return can vary depending on the device type and national legislation.

1. Refer to the website for more information:  
<http://www.endress.com/support/return-material>
2. Return the device if repairs or a factory calibration are required, or if the wrong device was ordered or delivered.

## 9.5 Disposal

Observe the following notes during disposal:

- Observe valid federal/national regulations.
- Ensure proper separation and reuse of the device components.

## 10 Accessories

### 10.1 Float guide

If you have ordered a system with a float guide, construct a leveled weight so that the float sensor can land horizontally after debris and stones have been removed.

The float guide is 2 000 mm (78.74 in) in size. If a length shorter than 2 000 mm (78.74 in) is required for use, cut it to size. If a float guide longer than 2 000 mm (78.74 in) is required, contact your Endress+Hauser Sales Center.

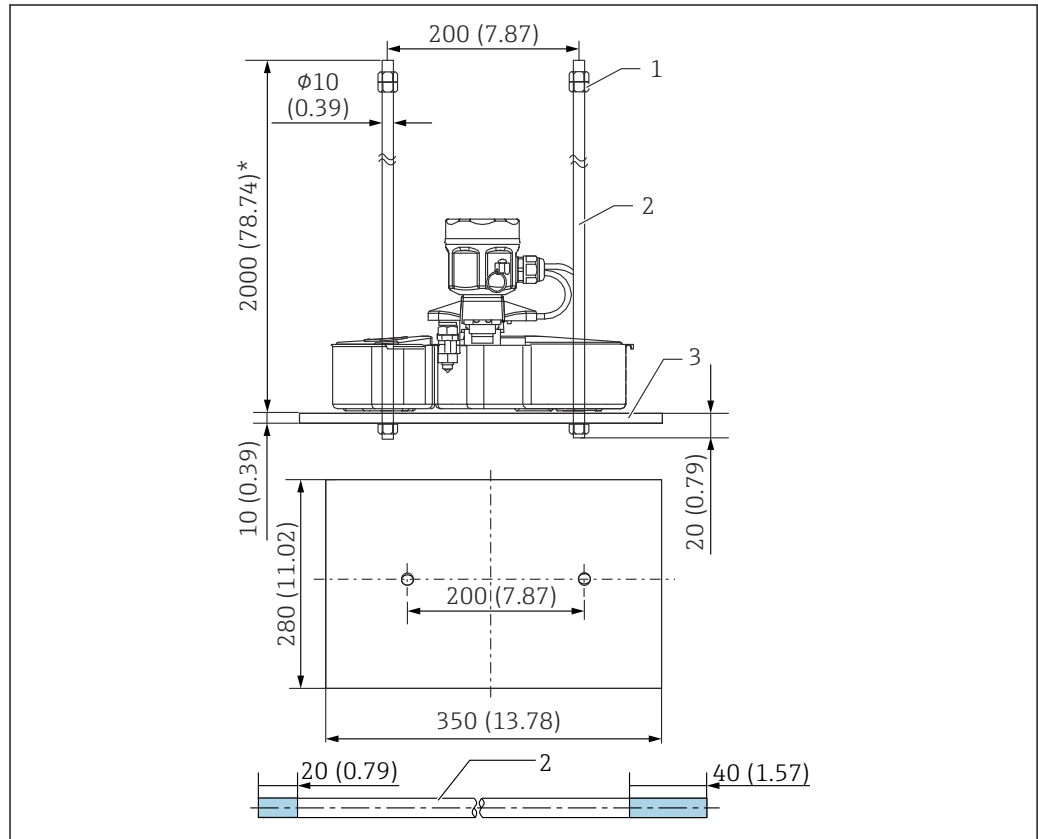

A0039907

22 Float guide

- 1 Nut (M10)
- 2 Float guide
- 3 Weight

Name	Delivered quantity	Materials
Float guide	2	SUS304
Weight	1	Different options are available from SS400 or SUS304
Nut (M10)	6	SUS304

**i** The 20 mm (0.73 in) and 40 mm (1.57 in) of the float guide in the diagram indicate the lengths of thread grooves.

## 10.2 U-bolt / cable gland (waterproof connection for JPNEx)

U-bolt (JIS F3022 B50) is used when mounting the converter. Have a pipe with an internal diameter of 50A (2B φ60.5 mm (1.985 in)) ready. Tighten and secure the cable gland after inserting the cable from NAR300.

**i** The pressure-resistant packing cable gland is supplied for the JPN Ex specification only. Always use this cable gland.

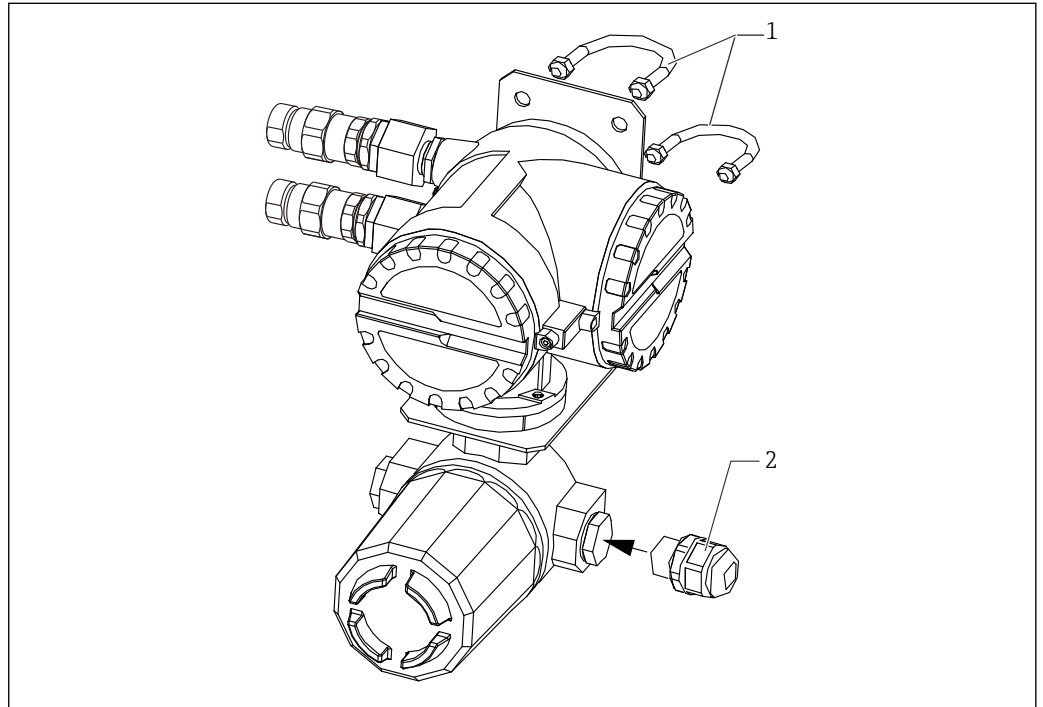

A0039892

**23** U-bolt / cable gland

1 U-bolt (JIS FF3022 B50)

2 Cable gland (waterproof connection)

Name		Delivered quantity	Materials
U-bolt		2	Iron (chromate)
U-bolt accessory	Nut	4	
	Flat washer	4	
Cable gland (waterproof connection)		1	Nylon

# Index

## Symbols

Application . . . . .	7
Safety Instructions	
Basic . . . . .	7
Operational safety . . . . .	8
Measured materials . . . . .	7
Declaration of Conformity . . . . .	8
Maintenance . . . . .	41
Requirements for personnel . . . . .	7

## C

CE mark . . . . .	8
Cleaning	
Exterior cleaning . . . . .	41

## D

Designated use . . . . .	7
Disposal . . . . .	43
Document	
Function . . . . .	4
Document function . . . . .	4

## E

Endress+Hauser services	
Maintenance . . . . .	41
Repair . . . . .	42
Exterior cleaning . . . . .	41

## P

Product description . . . . .	9
Product design . . . . .	9
Product safety . . . . .	8

## R

Recalibration . . . . .	41
Repair concept . . . . .	42
Return . . . . .	43

## S

Safety Instructions (XA) . . . . .	6
------------------------------------	---

## W

Workplace safety . . . . .	7
----------------------------	---





71661263

[www.addresses.endress.com](http://www.addresses.endress.com)

---