

Technical Information

Oil leak detector NAR300 for high temperature

Oil leak detector equipped with conductivity sensor



Application

This system is installed on an oil retaining wall in a tank or in a sump pit near a pump yard, and it provides the ultimate leak detection function for oils, such as petrochemicals and vegetable oils. A sensor with a conductive detection function is used to monitor the detection conditions. This system ensures the safety of the tank yard through a precise and simple device design that is suitable for pits where anti-freeze steam is emitted and the temperature becomes high ($\leq 100\text{ }^{\circ}\text{C}$ ($212\text{ }^{\circ}\text{F}$)).

Flame-proof system

Using transmitter NRR261 for outdoor installation, it is possible to connect directly to the switch input mechanism, such as an existing liquid level transmitter, and send an alarm to the host controller.

Intrinsically safe system

An alarm system that is independent from tank gauging can be configured by combining transmitter NRR262 for indoor installation with a sensor I/F Ex box for outdoor installation.

Features

- SIL2: Certified for safety instrumented systems in the process industry
- Conductive sensor: Distinguishes between water and other substances (oil and air)
- No moving parts, long service life and reduced maintenance costs
- Safe and reliable fail-safe function with alarm output in the event of power failure, frozen pit water, etc.
- Detection mechanism that is not affected by the dielectric constant of the object to be detected, as long as the oil is water-insoluble
- Mechanical construction that is less susceptible to material deposits
- Ex [ia] structure

NOTICE

TIIS specifications

These operating instructions are not intended for products with TIIS specifications.

- ▶ If you are using a product with TIIS specifications, download and refer to TI00045G/33/JA/09.22 or an earlier version from our website (www.endress.com/downloads).

Table of contents

Document information	3
Symbols used	3
Documentation	5
Function and system design	6
Intrinsically safe system (separate type) Ex ia IIB T4	6
Flame-proof system (separate type) Ex d [ia] IIB T4	6
Operating principles	8
Operating principles of alarm activation	9
Operating conditions	10
Input and output	11
Ex d [ia] transmitter NRR261	11
Ex [ia] transmitter NRR262	11
Power supply	12
Float sensor NAR300	12
Ex [ia] sensor I/F Ex box	12
Ex d [ia] converter NRR261	12
Ex [ia] converter NRR262	12
Electrical connection	13
NRR262-4/A/B/C wiring	13
NRR261-5 wiring	15
Wiring diagram	16
Installation	17
Installation conditions	17
Mounting NAR300 system	19
Environment	21
Protection class	21
Process	22
Float sensor NAR300	22
Sensor I/F Ex box / Converter NRR261/NRR262	22
Mechanical construction	23
NAR300 system dimensions	23
Weight of the NAR300 system	26
Detection sensitivity	26
Materials	26
Certificates and approvals	28
CE mark	28
Ex approval	28
Functional safety certification	29
Order information	30
Accessories	31
Float guide	31
U-bolt / cable gland (waterproof connection for JPNEEx)	32

Document information

Symbols used

Safety symbols



This symbol alerts you to a dangerous situation. Failure to avoid this situation will result in serious or fatal injury.



This symbol alerts you to a dangerous situation. Failure to avoid this situation can result in serious or fatal injury.



This symbol alerts you to a dangerous situation. Failure to avoid this situation can result in minor or medium injury.



This symbol contains information on procedures and other facts which do not result in personal injury.

Electrical symbols



Alternating current



Direct current and alternating current



Direct current



Ground connection

A grounded terminal which, as far as the operator is concerned, is grounded via a grounding system.

Protective earth (PE)

Ground terminals that must be connected to ground prior to establishing any other connections.

The ground terminals are located on the interior and exterior of the device:

- Interior ground terminal: protective earth is connected to the mains supply.
- Exterior ground terminal: device is connected to the plant grounding system.

Tool symbols



Phillips head screwdriver



Flat blade screwdriver



Torx screwdriver



Allen key



Open-ended wrench

Symbols for certain types of information and graphics



Procedures, processes or actions that are permitted



Procedures, processes or actions that are preferred



Procedures, processes or actions that are forbidden



Indicates additional information



Reference to documentation



Reference to graphic



Notice or individual step to be observed

1, 2, 3

Series of steps



Result of a step



Visual inspection



Operation via operating tool



Write-protected parameter

1, 2, 3, ...

Item numbers

A, B, C, ...

Views



Safety instructions

Observe the safety instructions contained in the associated Operating Instructions



Temperature resistance of the connection cables

Specifies the minimum value of the temperature resistance of the connection cables

Documentation

The following documents can be found in the Download area of our website (www.endress.com/downloads).



For an overview of the scope of the associated Technical Documentation, refer to the following: *W@M Device Viewer* (www.endress.com/deviceviewer): Enter the serial number from nameplate

Technical Information (TI)

Planning aid

The document contains all the technical data on the device and provides an overview of the accessories and other products that can be ordered for the device.

Brief Operating Instructions (KA)

Guide that takes you quickly to the 1st measured value

The Brief Operating Instructions contain all the essential information from incoming acceptance to initial commissioning.

Operating Instructions (BA)

The Operating Instructions contain all the information that is required in various phases of the life cycle of the device: from product identification, incoming acceptance and storage, to mounting, connection, operation and commissioning through to troubleshooting, maintenance and disposal.

Safety Instructions (XA)

Depending on the approval, the following Safety Instructions (XA) are supplied with the device. They are an integral part of the Operating Instructions.



The nameplate indicates the Safety Instructions (XA) that are relevant to the device.

Function and system design

The oil leak detector NAR300 system is available in two configurations for a variety of applications.

Intrinsically safe system (separate type) Ex ia IIB T4

In this system, Ex [ia] transmitter NRR262 is installed in a non-hazardous location, such as an instrument room, and alarm output is imported by the indoor alarm panel and the host instrumentation receiver.

The signal from the NAR300 float sensor is imported by the Ex [ia] wiring of transmitter NRR262 via a sensor I/F Ex box. For the connection between the float sensor and the sensor I/F Ex box, a dedicated cable and cable entry are provided by Endress+Hauser.

- JPN Ex: NAR300-26xxxx + NRR262-4x
- ATEX: NAR300-A6xxxx + NRR262-Ax
- IECEx: NAR300-B6xxxx + NRR262-Bx
- FM: NAR300-C6xxxx + NRR262-Cx

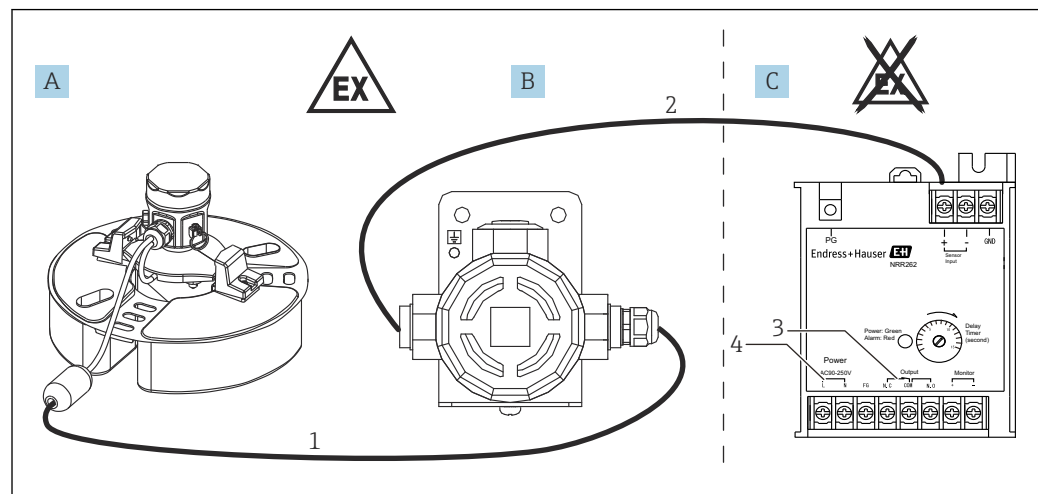

A0039921

1 System configuration 1

- A Float sensor NAR300-x6xxxx
 B Sensor I/F Ex box
 C Ex [ia] transmitter NRR262
 1 Ex [ia] dedicated connection cable (6 to 30 m (19.69 to 98.43 ft))
 2 Cable for sensor I/F Ex box and transmitter (refer to Process conditions)
 3 Alarm output: Alarm/PLC/DCS, etc.
 4 Power supply (AC/DC)

Flame-proof system (separate type) Ex d [ia] IIB T4

This system can handle the entire process, from oil leak detection to alarm output, at hazardous outdoor locations.

Ex [ia] specification is used in the circuitry from the NAR300 float sensor to the wiring terminal box of Ex d [ia] transmitter NRR261. The signal from the NAR300 float sensor is imported by the Ex [ia] wiring of transmitter NRR261 via a sensor I/F Ex box. Ex d wiring is used from the main unit of Ex d [ia] transmitter NRR261, and it can be connected directly to the junction box that is installed in a yard or to the liquid level transmitter relay input.

- JPN Ex: NAR300-26xxxx x + NRR261-5xx
- For ATEX, IECEx and FM specifications, contact your nearest Endress+Hauser Sales Center or distributor.

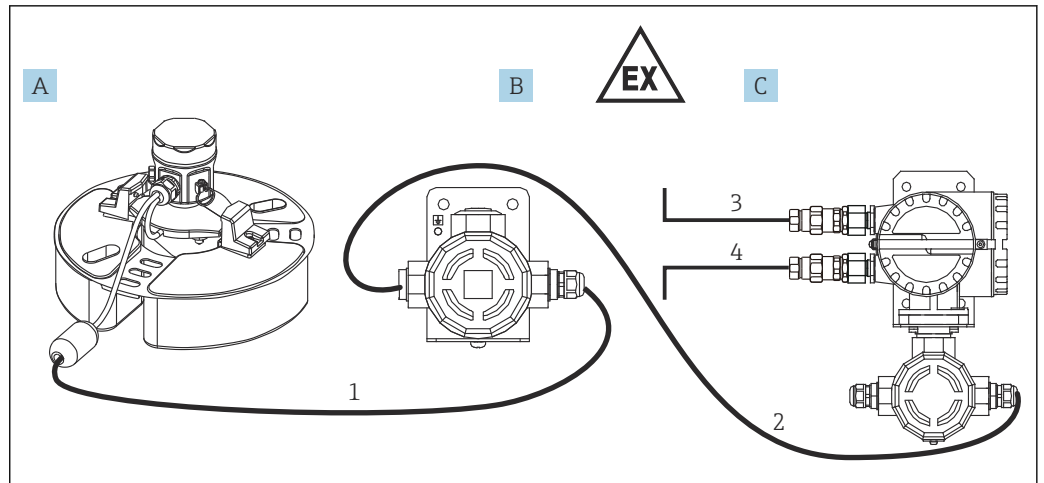

A0039922

2 System configuration 2

A Float sensor NAR300-x6xxxx

B Sensor I/F Ex box

C Ex d [ia] transmitter NRR261 (separate type)

1 Ex [ia]-dedicated connection cable (6 to 30 m (19.69 to 98.43 ft))

2 Cable for sensor I/F Ex box and transmitter (refer to Process conditions)

3 Alarm output: Alarm/PLC/DCS, etc.

4 Power supply (AC/DC)

Operating principles

Conductive sensor

The conductive sensor detects and determines whether there is a conductive substance (water, OFF) or non-conductive substance (oil, ON) between the electrode and the float body.

Name	Water	Oil
Conductive sensor	OFF	ON

i The high-temperature specification is exclusively for applications in which there is always water in the pit.

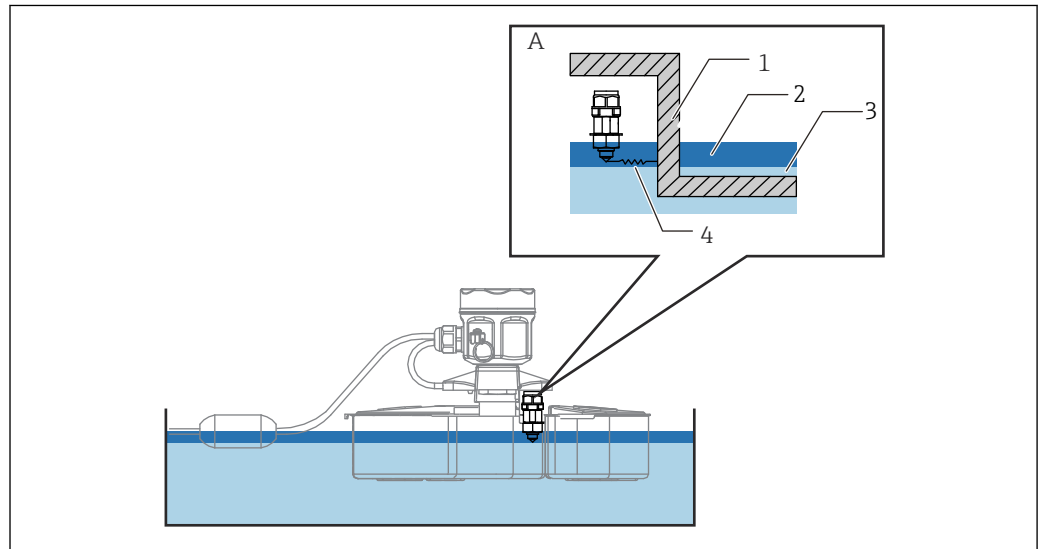

A0039923

3 Principles of the sensors

- A Conductive sensor
- 1 Metal portion of the float body
- 2 Oil
- 3 Water
- 4 Measuring permittivity

Detection in water-filled pits

1. The conductive sensor continuously monitors conductivity between the probe and the float body.
2. Normally, the conductive sensor detects water, which is a conductive substance.
3. If an accident causes oil flow and an oil layer begins to form on the water surface, the conductive sensor will detect the non-conductive oil and the alarm status switches to ON.

Operating principles of alarm activation

The oil leak detection signal detected by the NAR300 float sensor is converted to a current signal in the transmitter or the sensor I/F Ex box. After this, it is connected to the current detection circuit via the Ex [ia] safety barrier in the transmitter. In the current detection circuit, the presence or absence of an oil leak alarm signal is determined by the magnitude of electrical current values, and the alarm output relay is turned on or off by the operation delay circuit. The delay time can be set, and there is a trimmer for setting the delay time in the alarm delay circuit. A fail-safe function is also available for the relay contact output (refer to the "Alarm output table" below).

Alarm output table

NRR261/NRR262 terminals		Between NC and COM	Between NO and COM
Condition	Non-alarm	Contact point is open	Contact point is closed
	Oil leak alarm	Contact point is closed	Contact point is open
	Power OFF		
	Frozen liquid		

NAR300 current value	
Non-alarm	12 mA
Oil leak alarm	16 mA
Other trouble	< 10 mA or 14 mA <

The high-temperature sensor is exclusively for use in the presence of water; an alarm will be activated in an empty pit. The only adjustment that can be made on the transmitter is the delayed activation time (ON delay) setting for the alarm output relay. Time is set on the delay trimmer. In NRR261, the delay trimmer can be found by turning off the power and opening the main unit's cover. In NRR262, the indicator for adjusting the delay trimmer is found on the case surface. Match the setting to the necessary delay time in units of seconds. Delayed activation is used to prevent a false alarm by recognizing an alarm condition that continues over a certain period of time as an alarm while not outputting an alarm when the alarm condition stops within the delay time setting. This can be set up to a maximum of 15 seconds for SIL specifications.

i A response delay time in the detection circuit of approximately 6 seconds is always added to the delay time of the delay trimmer.

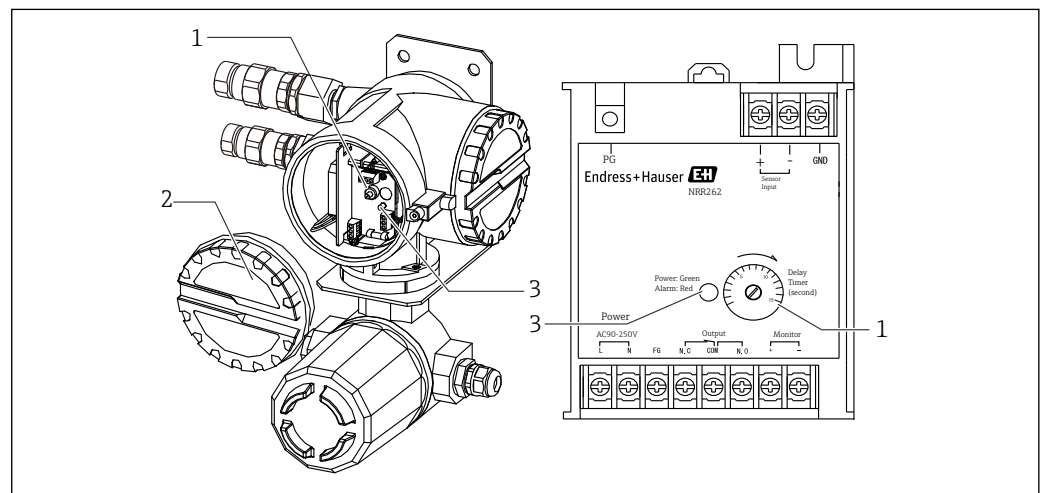

4 Transmitter NRR261 (left) / transmitter NRR262 (right)

- 1 Delay trimmer
- 2 Cover
- 3 LED power (green) / alarm (red)

Operating conditions**Detection sensitivity**

If the electrode tip is pulled out of the lower-layer water due to increased thickness of the oil layer, water may cling onto the electrode tip like an icicle even if the electrode tip is in oil. In this case, detection sensitivity may increase by 1 to 2 mm (0.04 to 0.08 in). When an accurate sensitivity check is required, apply a small amount of neutral detergent to the electrode tip to keep water from clinging to the electrode.

Water-filled pit: Set to $10 (0.39) \pm 1$ mm (0.04 in) with kerosene at the time of shipment from the factory

-  ■ Set with oil (kerosene: specific gravity approx. 0.8), lower-layer water (water: specific gravity approx. 1.0), static level condition and/or without surface tension.
- Because the NAR300 high-temperature specification lacks a tuning fork sensor, it cannot be used for applications in which there is no pit water.

Pit water*Do not use in sea water*

The oil leak detector is not designed for use in sea water. The following problems may occur if it is used in sea water:

- Failed or delayed alarm when overturned by waves
- Delayed alarm caused by generation of a bypass circuit between the conductive sensor and the float body due to salt coating
- Corrosion of the float sensor caused by sea water

Special pit water

- If the float sensor is used in certain special pit water, such as pit water containing solvents, it may become corroded or damaged.
- It cannot measure highly hydrophilic liquids, such as alcohol.

Pit water with high electrical resistance

Use in pit water with high electrical resistance, such as pure water, may activate the alarm. Ensure that the conductivity of pit water is at least $10 \mu\text{S}/\text{cm}$ (not more than $100 \text{k}\Omega \cdot \text{cm}$).

Example, pure water: 1 to $0.1 \mu\text{S}/\text{cm}$ (1 to $10 \text{M}\Omega \cdot \text{cm}$)

Frozen pit water

If ice forms in the pit, the alarm may be triggered (fail-safe function). Implement anti-freeze measures to prevent freezing.

Input and output

Ex d [ia] transmitter NRR261	Contact output	1SPDT
	Maximum contact rating	250 V _{AC} , 1 A, 100 VA 100 V _{DC} : 1 A, 25 W
	Fail-safe function	Fail safe function: When the power is off, when frozen (see "Alarm output operation table")

Ex [ia] transmitter NRR262	Contact output	1SPDT
	Maximum contact rating	250 V _{AC} , 1 A, 100 VA 100 V _{DC} : 1 A, 25 W
	Fail-safe function	Fail safe function: When the power is off, when frozen (see "Alarm output operation table")

Power supply

Float sensor NAR300	Power supply	Supplied by the converter
	I/O cable	Dedicated shielded cable (PVC) / with cable float (standard 6 m (19.69 ft))
Ex [ia] sensor I/F Ex box	Power supply	Supplied by NRR261 or NRR262
	Cable entry	<ul style="list-style-type: none"> ▪ NAR300 (float sensor) side: G1/2, with cable gland ▪ NRR261 or NRR262 (converter) side: G1/2, NPT1/2, M20
Ex d [ia] converter NRR261	Permissible power-supply voltage range	<ul style="list-style-type: none"> ▪ AC power-supply type: 90 to 250 V_{AC}, 50/60 Hz ▪ DC power-supply type: 22 to 26 V_{DC} (built-in power supply arrester)
	Maximum power consumption	<ul style="list-style-type: none"> ▪ AC power-supply type: 2 VA ▪ DC power-supply type: 3 W
	Power supply port	<ul style="list-style-type: none"> ▪ G3/4 x2 (Ex d), G1/2 x1 (Ex ia) ▪ G1/2 x2 (Ex d), G1/2 x1 (Ex ia) ▪ NPT3/4 x2 (Ex d), NPT1/2 x1 (Ex ia) ▪ NPT1/2 x2 (Ex d), NPT1/2 x1 (Ex ia) ▪ M25 x2 (Ex d), M20 x1 (Ex ia) ▪ M20 (Ex d), M20 x1 (Ex ia) ▪ JPNEx explosion-proof specifications are equipped with cable gland model SFLU
	Lightning arrester	Built-in (power supply arrester)
Ex [ia] converter NRR262	Permissible power-supply voltage range	<ul style="list-style-type: none"> ▪ AC power-supply type: 90 to 250 V_{AC}, 50/60 Hz ▪ DC power-supply type: 22 to 26 V_{DC} (built-in power supply arrester AV3P-2)
	Maximum power consumption	<ul style="list-style-type: none"> ▪ AC power-supply type: 2 VA ▪ DC power-supply type: 3 W
	Lightning arrester	Built-in (power supply arrester)

Electrical connection

NRR262-4/A/B/C wiring

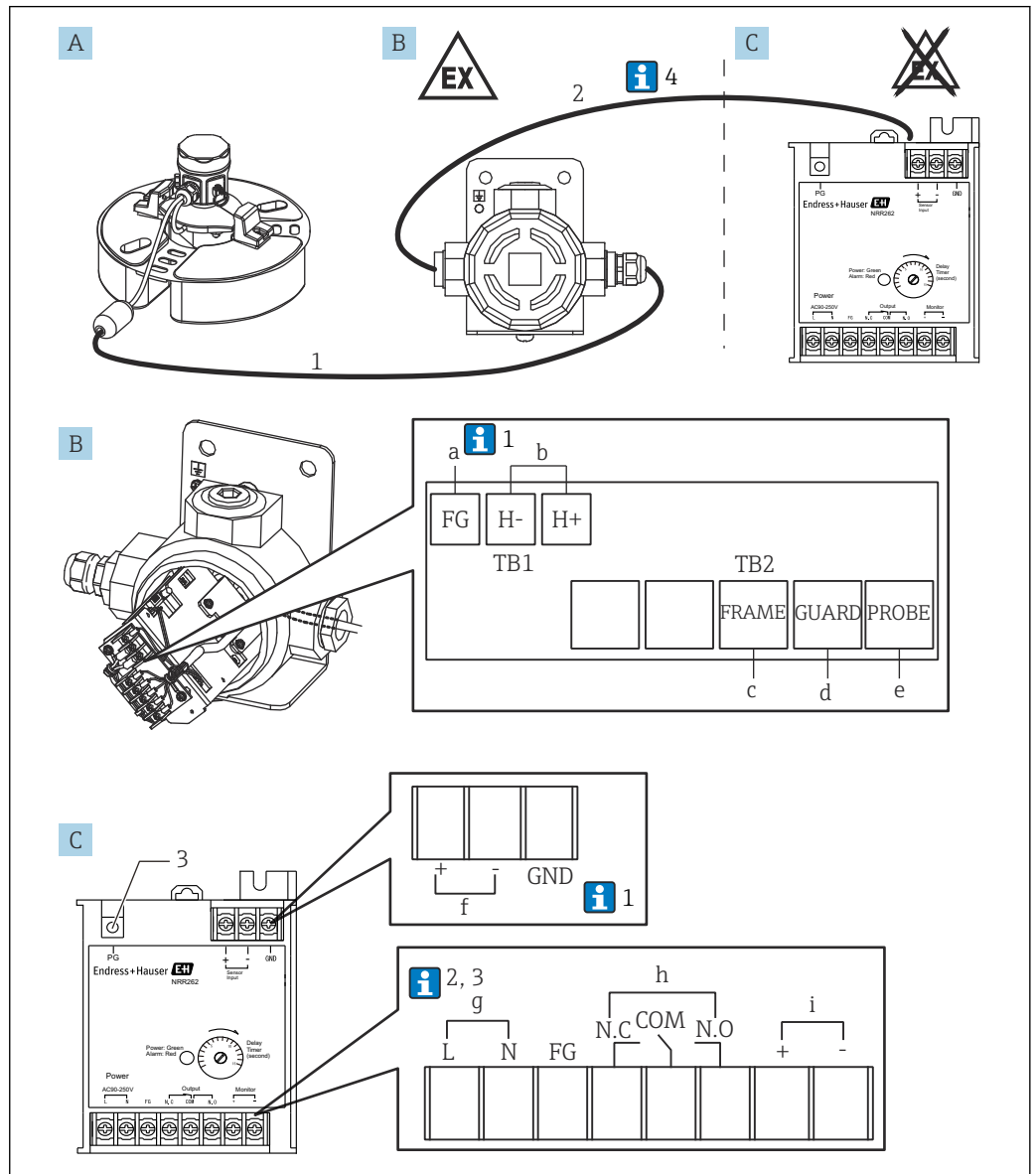

A0039908

5 Wiring of Ex [ia] converter NRR262-4/A/B/C

- A Float sensor NAR300-x6xxxx (sensor I/F Ex box is also included in the code)
- B Sensor I/F Ex box
- C Ex [ia] converter NRR262
- a Green, screw (M3) (refer to Note 1 below)
- b Output to NRR262, screw (M3)
- c Yellow, screw (M3)
- d Black, screw (M3)
- e White, screw (M3)
- f Input from sensor I/F Ex box, screw (M3)
- g Power supply: AC/DC, screw (M3)
- h Alarm output, screw (M3)
- i Checking monitor output, screw (M3)
- 1 Using an Ex [ia]-dedicated connection cable (6 to 30 m (19.69 to 98.43 ft): included with the product depending on the option code)
- 2 Cable for sensor I/F Ex box and NRR262 (to be prepared by the customer)
- 3 For protective grounding, screw (M4)

i Below, the numbers correspond to the description in the diagram.

1. Normally, only the FG of a sensor I/F Ex box is connected to the cable's shielded wire; however, depending on the installation environment, either the GND of NRR262 alone or both the FG of the sensor I/F Ex box and the GND of NRR262 are connected.
2. When using 22 to 26 V_{DC} power supply, the terminal number "L" becomes positive (+) and "N" becomes negative (-).
3. To maintain the Ex [ia] performance, ensure that the power supply voltage does not exceed 250 V_{AC}50/60 Hz during normal times and 250 V_{DC} during emergencies.
4. While cable (1) for connecting NAR300 and sensor I/F Ex box is included with the device, cable (2) for connecting sensor I/F Ex box and NRR262 is not included with the device and therefore should be procured by the customer. For more details on connection cables, refer to "Process conditions."

NRR261-5 wiring

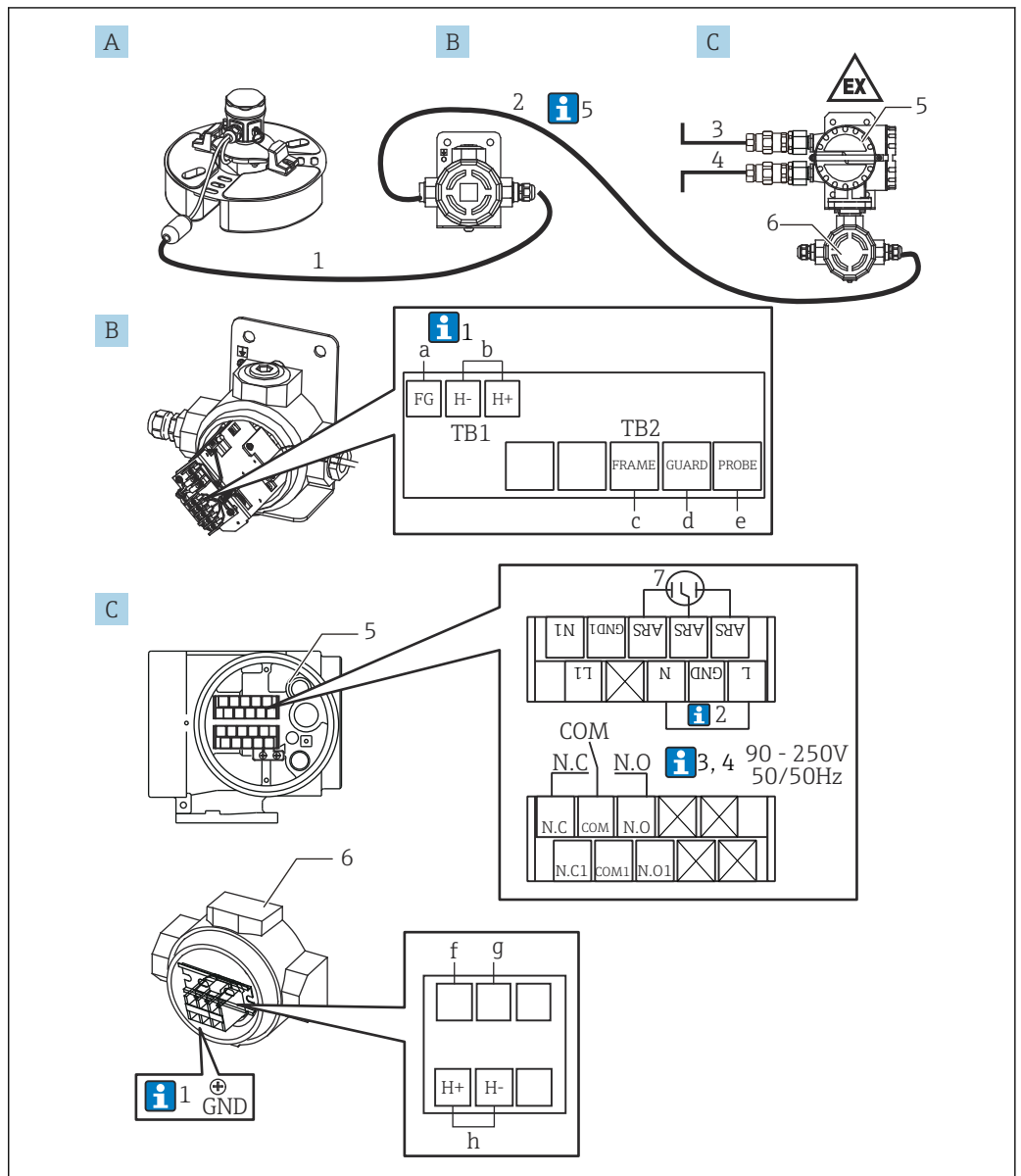

A0039909

6 Wiring of Ex d [ia] converter NRR261-5

- A Float sensor NAR300-x6xxxx (sensor I/F Ex box is also included in the code)
- B Sensor I/F Ex box
- C Ex d [ia] converter NRR261 (separate type)
- a Green, screw (M3) (refer to Note 1 below)
- b Output to NRR261-3xx, screw (M3)
- c Yellow, screw (M3)
- d Black, screw (M3)
- e White, screw (M3)
- f Blue 2, screw (M4) (already wired upon delivery)
- g Blue 3, screw (M4) (already wired upon delivery)
- h Input from sensor I/F Ex box, screw (M4)
- 1 Using an Ex [ia]-dedicated connection cable (6 to 30 m (19.69 to 98.43 ft): included with the product depending on the option code)
- 2 Cable for sensor I/F Ex box and NRR261 (to be prepared by the customer)
- 3 Power supply: AC/DC
- 4 Alarm output: Alarm/PLC/DCS, etc.
- 5 Ex d terminal
- 6 Intrinsically safe terminal
- 7 Power supply arrester (installed), screw (M3)

i Below, the numbers correspond to the description in the diagram.

1. Normally, only the FG of a sensor I/F Ex box is connected to the cable's shielded wire; however, depending on the installation environment, either the GND of NRR262 alone or both the FG of the sensor I/F Ex box and the GND of NRR262 are connected.
2. Connect when using an AC cable with FG.
3. When using 22 to 26 V_{DC} power supply, the terminal number "L" becomes positive (+) and "N" becomes negative (-).
4. To maintain the Ex [ia] performance, ensure that the power supply voltage does not exceed 250 V_{AC}50/60 Hz during normal times and 250 V_{DC} during emergencies.
5. Cable (1) which connects NAR300 and sensor I/F Ex box is included with NAR300. Cable (5) which connects sensor I/F Ex box and NRR261, alarm output cable (2) from NRR261, and power supply cable (3) for NRR261 are not included and must be procured by the customer. For more details on connection cables, refer to "Process conditions."

Wiring diagram

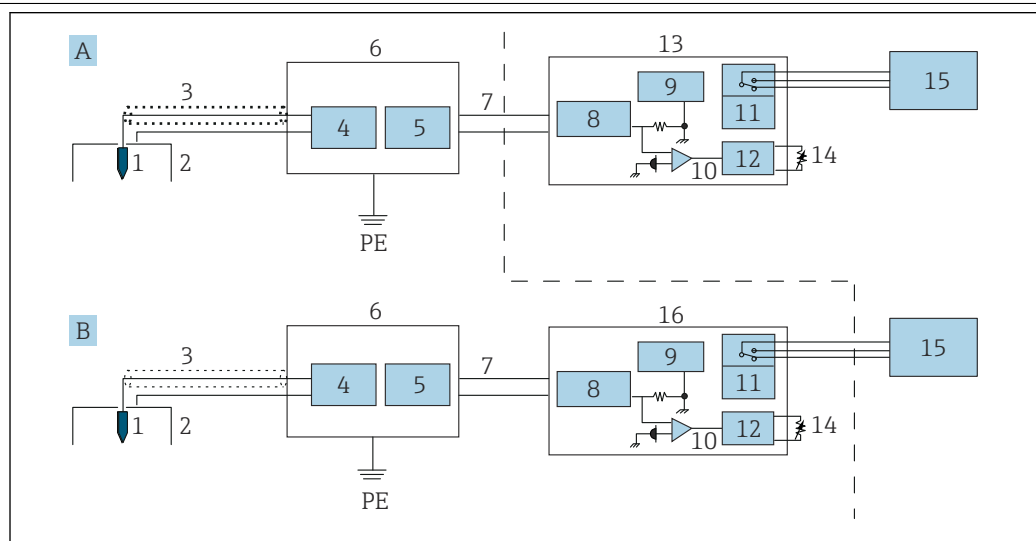

A0039910

7 Wiring diagram

- A Explosion proof-type converter system (integrated type)
 B Intrinsically safe-type converter system (separate type)
 PE Protective earth (protective grounding)
 1 Conductivity detection electrode (sensor)
 2 Conductivity detection electrode (float)
 3 Dedicated cable
 4 Conductivity detection circuit
 5 Current output circuit
 6 Sensor I/F Ex box
 7 Current signal
 8 Safety barrier
 9 Power supply circuit
 10 Current detection
 11 Relay
 12 Delay circuit
 13 Converter NRR262
 14 Delay trimmer
 15 Alarm
 16 Converter NRR261 (separate type)

Installation

Installation conditions

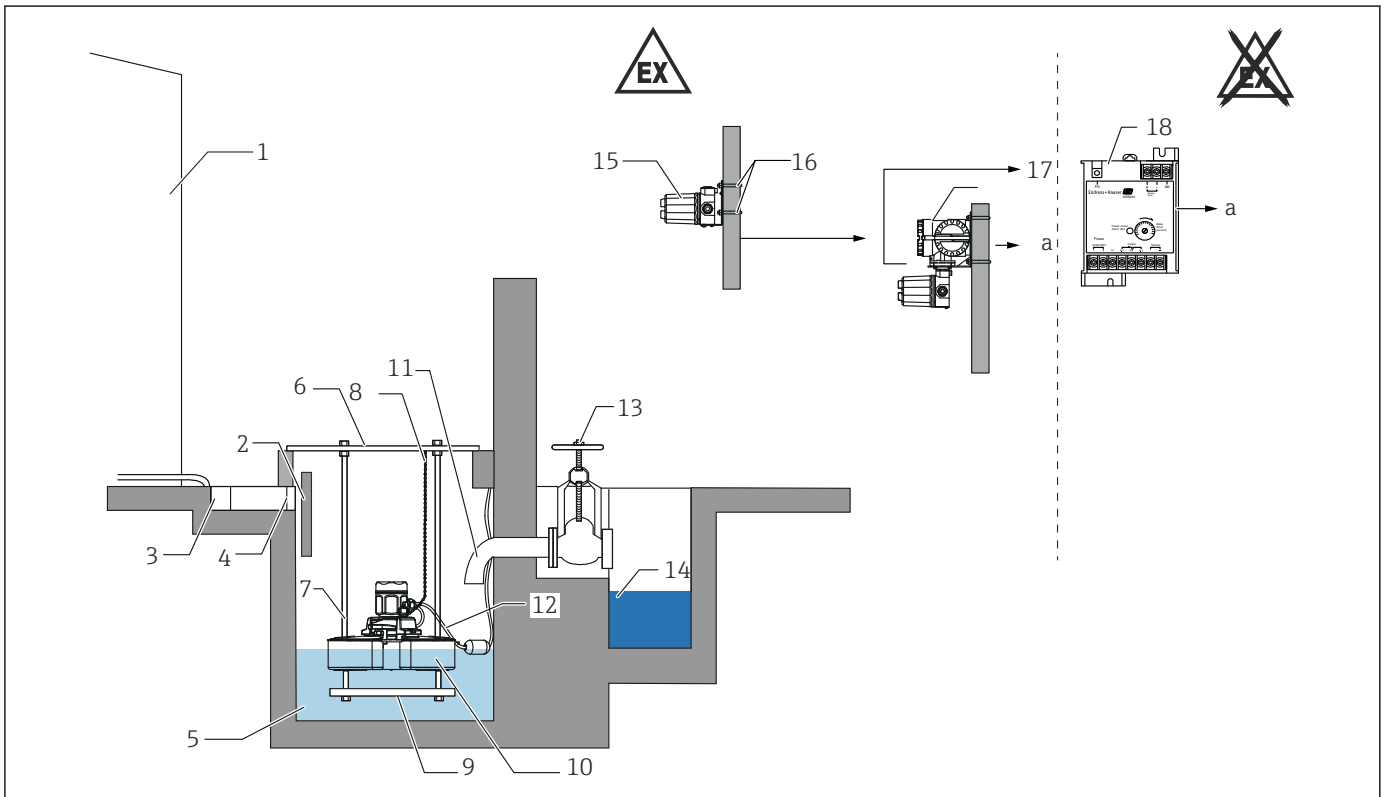

A0039906

8 NAR300 + NRR26x

- a Alarm output
- 1 Tank
- 2 Divider
- 3 U-shaped groove
- 4 Screen
- 5 Pit
- 6 Pit cover
- 7 Float guide
- 8 Chain
- 9 Weight
- 10 Float sensor NAR300
- 11 Discharge nozzle (100 mm (3.94 in) or longer)
- 12 Dedicated cable (included with NAR300)
- 13 Valve
- 14 Drainage groove
- 15 Ex [ia] sensor I/F Ex box
- 16 U-bolt (JIS FF3022 B50)
- 17 NRR261 (Ex d [ia] converter)
- 18 NRR262 (Ex [ia] converter)

i To ground the barrier, either connect it to the tank or use the shielded wire for remote cable. Refer to "Electrical connection" for more information on using the shielded wire for remote cable.

Installation and mounting precautions

1. To prevent snow and debris from entering the pit, installing a waste guard, roof, or other covering is recommended. When snow accumulates on the float sensor, for each 50 g of snow accumulation, the draft line will rise 1 mm (0.04 in), which reduces the float sensor's sensitivity. Mount a covering above the top of the pit inlet to avoid submerging the float sensor housing if the pit water overflows due to heavy rainfall, etc. If water enters the float sensor, it may cause malfunction or failure.
2. If the float sensor becomes off-balanced (tilted by approx. 3 ° or more), it may cause faulty operation or delayed alarm. Use a float guide as much as possible, and also pay attention to the way the cables and chains are laid out.
3. Install a screen at the pit's inlet to remove any debris. If debris or foreign matter clog the sensor unit or inside the pit, it may cause malfunction. Inspect and clean the screen regularly.
4. Attach a chain to the ring on the side of the float sensor head in advance for added convenience. However, each 50 g of increased load on the float will increase the draft by 1 mm (0.04 in), resulting in reduced sensitivity. If using a chain to anchor the float, do not forcibly pull on the chain during inspection.
5. If the pit is completely filled with water, no oil layer will be formed even when oil is leaking. Drain the water as needed so that an oil layer can be formed.
6. Do not forcibly pull or grab and carry the cable as it may cause malfunction or compromised waterproofing.
7. Bend the tip of the discharge nozzle downward by 100 mm (3.94 in) or more when the drain valve is kept open so that an oil layer can be formed. Failure to do so may cause oil to discharge from the pit before it can form a detectable layer on the water surface, resulting in a delayed alarm or detection failure. For pits without a discharge nozzle, such as the one shown in above diagram, install an oil-water separation divider so that an oil layer can be formed.
8. Depending on the liquid flowing into the pit, install a divider to prevent waves, crosscurrents, or liquid from splashing on top of the float.
9. If the pit is too large, divide the pit using an oil separator. Oil leakage cannot be detected unless the volume of oil outflow increases in proportion to the surface area.
10. NAR300, NRR261, and sensor I/F Ex box must be installed at least 50 cm (1.64 ft) apart from each other.

Mounting NAR300 system

Handling precautions

When transporting NAR300, be sure to hold the float with both hands. Avoid holding the parts shown in the diagram below, and do not lift NAR300 by the top of the float sensor. In addition, do not rotate the housing. Doing so may cause device failure.

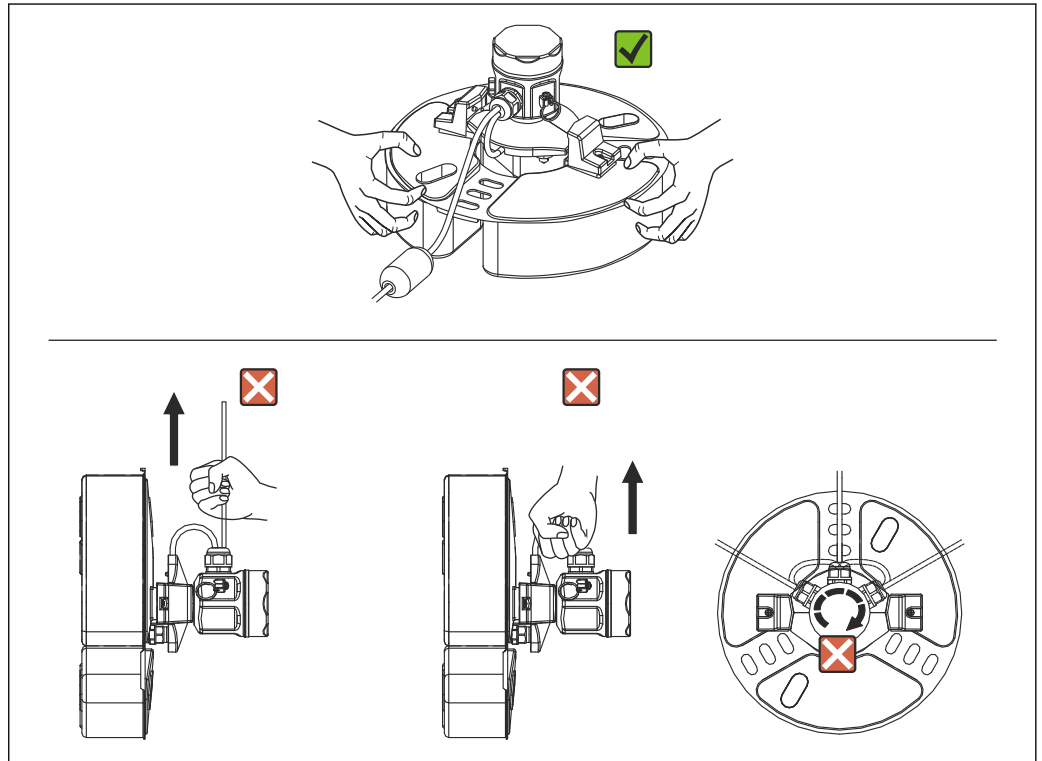

9 Handling NAR300

A0048026

Mounting the float guide

NAR300 can be mounted onto a float guide that has been installed for existing products (CFD10, CFD30, UFD10, NAR291, NAR292).

The float guide is 2 000 mm (78.74 in) in size. If a length shorter than 2 000 mm (78.74 in) is required for use, cut it to size. If a float guide longer than 2 000 mm (78.74 in) is required, contact your Endress+Hauser Sales Center.

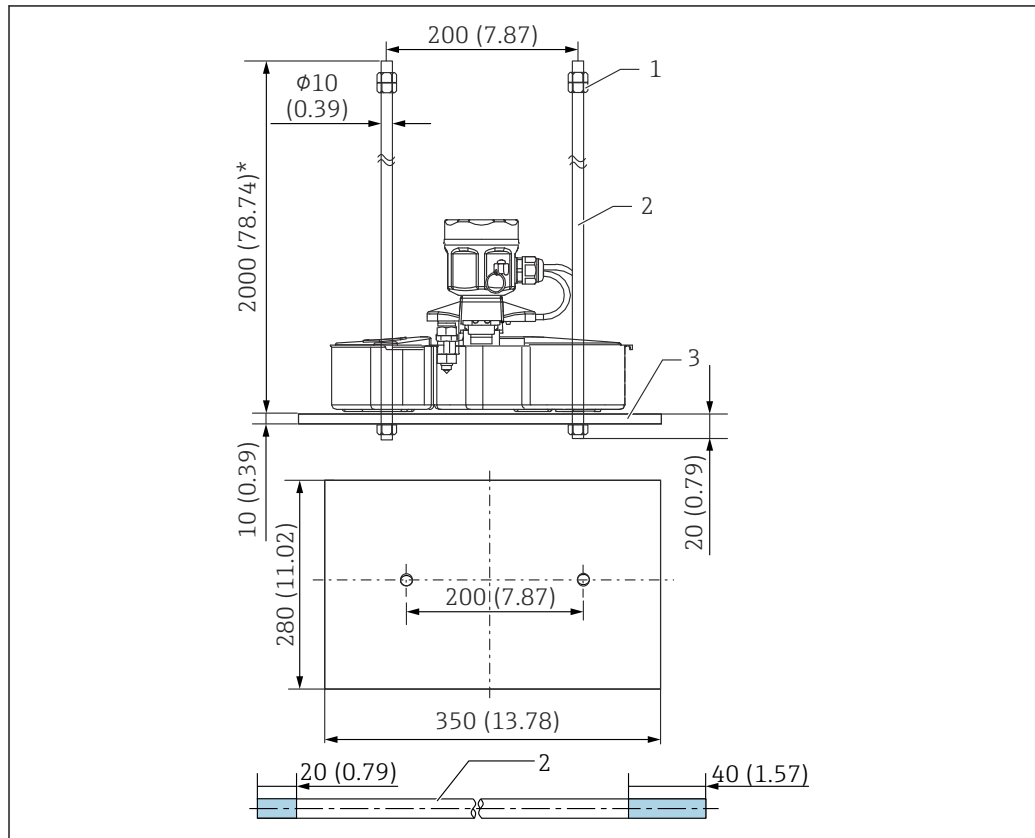

A0039907

10 NAR300, float guide

- 1 Nut (M10)
- 2 Float guide
- 3 Weight

i The 20 mm (0.73 in) and 40 mm (1.57 in) of the float guide in the diagram indicate the lengths of thread grooves.

Environment

Protection class	Item	Description
	Float sensor NAR300	IP67 (outdoor installation)
Ex [ia] sensor I/F Ex box		
Ex d [ia] transmitter NRR261		
	Ex [ia] transmitter NRR262	IP20 (indoor installation)

Process

Float sensor NAR300

Items	Description
Conditions for detected substance	<ul style="list-style-type: none"> ▪ Density 0.7 g/cm³ or higher but less than 1.0 g/cm³ ▪ Floats in water (if the density is 0.9 g/cm³ or higher, then viscosity should be 1 mPa·s or higher. Water ≈ 1 mPa·s) ▪ Water-insoluble ▪ Non-conductive ▪ Liquid ▪ Low affinity to water (a layer of the detected substance must form on the water surface)
Operating temperature	<ul style="list-style-type: none"> ▪ Ambient temperature: -20 to 100 °C (-4 to 212 °F) ▪ Measured liquid temperature: 0 to 100 °C (32 to 212 °F)
Conditions for water in the pit	<ul style="list-style-type: none"> ▪ Density 1.0 g/cm³ or higher but less than 1.13 g/cm³ (however, only when dynamic viscosity is 1 mm²/sec)¹⁾ ▪ Non-freezing ▪ Electric conductivity 10 μS/cm or higher (up to 100 kΩ·cm); however, this should be 1 μS/cm or higher in cases where the float is always floating in the pit water ▪ Cannot be used on the sea surface or places that may be penetrated by seawater
Other	<ul style="list-style-type: none"> ▪ Promptly remove any debris that adheres to the sensor unit ▪ Do not allow mud (or any other dried solid substances) to cake on the float sensor ▪ Avoid installation environments that cause the float sensor to tilt off-balance or change the draft line ▪ Install wave protection walls to avoid cross currents and standing waves of the liquid

- 1) Sensitivity will vary when the specific gravity of water in the bottom layer is different from the factory setting environment, such as when antifreeze is used.

Sensor I/F Ex box / Converter NRR261/NRR262

Items	Description
Connector cable (connection to converter NRR261/NRR262 from sensor I/F Ex box)	<p>Maximum inductance: 2.3 mH, maximum capacitance: 83 nF Reference case: Use of KPEV-S (instrumentation cable)</p> <ul style="list-style-type: none"> ▪ C = 65 nF/km, L = 0.65 mH/km ▪ CW/C = 0.083 μF / 0.065 μF / km = 1.276 km.....1 ▪ LW/L = 2.3 mH / 0.65 mH / km = 3.538 km.....2 ▪ Maximum cable extension: 1.27 km; the maximum cable length is 1 and/or 2, whichever is shorter (round down instead of rounding off)
Operating temperature	Ambient temperature: -20 to 60 °C (-4 to 140 °F)

Mechanical construction

NAR300 system dimensions

Dimensions of NAR300 float sensor

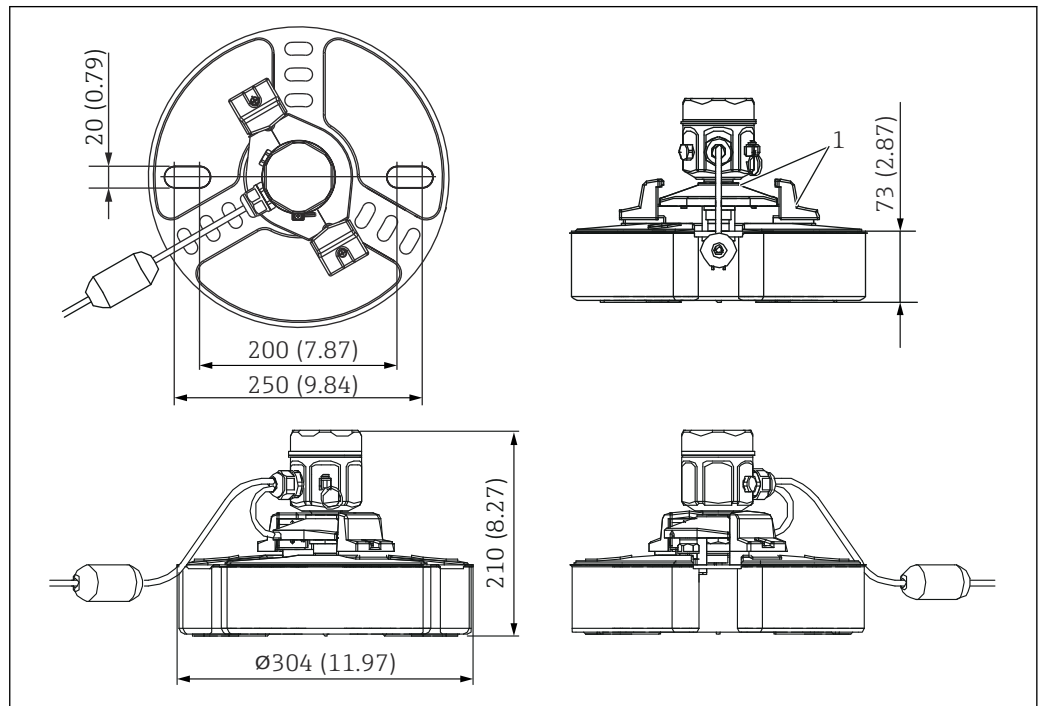

A0039905

11 Outline of float sensor NAR300

1 Float sensor cover

Dimensions of Ex d [ia] transmitter NRR261

Only NRR261 with JPN Ex explosion-proof specifications are delivered with a cable gland (external diameter of compatible cables: $\varphi 12$ to 16 mm (0.47 to 1.02 in)).

Use the order code of Ex d [ia] transmitter NRR261 to specify the electrical conduit connection port.

Normally, Ex d [ia] transmitter NRR261 is mounted on a tank yard's pipe and secured in place with a U-bolt (JIS F 3022 B 50 type). It can also be mounted directly onto wall surfaces (requires 4- $\varphi 12$ mm (0.47 in) holes and M10 securing nuts and bolts (not included in the delivery)).

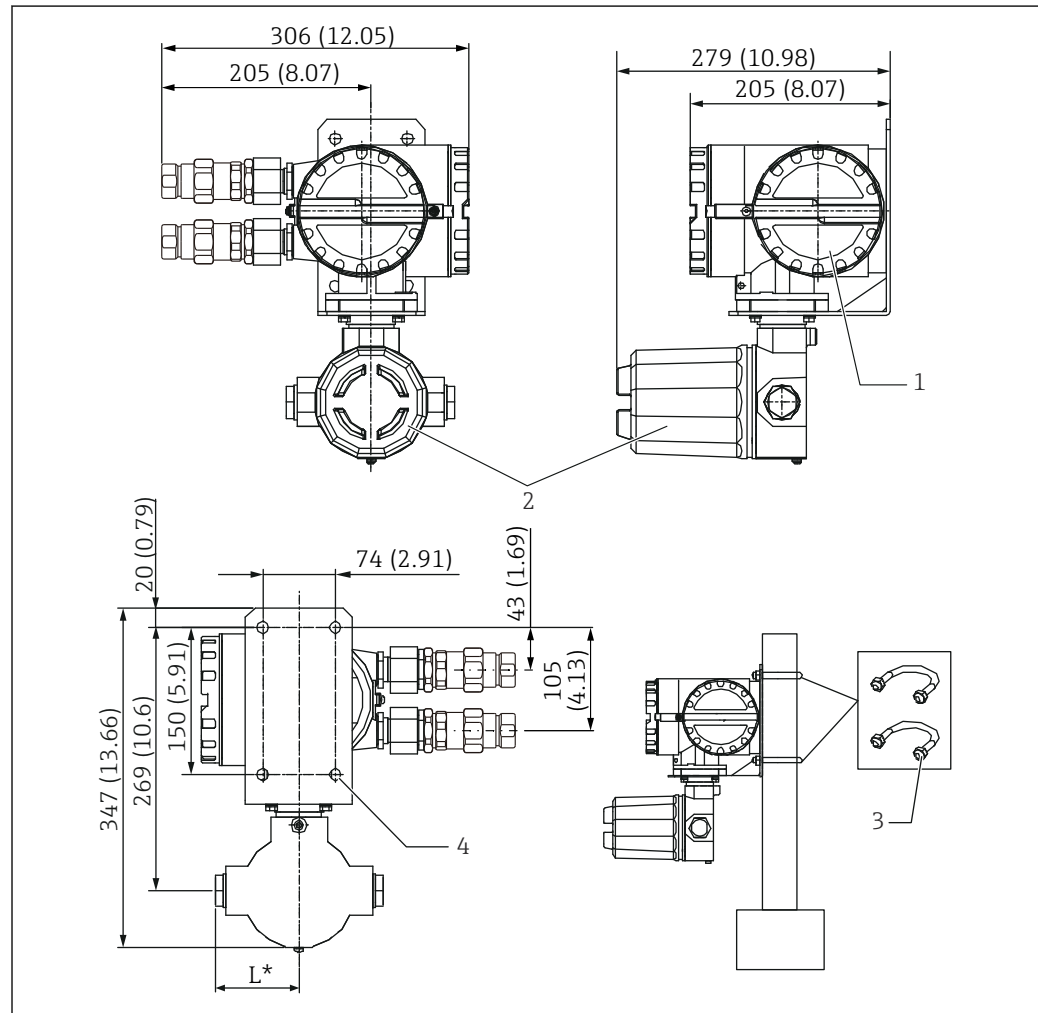

12 Outline of NRR261. Unit of measurement mm (in)

- 1 Ex d side terminal
- 2 Ex [ia] side terminal
- 3 U-bolt (JIS F3022 B50 material: Iron (chromate), 2 nuts and 2 flat washers included)
- 4 4- $\varphi 12$ holes
- L G1/2: 85 mm (3.35 in), NPT1/2: 97 mm (3.82 in), M20: 107 mm (4.21 in)

Dimensions of Ex [ia] transmitter NRR262

NRR262 is installed indoors, such as in instrument rooms, and it can be mounted easily with two M4 screws. In addition, "one-touch" snap-in mounting is possible using a DIN rail EN50022 (not included in the delivery). This rail-mounted method is beneficial in cases where multiple transmitters are mounted in series, and in cases where installation of additional transmitters is expected in the future.

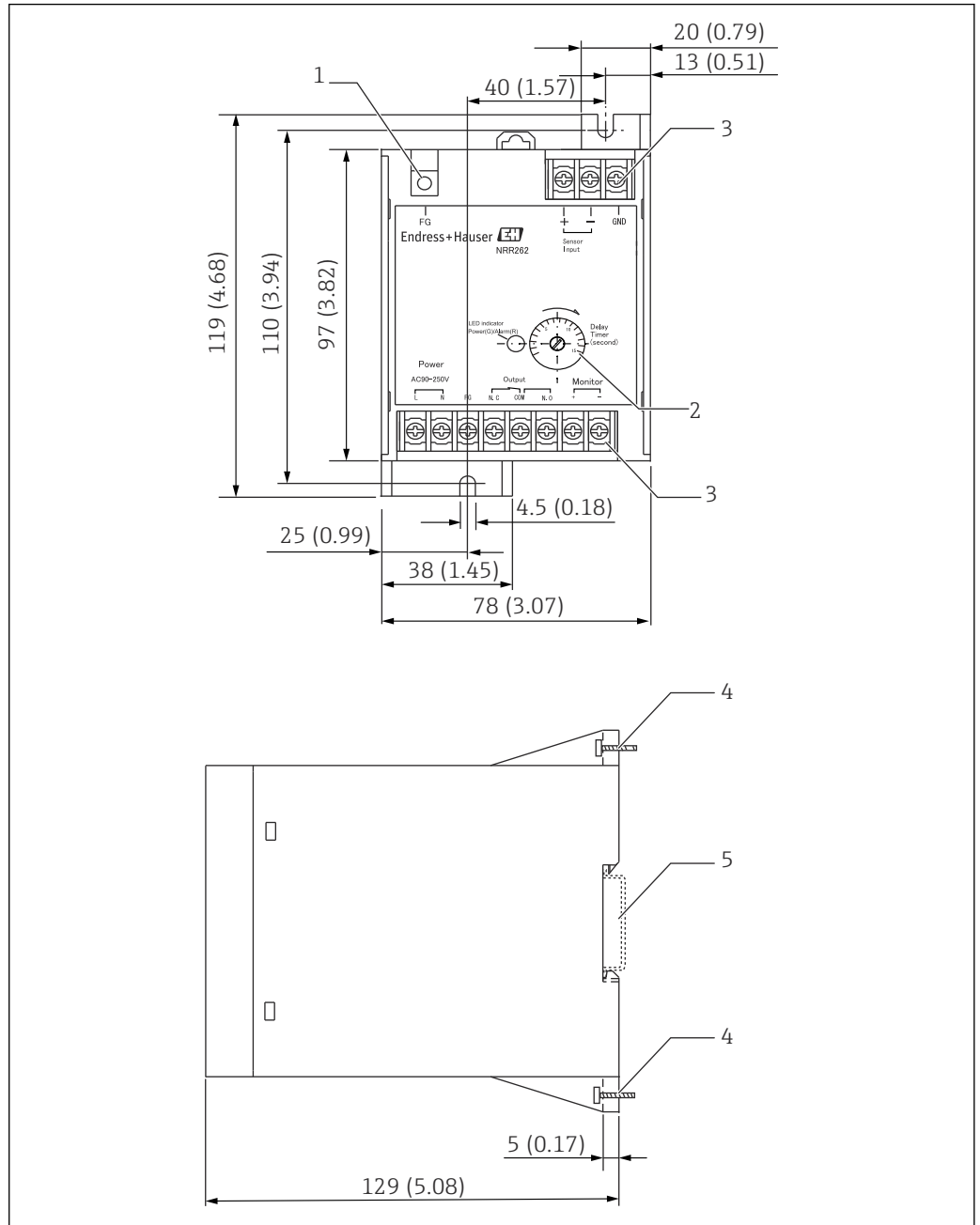

13 Outline of NRR262. Unit of measurement mm (in)

- 1 Thread (M4) for protective grounding
- 2 Delay trimmer
- 3 Thread (M3)
- 4 Screw (M4)
- 5 DIN rail: EN50022 compliant

Dimensions of Ex [ia] sensor I/F Ex box

The Ex [ia] sensor I/F Ex box is used in combination with Ex d [ia] transmitter NRR261 or Ex [ia] transmitter NRR262 in order to convert signals from the float sensor into electric current signals. Normally, it is mounted on a tank yard's pipe and secured in place with a U-bolt (JIS F 3022 B 50 type). It can also be mounted directly onto wall surfaces (requires 4-φ12 mm (0.47 in) holes and M10 securing nuts and bolts (not included in the delivery)).

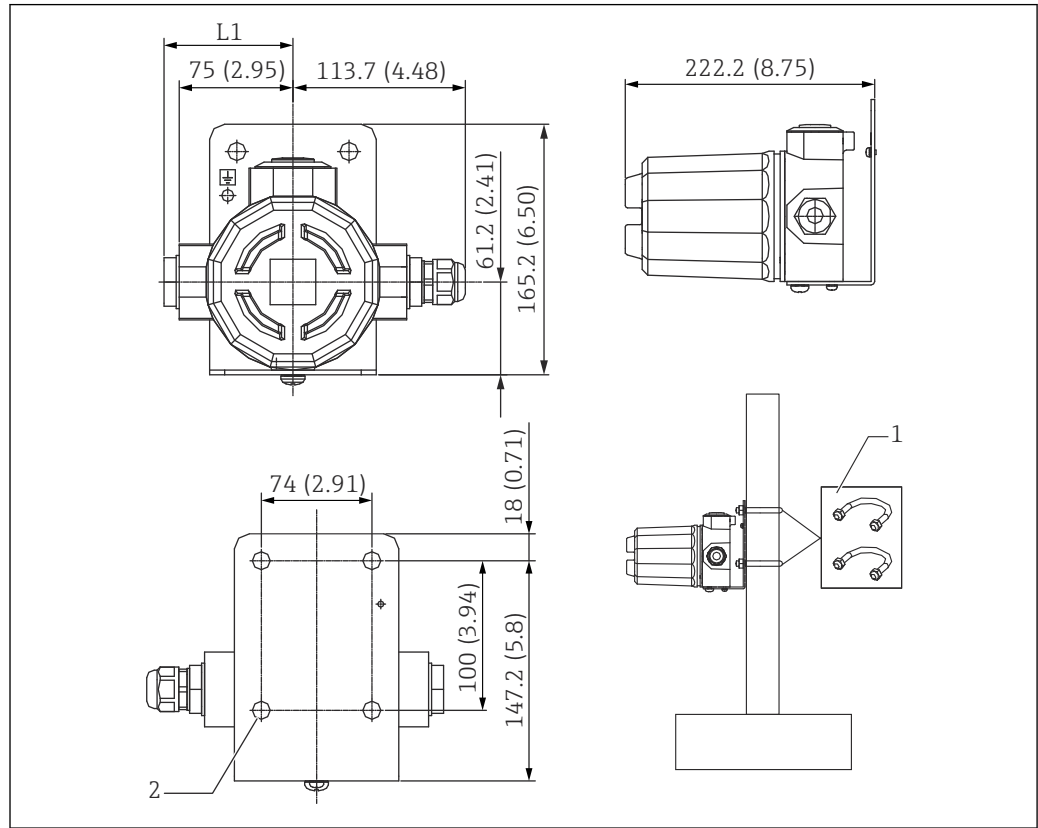

14 Outline of Ex [ia] sensor I/F Ex box. Unit of measurement mm (in)

- L1 G1/2 / NPT1/2: 85 mm (3.35 in), M25: 107 mm (4.21 in)
- 1 U-bolt (JIS F3022 B50 material: Iron (chromate), 2 nuts and 2 flat washers included)
- 2 4-φ12 mm (0.47 in) holes

i Use the order code of float sensor NAR300 to specify the conduit connection port.

Weight of the NAR300 system

Float sensor NAR300	Approx. 2.5 kg (5.51 lb) (including the dedicated shielded cable (PVC) 6 m (19.69 ft))
Ex [ia] sensor I/F Ex box	Approx. 3.2 kg (7.05 lb)
Ex d [ia] transmitter NRR261	Approx. 10 kg (22.05 lb)
Ex [ia] transmitter NRR262	Approx. 0.6 kg (1.32 lb)

Detection sensitivity

Float sensor NAR300	Water-filled pit: Set to 10 (0.39) ± 1 mm (0.04 in) with kerosene at the time of shipment from the factory
---------------------	--

Materials

Wetted material	<ul style="list-style-type: none"> ▪ Float: SUS316L ▪ Conductive sensor: SUS316+PTFE
Non-wetted parts: Ex [ia] sensor I/F Ex box	Housing/cover: Aluminum casting

Ex d [ia] transmitter NRR261	Housing/cover: Aluminum casting
Ex [ia] transmitter NRR262	Housing: Plastic

Certificates and approvals

CE mark The measuring system meets the legal requirements of the applicable EC guidelines. These are listed in the corresponding "EC Declaration of Conformity" along with the standards applied. Endress +Hauser confirms successful testing of the device by affixing to it the CE mark.

Ex approval The NAR300 system has the following four certificates and qualifications:

- ATEX certificate: FM.14ATEX0048X
- IECEx certificate: IECEx FMG 14.0024X
- FM certificate: 3049525
- JPN Ex qualification: CML 18JPN8362X

 TIIS and JPN Ex devices cannot be mixed.

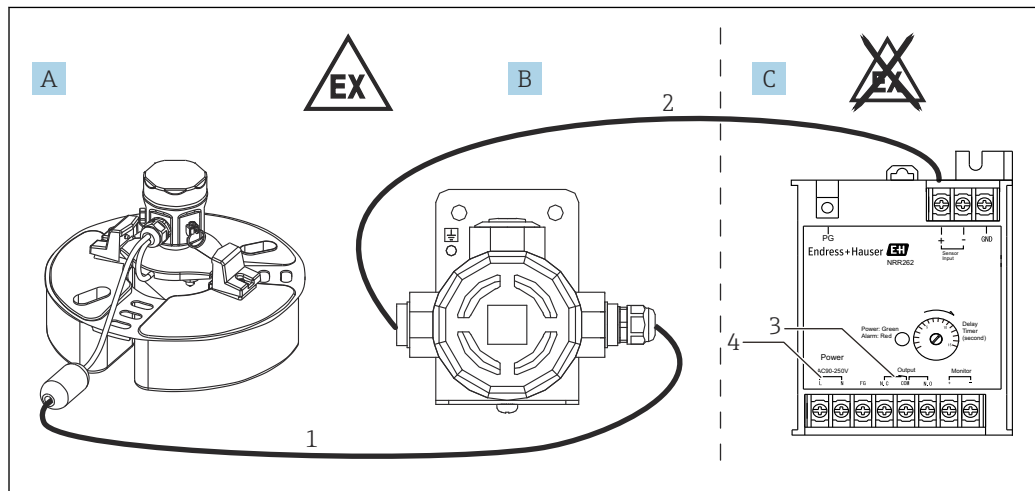

A0039921

 15 System configuration 1

- A Float sensor NAR300-x6xxxx
 B Sensor I/F Ex box
 C Ex [ia] transmitter NRR262
 1 Ex [ia] dedicated connection cable (6 to 30 m (19.69 to 98.43 ft))
 2 Cable for sensor I/F Ex box and transmitter (refer to Process conditions)
 3 Alarm output: Alarm/PLC/DCS, etc.
 4 Power supply (AC/DC)

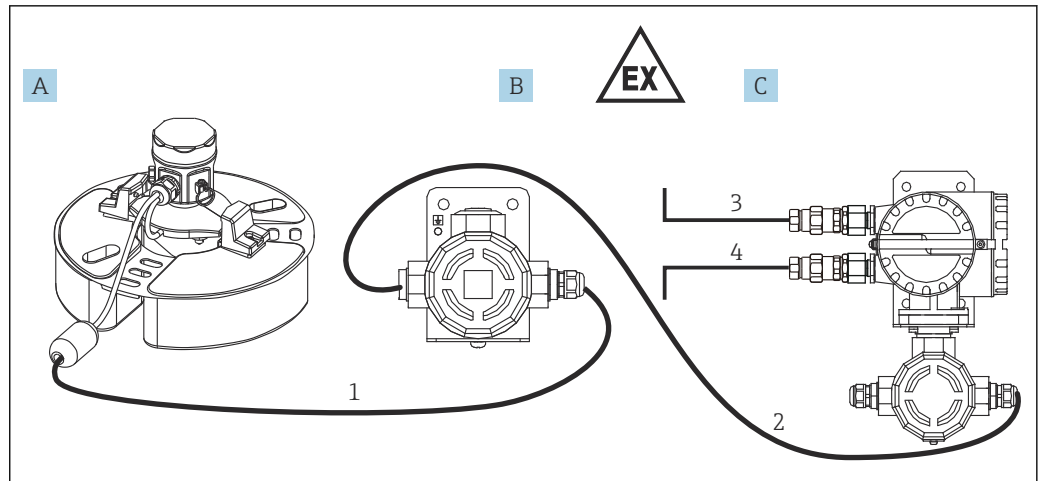

A0039922

16 System configuration 2

A Float sensor NAR300-x6xxxx

B Sensor I/F Ex box

C Ex d [ia] transmitter NRR261 (separate type)

1 Ex [ia]-dedicated connection cable (6 to 30 m (19.69 to 98.43 ft))

2 Cable for sensor I/F Ex box and transmitter (refer to Process conditions)

3 Alarm output: Alarm/PLC/DCS, etc.

4 Power supply (AC/DC)

Functional safety
certification

SIL2 IEC61508 (ATEX, IECEx, FM, JPN Ex)

Order information

Detailed ordering information is available from the following sources:

- In the Product Configurator on the Endress+Hauser website: www.endress.com -> Click "Corporate" -> Select your country -> Click "Products" -> Select the product using the filters and search field -> Open product page -> The "Configure" button to the right of the product image opens the Product Configurator.
- From your nearest Endress+Hauser sales organization: www.addresses.endress.com



Product Configurator - the tool for individual product configuration

- Up-to-the-minute configuration data
- Depending on the device: Direct input of measuring point-specific information such as measuring range or operating language
- Automatic verification of exclusion criteria
- Automatic creation of the order code and its breakdown in PDF or Excel output format
- Ability to order directly in the Endress+Hauser Online Shop

Accessories

Float guide

If you have ordered a system with a float guide, construct a leveled weight so that the float sensor can land horizontally after debris and stones have been removed.

The float guide is 2 000 mm (78.74 in) in size. If a length shorter than 2 000 mm (78.74 in) is required for use, cut it to size. If a float guide longer than 2 000 mm (78.74 in) is required, contact your Endress+Hauser Sales Center.

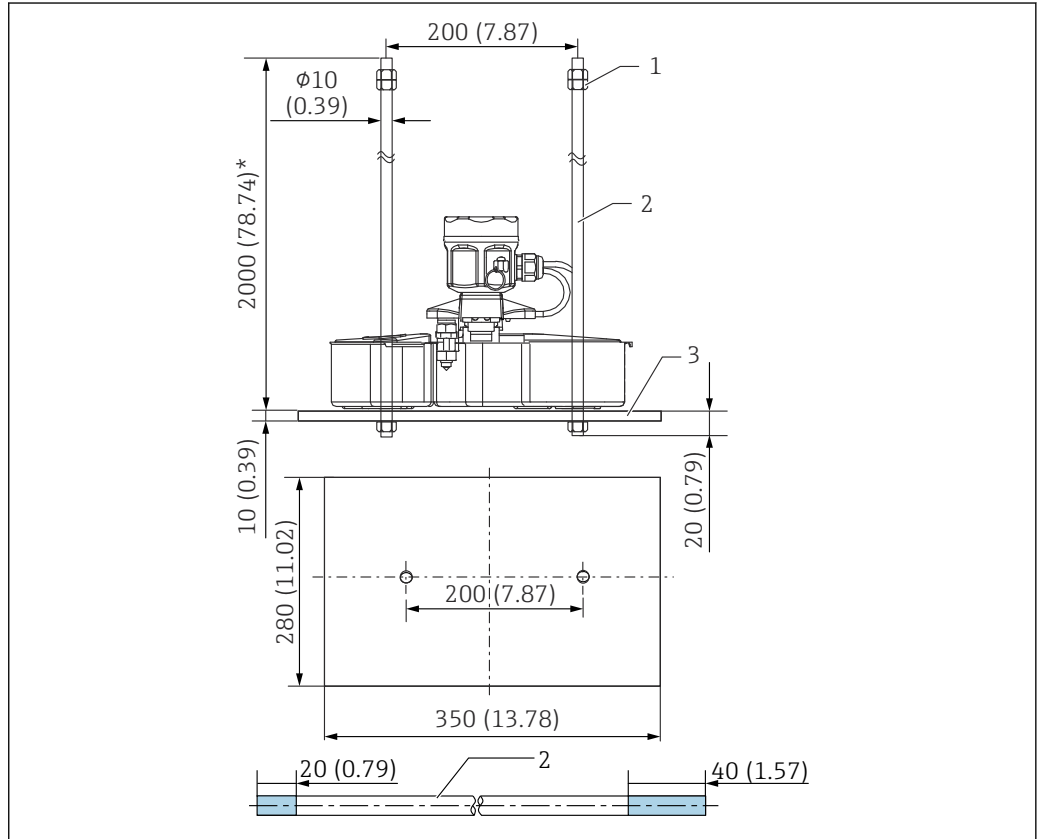

A0039907

17 Float guide

- 1 Nut (M10)
- 2 Float guide
- 3 Weight

Name	Delivered quantity	Materials
Float guide	2	SUS304
Weight	1	Different options are available from SS400 or SUS304
Nut (M10)	6	SUS304

i The 20 mm (0.73 in) and 40 mm (1.57 in) of the float guide in the diagram indicate the lengths of thread grooves.

**U-bolt / cable gland
(waterproof connection for
JPNEx)**

U-bolt (JIS F3022 B50) is used when mounting the converter. Have a pipe with an internal diameter of 50A (2B ϕ 60.5 mm (198.5 in)) ready. Tighten and secure the cable gland after inserting the cable from NAR300.

i The pressure-resistant packing cable gland is supplied for the JPN Ex specification only. Always use this cable gland.

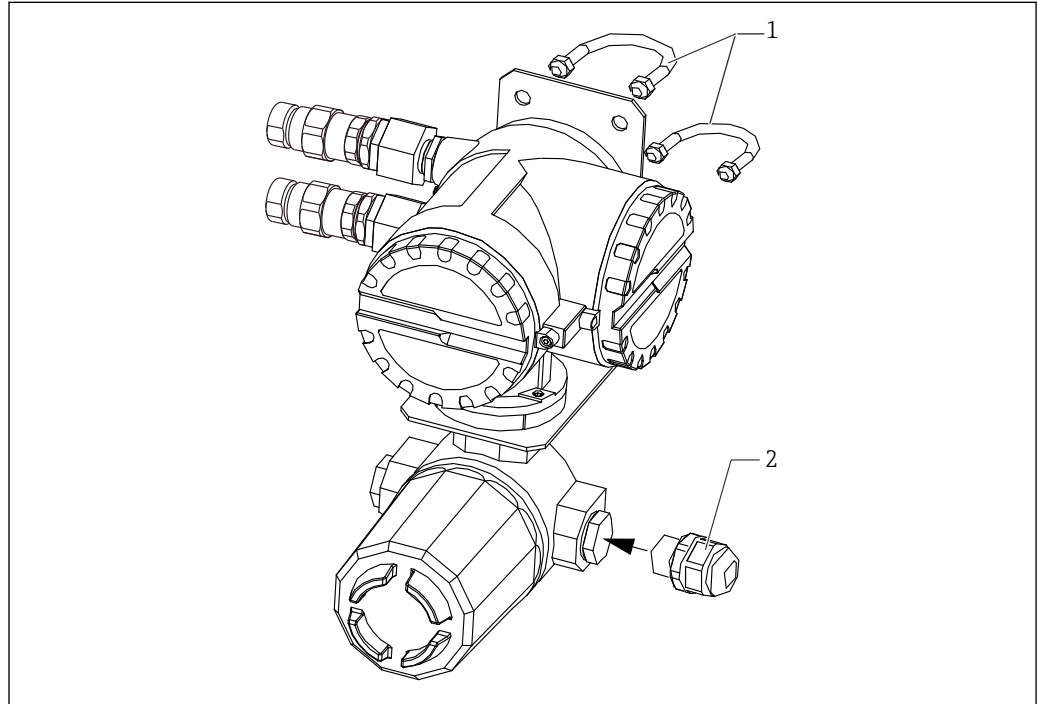

A0039892

18 U-bolt / cable gland

1 U-bolt (JIS FF3022 B50)

2 Cable gland (waterproof connection)

Name		Delivered quantity	Materials
U-bolt		2	Iron (chromate)
U-bolt accessory	Nut	4	
	Flat washer	4	
Cable gland (waterproof connection)		1	Nylon





71661260

www.addresses.endress.com
