

Technical Information

Soliwave FDR57, FQR57

Microwave barrier

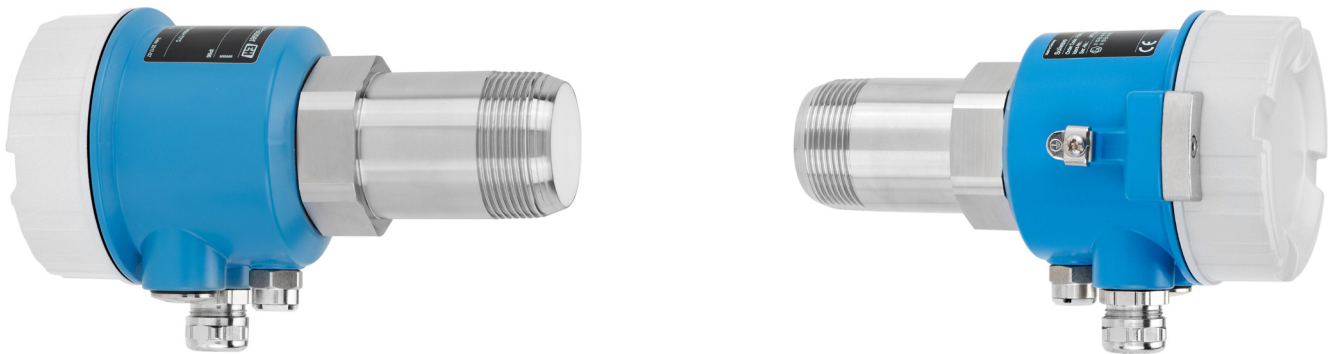

Microwave barrier for non-contact level limit detection and bulk flow detection

Application

- Non-contact detection procedure
- Suitable as a level limit switch for bulk solids of all kinds and for liquids, as well as for monitoring and counting piece goods
- Analysis of accumulations, fouling or similar
- Optional monitoring of bulk flow (movement/no movement)

Device properties

- Detection range up to 100 m (level limit detection) or 10 m (bulk flow detection) depending on the bulk solids
- Process temperatures up to +70°C (+158°F) or +450°C (+842°F) with optional high temperature adapter for temperature reduction
- Process pressure up to 680 kPa (6.8 bar) absolute or 2.1 MPa (21 bar) absolute with optional high pressure adapter
- Also suitable for use under strong continuous vibration load.
- For use in hazardous areas (dust and gas)

Your benefits

- Simple mounting with thread R 1½, 1½ NPT or G 1½ (with counter nut)
- Electronics housing can be rotated by 360°, allowing orientation into optimum position after installation
- High mechanical robustness, therefore no wear, long operating life and maintenance-free
- No separate supply voltage required (power supplied via the Nivotester FTR525)
- Fully mechanically compatible with devices of the Soliwave microwave barrier FQR50/FDR50 and FQR56/FDR56
- Increased reliability of level limit monitoring through optional integrated bulk flow detection
- Measuring principle almost independent of process properties
- Can also be used in difficult applications, where other measurement methods fail
- Simple operation via the FTR525 Nivotester with graphical display saves time and reduces costs

Table of contents

Document information	3	Process	21
Display conventions	3	Process temperature range	21
Function and system design	4	Process pressure range	21
Measuring principle	4	Vibration	21
Measuring system	6	Mechanical construction	22
Safety	6	Dimensions	22
Input	6	Weight	22
Measured variable	6	Materials	23
Measuring range	7	Process connections	23
Operating frequency	7	Operability	23
Transmission power	7	Operation	23
Antenna opening angle	7	Display elements	23
Detectable speed of bulk flow	7	Certificates and approvals	23
Output	7	CE mark	23
Output signal	7	RoHS	23
Power supply	7	Ex approval	24
Terminal assignment	7	Radio approval	24
Supply voltage	7	External standards and guidelines	24
Potential matching	8	Ordering information	24
Terminals	8	Scope of delivery	24
Cable entries	8	Accessories	24
Connector	8	Plug connector	25
Cable specification	8	Pre-terminated connecting cable	25
Performance characteristics	8	Mounting bracket	25
Reference operating conditions	8	Mounting flange	25
Influence of ambient temperature	8	Weld-in or screw-in adapter	27
Influences on level limit detection	9	High pressure adapter	27
Influences on bulk flow detection	9	Plug	28
Vibration effects	9	Sight glass fitting	28
Installation	9	Insertion adapter	30
Mounting location	9	Weld-in nozzles	31
Mounting position	10	Spacer tube	31
Orientation	10	Wave guide	32
Optimization of the signal quality	10	High temperature adapter with length extensions	33
Operation with reflector(s)	11	Weather protective cover	33
Parallel mode	11	Supplementary documentation	34
Installation instructions	11	Standard documentation	34
Assembly in contact with the process	12	Device-dependent supplementary documentation	34
Installation examples	13		
Mounting without contact with the process	14		
Connecting cable length	20		
Connecting cable	20		
Environment	21		
Operating temperature range	21		
Storage temperature	21		
Degree of protection	21		
Vibration resistance	21		
Electromagnetic Compatibility (EMC)	21		

Document information

Display conventions

Safety symbols

NOTICE

This symbol contains information on procedures and other facts which do not result in personal injury.

Symbols for certain types of information

 Permitted

Indicates procedures, processes or actions that are allowed.

 Forbidden

Indicates procedures, processes or actions that are forbidden.

 Tip

Indicates additional information.

 Reference to documentation

 Reference to page

 Reference to graphic

 1., 2., 3. Series of steps

Symbols in graphics

A, B, C ... View

1, 2, 3 ... Item numbers

Device-specific symbols

 Free path

Indicates a free path (level limit detection)

 Covered path

Indicates a covered path (level limit detection)

 Minimum bulk flow

Indicates a minimum or absent bulk flow (bulk flow monitoring)

 Maximum bulk flow

Indicates a maximum bulk flow (bulk flow monitoring)

Function and system design

Measuring principle

Level limit detection

The FQR57 transmitter emits a microwave signal, which is detected by the FDR57 transceiver directly opposite, which then sends the corresponding serial output signal to the FTR525 Nivotester.

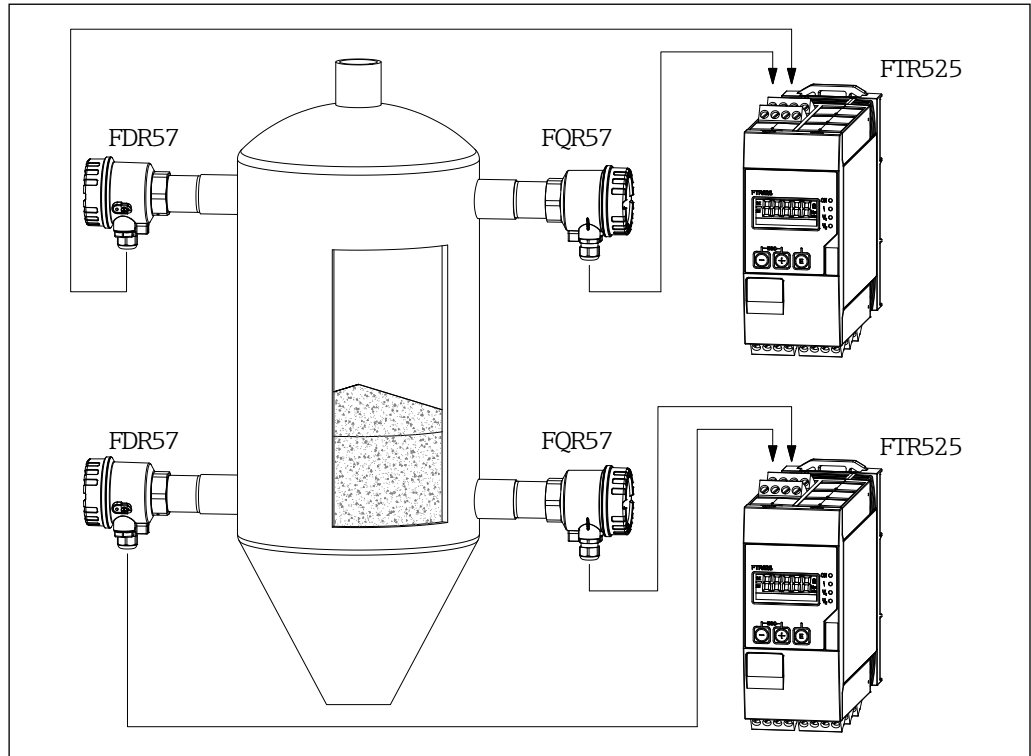

1 Example of level limit detection

000000096

The microwave barrier is typically used for notification when containers, silos or similar are full and/or empty. Full notification is used to protect against overflow while empty notification is used, for example, to protect downstream conveyor devices from running dry.

With the help of the analog output (current 4 to 20 mA), fouling and accumulations can be detected; an increase in the fouling of a filter is, for example, indicated by a falling current value.

Optional integrated bulk flow detection

The FDR57 transceiver also emits a signal, which is reflected by the moving bulk solids. It measures the strength of the reflected frequency-shifted energy (Doppler effect) and sends the corresponding serial output signal to the FTR525 Nivotester.

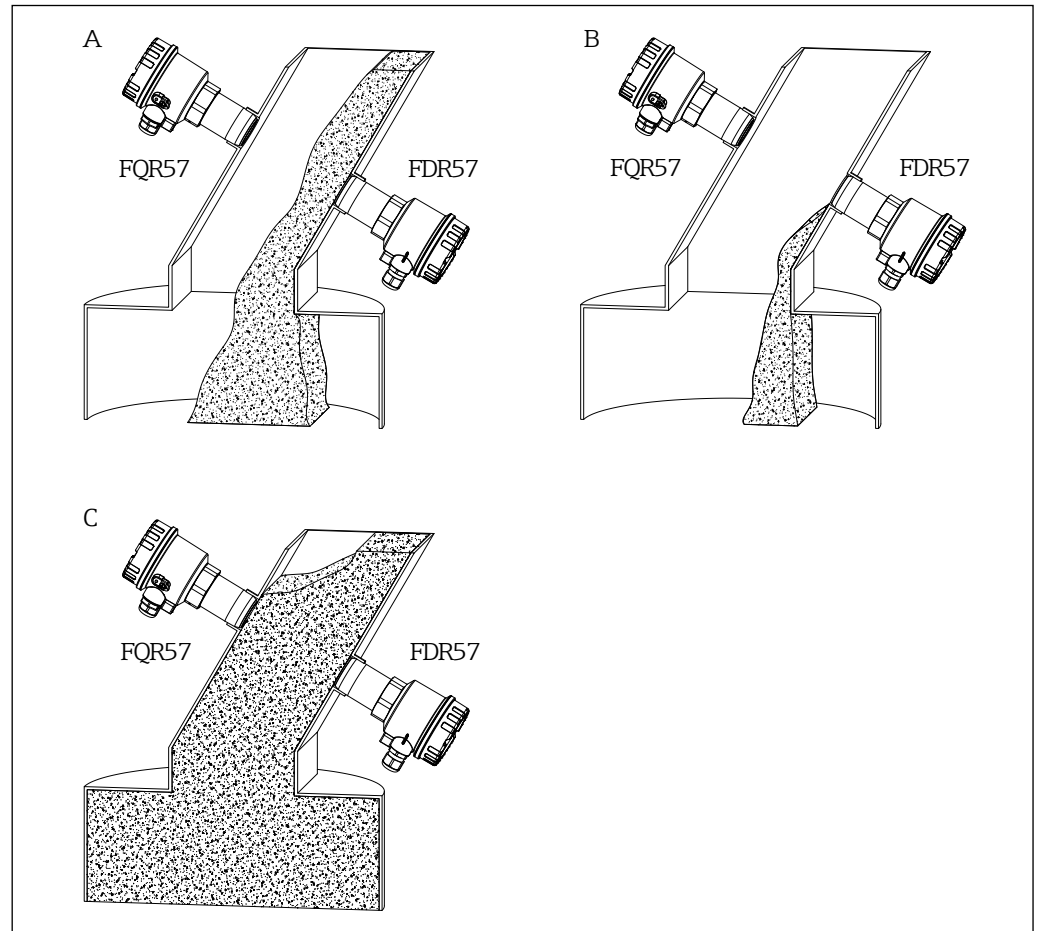

000000090

2 Example bulk flow detection

Item	Status	Level limit	Bulk flow
A	Continuous bulk flow		
B	Bulk flow torn-off		
C	Backlog		

NOTICE

- As only the FDR57 transceiver detects the bulk flow, it should be mounted as close as possible to the bulk flow.
- If the detection range is under 500 mm, the FDR57 and FQR57 should be installed at an angle of 90° relative to one another, to avoid possible overrangings and therefore faulty measurements (LINK auf Bild).

Application example: backlog monitoring

Microwave barriers with integrated bulk flow detection are typically used to monitor shafts, feed hoppers or similar with regard to material flow and backlogs.

Previously, two microwave barriers were required for this. The first to monitor continuous material transport by means of the continuous attenuation of the microwave signal. The second, which must be installed above the material flow, to detect the backlog by means of a sudden increase in the attenuation of the microwave signal.

The Soliwave microwave barrier with integrated bulk flow detection now performs both these tasks. The FDR57 transceiver now detects the continuous material transport. In combination with the signal from the microwave barrier, it is possible to detect whether the material flow is interrupted or if there is a backlog.

NOTICE

- The range of the microwave signal is influenced by the different types of materials. The attenuation is dependent on the electrical properties of the damping material. Materials with the capacity to conduct electricity, such as metals, reflect the waves, while other materials with lower conductivity only weaken them or are even penetrated.
- The attenuation of the microwaves is reduced as the damping of the material to be permeated becomes lower.

Measuring system

The complete system consists of the FDR57/FQR57 devices of the Soliwave microwave barrier as well as the Nivotester FTR525 remote process transmitter with control unit.

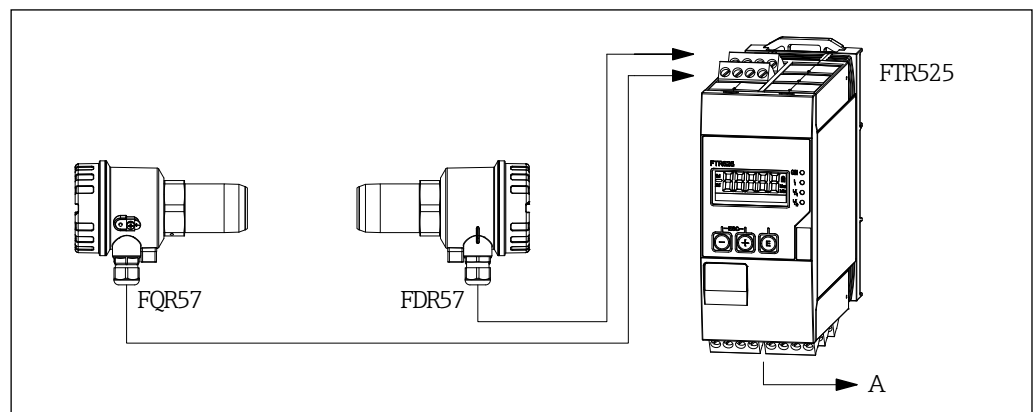

3 Overview of the complete measuring system

000000081

A Power supply and signal outputs

i For details of the extensive functions of the Nivotester FTR525, please see the separate Technical Information (→ 34).

NOTICE

For optimal installation in the process, the FDR57 and FQR57 devices of the microwave barrier can be extended with corresponding accessories such as weld-in nozzles, sight glasses or high temperature adapters for process separation (→ 24).

Safety

We shall only grant a guarantee if the device is installed and operated in accordance with the Operating Instructions. Safety measures in accordance with the user's safety standard, which provide additional protection for the device and its signal transfer, are to be implemented by the user.

Input**Measured variable**

- Level limit detection: Absorption of the electromagnetic waves emitted by the FQR57 transmitter
- Bulk flow detection: Doppler frequency

Measuring range	<ul style="list-style-type: none"> ▪ Max. 100 m (level limit detection) ▪ Max. 10 m (bulk flow detection) depending on the bulk solids
Operating frequency	24 GHz ISM
Transmission power	<p>The power produced by the FDR57 and the FQR57 is maximum 100 mW e.i.r.p. (equivalent isotrope radiation performance).</p> <ul style="list-style-type: none"> ▪ Power density directly in front of the device: Approx. 1 mW/cm² ▪ Power density at a distance of 1 m: Approx. 0.3 μW/cm² <p>i The power density is clearly below the recommended limit values of the ICNIRP guidelines "Guidelines for Limiting Exposure to Time-Varying Electric, Magnetic, and Electromagnetic Fields (up to 300 GHz)" and thus is completely harmless for humans.</p>
Antenna opening angle	Approx. ±9°
Detectable speed of bulk flow	0.3 ... 31 m/s

Output

Output signal	<p>Serial signal for the FTR525 Nivotester</p> <p>i For details on the extensive output signals of the FTR525 Nivotester (4 to 20 mA, max. two relays or SSR, open collector), please see the separate technical information (→ 34).</p>
----------------------	---

Power supply

Terminal assignment

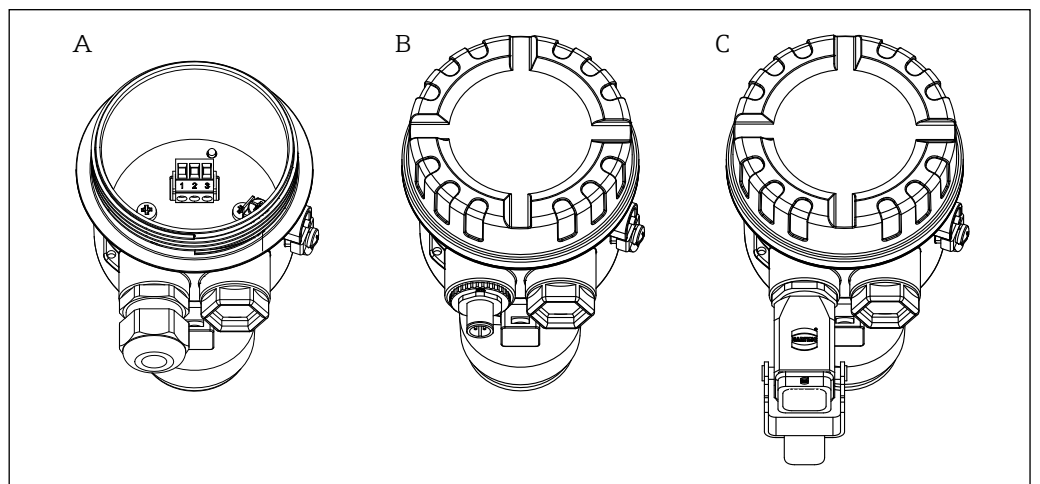



4 Terminal assignment

- A Connection terminals
 B Connector M12 Binder series 713/763
 C Connector Harting HAN8D

i For details on the FTR525 Nivotester wiring, please see the separate Technical Information (→ 34).

Supply voltage	The supply voltage is provided by the FTR525 Nivotester.
-----------------------	--

 For details on the power supply to the FTR525 Nivotester, please see the separate Technical Information (→ 34).

Potential matching

Requirements:

- The potential equalization should be connected to the outer ground terminal of the FDR57 and FQR57.
- For optimum electromagnetic compatibility, the potential matching line should be as short as possible.
- The recommended minimum cable cross-section is 2.5 mm².
- Potential equalization of the FDR57 and FQR57 should be incorporated in the local potential equalization.



For devices intended for use in hazardous locations, please observe the guidelines in the Ex documentation (XA).

Terminals

Max. 2.5 mm²

Cable entries

- Cable gland M20 x 1.5 or cable entry ½ NPT
- Degree of protection: Min. IP66
- Cable gland in non-hazardous areas:
 - Material: Plastic
 - Color: Gray
 - Clamping range: 5 to 10 mm (EN 61444) or 7-10 mm (UL-514 B)
- Cable gland in hazardous areas:
 - Material: Nickel-plated brass
 - Color: Silver
 - Clamping range: 7 to 10.5 mm
- Quantity: 1 piece per device
- The cable gland is only admissible for the connection of fixed-installation lines and cables. The operator must ensure corresponding strain relief.

Connector

- M12 round plug connector Binder series 713/763
 - 4-pin
 - Housing made of die-cast zinc, nickel-plated
- Harting plug-in connector
 - Connector insert Han® 8 D, 3-pin
 - Harting Han® 3 A housing, die-cast zinc, powder-coated RAL 7037 (gray)



- The connector is internally connected with the terminal by a wire.
- Suitable connectors (with and without pre-terminated connecting cable) are available as accessories (→ 25).

Cable specification

- Normal instrument cable (min. 3-wire) is sufficient
- Connecting cable length (LINK)
- Cable resistance: max. 12 Ω/km
- Minimum requirement: Cable temperature range = ambient temperature

Performance characteristics

Reference operating conditions

Every application is different in terms of its shape and size (such as detection area and influential reflexion edges), distance from FDR57 and FQR57 to the medium as well as the properties of the medium (such as attenuation and moisture levels) and therefore always requires an individual basic setup of the microwave barrier.

Influence of ambient temperature

The ambient temperature has no direct influence on the measuring system (FDR57 and FQR57 are temperature-compensated internally).

Influences on level limit detection

The influences of the shape and size, distances of FDR57 and FQR57 from the medium and the medium properties are eliminated during a basic setup.

The following points, however, have an influence on level limit detection:

- **Moisture within the process**

In principle, additional moisture (for example, condensate running down the radiation window of the FDR57 and FQR57) attenuates the measuring signal. To the extent that there are variable moisture levels, the microwave barrier must be adjusted under the least favourable conditions, so that the "Free path" and "Covered path" statuses can be detected reliably.

- **Accumulations**

Accumulations in front of the radiation window of the FDR57 and FQR57 can also lead to attenuation of the measuring signal (potentially further amplified by additional moisture). Accumulations must therefore be avoided through structural measures or the use of special process adapters (accessories → )24), or must be removed during regular maintenance measures (depending on the degree of influence).



- When exchanging the devices, they do not have to be adapted to the application again. The application-dependent configuration is automatically transferred from the FTR525 Nivotester to the devices when it is connected.
- With the help of the current output from the FTR525 Nivotester, the progress of accumulations, fouling or similar from "unsoiled" to "soiled" can be evaluated (limit values are individually configurable).

Influences on bulk flow detection

In addition to the influences on level limit detection, the following points must also be observed for the bulk flow detection:

- **Distance of FDR57 from the medium**

The measuring signal is influenced by the distance between the FDR57 and the medium. With significantly deviating distances, the FDR57 should be installed, if possible, such that the distance is as constant as possible. If this is not possible, the microwave barrier must be adjusted under the least favourable conditions in this case too.



- If the detection range is under 500 mm, the FQR57 and FDR57 should be installed at an angle of 90 ° relative to one another, to avoid possible overrangings and therefore faulty measurements (→ 10 „Notes on orientation“).

Vibration effects**Vibration resistance - Sine vibration test according to EN 60068-2-6:**

- Excitation mode: Sine
- Frequency range: 5 to 500 Hz
- Amplitude: 5 to 15 Hz (5.5 mm) peak / 15 to 500 Hz 5 g
- Throughput speed: 1 octave per minute
- Test directions: 3 directions (X, Y, Z)
- Test duration: approx 140 min per direction
- Test temperaturw: -20 to +70 °C (-4 to +158 °F)

Vibration resistance - Mechanical shock according to EN 60068-2-27:

- Excitation mode: Shock half - sine
- Shock duration: 18 ms
- Amplitude: 30 g
- No. of shocks: 3 per direction and temperature
- Test directions: 6 directions in space ($\pm X$, $\pm Y$, $\pm Z$)
- Shock temperature: -20 to +70 °C (-4 to +158 °F)

Installation

Mounting location

The mounting location must be selected such that application-specific influences are minimized (see "Performance characteristics").

NOTICE

- Mechanical protection of the devices (such as protection against larger falling product pieces) should also be taken into account.
- Depending on the installation locations, different process adapters are available as accessories (→ 24).

 For devices intended for use in hazardous locations, please observe the guidelines in the Ex documentation (XA).

Mounting position

In principle, the installation position can be any for the microwave barrier, but the FDR57 and FQR57 must be opposite each other within the detection range (maximum angle between both devices (antenna opening angle) = 9°).

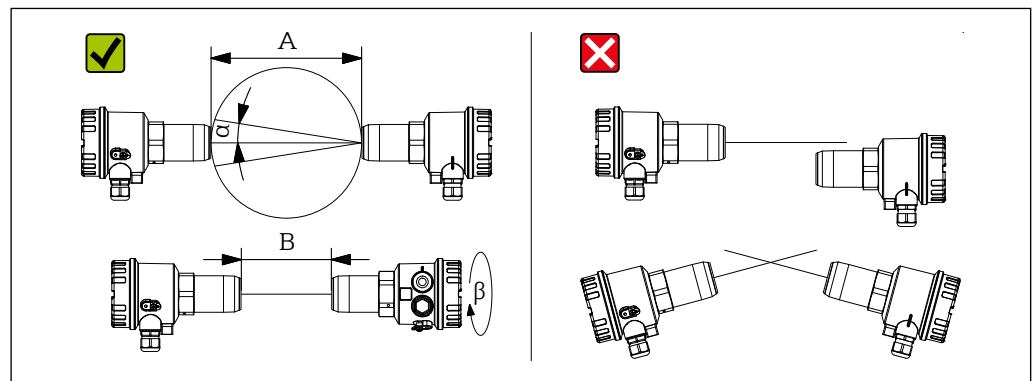

 5 Notes on orientation

- A Detection range 0.5 to 100 m
 B Detection range 0.03 to 0.5 m
 α Antenna opening angle approx. 9°
 β 90°

000000094

Orientation

- As the microwaves are polarised, the FDR57 and the FQR57 must not be turned towards each other by their longitudinal axis (except by 180° or for detection distances less than 500 mm).
- Between the FDR57 and the FQR57, a minimum clearance of 30 mm should be maintained.
- If the detection range is under 500 mm, the FDR57 and FQR57 should be installed at an angle of 90° relative to one another, to avoid possible overrangings and therefore faulty measurements.

Optimization of the signal quality

If the microwave barrier devices are installed in front of microwave-permeable windows or plugs, it is possible to optimize the signal quality by moving FDR57 and FQR57 on their longitudinal axis after an adjustment has been performed.

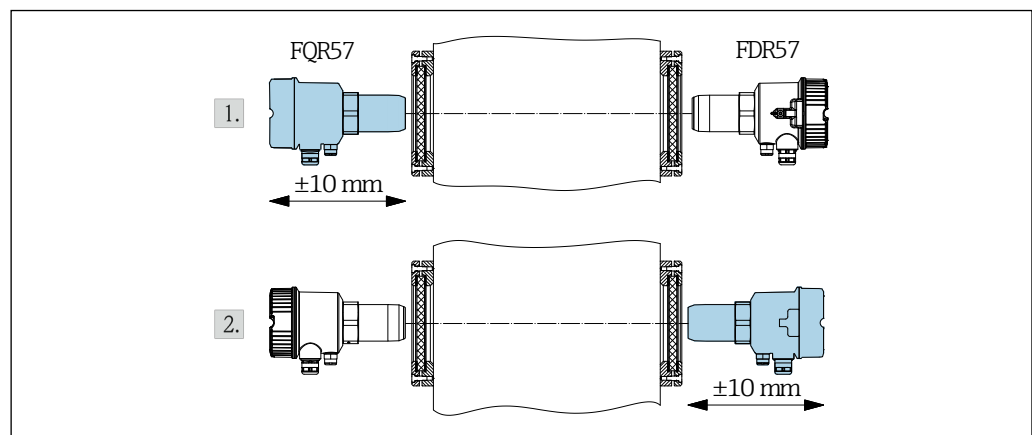

 6 Optimization of the signal quality

000000082

1. Loosen device 1 (FQR57 in this example) and move it slowly by ± 10 mm until a signal maximum (signal strength at FTR525 \rightarrow ???) is reached, then fix the device again.
2. Then loosen device 2 (FDR57 in this example) and move it slowly by ± 10 mm until a signal maximum is reached, fix the device again.

NOTICE

After each change in the position of the devices (in this case horizontal movement), a new calibration should be performed.

Operation with reflector(s)

If FDR57 and FQR57 cannot be positioned directly opposite each other for structural reasons, the microwave can be deflected via flat metal mirrors (reflectors).

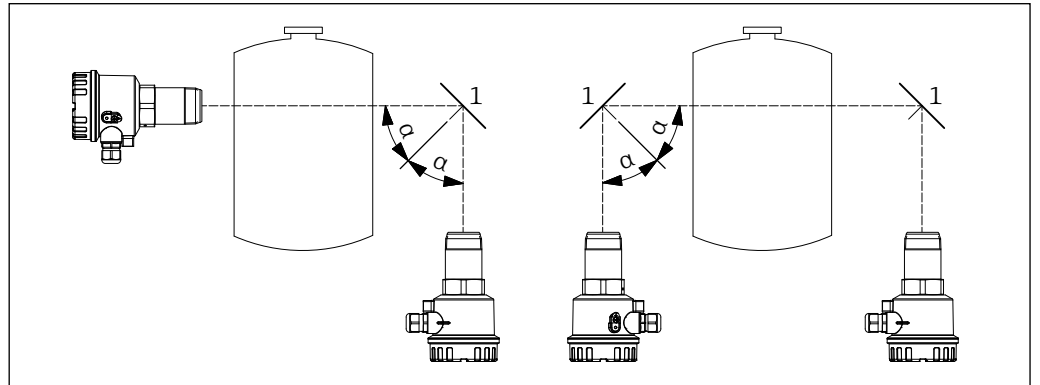

7 Reflector operation

000000068

R Reflector

a Angle of entrance = angle of emission

NOTICE

- Note that the FDR57 and FQR57 have to be arranged symmetrically to the reflector (angle of entrance = angle of emission), as otherwise the FDR57 does not receive a signal that it can evaluate.
- By using reflectors, the range of the microwave barrier is reduced by approximately 10 % per reflector.

Parallel mode

In practice, in some instances, multiple microwave barriers are to be operated in parallel at one location (e.g. for multiple level limit detections in a pipe). To prevent the microwave barriers from influencing each other, you can select a separate channel (1 to 5) for each microwave barrier at the FTR525 Nivotester.

NOTICE

Use the channels in order, i.e. 1, 2, ..., 5, 1, ...



For details on the FTR525 Nivotester settings, please see the separate technical information (\rightarrow 34).

Installation instructions

Basically, there are two ways to mount the FDR57 and FQR57 devices:

- Process-contact mounting: The process connection with the transmission window come into direct contact with the medium.
- Mounting not in contact with the process: The process connection with the transmission window do not come into direct contact with the medium.

NOTICE

- For optimal orientation after mounting the electronics housing of the devices in the process, it can be rotated as desired (by 360°).
- Avoid interference from reflections at metal parts.
- A wide range of accessories is available for adapting the microwave oven to the respective process conditions (→ 24).

Assembly in contact with the process

The device is screwed directly into the process (for example, existing threads or vessel sleeves) with its process connection (R 1½ in accordance with EN 10226, 1½" NPT in accordance with ANSI/ASME B1.20.1 or G 1½ in accordance with ISO 228-1).

Direct mounting with screw-in thread

The simplest type of mounting is screwing into the process wall. For this purpose, a corresponding internal thread must be available on the process.

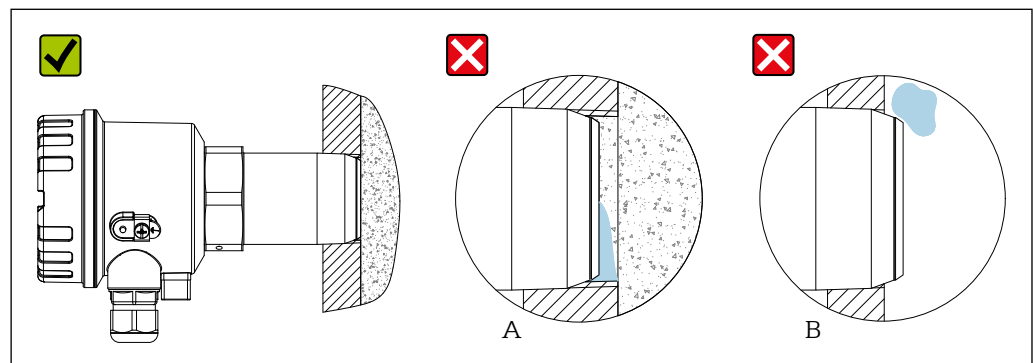

8 Direct mounting with threaded connection

000000080

NOTICE

- With direct mounting in the process wall, it must be ensured that the front edge of the process connection is flush with the internal edge.
- If the process connection is not screwed far enough into the process wall (A), there is a risk that material will collect in front of the device and cause attenuation of the microwave signal.
- If, on the other hand, the process connection is screwed too far into the process (B), there is a risk of damage due to large falling product pieces.

i When using the G 1½ -process connection (standard thread to ISO 228-1, hexagon SW55) with integrated counter nut, the devices can be flush mounted especially easily, as a parallel thread is used.

- i**
 - Weld-in adapters of type FAR52-A*, with corresponding internal thread, are available as accessories.
 - If the internal threads available in the process wall are different (R 2 to R 4 or 2 NPT to 4 NPT), additional screw-in adapters of type FAR52-B* are available as accessories.
 - Weld-in and screw-in adapters → 27

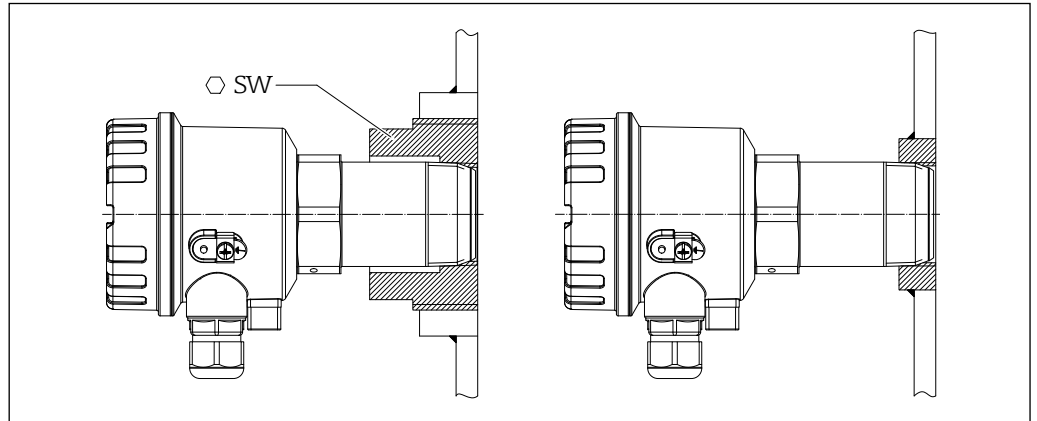

9 FAR52 weld-in or screw-in adapter

000000101

Installation examples

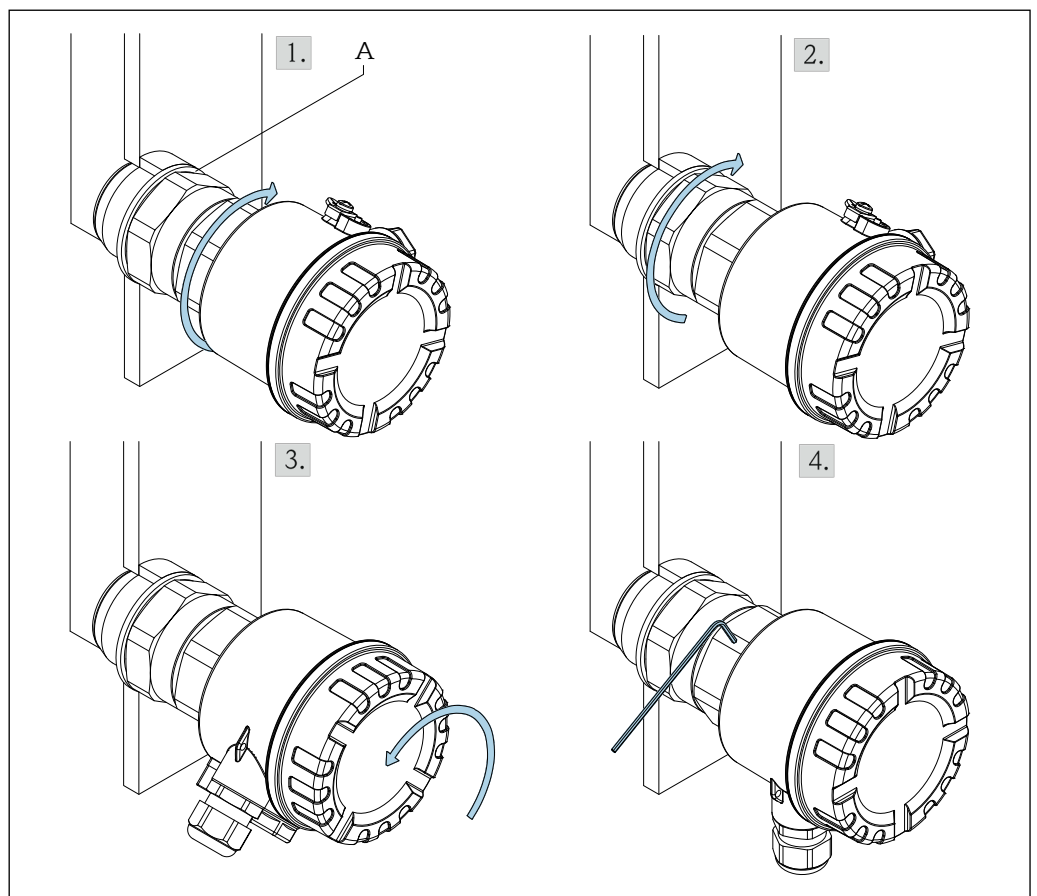

10 Installation with connection thread

000000069

A Enclosed process seal (only G 1½)

1. Screw conical (R 1½ or 1½ NPT) or cylindrical (G 1½) connection thread into the process (hexagon SW55)
2. Only for connection thread G 1½: Tighten the lock nut of the thread (also hexagon SW55).
3. Align FDR57 and FQR57 with each other (the fronts of both devices must be opposite each other on one axis).
4. Secure the housing (2 mm hex socket).

NOTICE

All installation variants are sealed with a suitable sealant (to be provided by the customer).

Mounting without contact with the process

Non-contact process mounting of the FDR57 and FQR57 is done in one of three ways:

- For a microwave-impermeable process wall (for example, metal vessel wall), mounting is done in front of microwave-permeable windows such as plastic plugs, ceramic disks, or sight glass fittings.
- In the case of a microwave-permeable process wall (for example, plastic container), mounting is carried out directly from the outside on the wall using appropriate adapters (for example, mounting brackets).
- For open processes, the mounting is arbitrary.

Mounting in front of microwave-impermeable process wall

If, due to the process conditions (such as high temperatures, high pressures or hazardous nature of the material), no direct installation in the microwave-impermeable process wall is possible, it is possible for the microwave barrier to emit its signal through an additionally installed plug.

The following materials have been tested and are suitable for radiation:

- Plastics (virginal, unfilled) such as polytetrafluorethylene (PTFE), polyethylene (PE) or polypropylene (PP)
- Aluminum oxide ceramic (purity min. 99.5%, uncolored)
- Borosilicate glass (uncolored)

NOTICE

Colorations or added (colored) substances can cause a potentially high signal attenuation, depending on the material, and are therefore not suitable for this purpose.

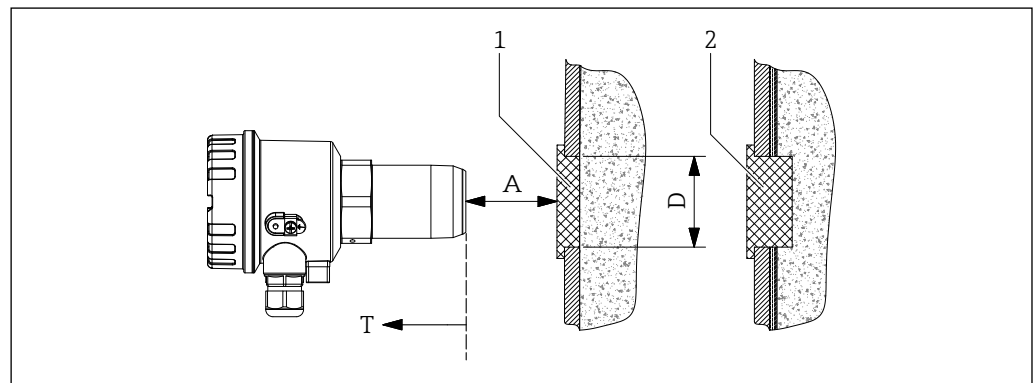

11 Mounting in front of a microwave-permeable process wall

000000072

- 1 Microwave permeable plug
- 2 Microwave-permeable plug for condensation on the inner wall of the container

NOTICE

- With bracket mounting in front of a microwave-permeable plug and the risk of the formation of condensate on the inner wall of the container, we recommend a plug protruding into the process (2).
- The maximum temperature **T** at the FDR57 and FQR57 must be observed.
- Distance **A** is based on the clear opening area **D**. To prevent possible signal attenuation, we recommend keeping the distance as short as possible (e.g. max. 40 mm at DN50).

Mounting in front of microwave-permeable sight glass fitting

If the process wall is not permeable, it is possible to have the microwave barrier emit its signal from outside through a suitable sight glass fitting. The sight glass in this fitting is made of uncolored borosilicate glass.

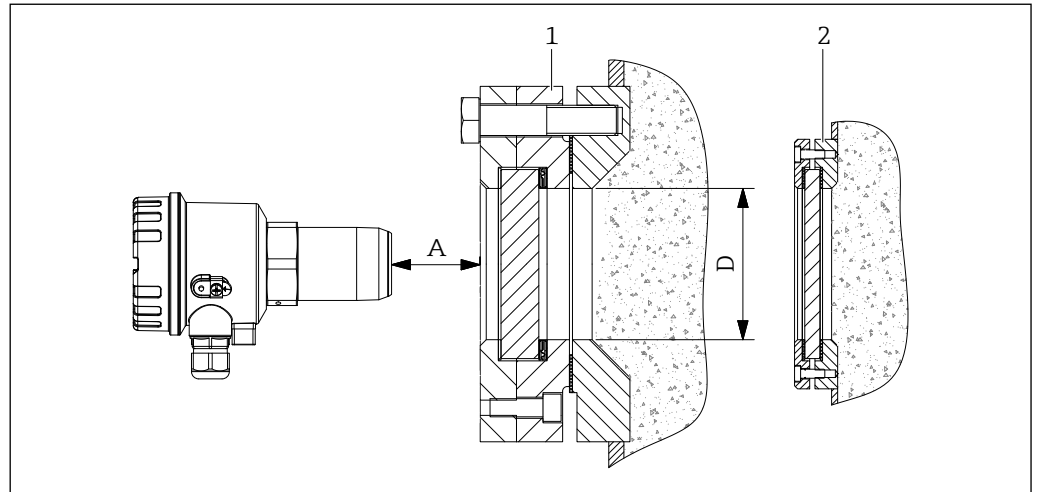

12 Mounting in front of microwave-permeable sight glass fitting

000000073

- 1 Sight glass fitting for processes up to 1 MPa
- 2 Sight glass fitting for unpressurized processes

NOTICE

Distance **A** is based on the clear opening **D** and the temperature in this area. To prevent possible signal attenuation, we recommend keeping the distance as short as possible (e.g. max. 40 mm at DN50).

Sight glass fittings should in principle only be installed at places where no material can collect on the process side (risk of incorrect measurements).

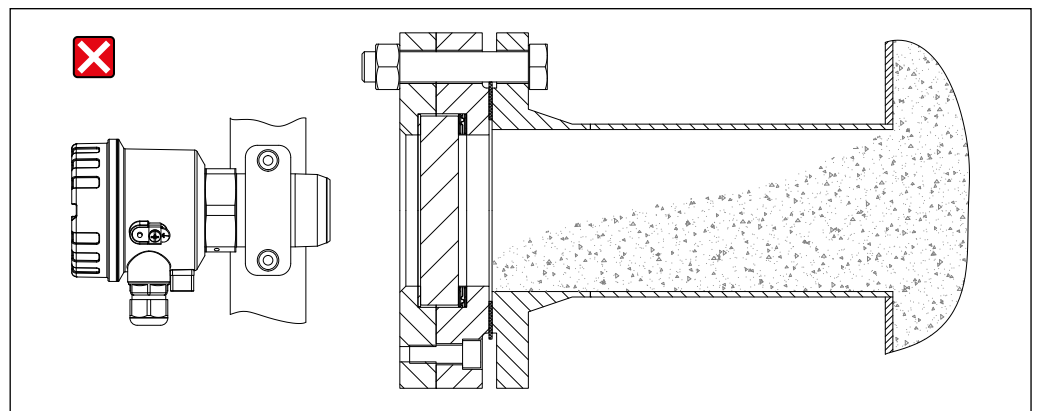

13 Impermissible mounting with the risk of material collection

000000086

i Suitable sight glass fittings made of stainless steel with borosilicate glass are available as accessories (→ 28).

Mounting on process nozzles

Mounting on a process nozzle offers the following advantages:

- By using available nozzles, no modifications of the process are required.
- The use of suitable plugs can prevent material from collecting in the nozzle.
- At the same time, the plug acts as wear protection for the microwave barrier and can be replaced easily in the event of significant wear.
- Mounting or disassembly of the devices can be carried out during ongoing operation, which significantly simplifies the service process.

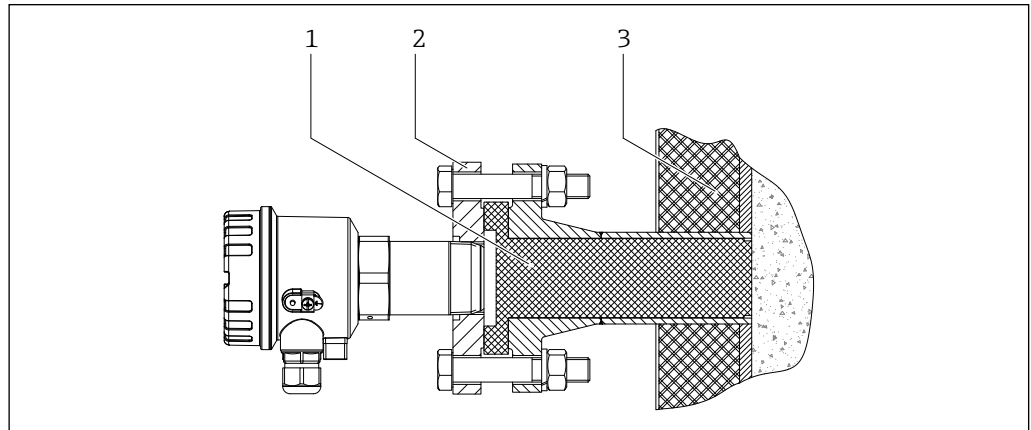

000000088

14 Mounting on available process nozzles

- 1 Plug
- 2 Mounting flange
- 3 Process insulation

- i
 - Suitable mounting flanges with corresponding connection threads made of stainless steel and plugs made of PTFE or aluminum oxide ceramic for the available process nozzles are available as accessories.
 - Process nozzles of type FAR50, consisting of connection nozzle, plug and mounting flange, are available as accessories in different sizes and materials.
 - Accessories → 24

If there is a risk of buildup, assembly methods that could promote this process should be avoided.

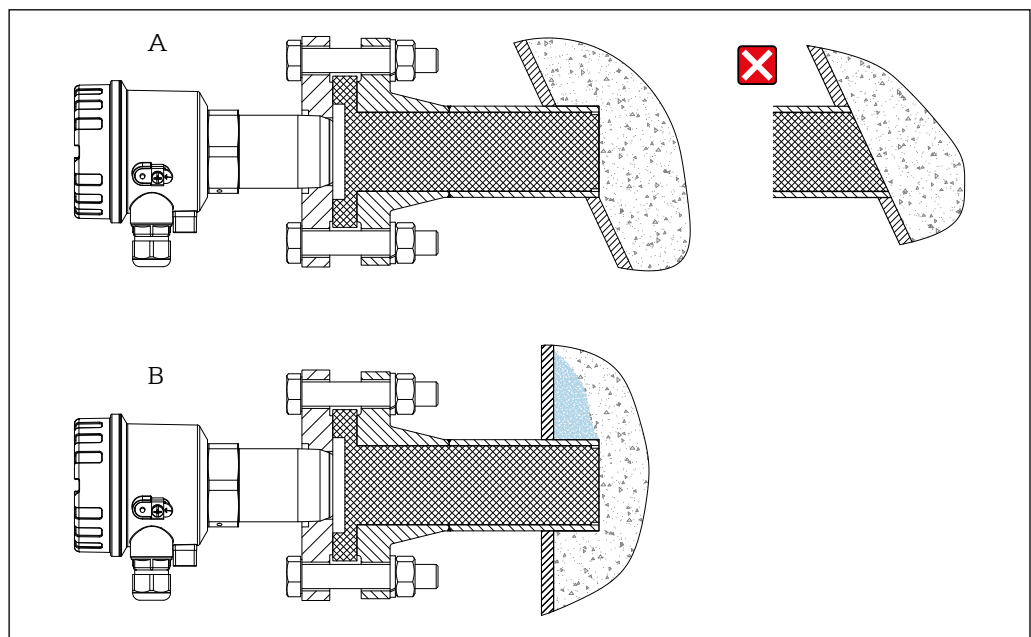

000000074

15 Mounting with the risk of accumulations

NOTICE

- For non-vertical process walls, we recommend mounting the process nozzle far enough into the process that no material can collect in front of it **(A)**.
- For process nozzle mounting and when there is a risk of material building up on the inner wall of the container, we recommend a nozzle that protrudes into the process **(B)**.
- The maximum plug length is dependent on the attenuation and water absorption of the material. Please note the manufacturer's instructions in this regard.
- When there is a risk of condensate forming between the process connection of the FDR57/FQR57 and the plug, we recommend using the process nozzle type FAR50 (→ 31), which is equipped with a mounting flange with a pressure equalization element.

For existing process nozzles, the optionally available plug-in adapters of type FAR51 can be used. These are simply plugged in and fixed, which significantly reduces the assembly effort (also with regard to maintenance).

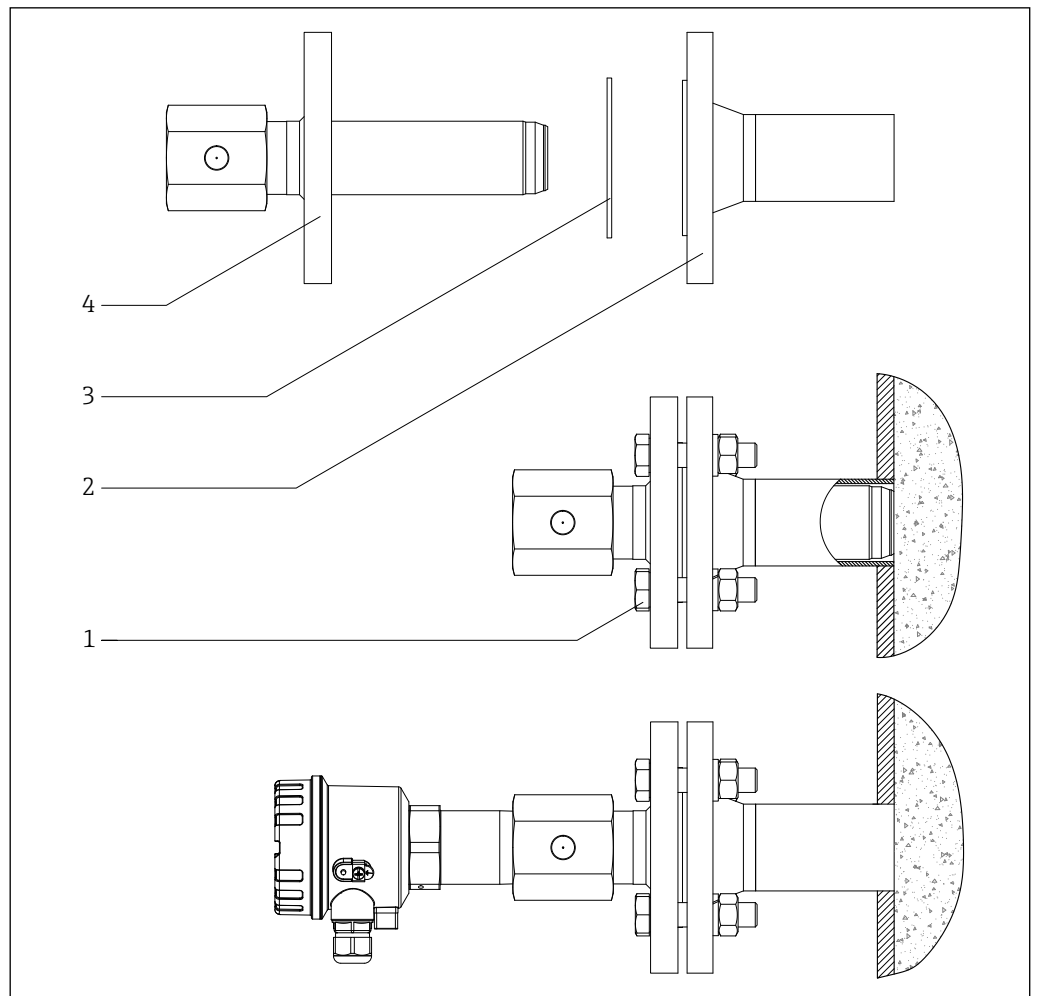

16 Mounting with FAR51 insertion adapter

000000085

- 1 Customer-supplied installation material
- 2 Process nozzle
- 3 Customer-supplied gasket
- 4 Insertion adapter

i For process temperatures of +70 to +450 °C (+158 to +842 °F), plug-in adapters for stainless steel flange nozzles of type FAR51 are available as accessories (→ 30).

Mounting with high pressure adapter

For applications with a high process pressure up to 2.1 MPa (21 bar) absolute, we recommend the following high pressure adapter (→ 27).

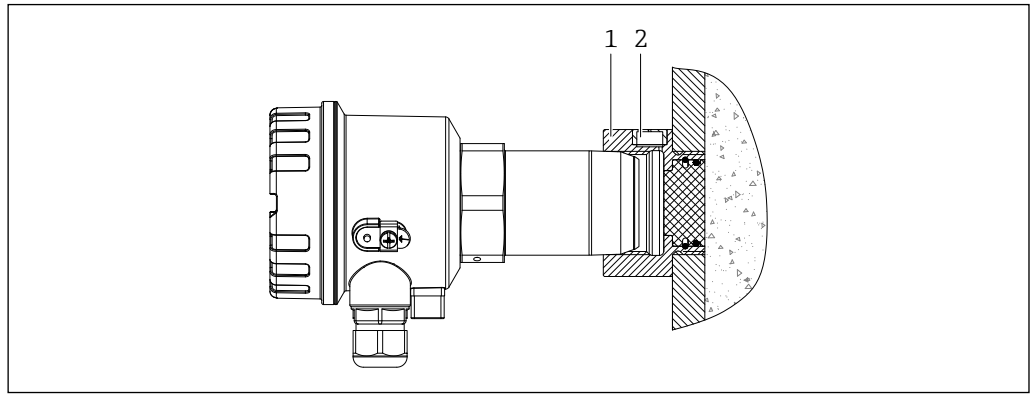

000000071

17 Mounting with high-pressure adapter

- 1 High pressure adapter
- 2 Integrated venting element

NOTICE

The maximum temperature at the FDR57/FQR57 must be observed.

Mounting with high temperature adapter and length extensions

For simple and easily accessible high temperature applications in the range of +70 to +450 °C (+158 to +842 °F), there is a simple adapter for the device connection threads G 1½ and 1½ NPT with flush aluminum oxide ceramic, this can be extended with extensions.

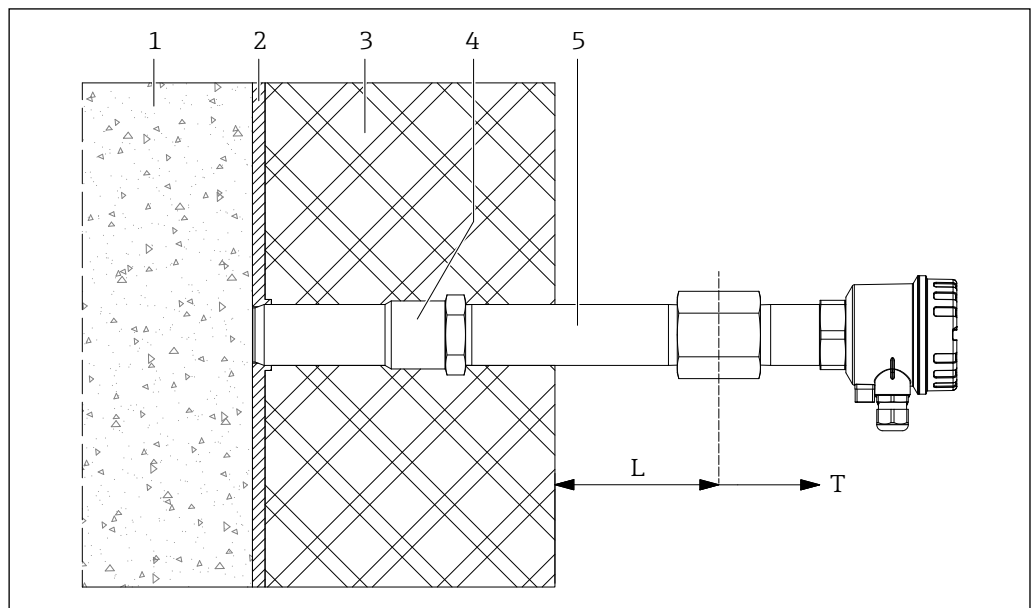

000000075

18 Mounting with high temperature adapter and length extensions

- 1 Wall
- 2 Insulation
- 3 HT-Adapter
- 4 Extension

NOTICE

- The maximum process pressure of 80 to 510 kPa (0.8 to 5.1 bar) absolute at the high-temperature adapter must be observed.
- The maximum temperature **T** of +70 °C (+158 °F) at the process connection of FDR57/FQR57 devices must be observed exceeding this temperature will cause destruction.
- **L** is to be selected according to the process and ambient temperatures.

 Suitable high temperature adapters and stainless steel length extensions for FDR57/FQR57 are available as accessories (→ 33).

Mounting with spacer tube (wave guide)

For many processes, mounting with a spacer tube is a simple and cost-effective way of separating the devices of the microwave barrier FDR57/FQR57 from the high process temperatures of +70 to +450 °C (+158 to +842 °F). The spacer tube can be secured in place in various ways, depending on the application conditions (e.g. screwed into the process wall, bolted-on mounting brackets, welded or clamped to available cross beams).

We also recommend this mounting method for processes that are lined with clay or similar materials on the inside. The spacer tube can be glued into place, for example.

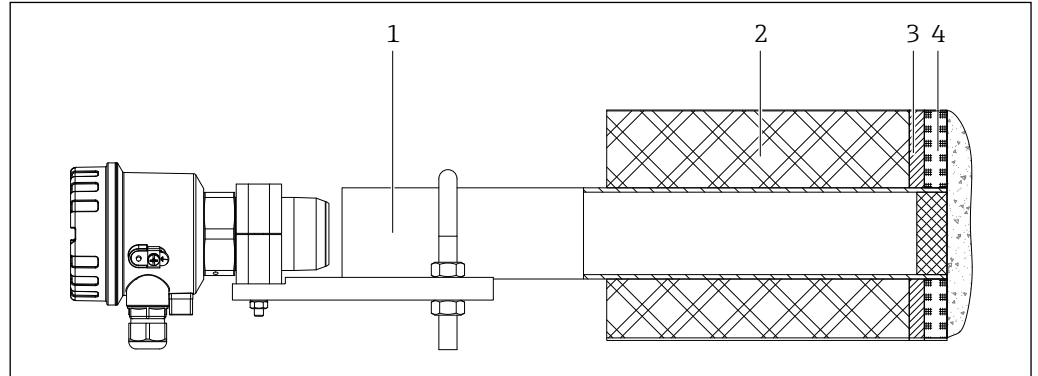

19 Mounting with spacer tube

000000087

- 1 Spacer tube
- 2 Process insulation
- 3 Container wall
- 4 Inner lining

- i
 - Suitable spacer tubes of type FAR53, made of steel or stainless steel, are available as accessories in different versions (→ 31).
 - The mounting of devices with mounting brackets (connection with mounting plate) and pipe clamps (connection of mounting plate with spacer tube) allows for movement by ± 10 mm and thus for optimal alignment of the microwave barrier (→ 10 „Optimization of the signal quality“).

NOTICE

When there is a risk of condensate forming in the spacer tube, we recommend using process nozzle type FAR50 (→ 31), which is equipped with a mounting flange with a pressure equalization element.

For structural or space reasons, it may be necessary to mount the FDR57 and FQR57 devices at an angle to the planned mounting location. In this case, a spacer tube can be used as a wave guide, meaning that no additional signal attenuation occurs due to the wave guide effect.

NOTICE

- The pipe can be made of any desired metallic material.
- Edges inside the pipe (for example at transitions) can cause signal attenuation and thus should be avoided wherever possible.

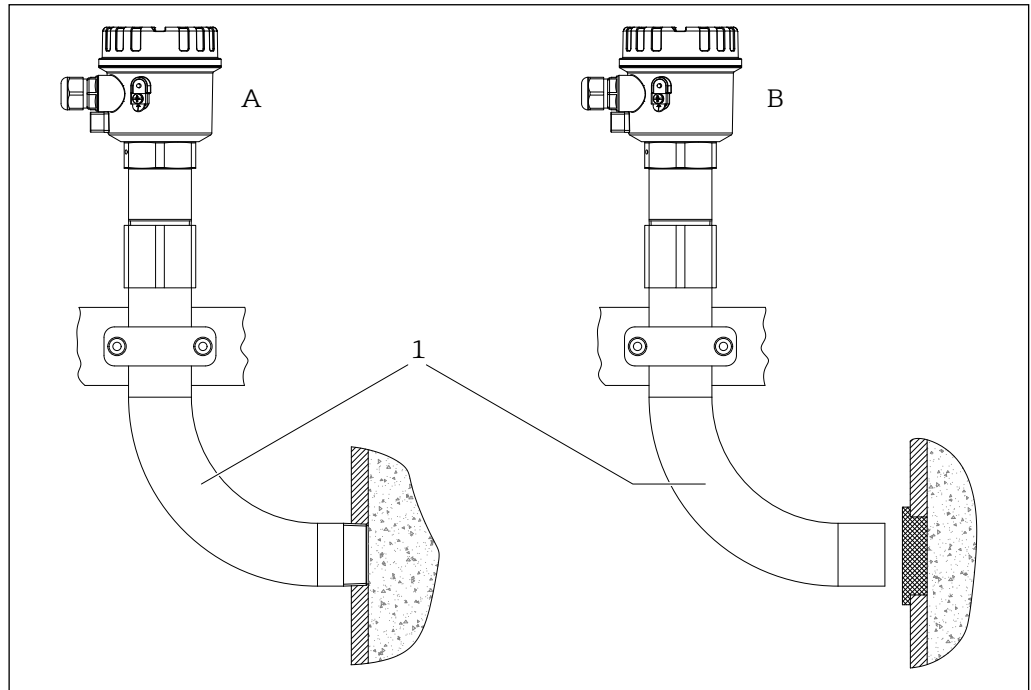

000000092

20 Mounting with wave guide

- A Mounting directly in the process with connection thread
- B Mounting in front of the process plug without connection thread
- 1 Wave guide

i Suitable stainless steel wave guides of type FAR55 are available as accessories in different versions (→ 31).

Mounting with open processes

Mounting in open processes can be done with a simple mounting bracket.

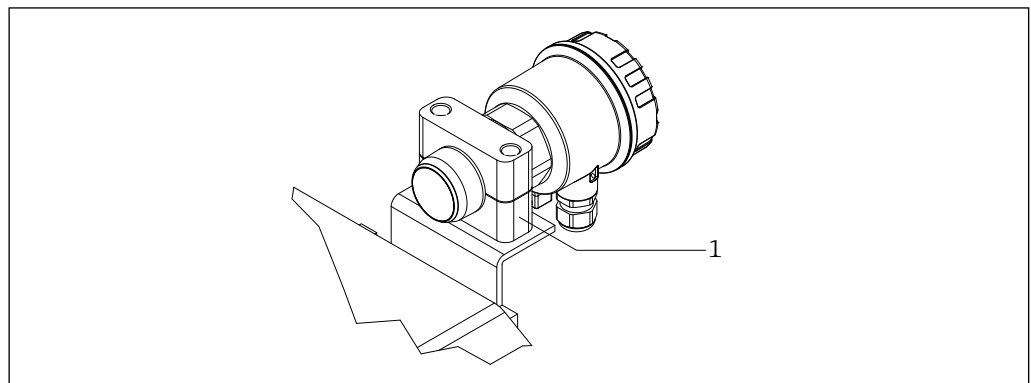

000000084

21 Mounting with open processes

- 1 Mounting bracket

i Suitable mounting brackets made of plastic or aluminum are available as accessories (→ 25).

Connecting cable length Max. 500 m (length of each connecting cable between the FTR525 Nivotester and the FDR57 or FQR57)

Connecting cable See cable specification (→ 8)

Environment

Operating temperature range	-40 to +70 °C (-40 to +158 °F)
	For outdoor operation in strong sunlight: <ul style="list-style-type: none"> ▪ Mount the device in the shade ▪ Avoid direct sunlight, particularly in warmer climatic regions ▪ Use a protective cover, which can be ordered as an accessory (→ 33)

Storage temperature	-40 to +80 °C (-40 to +176 °F)
----------------------------	--------------------------------

Degree of protection	<ul style="list-style-type: none"> ▪ IP 66 (with closed housing) ▪ IP 20 (with open housing)
-----------------------------	--

Vibration resistance	See vibration effects (→ 9)
-----------------------------	--

Electromagnetic Compatibility (EMC)	<ul style="list-style-type: none"> ▪ Interference emission to EN 61326, Electrical Equipment Class B ▪ Interference immunity to EN 61326, Appendix A (Industrial) ▪ Normal installation cable is sufficient for the wiring.
--	--

Process

Process temperature range	<ul style="list-style-type: none"> ▪ Without optional process adapter: -40 to +70 °C (-40 to +158 °F) ▪ With optional high temperature adapter: -40 to +450 °C (-40 to +842 °F) ▪ Note deviating temperature ranges with the accessories offered!
----------------------------------	--

Process pressure range	<ul style="list-style-type: none"> ▪ 50 to 680 kPa (0.5 to 6.8 bar) absolute, only to be observed with FDR57/FQR57 installed directly in the process ▪ 80 to 510 kPa (0.8 to 5.1 bar) absolute, with use of the optional high temperature adapter ▪ 50 kPa to 2.1 MPa (0.5 to 21 bar) absolute, with use of the optional high pressure adapter ▪ Note deviating pressure ranges with the accessories offered.
-------------------------------	---

Vibration	See vibration effects (→ 9)
------------------	--

Mechanical construction

Dimensions

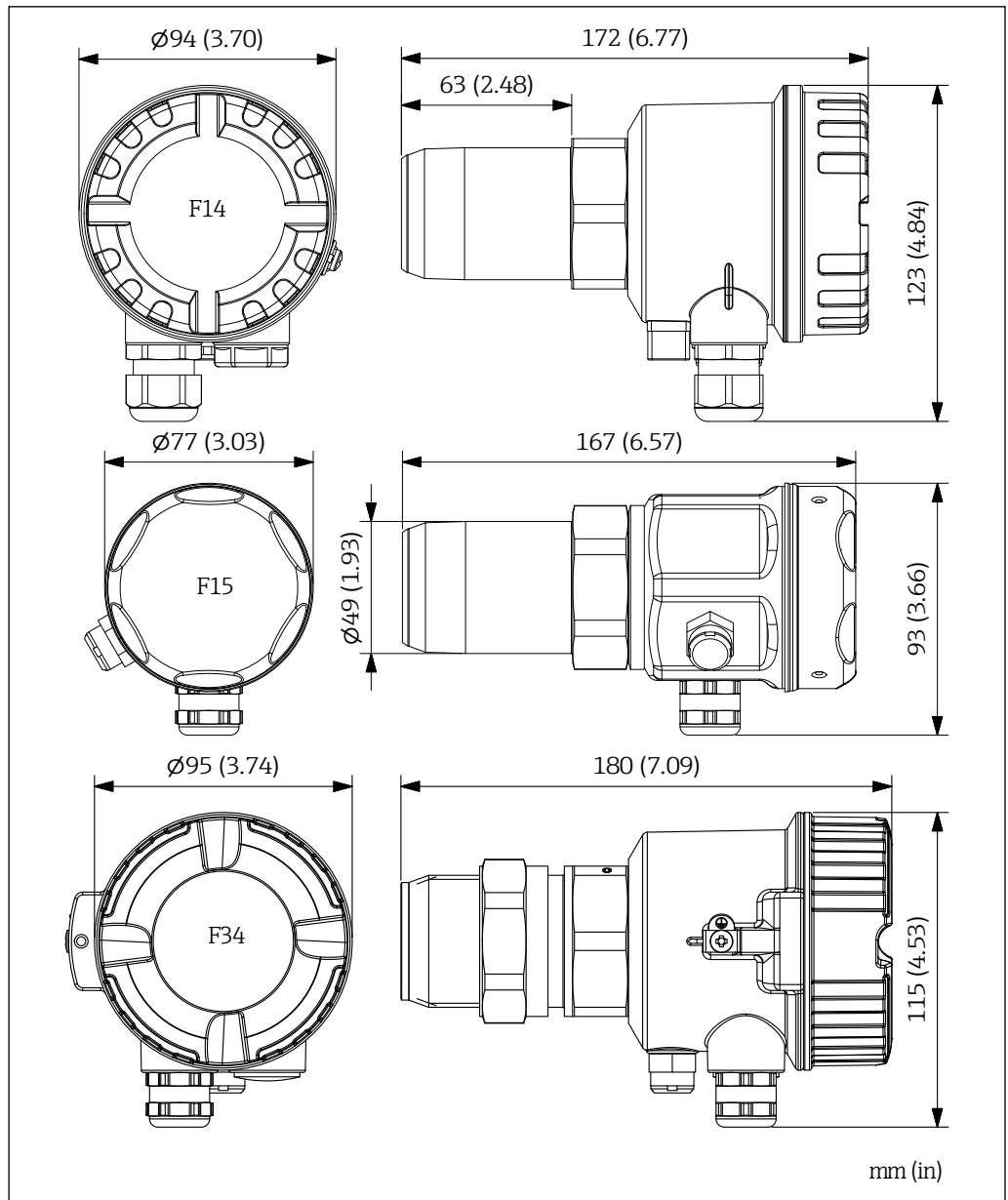

22 Dimensions

000000100

Weight

1.1 to 1.7 kg (2.43 to 3.75 lbs), depending on the selected housing and process connection

Materials	<ul style="list-style-type: none"> ■ Stainless steel 316Ti (1.4571): <ul style="list-style-type: none"> - Process connection - Pressure equalization element (F15/F34 housing) ■ Stainless steel 316L (1.4435): <ul style="list-style-type: none"> - F15 housing - Adapter ½ NPT (F15/F34 housing) ■ Aluminum: <ul style="list-style-type: none"> - F34 housing ■ Plastic: <ul style="list-style-type: none"> - F14 housing - M20 cable gland, adapter ½ NPT and pressure equalization element (F14 housing) ■ Die-cast zinc: <ul style="list-style-type: none"> - M12 plug connector, nickel-plated - Harting plug connector, powder-coated ■ Brass, nickel-plated: <ul style="list-style-type: none"> - M20 cable gland (F15/F34 housing)
------------------	---

Process connections	<p>Connection thread:</p> <ul style="list-style-type: none"> ■ R 1½ in accordance with EN 10226 ■ 1½ NPT in accordance with ANSI/ASME ■ G 1½ in accordance with ISO 228-1
----------------------------	--

Operability

Operation	Operation and configuration is carried out entirely via the Nivotester FTR525 process transmitter with control unit.
------------------	--

Display elements	When the housings of the FQR57 and the FDR57 are open, a green LED is visible, which indicates a connected power supply (provided by the FTR525 Nivotester).
-------------------------	--

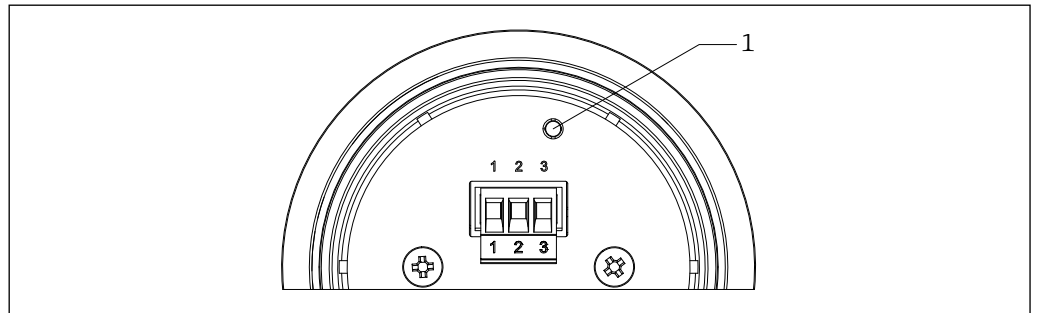

23 Anzeigeelemente

1 Leuchtdiode (grün)

000000078

Certificates and approvals

CE mark	<p>The FDR57/FQR57 microwave barrier meets the legal requirements of the applicable EU guidelines. These are listed in the corresponding EU Declaration of Conformity, together with the applied standards.</p> <p>By applying the CE mark, Endress+Hauser confirms that the device has passed the necessary tests.</p>
----------------	---

RoHS	The microwave barrier complies with the substance restrictions of the Restriction of Hazardous Substances Directive 2011/65/EU and the Delegated Directive 2015/863/EU.
-------------	---

Ex approval

The measuring device is certified for use in hazardous areas and the safety instructions to be observed are provided in the separate "Safety Instructions" (XA) document. This is also referenced on the nameplate.



The separate Ex documentation (XA) with all relevant data regarding explosion protection can be obtained from your Endress+Hauser sales center or as a download from www.endress.com.

Radio approval

- EN 300440
Short range radio devices (SRD) – radio devices for operation in a frequency range of 1 GHz to 40 GHz
- FCC Rule Parts 15C
- IC according to RSS-Gen Issue 4 and RSS-310

External standards and guidelines

- EN 60529
Degrees of protection through housing (IP code)
- EN 61010-1
Protection measures for electrical equipment for measurement, control, regulation and laboratory procedures
- EN 61326
Interference emission (equipment in class B) and interference immunity (appendix A – industrial)
- EN 60079-0
Hazardous areas – part 0: Equipment – general requirements
- EN 60079-11
Potentially explosive atmosphere – part 11: Device protection through intrinsic safety "i"
- EN IEC 63000
Technical documentation for the assessment of electrical and electronic products with respect to the restriction of hazardous substances

Ordering information

Detailed ordering information is available from the following sources:

- In the product configurator on the Endress+Hauser website: www.endress.com → Select your country → Products → Select measurement technologies, software or components → Select product (selection lists: Measuring methods, product family, etc.) → Device support (right column): Configure the selected product → The product configurator opens for the selected product.
- From your Endress+Hauser sales center: www.addresses.endress.com



Product Configurator – the tool for individual product configuration

- Up-to-the-minute configuration data
- Depending on the device: Direct input of measuring point-specific information such as measuring range or operating language
- Automatic verification of exclusion criteria
- Automatic creation of the order code and its breakdown in PDF or Excel output format

Scope of delivery

The scope of delivery includes the FDR57 and FQR57 in a box with operating instructions included. Depending on the order code, the scope may be extended to include a matching mating connector (electrical connections).

Accessories

Various accessories are available for the device, and can be ordered with the device or at a later stage from Endress+Hauser. Detailed information on the order code in question is available from your local Endress+Hauser sales center or on the product page of the Endress+Hauser website: www.endress.com.

Plug connector

For device variants with plug-in connectors, the following female connectors can be used:

- Order No.:
71381872, M12, 4-pin
71381882, Harting HAN8D, 8-pin

 For device variants with electrical connections **F** and **J**, the corresponding plug connectors are already included in the scope of delivery.

Pre-terminated connecting cable

For device variants with plug-in connectors, the following pre-terminated connection cables can be used:

- Order No.:
71381853, M12 female cable connector, 4 x 0.34 mm², PUR, length 2 m (6.45 ft)
71381870, M12 female cable connector, 4 x 0.34 mm², PUR, length 5 m (16.40 ft)
71381877, Harting HAN8D female cable connector, 4 x 0.75 mm², PUR, length 2 m (6.45 ft)
71381879, Harting HAN8D female cable connector, 4 x 0.75 mm², PUR, length 5 m (16.40 ft)
- Weight: Approx. 0.19 kg (M12 connecting cable, 2 m)/0.45 kg (Harting connecting cable, 5 m)

Mounting bracket

For mounting on frames, cross beams or similar which are already available, the following mounting brackets can be used:

- Order No.:
52017501, aluminum
52017502, plastic
- Weight: Approx. 0.06 kg (plastic)/0.22 kg (aluminum)
- The delivery does not include any mounting screws, as the type and length are dependent on on-site conditions.

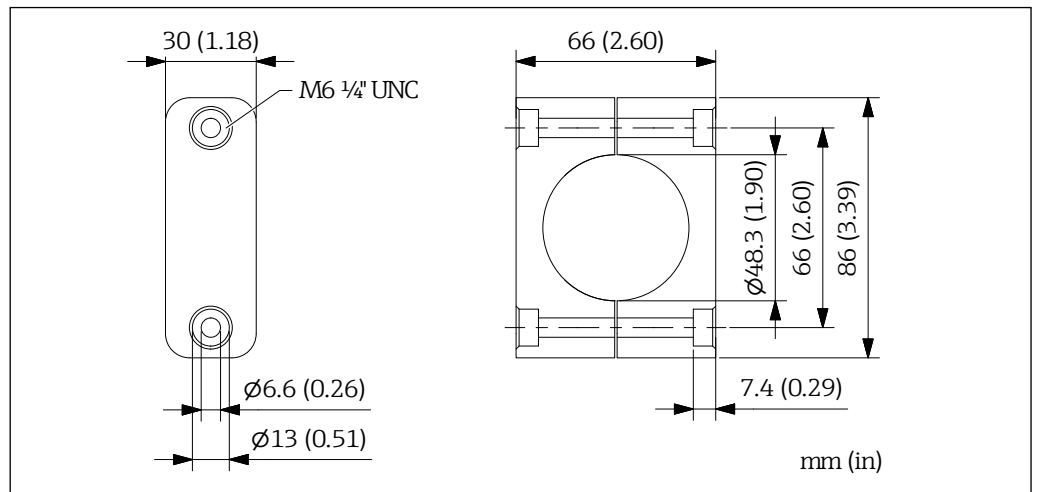

 24 Mounting bracket dimensions

000000097

Mounting flange

The following mounting flanges can be used for mounting on available process nozzles with connection dimensions in accordance with DIN EN 1092-1:

- Order No.:
71006348, DN40 PN40, Rp 1½ internal thread
71108383, DN40 PN40, Rp 1½ internal thread, inspection certificate in accordance with EN 10204-3.1
71381884, DN40 PN40, G 1½ internal thread
71381885, DN40 PN40, G 1½ internal thread, inspection certificate in accordance with EN 10204-3.1
71006350, DN50 PN16, Rp 1½ internal thread
71108388, DN50 PN16, Rp 1½ internal thread, inspection certificate in accordance with EN 10204-3.1
71381887, DN50 PN16, G 1½ internal thread
71381888, DN50 PN16, G 1½ internal thread, inspection certificate in accordance with EN 10204-3.1
71006352, DN100 PN16, Rp 1½ internal thread
71108390, DN100 PN16, Rp 1½ internal thread, inspection certificate in accordance with EN 10204-3.1
71381890, DN100 PN16, G 1½ internal thread
71381891, DN100 PN16, G 1½ internal thread, inspection certificate in accordance with EN 10204-3.1
- Material: 316Ti stainless steel (1.4571)
- Weight: DN40 approx. 2.3 kg (5.07 lbs) to DN100 approx. 5.8 kg (12.79 lbs)

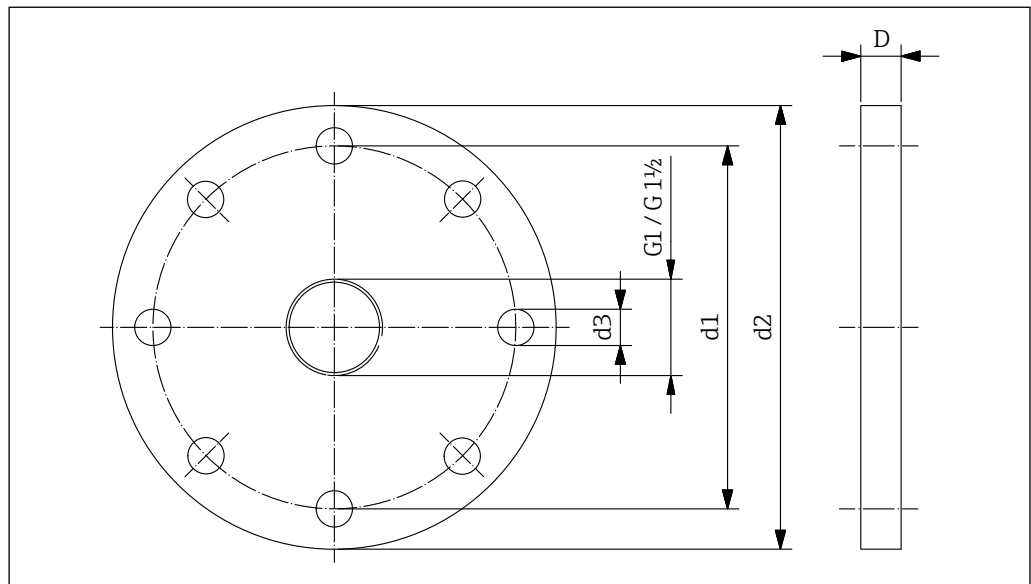

000000038

25 Dimensions of mounting flange (connection dimensions in accordance with EN 1092-1)

Flange	d1 mm (in)	d2 mm (in)	d3 mm (in)	D mm (in)	holes
DN40/PN40	110 (4.33)	150 (5.91)	18 (0.71)	18 (0.71)	4
DN50/PN16	125 (4.92)	165 (6.50)	18 (0.71)	18 (0.71)	4
DN100/PN16	180 (7.09)	220 (8.66)	18 (0.71)	20 (0.79)	8

The following mounting flanges can be used for mounting on available process nozzles with connection dimensions in accordance with ANSI/ASME B16.5:

■ Order No.:

71006349, 1½" 150 lbs, 1½ NPT internal thread

71108387, 1½" 150 lbs, 1½ NPT internal thread, inspection certificate in accordance with EN 10204-3.1

71006351, 2" 150 lbs, 1½ NPT internal thread

71108389, 2" 150 lbs, 1½ NPT internal thread, inspection certificate in accordance with EN 10204-3.1

71006353, 4" 150 lbs, 1½ NPT internal thread

71108391, 4" 150 lbs, 1½ NPT internal thread, inspection certificate in accordance with EN 10204-3.1

■ Material: 316Ti stainless steel (1.4571)

■ Weight: 1½" approx. 1.5 kg (3.31 lbs) to 4" approx. 6.8 kg (15.0 lbs)

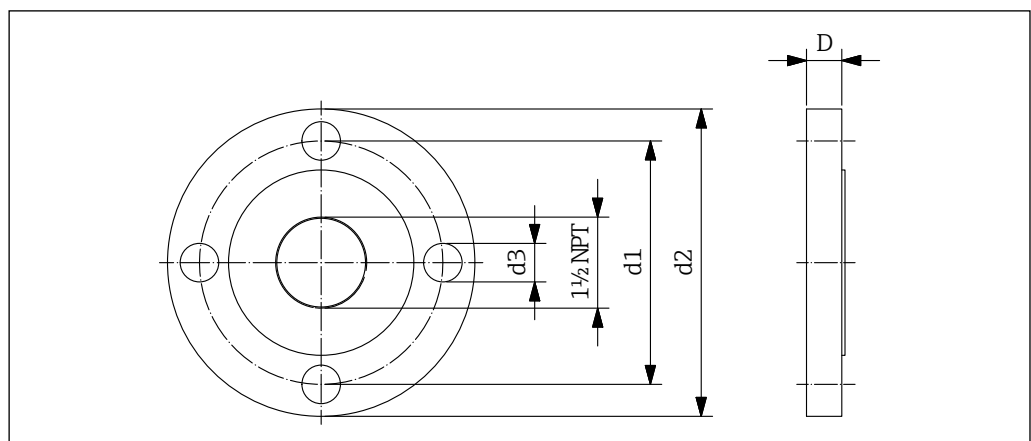

000000039

26 Dimensions of mounting flange (connection dimension in accordance with ANSI/ASME B16.5)

Flange	d1 mm (in)	d2 mm (in)	d3 mm (in)	D mm (in)	holes
1½" 150 lbs	98.6 (3.88)	127 (5.00)	15.7 (0.62)	17.5 (0.69)	4
2" 150 lbs	120.7 (4.75)	152.4 (6.00)	19.1 (0.75)	19.1 (0.75)	4
4" 150 lbs	190.5 (7.50)	228.6 (9.00)	19.1 (0.75)	23.9 (0.94)	8

Weld-in or screw-in adapter

For mounting in process walls with existing threads or bores, adapters of type FAR52 can be used (→ TI01369F/97/EN):

- Weld-in adapter with internal thread Rp 1½, 1½ NPT and G 1½
- Screw-in adapter for thread R 2 to R 4 and 2 NPT to 4 NPT, with internal thread R 1½ or 1½ NPT
- Material: 316Ti stainless steel (1.4571) and P235GH steel (1.0345)
- Weight: FAR52-AAAA1A approx. 0.3 kg (0.66 lbs) to FAR52-BVL22B approx. 1.8 kg (4 lbs)

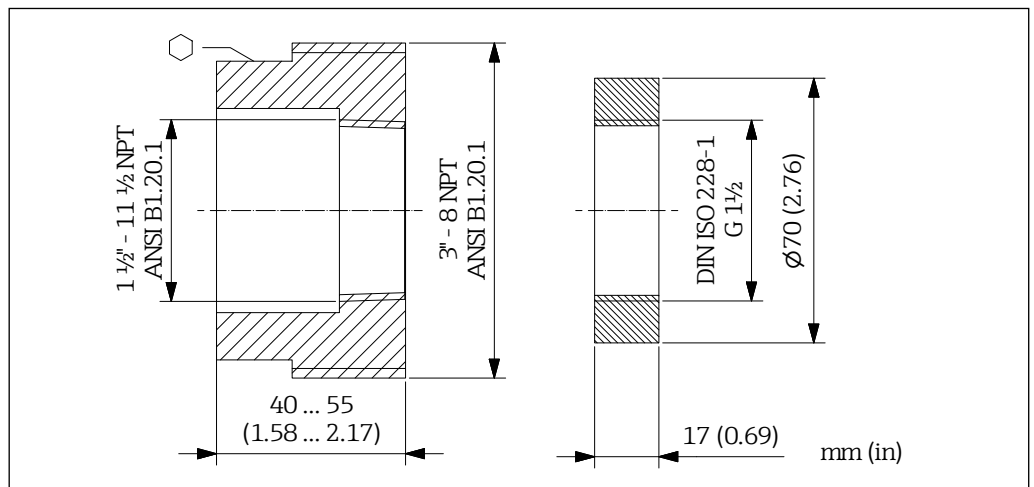

27 Dimensions of weld-in or screw-in adapter FAR52

000000093

High pressure adapter

For mounting of with a microwave-impermeable process wall and high process pressure up to 2.1 MPa (21 bar) absolute, the following high pressure adapters can be used:

- Order No.:
 - 71381894: Process and device connecting thread G 1½ in accordance with ISO 228-1
 - 71381898: Process and device connecting thread G 1½ in accordance with ISO 228-1, inspection certificate in accordance with EN 10204-3.1
 - 71381899: Process connecting thread G 1½ in accordance with ISO 228-1, device connecting thread 1½ NPT in accordance with ANSI/ASME
 - 71381904: Process connecting thread G 1½ in accordance with ISO 228-1, device connecting thread 1½ NPT in accordance with ANSI/ASME, inspection certificate in accordance with EN 10204-3.1
- Material: 316Ti stainless steel, PTFE window transmission
- Weight: Approx. 0.8 kg (1.76 lbs)

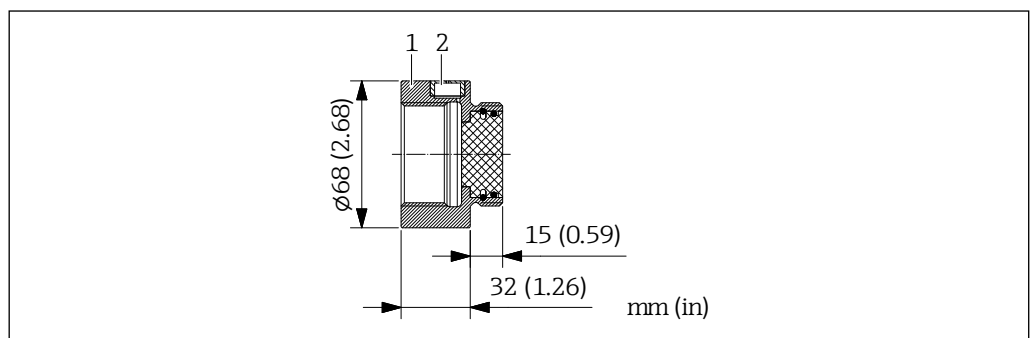

28 Dimensions of high-pressure adapter

000000091

- 1 High pressure adapter
- 2 Integrated venting element

Plug

For mounting with microwave-impermeable process walls, plugs of type FAR54 can be used
(→ TI01371F/97/EN):

- Material: PTFE and aluminum oxide ceramic
- Process temperature: Max. -40 to +800 °C (-40 to +1472 °F)
- Weight: FAR54-ABCBFAAAA2 approx. 0.06 kg (0.13 lbs) to FAR54-CCBCABEBJ3 approx. 3.2 kg (7.05 lbs)

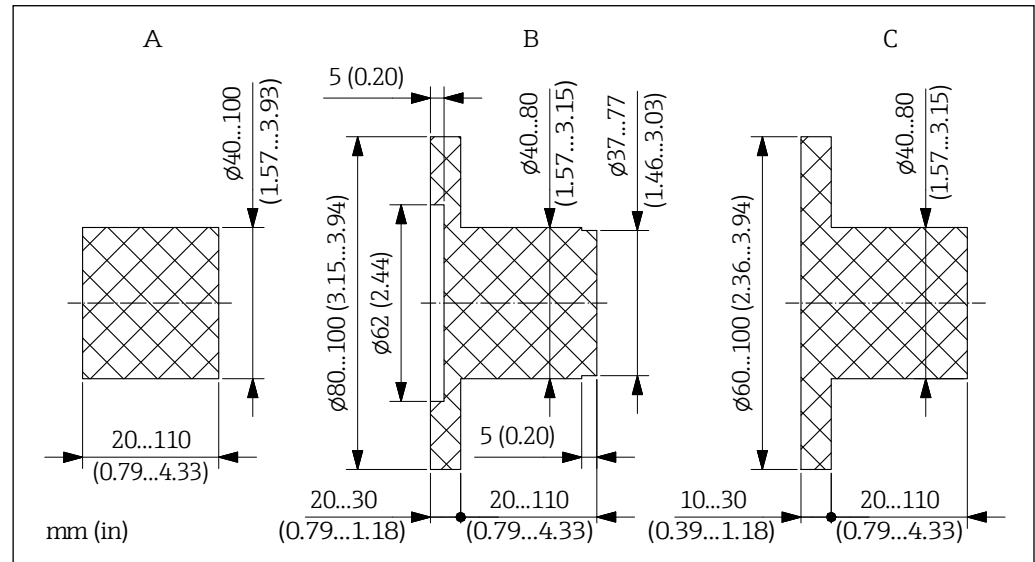

29 Dimensions of FAR54 plugs

000000041

Sight glass fitting

For mounting with microwave-impermeable process walls and unpressurized process, the following sight glass fittings can be used for welding on or in:

- Order No.:
71026443, DN50
71026444, DN80
71026445, DN100
- Material: 316Ti stainless steel, silicon seal (max. +200 °C/+392 °F)
- Weight: DN50 approx. 2.4 kg (5.29 lbs) to DN100 approx. 4.1 kg (9.04 lbs)
- The delivery includes the inspection glass fitting, incl. seals and mounting screws.

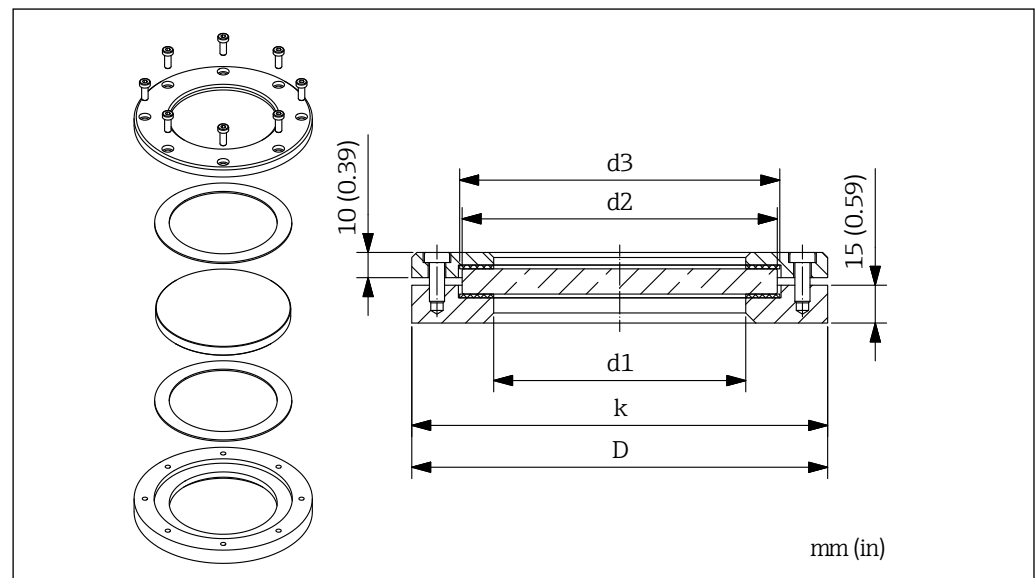

30 Dimensions of sight glass fitting for welding on/in for unpressurized processes

000000042

DN	d1 mm (in)	d2 mm (in)	d3 mm (in)	D mm (in)	k mm (in)
50	80 (3.15)	100 (3.94)	102 (4.02)	140 (5.51)	120 (4.72)
80	100 (3.94)	125 (4.92)	127 (5.00)	165 (6.50)	145 (5.71)
100	125 (4.92)	150 (5.91)	152 (5.98)	190 (7.48)	170 (6.69)

For mounting with microwave-impermeable process walls and process up to max. 1 MPa (10 bar), the following sight glass fittings can be used for welding on or in:

- Order No.:
71026446, DN50
71026447, DN80
71026448, DN100
- Material: 316Ti stainless steel, silicon seal (max. +200 °C/+392 °F)
- Weight: DN50 approx. 6.7 kg (14.77 lbs) to DN100 approx. 13.0 kg (28.66 lbs)
- The delivery includes the inspection glass fitting, incl. seals and mounting screws.

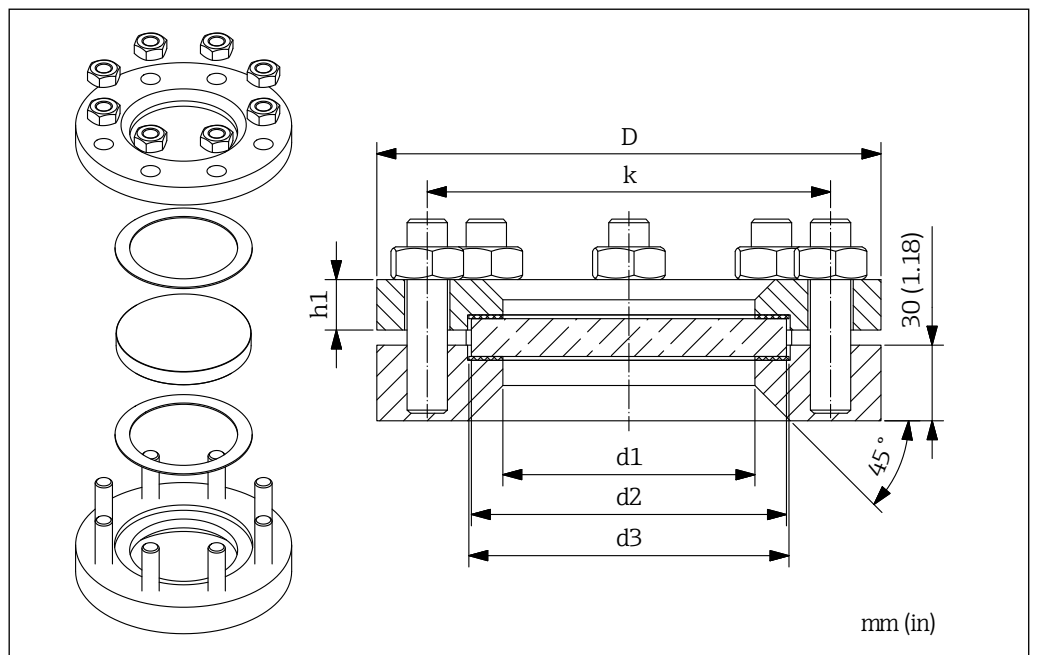

31 Dimensions of sight glass fitting for welding on/in for processes up to 1 MPa

000000043

DN	d1 mm (in)	d2 mm (in)	d3 mm (in)	D mm (in)	k mm (in)	h1 mm (in)
50	80 (3.15)	100 (3.94)	102 (4.02)	165 (6.50)	125 (4.92)	16 (0.63)
80	100 (3.94)	125 (4.92)	127 (5.00)	200 (7.87)	160 (6.30)	20 (0.79)
100	125 (4.92)	150 (5.91)	152 (5.98)	220 (8.66)	180 (7.09)	22 (0.87)

For mounting on available block flanges or counter flanges (process pressure up to max. 2.5 MPa (25 bar), the following bolt-on sight glass fittings can be used:

- Order No.:
71026449, DN50
71026450, DN80
71026451, DN100
- Material: 316Ti stainless steel, PTFE seal and C4400 (max. +200 °C/+392 °F)
- Weight: DN50 approx. 5.4 kg (11.90 lbs) to DN100 approx. 15.9 kg (35.05 lbs)
- The delivery includes the sight glass fitting incl. seals but does not include mounting screws (type and length are dependent on the structural situation).

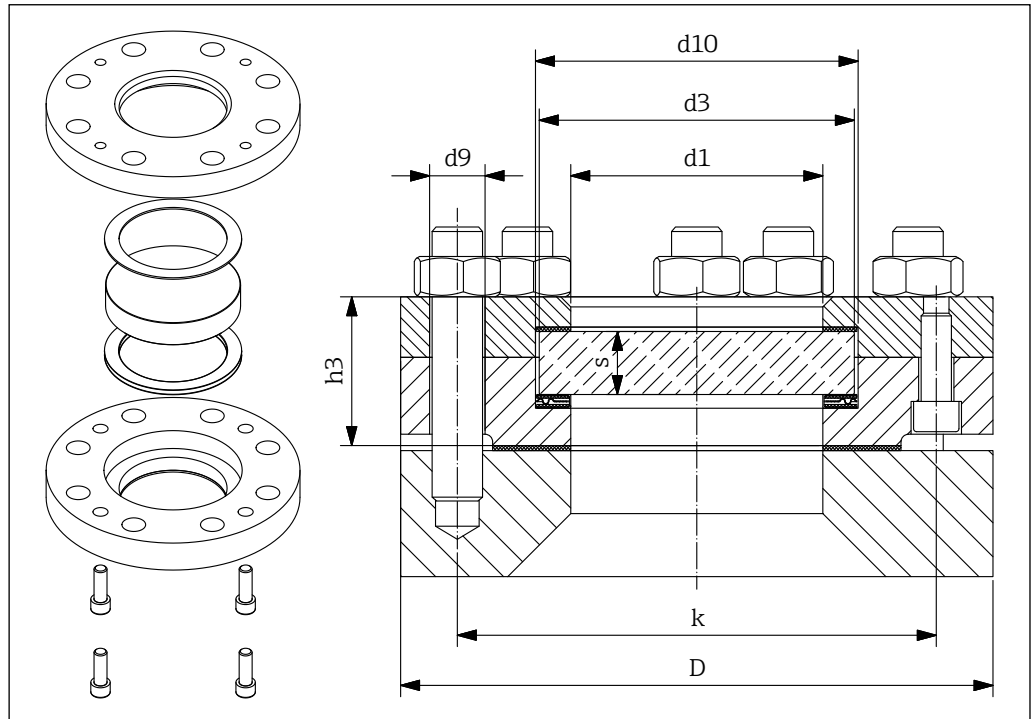

32 Dimensions of sight glass fitting for bolting on for processes up to 2.5 MPa

000000044

DN	d1 mm (in)	d2 mm (in)	s mm (in)	D mm (in)	k mm (in)	h3 mm (in)	d9 mm (in)	d10 mm (in)
50	65 (2.56)	80 (3.15)	15 (0.59)	165 (6.50)	125 (4.92)	41 (1.61)	18 (0.71)	82 (3.23)
80	80 (3.15)	100 (3.94)	20 (0.79)	200 (7.87)	160 (6.30)	50 (1.97)	18 (0.71)	102 (4.02)
100	100 (3.94)	125 (4.92)	25 (0.98)	235 (9.25)	190 (7.48)	59 (2.32)	22 (0.87)	127 (5.00)

Insertion adapter

For mounting on existing process nozzles, insertion adapters of type FAR51 can be used
(→ TI01368F/97/EN):

- Process nozzle DN50 to DN100 PN16 shape A, 2 NPT to 4 NPT 150 lbs RF
- Nozzle lengths: 100 to 300 mm
- Connection thread R 1½, 1½ NPT and G 1½
- Optional with PTFE or aluminum oxide ceramic disc
- Process temperature: Max. -40 to +450 °C (-40 to +842 °F)
- Process pressure: Max. 80 to 510 kPa (0.8 to 5.1 bar) absolute
- Material: 316Ti stainless steel (1.4571)
- Weight: Approx. 5 to 10 kg (11 to 22 lbs)

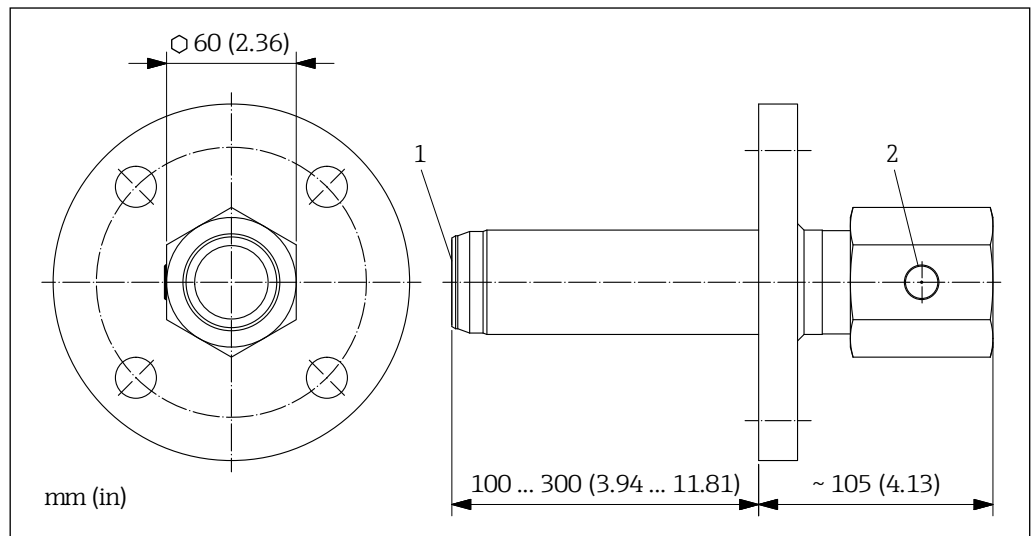

33 Dimensions of plug-in adapters

000000045

- 1 Sealed disc, optional
2 Venting element

Weld-in nozzles

For nozzle mounting, weld-in nozzles of type FAR50 can be used
(→ TI01362F/97/EN):

- Process nozzle DN50 to DN100 PN16 shape A, 2 NPT to 4 NPT 150 lbs RF
- Nozzle lengths: 100 to 300 mm
- Connection thread R 1½, 1½ NPT and G 1½
- With optional PTFE disc
- Process temperature: Max. -40 to +200 °C (-40 to +392 °F)
- Material: 316Ti stainless steel (1.4571)
- Weight: Approx. 6 to 28 kg (13 to 62 lbs)

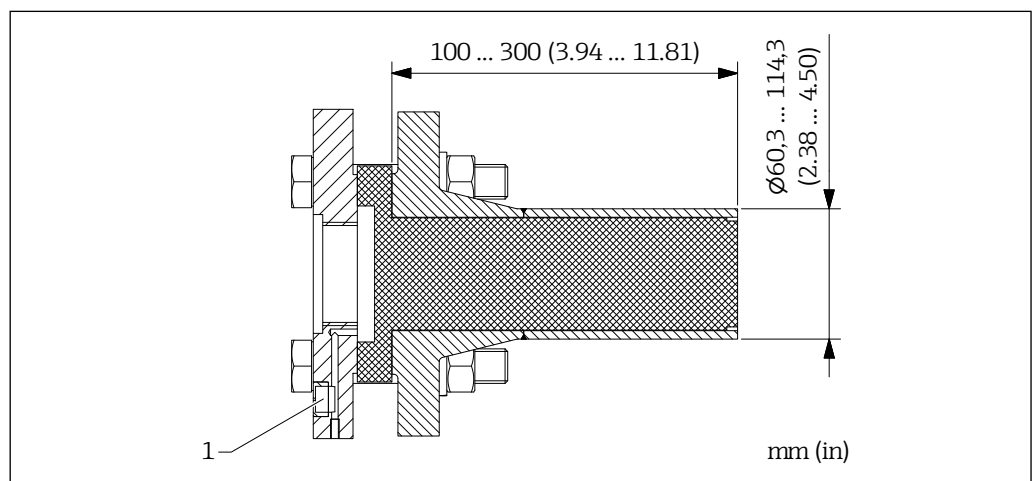

34 Dimensions of weld-in nozzles

000000095

- 1 Venting element

Spacer tube

For mounting in open processes or processes with an internal lining, such as clay, spacer tubes of type FAR53 can be used (→ TI01370F/97/EN):

- Process connection: With or without thread R 2, 2 NPT and G 2
- Pipe lengths: 200 to 2000 mm
- With optional aluminum oxide ceramic disc
- Process temperature: Max. -40 to +450 °C (-40 to +842 °F)
- Material: 316Ti stainless steel (1.4571) or P235GH steel (1.0345)
- Weight: 200 mm approx. 5.3 kg (11.7 lbs) to 2000 mm approx. 22.2 kg (48.9 lbs)

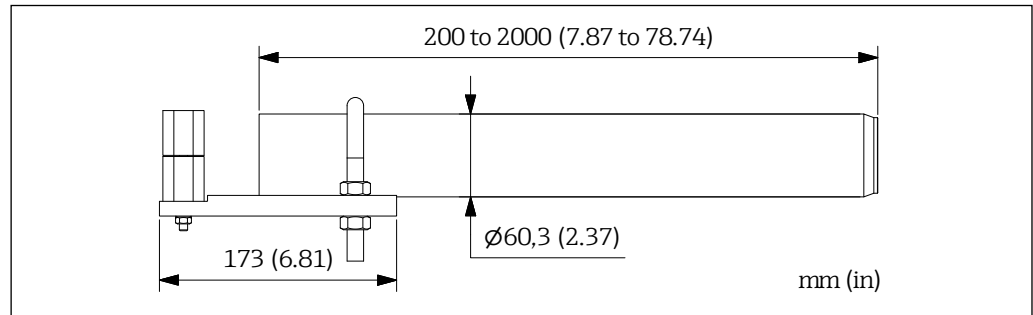

35 Dimensions of spacer tube (wave guide)

000000099

Wave guide

For mounting in structurally restricted installation positions, wave guides of type FAR55 can be used (→ TI01372F/97/EN).

- Process connection: With or without thread R 1½ and 1½ NPT
- Lengths: L1 = 200 to 1500 mm, L2 = 200 to 2000 mm
- Process temperature: Max. -40 to +450 °C (-40 to +842 °F)
- Device connection: Receptacle, suitable for thread R 1½, 1½ NPT and G 1½
- Material: 316Ti stainless steel (1.4571)
- Weight: FAR55-AAAACGAA2* approx. 2.0 kg (4.41 lbs) to FAR55-BAAADGDL2* approx. 17.8 kg (39.24 lbs)

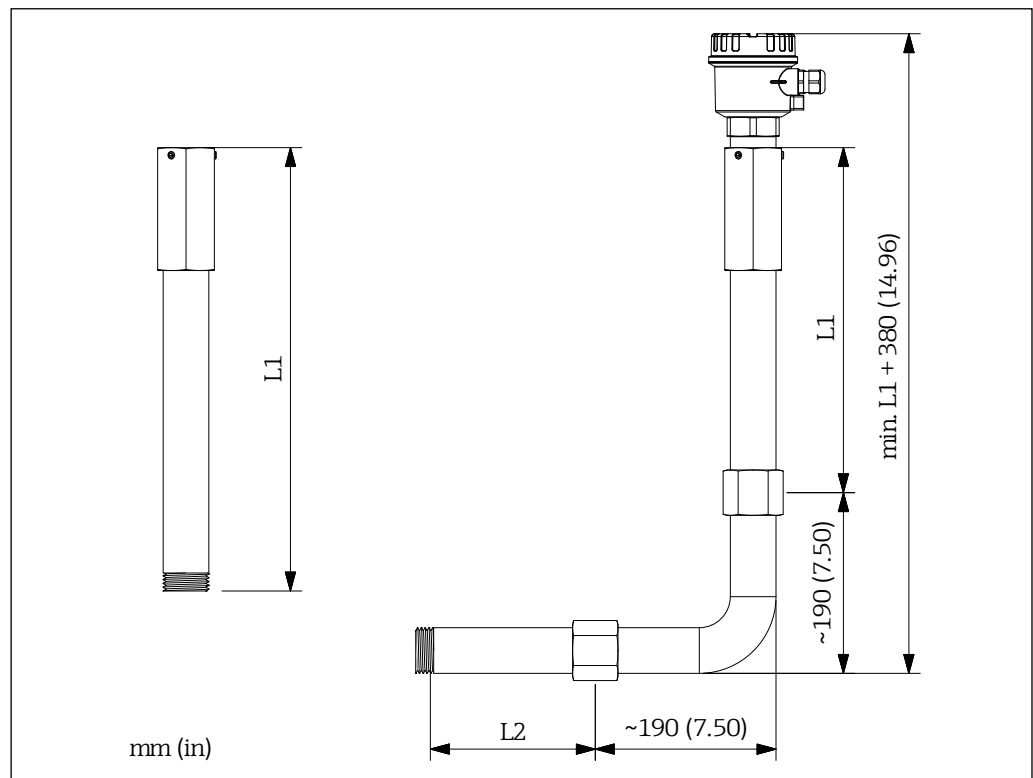

36 Dimensions of wave guide

000000098

High temperature adapter with length extensions

For mounting with connection thread in processes with temperatures up to max. +450 °C (+842 °F), the following high temperature adapters (SW55) and length extensions can be used:

- Order No. (high temperature adapter with flush-mounted ceramic disc and pressure equalization element):

71113441, thread R 1½/Rp 1½ (also suitable for devices with thread ISO 228 G 1½)

71478114, thread R 1½/Rp 1½ (also suitable for devices with thread ISO 228 G 1½), inspection certificate in accordance with EN 10204-3.1

71113449, thread 1½ NPT

71478115, thread 1½ NPT, inspection certificate in accordance with EN 10204-3.1

- Order No. (extension):

71113450, thread R 1½/Rp 1½, L = 225 mm (also suitable for devices with thread ISO 228 G 1½)

71113451, thread R 1½/Rp 1½, L = 325 mm (also suitable for devices with thread ISO 228 G 1½)

71113452, thread R 1½/Rp 1½, L = 525 mm (also suitable for devices with thread ISO 228 G 1½)

71113453, thread 1½ NPT, L = 225 mm

71113454, thread 1½ NPT, L = 325 mm

71113455, thread 1½ NPT, L = 525 mm

- Material: 316Ti stainless steel (1.4571)

- Weight:

- High temperature adapter approx. 1.4 kg (3.09 lbs)

- Extension 225 mm approx. 1.1 kg (2.43 lbs) to 525 mm approx. 2.2 kg (4.85 lbs)

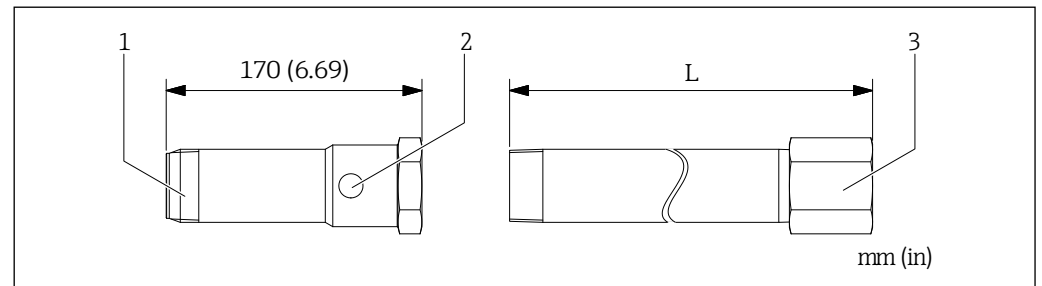

37 Dimensions of high temperature adapter and extensions

0000000046

- 1 High temperature adapter
- 2 Integrated venting element
- 3 Extension

Weather protective cover

For outdoor installation in strong sunlight, the following weather protection cover can be used:

- Order No.: 71454446
- Material: Stainless steel 316L (1.4404)
- Weight: approx. 0.8 kg (1.76 lbs)

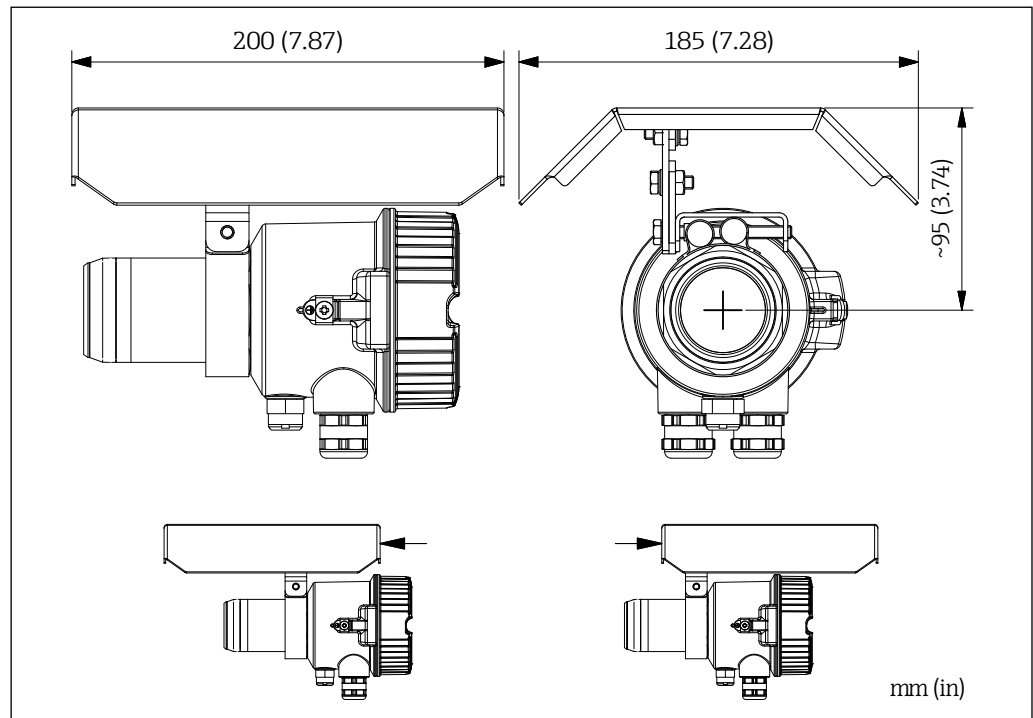

38 Dimensions weather protective cover

000000089

Supplementary documentation

i For an overview of the scope of the associated technical documentation, see the W@M Device Viewer: enter serial number from nameplate (www.endress.com/deviceviewer)

Standard documentation

Operating instructions for Soliwave FDR57/FQR57 microwave barrier
Documentation code: BA01804F/97/A2

Device-dependent supplementary documentation

- Safety instructions ATEX
Documentation code: XA01603F/00/EN
- Safety instructions IECEx
Documentation code: XA01604F/97/EN

www.addresses.endress.com
