

Operating Instructions

SS2100i-2 TDLAS gas analyzer






Table of Contents




1 About this document.....	4		
1.1 Warnings.....	4		
1.2 Symbols on the device.....	4		
1.3 U.S. export compliance	4		
1.4 Standard documentation	4		
2 Introduction	5		
2.1 How to use this manual	5		
2.2 General warnings and cautions	5		
2.3 Manufacturer address	7		
2.4 About the gas analyzers	8		
2.5 Getting familiar with the analyzer	11		
3 Safety.....	23		
3.1 Potential risks affecting personnel	23		
3.2 Explosion hazard	23		
4 Installation.....	24		
4.1 What should be included in the shipping box....	24		
4.2 Lifting/carrying the analyzer	24		
4.3 Inspecting the analyzer	24		
4.4 Hardware and tools for installation	25		
4.5 Mounting the analyzer	25		
4.6 Protective chassis ground connections	25		
4.7 Opening the analyzer enclosure covers	26		
4.8 Cable installation	26		
4.9 Cable glands.....	26		
4.10 Connecting the solenoid valves	27		
4.11 Application of gland lubricant	31		
4.12 Connecting the signals and alarms	32		
4.13 Configuring the RS-232/RS-485 converter.....	34		
4.14 Connecting electrical power to the analyzer.....	35		
4.15 Connecting the gas lines	37		
4.16 Changing the 4-20 mA current loop mode	37		
5 Specifications.....	39		
5.1 Exd accessory conditions of use	40		
6 Maintenance and troubleshooting... 	42		
6.1 Gas leaks	42		
6.2 Excessive sampling gas temperatures and pressures.....	42		
6.3 Electrical noise	42		
6.4 Contamination	43		
6.5 Cleaning the mirrors.....	43		
6.6 Replacing the pressure sensor.....	47		
6.7 Flame arrestor replacement and safety	57		
6.8 Peak tracking reset procedure	60		
6.9 Instrument issues.....	60		
6.10 Service	62		
6.11 Service repair order.....	62		
6.12 Packing, shipping, and storage	62		
6.13 Storage	63		
6.14 Disclaimers	63		
6.15 Warranty.....	63		
7 Analyzer parts	64		
8 Wiring diagrams.....	73		

1 About this document

1.1 Warnings

Structure of Information	Meaning
 WARNING Causes (/consequences) Consequences of non-compliance (if applicable) ▶ Corrective action	This symbol alerts you to a dangerous situation. Failure to avoid the dangerous situation can result in a fatal or serious injury.
 CAUTION Causes (/consequences) Consequences of non-compliance (if applicable) ▶ Corrective action	This symbol alerts you to a dangerous situation. Failure to avoid this situation can result in minor or more serious injuries.
 NOTICE Cause/situation Consequences of non-compliance (if applicable) ▶ Action/note	This symbol alerts you to situations which may result in damage to property.

1.2 Symbols on the device

Symbol	Description
	The Laser Radiation symbol is used to alert the user to the danger of exposure to hazardous visible laser radiation when using the analyzer.
	The High Voltage symbol alerts people to the presence of electric potential large enough to cause injury or damage. In certain industries, high voltage refers to voltage above a certain threshold. Equipment and conductors that carry high voltage warrant special safety requirements and procedures.
	The CE Marking indicates conformity with health, safety, and environmental protection standards for products sold within the European economic area (EEA).

1.3 U.S. export compliance

The policy of Endress+Hauser is strict compliance with U.S. export control laws as detailed on the website of the [Bureau of Industry and Security](#) at the U.S. Department of Commerce.

1.4 Standard documentation

All documentation is available on:

- the USB provided with the analyzer
- Endress+Hauser's website: www.endress.com

Each analyzer shipped from the factory is packaged with documents specific to the model that was purchased. This document is an integral part of the complete document package, which also includes:

Part number	Document type	Description
TI01670C	SS2100i-2 Technical Information	Planning aid for your device. This document contains information for the analyzer including system design with sample conditioning components and inlet/outlet points, certificates and approvals, and product technical data.
XA02694C	SS2100i-2 Safety Instructions	Requirements for installing or operating the SS2100i-2 TDLAS Gas Analyzer related to personnel or equipment safety.
GPO1180C	Description of Device Parameters (NS 5.14)	Provides the user with an overview of the NS 5.14 firmware functionality.

For additional instruction manuals, refer to the Endress+Hauser website to download the published documentation: www.endress.com.

2 Introduction

Endress+Hauser SS2100i-2 products use SpectraSensors TDLAS technology and are high-speed, diode-laser based extractive analyzers designed for extremely reliable monitoring of very low (trace) to standard concentrations of specific components in various background gases. To ensure that the analyzer performs as specified, it is important to closely review the sections of this manual. This manual contains a comprehensive overview of the SS2100i-2 analyzer and step-by-step instructions for:

- Inspecting the analyzer
- Mounting and installing the analyzer
- Troubleshooting the system

2.1 How to use this manual

Take a moment to familiarize yourself with this Operating Instruction by reading the *Table of Contents* → .

Some options and accessories are available for the SS2100i-2 analyzers. This manual addresses the most common options and accessories.

Images, tables, and charts are included to provide a visual understanding of the analyzer and its functions. Special symbols are used to provide the user with key information regarding the system configuration or operation. Pay close attention to this information.

2.1.1 Who should read this manual

This manual should be read and referenced by anyone installing, operating, or having direct contact with the analyzer.

2.1.2 Conventions used in this manual

In addition to the symbols and instructional information, this manual is created with “hot links” to enable the user to quickly navigate between different sections within the manual. Simply click on the link to navigate to the associated reference.

2.2 General warnings and cautions




Instructional icons are provided in this manual and on the SS2100i-2 unit to alert the user of potential hazards, important information and valuable tips. Following are the symbols and associated warning and caution types to observe when servicing the analyzer. Some of these symbols are provided for instructional purposes only and are not labeled on the system.

2.2.1 Safety warning label

The warning label shown below is affixed to the front side of all analyzer enclosures that contain sample gas.








Hazards may vary by stream composition. One or more of the following conditions may apply.

Symbol	Description
	Flammable. Gases used in the processing of this analyzer may be extremely flammable. Any work in a hazardous area must be carefully controlled to avoid creating any possible ignition sources such as heat, arcing, sparking.
	Toxins. Endress+Hauser analyzers measure a variety of gases, including high-level H ₂ S. Follow all safety protocols governing toxic gases and potential leaks.
	Inhalation. Inhaling toxic gases or fumes may cause physical damage or death.




CAUTION

- ▶ Technicians are expected to follow all safety protocols established by the customer that are necessary for servicing or operating the analyzer. This may include, but is not limited to, lockout/tagout procedures, toxic gas monitoring protocols, personal protective equipment (PPE) requirements, hot work permits and other precautions that address safety concerns related to performing service or operation on process equipment located in hazardous areas.

2.2.2 Equipment labels

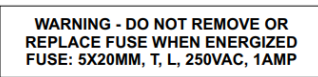
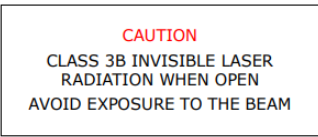




Symbol	Description
	Warning statement for hazardous voltage . Contact may cause electric shock or burn. Turn off and lock out system before servicing.
	Failure to follow all directions may result in damage or malfunction of the analyzer.
	Maximum voltage and current specifications for the fuse closest to label.
	PROTECTIVE EARTH GROUND – Symbol indicates the connection point of the ground wire from the main power source.
	FUNCTIONAL EARTH GROUND – Symbol indicates grounding points intended primarily for troubleshooting.

2.2.3 Instructional symbols

Symbol	Description
	General notes and important information concerning the installation and operation of the analyzer.
	Failure to follow all directions may result in fire.
	INVISIBLE LASER RADIATION – Avoid exposure to beam. Class 3B radiation product. Refer servicing to the manufacturer-qualified personnel.

2.2.4 Special safety symbols used on the equipment

Special safety symbols and labeling are used on the equipment to alert the user to potential hazards and important information associated with the analyzer. Every symbol and label has significant meaning that should be heeded.

Symbol	Description
	ENERGIZED FUSE WARNING – Do not remove or replace fuse when energized.
	INVISIBLE LASER RADIATION – Avoid exposure to beam. Class 3B radiation product. Refer servicing to the manufacturer or qualified personnel.
	DO NOT REMOVE – Removal of the seal or disassembly of pieces traversed by label voids the warranty.
	CLASS 1 LASER PRODUCT – Invisible laser radiation when open. Avoid direct exposure to the beam.
	CLASS 3B LASER PRODUCT – Invisible laser radiation. Avoid direct exposure to beam.
	CLASS 3B LASER WARNING – Class 3B invisible laser radiation when open. Avoid direct exposure to the beam.

2.3 Manufacturer address

Endress+Hauser
 11027 Arrow Route
 Rancho Cucamonga, CA 91730
 United States
www.endress.com

2.4 About the gas analyzers

Endress+Hauser SS2100i-2 analyzers employ SpectraSensors tunable diode laser absorption spectroscopy (TDLAS) to measure the concentration of single compounds in gas mixtures. The tunable diode laser (TDL) absorption spectrometers in the SS2100i-2 operate in the near- to short-wavelength infrared. Each compact sensor consists of a TDL light source, sample cell, and detector configured for high sensitivity measurement of a particular component within the gas-phase constituents in the stream. The sensor is controlled by microprocessor-based electronics with embedded software that incorporates advanced operational and data processing algorithms.

In its simplest form, a diode laser absorption spectrometer typically consists of a sample cell with a mirror at one end, and a mirror or window at the opposite end, through which the laser beam can pass, as shown in the figure below. The laser beam enters the cell and reflects off the mirror(s) making one or more trips through the sample gas and eventually exiting the cell where the remaining beam intensity is measured by a detector. With the SS2100i-2 analyzers, sample gas flows continuously through the sample cell ensuring that the sample is always representative of the flow in the main pipe.



A0055701

Figure 1. Schematic of a typical tunable diode laser absorption spectrometer

#	Description
1	Laser
2	Pressure sensor
3	Outlet
4	Optical head
5	Detector
6	Window/near mirror

#	Description
7.	Inlet
8.	Far mirror

Due to their inherent structure, the molecules in the sample gas each have characteristic natural frequencies (or resonances). When the output of the laser is tuned to one of those natural frequencies, the molecules with that resonance absorb energy from the incident beam. That is, as the beam of incident intensity, $I_0(\lambda)$, passes through the sample, attenuation occurs via absorption by the trace gas with absorption cross section $\sigma(\lambda)$. According to the Beer-Lambert absorption law, the intensity remaining, $I(\lambda)$, as measured by the detector at the end of the beam path of length l (cell length x number of passes), is given by

$$I(\lambda) = I_0(\lambda)\exp [-\sigma(\lambda)lN]$$

where N represents the species concentration. Thus, the ratio of the absorption measured when the laser is tuned on-resonance versus off-resonance is directly proportional to the number of molecules of that species in the beam path, or

$$N = \frac{-1}{\sigma(\lambda)l} \ln \left[\frac{I(\lambda)}{I_0(\lambda)} \right]$$

The figure below shows the typical raw data from a laser absorption spectrometer scan including the incident laser intensity, $I_0(\lambda)$, and the transmitted intensity, $I(l)$, for a clean system and one with contaminated mirrors (shown to illustrate the system’s relative intensity to mirror contamination).

The positive slope of raw data results from ramping the current to tune the laser, which not only increases the wavelength with current, but also causes the corresponding output power to increase. By normalizing the signal by the incident intensity, any laser output fluctuations are canceled, and a typical, yet more pronounced, absorption profile results, as shown in the figure below.

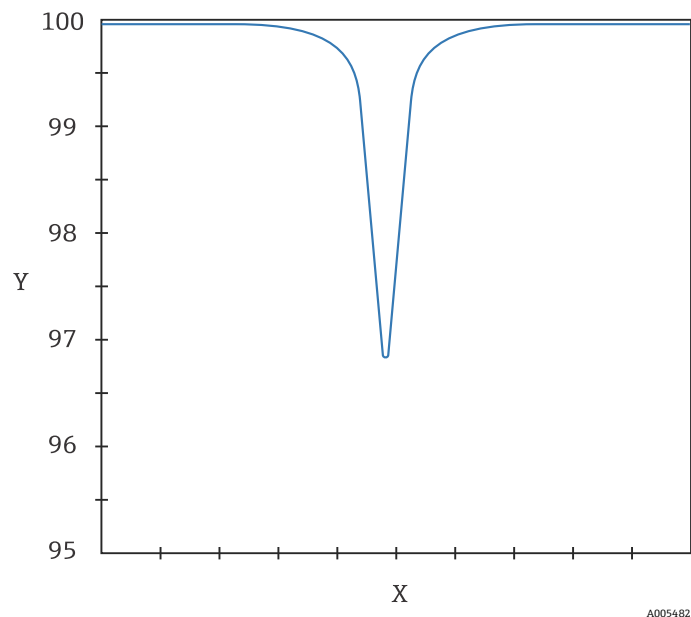


Figure 2. Typical normalized signal from a laser diode absorption spectrometer

Item	Description
X	Wavelength (arbitrary units)
Y	Signal strength (%)

Contamination of the mirrors results solely in lower overall signal. However, by tuning the laser off-resonance as well as on-resonance and normalizing the data, the technique self-calibrates every scan resulting in measurements that are unaffected by mirror contamination.

2.4.1 Differential TDLAS

SpectraSensors differential TDLAS technology involves subtracting two spectrums from one another. A “dry” spectrum, a response from the sample when the analyte of interest has been completely removed, is subtracted from the “wet” spectrum, a response from the sample when the analyte is present. The remainder is a spectrum of the pure analyte. This technology is used for very low or trace measurements and is also useful when the background matrix changes over time.

2.4.2 Wavelength modulation spectroscopy (WMS) signal detection

Endress+Hauser takes the fundamental absorption spectroscopy concept a step further by using a sophisticated signal detection technique called wavelength modulation spectroscopy (WMS). When employing WMS, the laser drive current is modulated with a kHz sine wave as the laser is rapidly tuned. A lock-in amplifier is then used to detect the harmonic component of the signal that is at twice the modulation frequency ($2f$). Refer to the figure below, which is shown in arbitrary units (a.u.). This phase-sensitive detection enables the filtering of low-frequency noise caused by turbulence in the sample gas, temperature and/or pressure fluctuations, low-frequency noise in the laser beam or thermal noise in the detector.

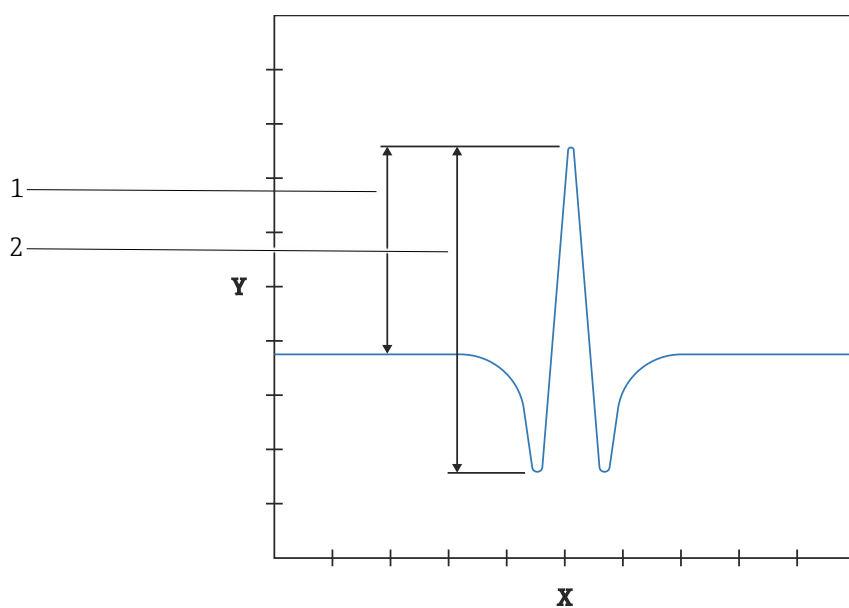


Figure 3. Typical normalized $2f$ signal showing species concentration proportional to height

Item	Description
1	peak height
2	Peak to peak height
X	Axis wavelength (a.u.)
Y	Axis transmission signal (a.u.)

With the resulting low-noise signal and use of fast post-processing algorithms, reliable parts per million (ppm) or parts per billion (ppb) detection levels are possible (depending on target and background species) at real-time response rates.

All Endress+Hauser TDLAS gas analyzers employ the same design and hardware platform. Measuring different trace gases in various mixed hydrocarbon background streams is accomplished by selecting a different optimum diode laser wavelength between 700 to 3000 nm, which provides the least amount of sensitivity to background stream variations.

2.4.3 Sample conditioning system

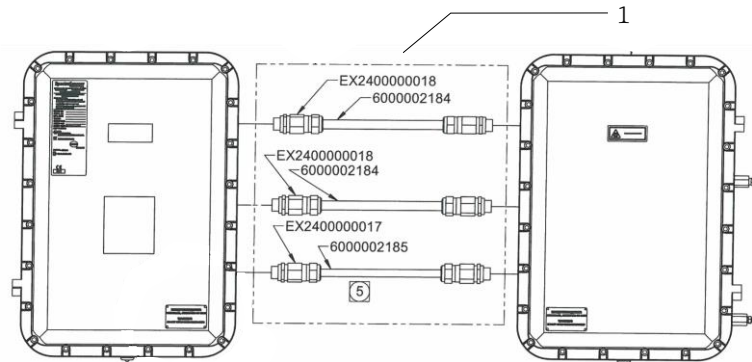
The analyzer may be integrated with a sample conditioning system (SCS) designed to meet the sample condition requirements for the analyzer while preserving sample integrity and minimizing lag time. Refer to the SCS Operating Instructions for more information.

2.4.4 Determining firmware version

When the analyzer is powered on for the first time, the firmware version will display on the system LCD display for approximately seven seconds. Refer to *Powering Up the Analyzer* in the *NS5.14 Firmware Description of Device Parameters (GP01180C)* for this analyzer for operational instructions. The firmware version for each analyzer is also listed on the analyzer calibration certificate.

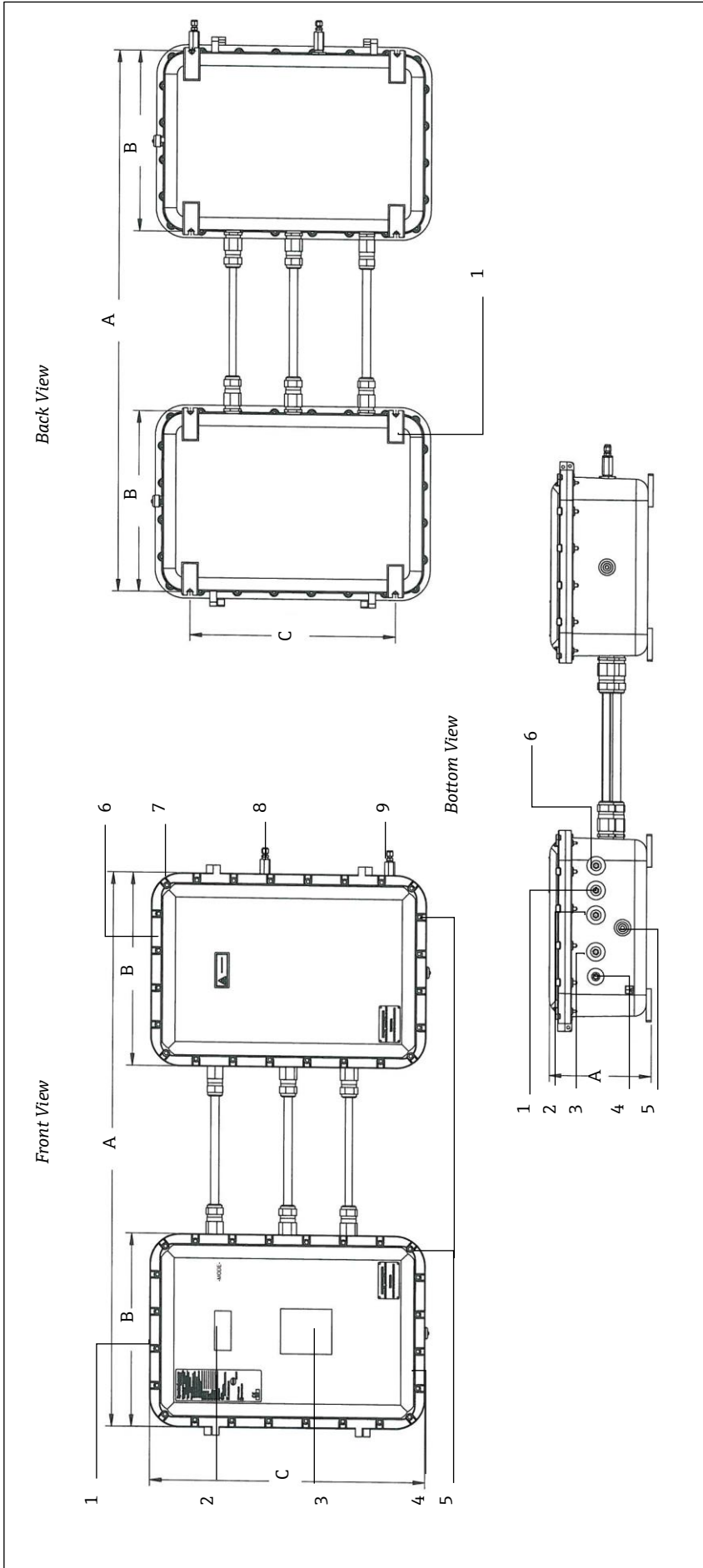
2.5 Getting familiar with the analyzer

The SS2100i-2 analyzer consists of two connected enclosures in a standard cable-coupled configuration, as shown in the figure below.



A0055702

Figure 4. Cable-coupled analyzer configuration using Cable and Gland Kit 1100002143 (1)




A0095703

Figure 5. Dimensions and mounting for electronics and sample cell enclosures (cable-coupled configuration)

- | | | |
|-------------------------------|--------------------------|----------------------------------|
| Front view | Back view | Bottom view |
| 1. Electronics enclosure | 1. 8x mounting feet | 1. M25 4-20 mA output board |
| 2. LCD display | A. 1036.83 mm (40.82 in) | 2. M25 digital input/output port |
| 3. Keypad window | B. 439.93 mm (17.32 in) | 3. M25 solenoid valve port |
| 4. Chassis ground | C. 500.13 mm (19.69 in) | 4. M20 power input port |
| 5. 24x cover screws | | 5. Breather |
| 6. Measurement cell enclosure | | 6. M25 serial com port |
| 7. Chassis ground | | A. 247.90 mm (9.76 in) |
| 8. Gas in | | |
| 9. Gas out | | |
| A. 1066.8 mm (42.0 in) | | |
| B. 469.9 mm (18.5 in) | | |
| C. 670 mm (26.38 in) | | |

NOTICE

- ▶ See *Figure 6. Components in SS2100i-2 electronics enclosure* →  for locating fuses. If you need to replace a fuse, use only the same type and rating of fuse as the original. The types and ratings are listed in the following tables.

In the sample cell enclosure, the sample cell is the actual TDLAS spectrometer through which the gas sample flows. The sample cell is equipped with a pressure sensor and thermistor to monitor the thermodynamic conditions of the sample. The heater maintains the inside of the analyzer enclosure at a constant temperature with air circulated by the fan.

Fuse specifications for AC 240 V systems

Drawing Reference	Description	Rating
F3	Miniature Fuse, 5 x 20 mm, Time Delay	AC 250 V / 1.6 A
F4 ¹	Miniature Fuse, 5 x 20 mm, Time Delay	AC 250 V / 0.5 A
F5 ¹⁴¹ , F6 ¹ , F7 ¹ , F8 ¹	Miniature Fuse, 5 x 20 mm, Time Delay	AC 250 V / 0.1 A
F9 ¹	Miniature Fuse, 5 x 20 mm, Time Delay	AC 250 V / 1.0 A
F10 ¹	Miniature Fuse, 5 x 20 mm, Time Delay	AC 250 V / 1.2 A

Fuse specifications for AC 120 V systems

Drawing Reference	Description	Rating
F3	Miniature Fuse, 5 x 20 mm, Time Delay	AC 250 V / 1.6 A
F4 ¹	Miniature Fuse, 5 x 20 mm, Time Delay	AC 250 V / 0.5 A
F5 ¹⁴¹ , F6 ¹ , F7 ¹ , F8 ¹	Miniature Fuse, 5 x 20 mm, Time Delay	AC 250 V / 0.1 A
F9 ¹	Miniature Fuse, 5 x 20 mm, Time Delay	AC 250 V / 1.0 A
F10 ¹	Miniature Fuse, 5 x 20 mm, Time Delay	AC 250 V / 2.0 A

¹ Housed in fuse terminal blocks. Illuminated LED indicates blown fuse.

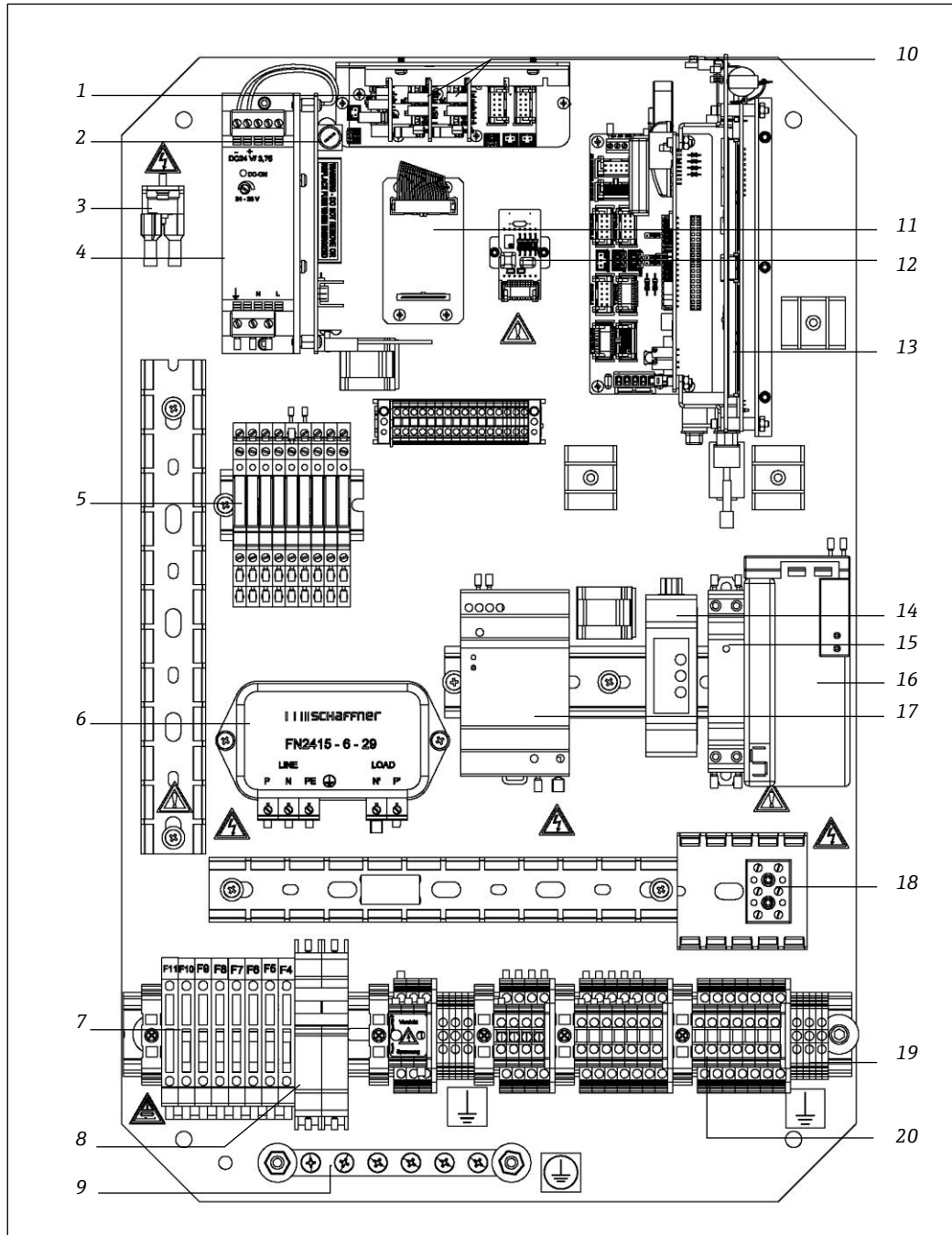


Figure 6. Components in SS2100i-2 electronics enclosure

A0055704

- | | |
|--------------------------------------|--|
| 1. 4-20mA AI board | 11. Relay control board |
| 2. Fuse (F3) | 12. Temperature control board |
| 3. High temperature limit thermostat | 13. ARM9 control electronics |
| 4. Analyzer power supply | 14. RS-232 to RS-422/485 converter |
| 5. Relays | 15. Solid-state relay |
| 6. AC line filter | 16. Temperature controller |
| 7. Fuses (F4-F10) | 17. Auxiliary power supply |
| 8. Main circuit breaker | 18. AC terminal block for sample cell heater |
| 9. Ground bus bar | 19. Ground terminal blocks |
| 10. 4-20mA AO board | 20. Terminal blocks |

The left enclosure (electronics enclosure) contains the control electronics and input/output electrical connections, as shown below. The right enclosure (sample cell enclosure) contains the sample cell and heater, as shown in the figure below.

The keypad and LCD display on the cover of the electronics enclosure are the user interface to the analyzer. Power and signal connections are made via access ports on the bottom of the electronics enclosure. Tube fittings on the right side of the sample cell enclosure are for sample supply and return connections. Both enclosures are mounted on a Unistrut® frame.

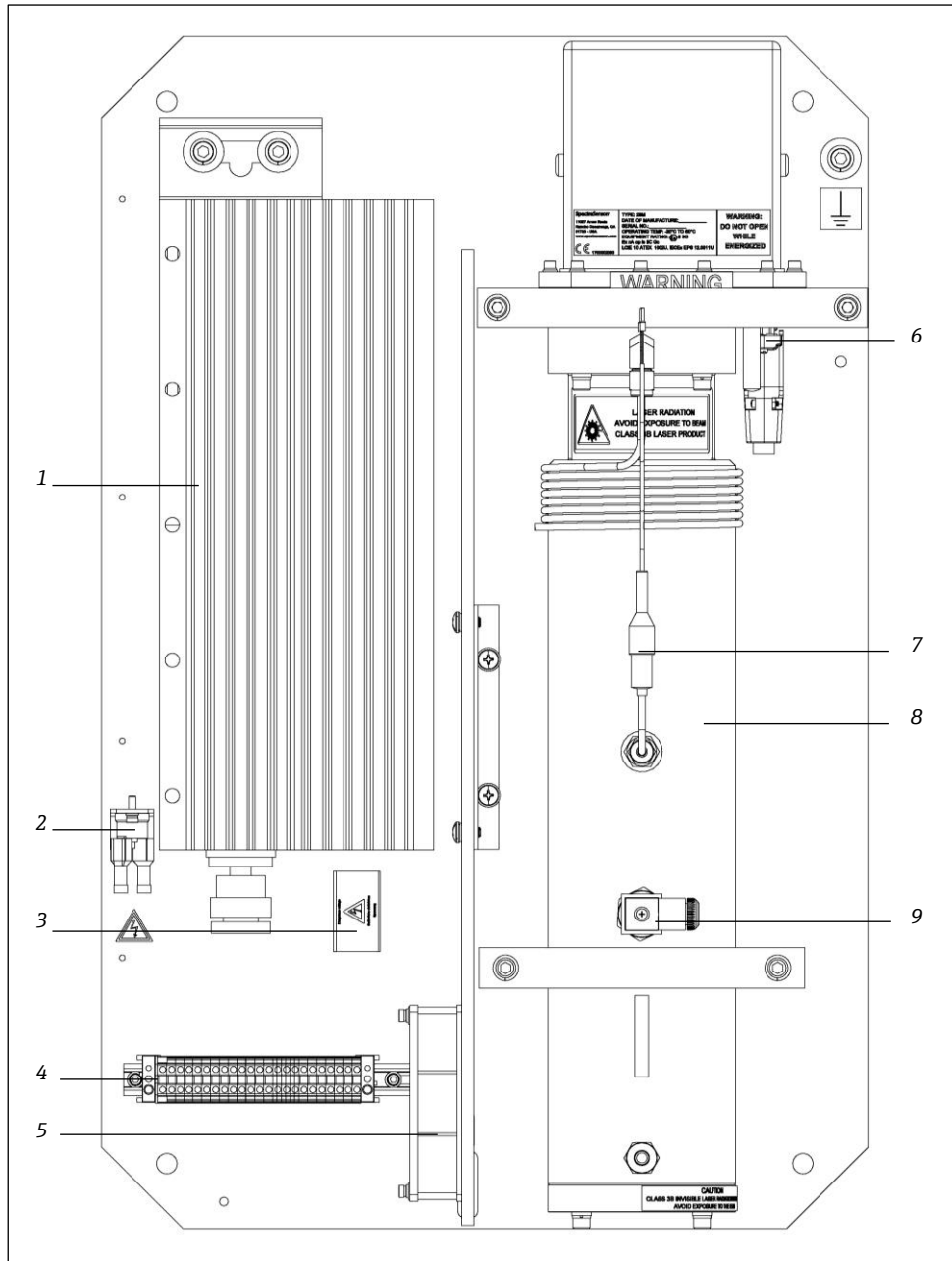


Figure 7. Components on an 8 or 28 m sample cell panel enclosure

A0055705

- | | |
|---|----------------------------------|
| 1. Heater | 6. Transition plate thermistor |
| 2. High temp. limit thermostat set at 70 °C | 7. Sample temperature thermistor |
| 3. AC terminal block for heater | 8. Measurement cell |
| 4. Terminal blocks | 9. Pressure sensor |
| 5. Fan | |

The left enclosure (electronics enclosure) contains the control electronics and input/output electrical connections, as shown below. The right enclosure (sample cell enclosure) contains the sample cell and heater, as shown in the figure below.

The keypad and LCD display on the cover of the electronics enclosure are the user interface to the analyzer. Power and signal connections are made via access ports on the bottom of the electronics enclosure. Tube fittings on the right side of the sample cell enclosure are for sample supply and return connections. Both enclosures are mounted on a Unistrut® frame.

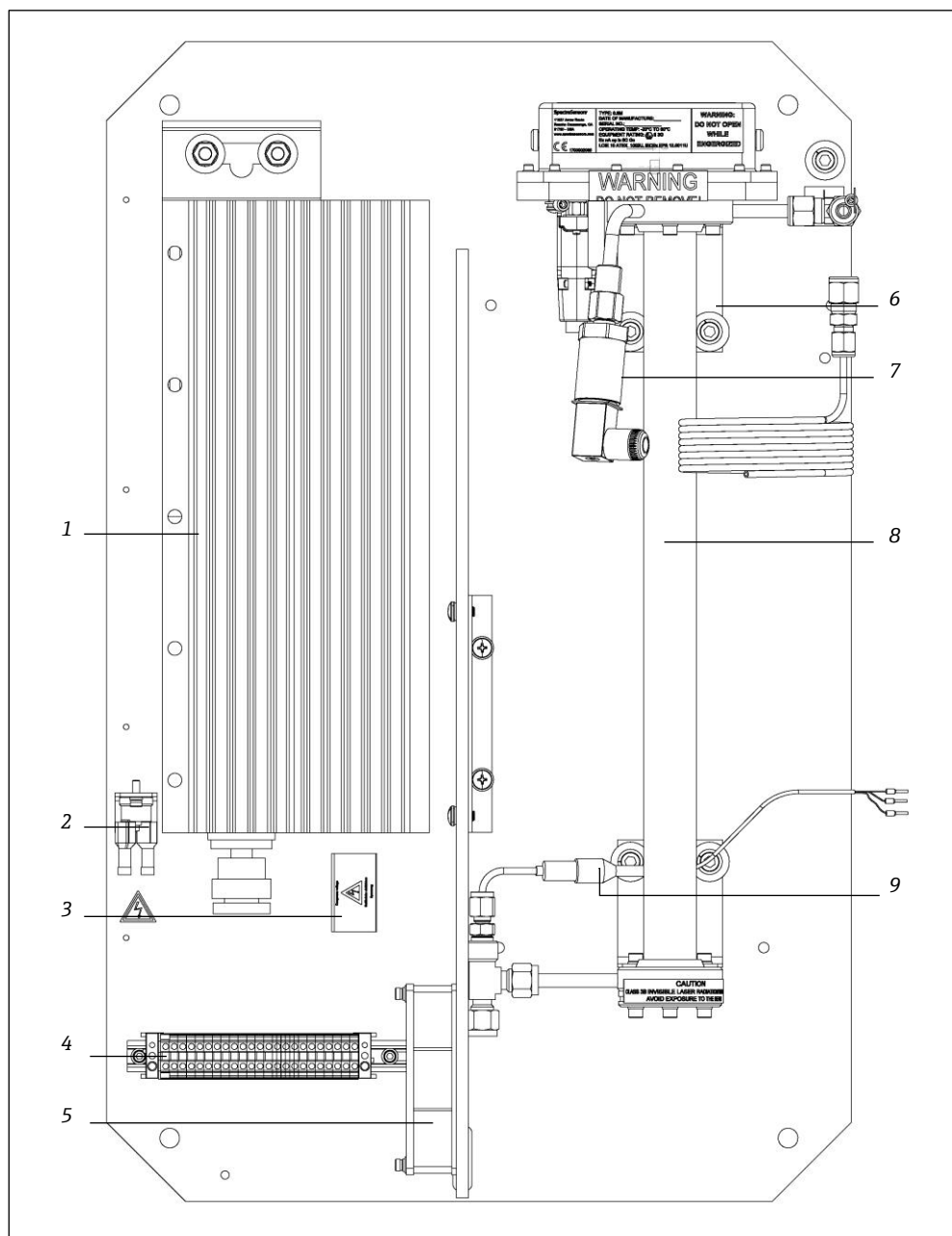


Figure 8. Components on a 0.8 m sample cell panel assembly

A0055706

- | | |
|---|----------------------------------|
| 1. Heater | 6. Transition plate thermistor |
| 2. High temp. limit thermostat set at 70 °C | 7. Pressure sensor |
| 3. AC terminal block for heater | 8. Measurement cell |
| 4. Terminal blocks | 9. Sample temperature thermistor |
| 5. Fan | |

The left enclosure (electronics enclosure) contains the control electronics and input/output electrical connections, as shown below. The right enclosure (sample cell enclosure) contains the sample cell and heater, as shown in the figure below.

The keypad and LCD display on the cover of the electronics enclosure are the user interface to the analyzer. Power and signal connections are made via access ports on the bottom of the electronics enclosure. Tube fittings on the right side of the sample cell enclosure are for sample supply and return connections. Both enclosures are mounted on a Unistrut® frame.

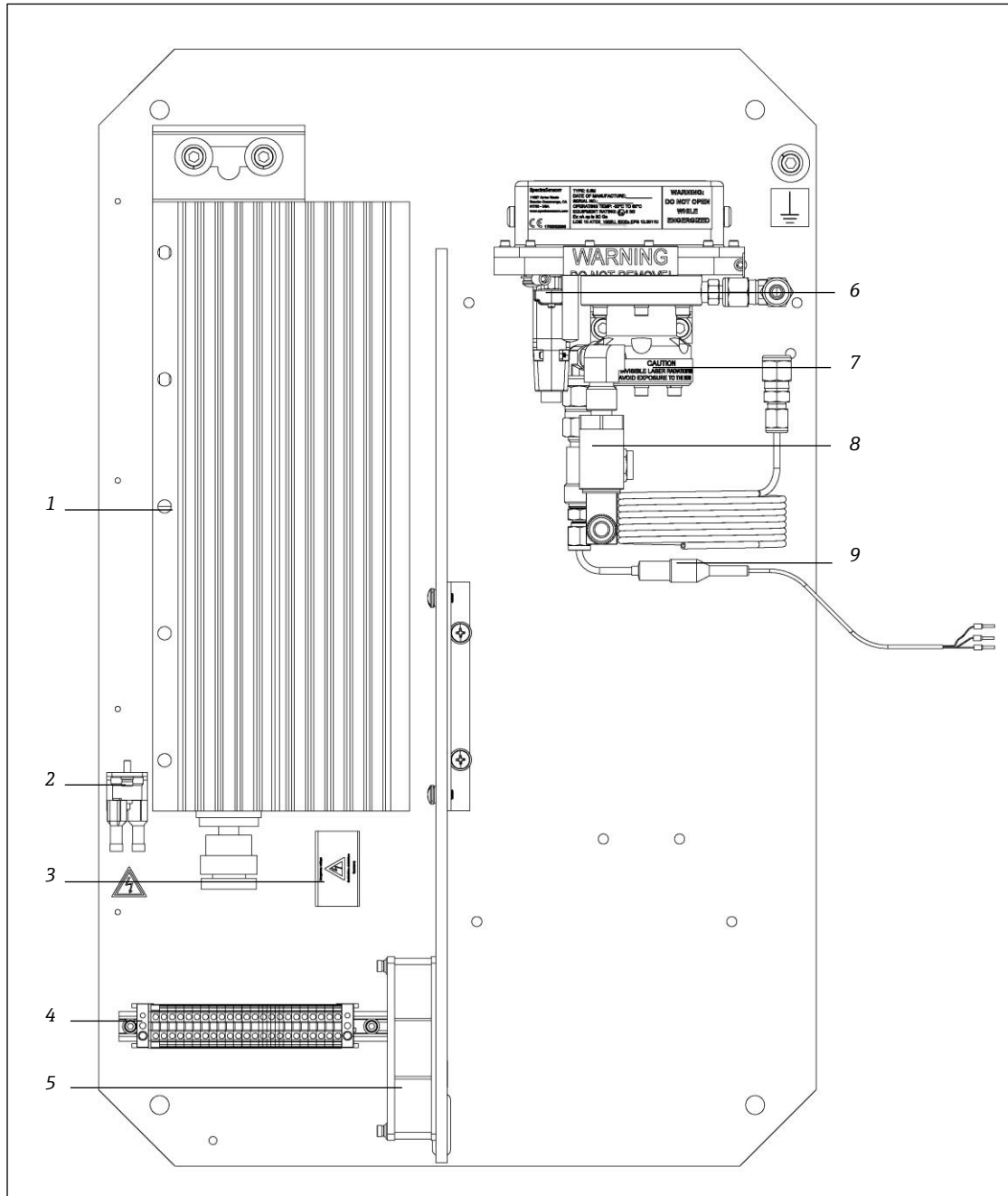


Figure 9. Components on a 0.1 sample cell panel enclosure

A0055707

- | | |
|---|----------------------------------|
| 1. Heater | 6. Transition plate thermistor |
| 2. High temp. limit thermostat set at 70 °C | 7. Measurement cell |
| 3. AC terminal block for heater | 8. Pressure sensor |
| 4. Terminal blocks | 9. Sample temperature thermistor |
| 5. Fan | |

In the electronics enclosure, the analyzer power supply provides power to the analyzer control electronics and relays controlling valves. The analyzer control electronics drive the laser, collect the signal and analyze the spectra.

Powered relays control valves while unpowered relays serve as alarm contacts. An AC line filter is used to condition the input power.

The auxiliary switch-mode power supply provides power to the heater temperature controller and the RS-232/RS-485 converter. The power supply is rated for 1.3 A at DC 24 V output at ambient temperatures $T_a \leq 60\text{ }^\circ\text{C}$ (140 °F). The operational state is indicated by LEDs on the front face, where green means the output voltage is on and within specification, and red means the output voltage is on but below specification.

The thermostat prevents the temperature inside the enclosure from getting too hot. The thermostat is preset at the factory to open the power circuit if the temperature inside the analyzer enclosure exceeds $70 \pm 4\text{ }^\circ\text{C}$ (39.2 °F). The power circuit remains open until the manual reset button (located between the two wire terminals) on the thermostat is pressed or the temperature drops approximately 30% below the set-point.

A DIN rail near the bottom holds fuse terminal blocks, the main breaker, and terminal blocks for all external connections. The temperature controller controls the heater in the sample cell enclosure via the solid-state relay.

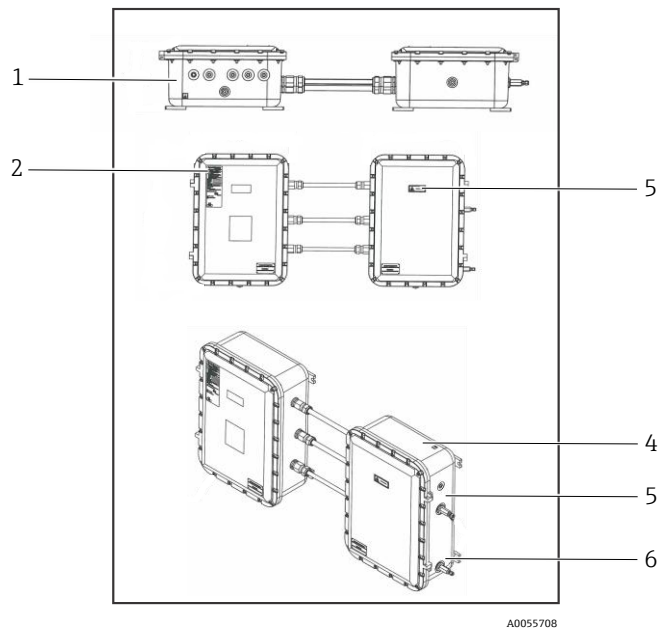


Figure 10. Label placement on exterior of enclosures

- 1. Chassis ground label
- 2. Manufacturer label
- 3. Class 1 laser product label

- 4. Chassis ground label
- 5. Port label

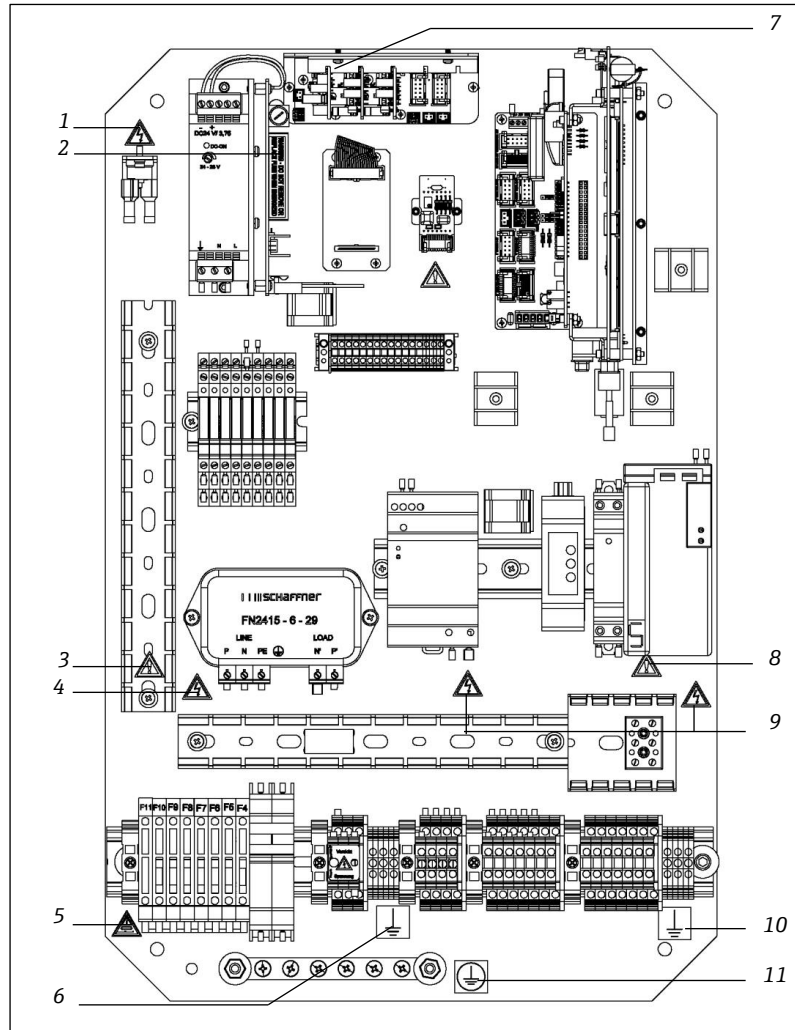


Figure 11. Label placement on electronics panel assembly

A0055709

- | | |
|---|---|
| <ul style="list-style-type: none"> 1. Electric shock warning label 2. Energized fuse warning label 3. General warning label 4. Electric shock warning label 5. Fuse rating label | <ul style="list-style-type: none"> 6. Functional ground earth label 7-8. General warning label 9. Electric shock warning label 10. Functional earth ground label 11. Protective earth ground label |
|---|---|

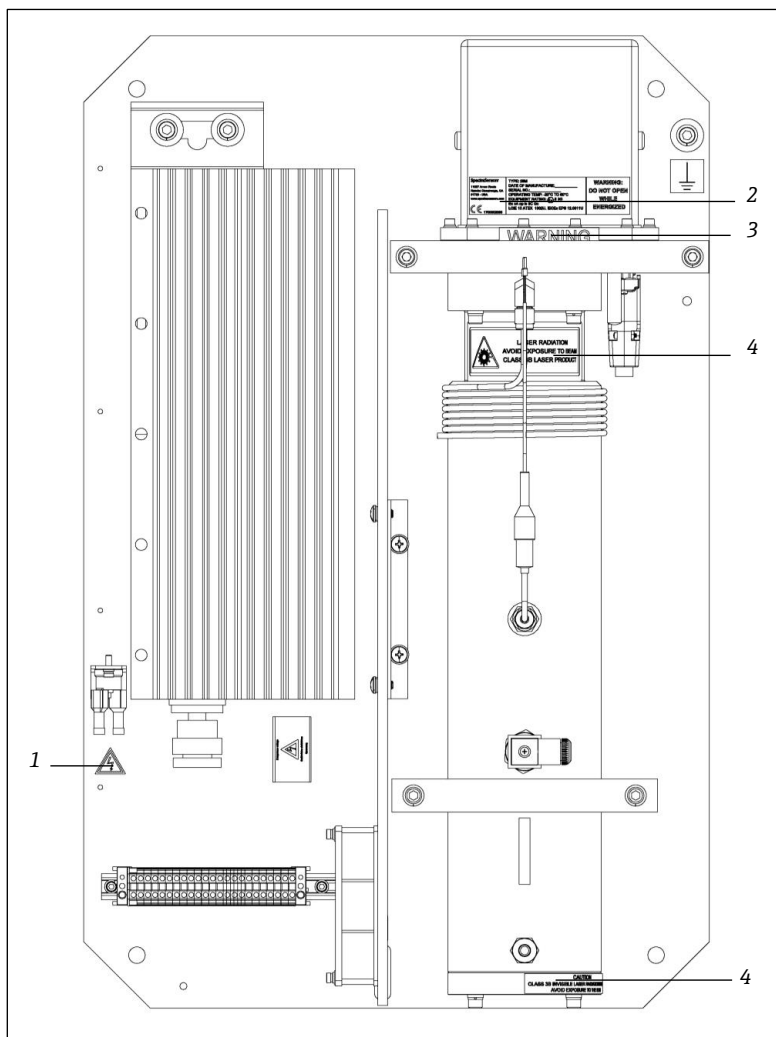


Figure 12. Label placement on 8 and 28 m sample cell panel

A0055705

- 1. Electric shock warning label
- 2. Measurement cell rating label
- 3. Do not remove warning label

- 4. Class 3-B laser product label
- 5. Class 3-B laser warning label

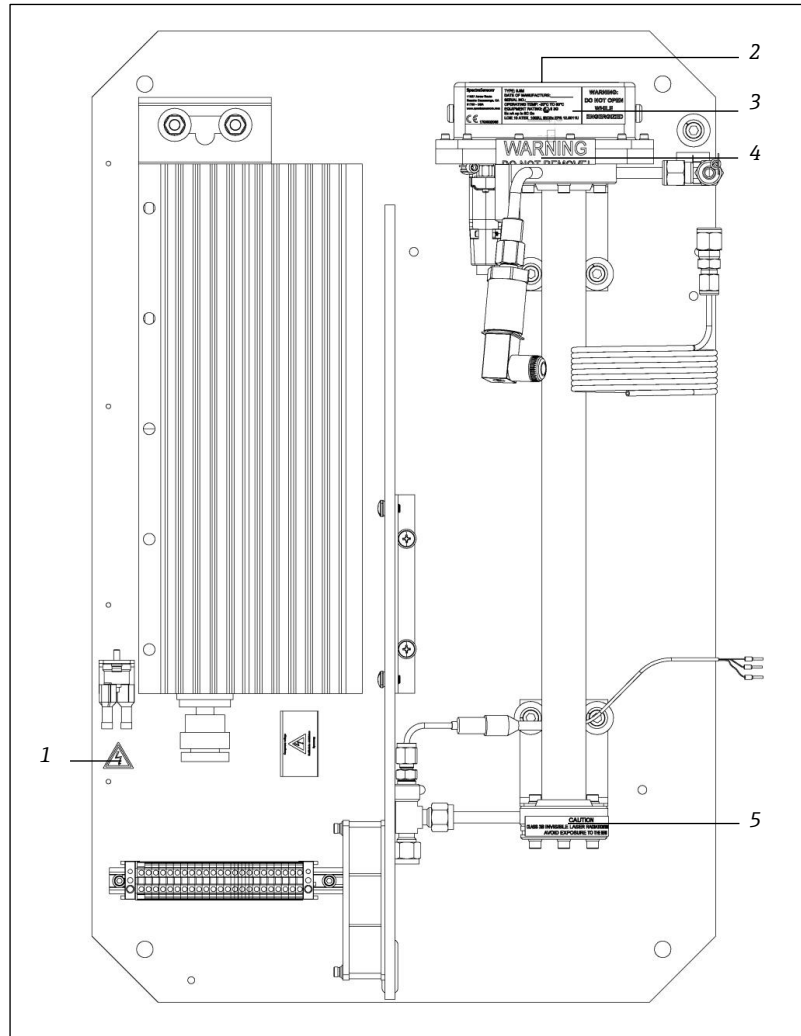


Figure 13. Label placement on 0.8 m sample cell panel

A0055706

- | | |
|----------------------------------|----------------------------------|
| 1. Electric shock warning label | 4. Do not remove warning label |
| 4. Class 3-B laser product label | 5. Class 3-B laser warning label |
| 2. Measurement cell rating label | |

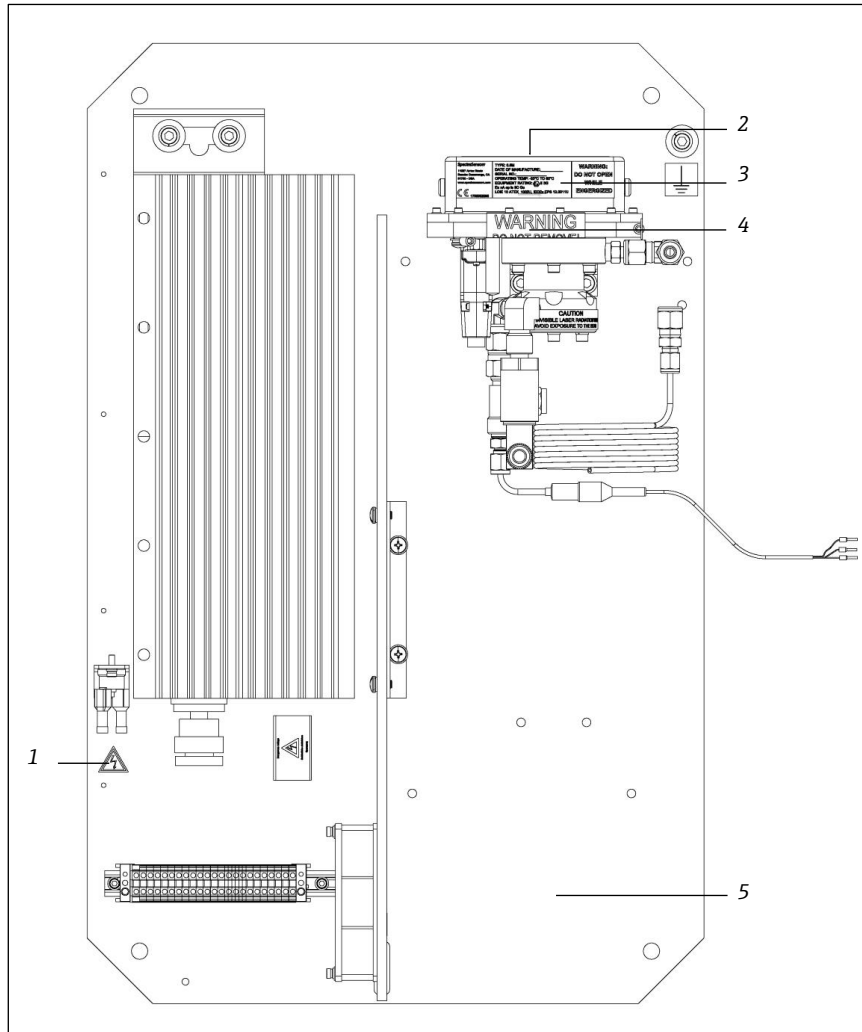


Figure 14. Label placement on sample cell panel assembly (0.1 m sample cell) A0055707

- | | |
|---|--|
| <ul style="list-style-type: none"> 1. Electric shock warning label 2. Class 3-B laser product label | <ul style="list-style-type: none"> 3. Measurement cell rating label 4. Do not remove warning label |
|---|--|

3 Safety

3.1 Potential risks affecting personnel

This section addresses the appropriate actions to take when faced with hazardous situations during or before analyzer service. It is not possible to list all potential hazards within this document. The user is responsible for identifying and mitigating any potential hazards present when servicing the analyzer.

⚠ CAUTION

- ▶ Technicians are expected to follow all safety protocols established by the customer that are necessary for servicing the analyzer. This may include, but is not limited to, lockout/tagout procedures, toxic gas monitoring protocols, PPE requirements, hot work permits and other precautions that address safety concerns related to performing service on process equipment located in hazardous areas.

3.1.1 Mitigating risks

Refer to the instructions for each situation listed below to mitigate associated risks.

Exposure to process gases

1. Shut off the process gas to the analyzer before any service that would require opening a part of the sample plumbing.
2. Purge the system with nitrogen.
3. Shut off the nitrogen purge before opening any part of the sample system.

3.1.2 Exposure to toxic gas (H₂S)

Follow the procedure below if there has been any suspected leak from the sample system and accumulated SCS enclosure.

1. Purge the SCS enclosure to remove any potentially toxic gas.
2. Test the H₂S levels of the SCS enclosure using the port from the safety purge kit to ensure the purge has cleared any toxic gas.
3. If no gas leak is detected, open the SCS enclosure door.

⚠ CAUTION

- ▶ Follow all safety protocols governing toxic gases and potential leaks.

3.1.3 Electrocutation hazard

1. Shut off power at the main disconnect external to the analyzer.

⚠ CAUTION

- ▶ Complete this action before performing any service that requires working near the main input power or disconnecting any wiring or other electrical components.

2. Open enclosure door.

If service must be performed with power engaged (for example, gain adjustment):

1. Note any live electrical components and avoid any contact with them.
2. Only use tools with a safety rating for protection against accidental contact with voltage up to 1000 V (IEC 900, ASTF-F1505-04, VDE 0682/201).

3.2 Explosion hazard

Any work in a hazardous area must be carefully controlled to avoid creating ignition sources such as heat, arcing, or sparking. All tools must be appropriate for the area and hazards present. Electrical connections must not be made or broken with power on to avoid arcing.

4 Installation

This section describes the processes used to initially install and configure your SS2100i-2. Once the analyzer arrives, you should take a few minutes to examine the contents before installing the unit.

4.1 What should be included in the shipping box

The contents of the crate should include:

- The Endress+Hauser SS2100i-2 analyzer
- *SS2100i-2 Safety Instructions (XA02694C)*
- Tooling kit (Material # 70132344)

If any of these contents are missing, contact your sales representative.

4.2 Lifting/carrying the analyzer

The SS2100i-2 is bolted on a Unistrut® (or equivalent) metal frame in the factory. Because of the analyzer's size and weight, use a forklift, pallet jack, or other lifting device to lift or move the analyzer. The weight of the analyzer without the sample conditioning system is approximately 145 kg (320 lb).

Before removing from the crate, move the analyzer as close as possible to the final installation location. Always carry the load using the lifting eyes. Refer to the drawing below for analyzer dimensions.

CAUTION

- ▶ Ensure all equipment used for lifting/moving the analyzer is rated for the maximum weight load.

4.3 Inspecting the analyzer

Unpack and place the unit on a flat surface. Carefully inspect all enclosures for dents, dings, or general damage. Inspect the inlet and outlet connections for damage, such as bent tubing. Report any damage to the carrier.

CAUTION

- ▶ Avoid jolting the instrument by dropping it or banging it against a hard surface, which may disturb the optical alignment.

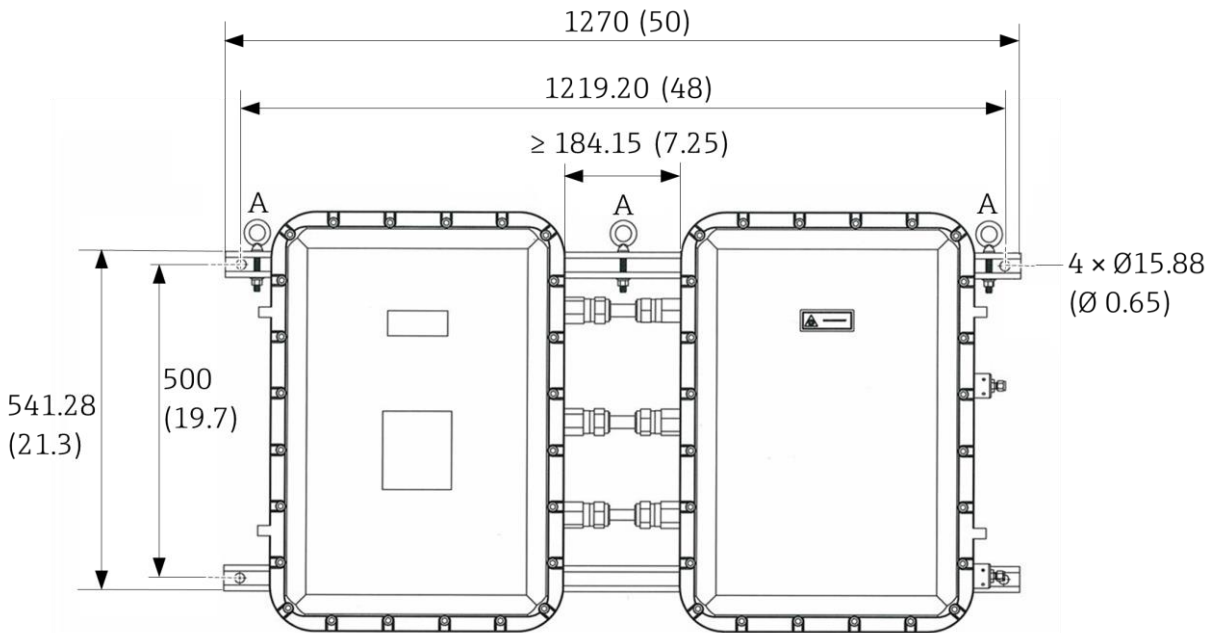


Figure 15. SS2100i-2 mounting and dimensions.

- | | | |
|------------------------------|-----------------------------|----------------------|
| 1. 1270 mm (50 in) | 4. 4 x Ø 15.88 mm (0.65 in) | A. Mounting eyebolts |
| 2. 1219.20 mm (48 in) | 5. 541.28 mm (21.3 in) | |
| 3. 184.15 mm (7.25 in) (min) | 6. 500 mm (19.7 in) | |

4.4 Hardware and tools for installation

Depending on the model, the configuration of accessories, and options ordered, you may need the following specific hardware and tools to complete the installation process.


4.4.1 Hardware

Seamless, stainless steel tubing (electro-plated), 6 mm (¼ in) O.D. x 0.1 mm (0.035 in) is recommended. The SS2100 for trace analytes uses SilcoTek SN2000 coated tubing. SN2000-coated tubes may be used for the sample supply. Coated tubing is not needed for instrument air, nitrogen, or sample return.

4.4.2 Tools

- 8 mm hex key wrench
- 8 mm ball-point hex L-key
- 10 mm ball-point hex L-key
- 9/16 " angled, double open-end wrench – 15 degree and 75 degree
- 11/16 " extra-long, thin-head double open-end wrench
- 7/64 " stainless steel ball point hex L-key
- 5/32 " high torque ball point hex L-key
- RS-485 USB converter (P/N 3100002220)

4.5 Mounting the analyzer

Refer to the layout diagram in *Specifications* →  or the system drawings delivered with the analyzer for mounting dimensions.

NOTICE

- ▶ When mounting the analyzer, position the instrument so that adjacent devices can be operated. Allow 1 m (3.3 ft) of room in front of the analyzer and any switches.

4.5.1 To mount the analyzer

1. Select a suitable location to mount the analyzer. Choose a shaded area or use an optional analyzer hood (or equivalent) to minimize sun exposure.

CAUTION

- ▶ Endress+Hauser analyzers are designed for operation within the specified ambient temperature range. Intense sun exposure in some areas may cause the analyzer temperature to exceed the maximum.

2. Secure all designated attachment points.

Once all designated attachment points are securely fastened, the analyzer should be ready for the electrical connections.


4.6 Protective chassis ground connections

Before connecting any electrical signal or power, the chassis grounds must be connected. Safety requirements for the protective and chassis grounds are as follows:


- The protective and chassis grounds must be of equal or greater size than any other current-carrying conductors, including the heater located in the sample conditioning system.
- The protective and chassis grounds must remain connected until all other wiring is removed.
- If the protective and chassis ground is insulated, it must use the green/yellow color.

WARNING

- ▶ Failure to properly ground the analyzer may create a high-voltage shock hazard.

Refer to *Figure 6. Components in SS2100i-2 electronics enclosure* →  for locations of the chassis ground connections.

To connect the chassis grounds:

1. Connect the chassis ground to the marked upper right corner of the right-side enclosure.
2. Connect the chassis ground to the marked bottom left corner of the left-side enclosure.
3. Connect the system ground to the ground bus bar as shown in *Figure 6. Components in SS2100i-2 electronics enclosure* →  during the electrical power connection.

4.7 Opening the analyzer enclosure covers

⚠ CAUTION

- ▶ Care must be taken to avoid damaging the enclosure cover and body mating surfaces which form a machined flame path (gap ≤ 0.05 mm, roughness ≤ 6 μm). If the surfaces are damaged to the extent they no longer meet the above specifications, please contact your Endress+Hauser service representative. Refer to **Error! Bookmark not defined.****Error! Reference source not found.****Error! Reference source not found.**

4.7.1 To open an analyzer enclosure cover

1. Using an 8 mm hex key wrench or driver, remove each cover screw completely.
2. Place cover screws in a safe place to protect against damage or loss.
3. Gently open cover by pulling on the edge opposite the hinges.

4.8 Cable installation

To avoid potential damage, cable systems and accessories should be installed, so far as practicable, in positions that will prevent them from being exposed to mechanical damage, to corrosion or chemical influences, to the effects of heat and to UV radiation. Refer to the *NS5.14 Firmware Description of Device Parameters (GPO1180C)* for more information.

4.8.1 Terminations

Connections must be made in a manner consistent with the type of terminal and type of protection. Ensure there is not undue stress on the connections.

If multi-stranded and fine-stranded conductors are employed, the ends must be protected against separation of the strands. This can be accomplished by using cable lugs, core-end sleeves, or with the specific terminal type, but not by soldering alone.

NOTICE

- ▶ The creepage distances and clearances must not be reduced by the method in which the conductors are connected to the terminals.

4.9 Cable glands

⚠ CAUTION

- ▶ Certified compound barrier seal type glands and cables must be used where appropriate in compliance with local regulations.


The cable gland must be selected to match the cable diameter. The use of sealing tape, heat-shrink tube or other materials are not permitted to make the cable fit to the cable gland.

If an Ex “d” gland clamping by the sealing ring (compression) is used with braided or armored cable, it must be the type where the braid or armor is terminated in the gland and compression takes place on the inner cable sheath.

⚠ CAUTION

- ▶ For flameproof enclosures, adapters must not be used together with blanking elements.

Flameproof cable glands, adapters or blanking elements, having parallel threads may be fitted with a sealing washer between the entry device and the flameproof enclosure provided that the applicable thread engagement is still achieved after the washer has been fitted. Thread engagement must be at least 5 full threads. Suitable grease may be used if it is non-setting, non-metallic and non-combustible and any earthing between the device and the flameproof

enclosure is maintained. Endress+Hauser recommends using STL8 screw thread lubricant or equivalent on all screw thread and its taped opening. Refer to *Application of gland lubricant* → .

CAUTION

- ▶ Do not use this lubricant on exposed current-carrying parts.

Unused cable entries must be sealed with a flameproof blanking element, which must be fitted directly to the hole (no threaded adapter should be used) and must comply with thread engagement requirements detailed above and must be secured against loosening.

4.10 Connecting the solenoid valves

Differential systems require solenoid valves to switch between process flow and the flow that has been scrubbed of the analyte. The figures referenced below provide additional information about the function and configuration of the solenoid valves.


For more information, refer to *Differential TDLAS* → .

Figure #	Description	Solenoid function	Configuration
16	Basic differential setup for installations where no instrument air is available to drive pneumatic valves.	Solenoids switch the flow directly	2 solenoid valves
17	Preferable setup where only one solenoid is required in favor of more reliable pneumatic valves.	Solenoids switch the flow through instrument air and drive the pneumatic valves	1 solenoid valve 2 pneumatic valves
18	Systems set up for auto-validation with 1 gas	Solenoids switch the flow through instrument air and drive the pneumatic valves	2 solenoid valves 3 pneumatic valves
19	Auto-validation with 2 gases	Solenoids switch the flow through instrument air and drive the pneumatic valves	4 solenoid valves 8 pneumatic valves

For systems performing differential measurements that do not have a factory installed sample system, the cables connecting the solenoid valve(s) to the electronics must be installed. All work should be performed by personnel qualified in electrical installation.



NOTICE

- ▶ Pay special attention to systems measuring especially reactive or adherent species. Because of the reactive or adherent nature of such species, accurate measurement of their concentration may be compromised by adsorption, desorption, or reaction with wetted surfaces. Special coatings are available to minimize these effects.
- ▶ An appropriate sample conditioning system that has been specifically designed to deliver a sample stream that is representative of the process stream at the time of sampling should be used with the system to assure that the analyzer is receiving sample gas that can be correctly measured.

CAUTION

- ▶ Certified compound barrier seal glands and braided armored cables should be used where appropriate in compliance with local regulations.
- ▶ Hazardous voltage and risk of electric shock. Turn off and lock out system power before opening the electronics enclosure and making any connections.
- ▶ Be sure to use solenoid valves rated for the output voltage of the relays on your system. Failure to do so may result in fire.

4.10.1 To connect the solenoid valves

1. Open the analyzer enclosure cover according to the procedure *To open an analyzer enclosure cover* →  to gain access to the field interface terminal block.
2. Install an appropriate compound barrier seal type gland into the M25 access port on the bottom left of the enclosure. Refer to *Application of gland lubricant* → .
3. Pull the solenoid valve cables into the electronics enclosure.

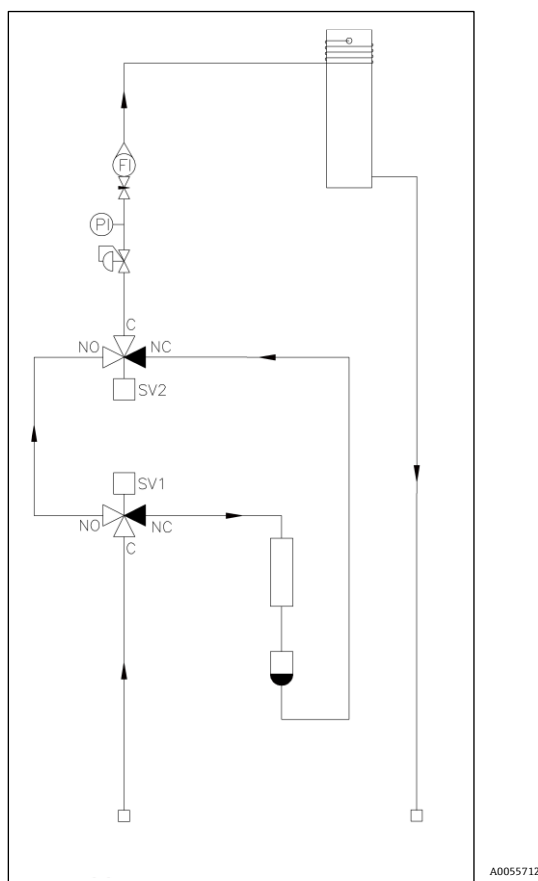


Figure 16. Basic differential system with two solenoid valves

4. Strip back the jacket and insulation of the solenoid valve cables just enough to connect to the appropriate terminals on the field interface terminal block for your particular sample conditioning scheme.

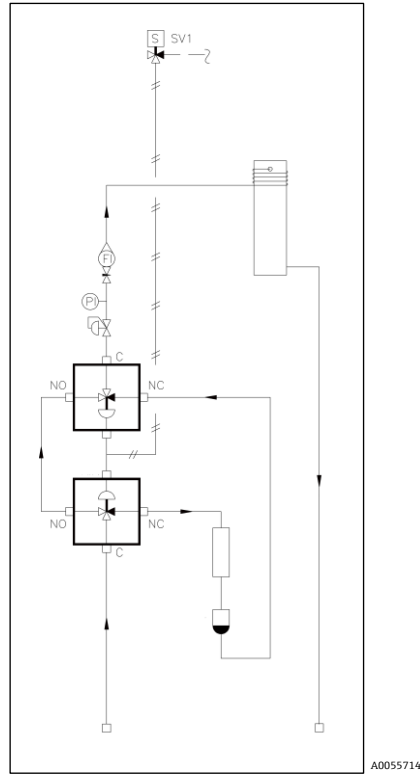


Figure 17. Preferred basic differential system with one solenoid valve driving two pneumatic valves.

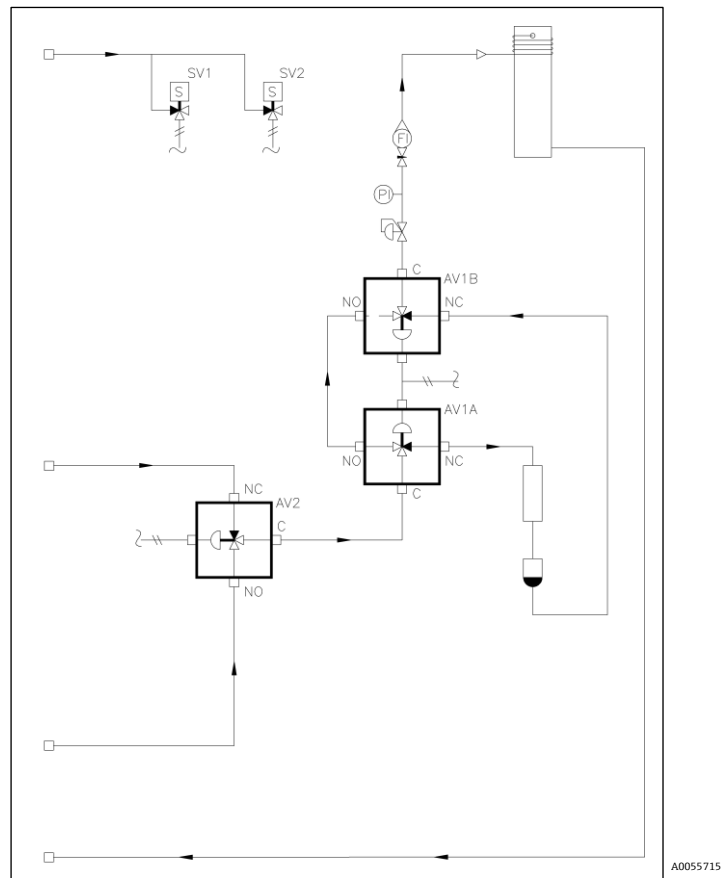


Figure 18. Differential system with single auto-validation requiring two solenoid valves driving three pneumatic valves.

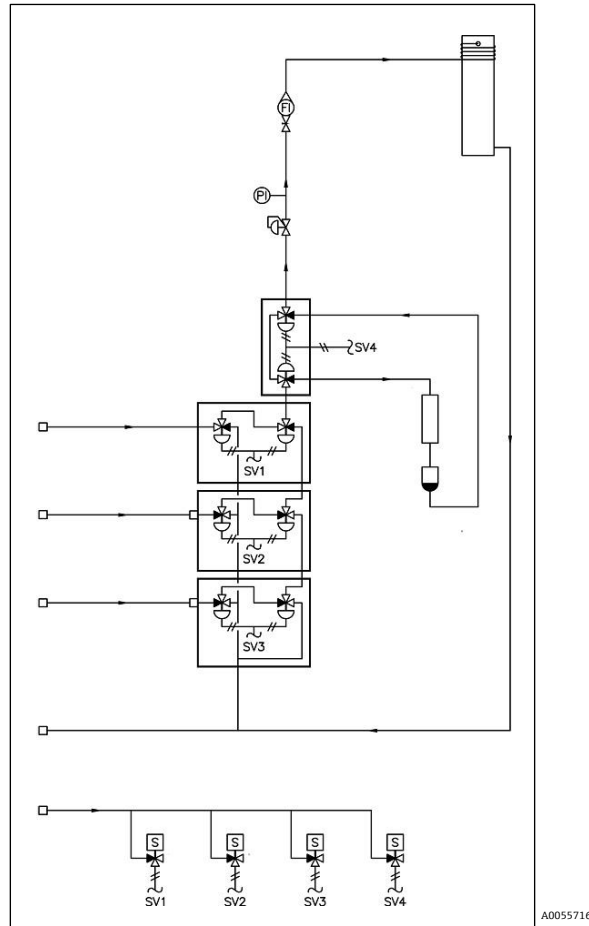


Figure 19. Differential system with dual auto-validation requiring four solenoid valves driving eight pneumatic valves

Terminal block (X2) solenoid valve connections

Fig.	SOV	Description	Terminal	Relay Rating I _{th}
Figure 16	S1	Scrubber Solenoid	1	6A
			2	
	S2	Main/Val Solenoid	3	
			4	
Figure 17	S1	Scrubber Solenoid	1	
			2	
Figure 18	S1	Scrubber Solenoid	1	
			2	
	S2	Val 1 Solenoid	5	
			6	
Figure 19	S1	Scrubber Solenoid	1	
			2	
	S2	Main/Val Solenoid	3	
			4	
	S3	Val 1 Solenoid	5	
			6	
	S4	Val 2 Solenoid	7	
			8	

NOTICE

- ▶ Refer to the schematics in the previous figures for the valve configurations.

5. Verify that each connection is secure.
6. Close the analyzer enclosure cover.

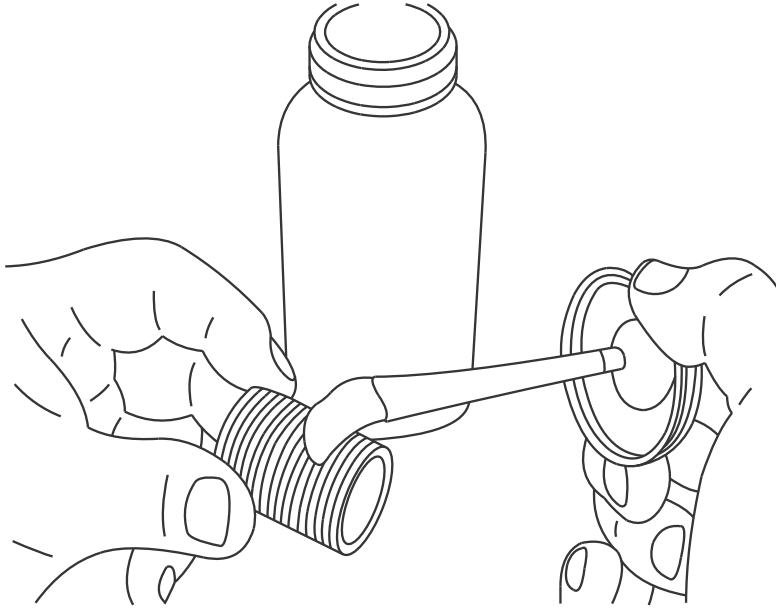
4.11 Application of gland lubricant

To ensure proper installation, Endress+Hauser recommends using STL8 screw thread lubricant or equivalent on all conduit screw thread and its taped opening.

STL8 Screw Thread Lubricant is a lithium based, anti-galling substance with excellent adhesion that maintains rain-tightness and grounding continuity between conduit fittings. This lubricant has proven very effective between parts made of dissimilar metals, and is stable in temperatures from -29 to 149 °C (-20 to 300 °F).

NOTICE

- ▶ Do not use this lubricant on exposed current-carrying parts.
1. Holding the fitting piece at one end, generously apply the lubricant on the male threaded surface (at least 5 threads wide) as shown below.



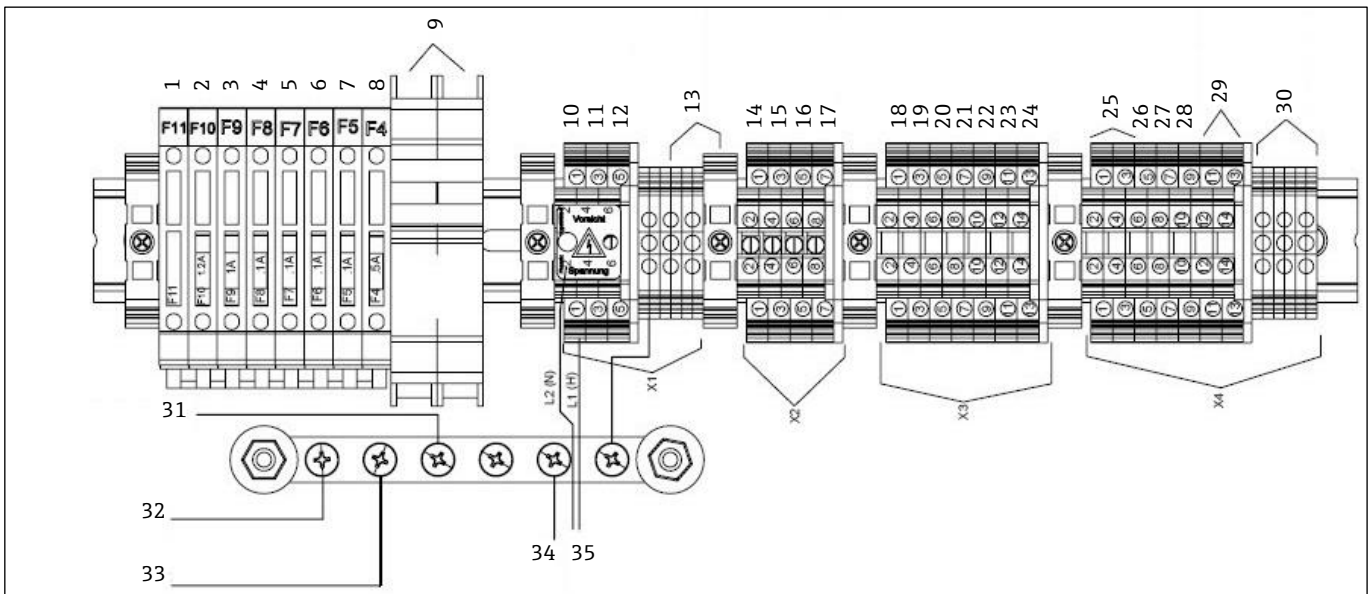
A0054918

Figure 20. Applying conduit lubricant

2. Screw the female pipe thread onto the male fitting until the lubricated threads are engaged.
 - **Eyes:** May cause minor irritation.
 - **Skin:** May cause minor irritation.
 - **Ingestion:** Non-toxic. Ingestion may result in a laxative effect. Ingestion of substantial quantities may cause lithium toxicity.

4.12 Connecting the signals and alarms

The 4-20 mA AI, 4-20 mA AO, serial, and Ethernet outputs are connected to terminal block (X4), as shown in the figure below. In addition, seven digital inputs/outputs connected to SPDT relays through terminal block (X3) are also provided.




A0054917


Figure 21. Field interface terminal block for connection of input power and input/output signals

- | | | | |
|---------------------------------|--|---|---|
| 1. Spare | 12. AC, filter terminal 6 | 21. VAL 1 active to cust. term 7,8 | 29. Ethernet output terminal 11, 12, 13, 14 |
| 2. To temp limit sw heater | 13. Ground terminals | 22. VAL 2 active to customer terminal 9, 10 | 30. 4-20 mA and serial ground |
| 3. To abb power supply (G3) | 14. Scrubber term 1,2 (SV1, SV2) | 23. Flow switch from customer terminal 11, 12 | 31. From enclosure grnd stud |
| 4. To K4-14 | 15. N.O. connection ¹ (N/C) | 24. VAL REQ from customer terminal 13, 14 | 32. From enclosure door grnd |
| 5. To K3-14 | 16. VAL 1 terminal 5,6 | 25. RS-485 output terminal 1,2,3,4 | 33. From heater grnd stud |
| 6. To K2-14 | 17. VAL 2 terminal 7,8 | 26. CH A 4-20 mA output term 5,6 | 34. PE |
| 7. To K1-14 | 18. HI alarm CH2 to customer terminal 1,2 | 27. CH B 4-20 mA output term 7,8 | 35. Incoming power |
| 8. To ABB power supply | 19. General alarm to customer terminal 3,4 | 28. 4-20 mA input terminal 9,10 | |
| 9. To AC filter | 20. VAL fail to customer term 5,6 | | |
| 10. To circuit breaker term 1,2 | | | |
| 11. Heater neutral terminal 4 | | | |

NOTICE

- ▶ The 4-20 mA current loop output is factory set to source current. To change the 4-20 mA current loop output from source to sink, see *To change the 4-20 mA board from source to sink* → .



The relays for the alarms are configured to be fail-safe (or normally energized) so the dry contacts will open in the event of power loss. Thus, the alarms are wired to be normally closed (NC) when the analyzer is running.

Consult the wiring diagrams in *Wiring diagrams* → . All work should be performed by personnel qualified in electrical installation.

CAUTION

- ▶ Certified compound barrier seal glands and cables must be used where appropriate in compliance with local regulations.
- ▶ Hazardous voltage and risk of electric shock. Turn off and lock out system power before opening the electronics enclosure and making any connections.

4.12.1 To connect the signal and alarm cables

1. Open the enclosure cover according to the procedure under *To open an analyzer enclosure cover* →  to gain access to the field interface terminal block.
2. Install appropriate compound barrier or seal type glands into the three M25 access ports on the bottom right of the electronics enclosure. Refer to *Application of gland lubricant* → .
3. Pull the cables for the alarm outputs and validation request input through the first (from left) gland, the cables for the 4-20 mA AI and 4-20 mA AO through the second gland and the cable for serial or Ethernet communication through the third gland and into the enclosure.
4. Strip back the jacket and insulation of the 4 to 20 mA AI, 4 to 20 mA AO and serial or Ethernet cables just enough to connect to the terminals of block (X4).
5. Connect the 4-20 mA AI, 4-20 mA AO, and serial or Ethernet wires to the appropriate terminals. See below.

Terminal block (X4) input/output signal connections

Terminal	Description	D Pin #	Wire Color Cat5(e)
1	Serial Rx or TD-	1	Blue
2	Serial Tx or TD+	2	Brown
3	N/C ²		
4	N/C		
5	4-20 mA AO Ch. A (+)		
6	4-20 mA AO Ch. A (-)		
7	4-20 mA AO Ch. B (+)		
8	4-20 mA AO Ch. B (-)		
9	4-20 mA AI (+)		

¹ N.O. = normally open
² "N/C" means no connection.

Terminal	Description	D Pin #	Wire Color Cat5(e)
10	4-20 mA AI (-)	RJ45 Pin #	Wire Color (T568B) Cat5(e)
11	Ethernet Tx+ (BI_DA+)	1	White/Orange
12	Ethernet Tx- (BI_DA-)	2	Orange
13	Ethernet Rx+ (BI_DB+)	3	White/Green
14	Ethernet Rx- (BI_DB-)	6	Green
G	Serial Shield Ground		
G	4-20 mA Ch. A Shield GND		
G	4-20 mA Ch. B Shield GND		


- Strip back the jacket and insulation of the alarm output and validation request input cables just enough to connect to the terminals of block (X3).
- Connect the alarm output and validation request input wires to the appropriate terminals, as indicated in the table below.


Terminal block (X3) input/output signal connections

Terminal	Description
1	High Concentration Alarm
2	
3	General Fault Alarm
4	
5	Validation Fail Alarm
6	
7	Validation 1 Active
8	
9	Validation 2 Active
10	
11	Future Use
12	
13	Validation Request Input
14	

- Verify that each connection is secure.
- Close the analyzer enclosure cover.
- To complete the connections, connect the other end of the current loop wires to a current loop receiver, the serial or Ethernet to a serial or Ethernet port on a computer, the alarm cables to appropriate alarm monitors and the validation request input to a switch.

4.13 Configuring the RS-232/RS-485 converter

The Optically Isolated RS-232 to RS-485 Converter is configured for 2-wire RS-485. DIP switches on the side of the converter, shown in *Connecting electrical power to the analyzer* → , can be used to set time-out and termination.

Refer to the table *Output signal connections (2-wire RS-485 configuration)* → . With the default setting of 9600 baud, the converter will work for baud rates of 9600 and higher.

4.14 Connecting electrical power to the analyzer

The analyzer is configured for AC 120 or 240 V at 50/60 Hz single phase input. Check the manufacturing data label or the terminal block labels to determine the power input requirements. All work should be performed by personnel qualified in electrical installation.

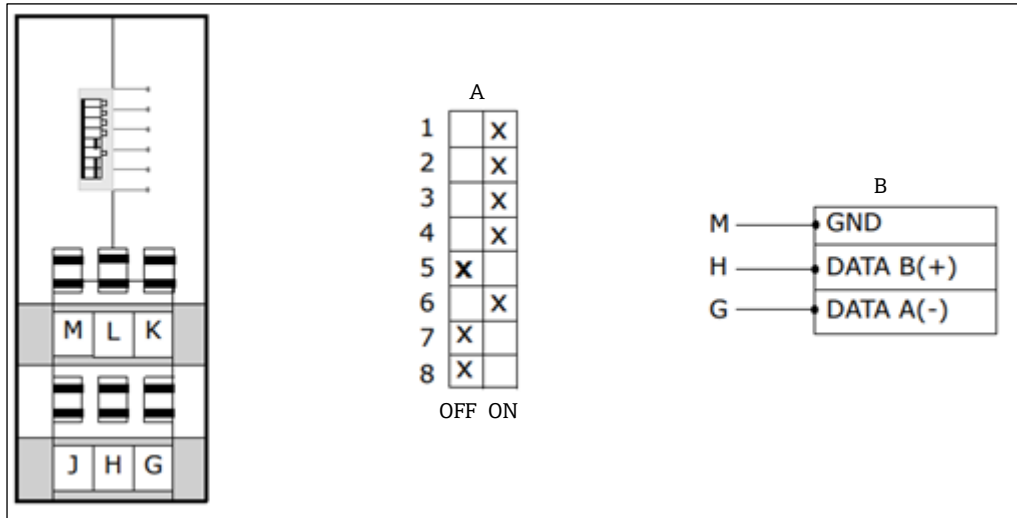


Figure 22. Optically isolated RS-232-to-RS-485 converter DIP switches

- A. Internal termination not used. 9600 Baud, RS-245 two-wire
- B. Cable shield should be grounded.

Output signal connections (2-wire RS-485 configuration)

Item	SW1	SW2	SW3	SW4	SW5	SW6	SW7	SW8	Timeout ¹ (ms)	R11 (KΩ)
RS-485 2-Wire Half Duplex	ON	ON	ON	ON						
120Ω Built-in Termination					ON					
External or no Termination					OFF					
1200 Baud						OFF	OFF	OFF	8.330 ²	820
2400 Baud						OFF	OFF	ON	4.160	
4800 Baud						OFF	ON	OFF	2.080	
9600 Baud						ON	OFF	OFF	1.040	
19.2K Baud						ON	ON	ON	0.580	
38.4K Baud						OFF	OFF	OFF	0.260 ²	27
57.6K Baud						OFF	OFF	OFF	0.176 ²	16
115.2K Baud						OFF	OFF	OFF	0.087 ²	8.2



⚠ WARNING

- ▶ Hazardous voltage and risk of electric shock. Turn off and lock out system power before opening the electronics enclosure and making any connections.

¹ Time-out selections are equal to one character time at the indicated baud rate.

² To achieve this time-out, an appropriate through-hole resistor must be placed in the R11 location on the converter PCB.

CAUTION

- ▶ Certified compound barrier seal type glands and cables must be used where appropriate in compliance with local regulations.
- ▶ See *Figure 6. Components in SS2100i-2 electronics enclosure* →  for locating fuses. If you need to replace a fuse, use only the same type and rating of fuse as the original as shown in the following fuse specifications tables. To re-order parts, refer to *Analyzer parts* → .



Fuse specifications for AC 240 V systems

DWG Ref.	Description	Rating
F3	Miniature Fuse, 5 x 20 mm, Time Delay	AC 250 V / 1.6 A
F4 ¹	Miniature Fuse, 5 x 20 mm, Time Delay	AC 250 V / 0.5 A
F5 ¹ , F6 ¹ , F7 ¹ , F8 ¹	Miniature Fuse, 5 x 20 mm, Time Delay	AC 250 V / 0.1 A
F9 ¹	Miniature Fuse, 5 x 20 mm, Time Delay	AC 250 V / 1.0 A
F10 ¹	Miniature Fuse, 5 x 20 mm, Time Delay	AC 250 V / 1.2 A



Fuse specifications for AC 120 V systems

DWG Ref.	Description	Rating
F3	Miniature Fuse, 5 x 20 mm, Time Delay	AC 250 V / 1.6 A
F4 ¹	Miniature Fuse, 5 x 20 mm, Time Delay	AC 250 V / 0.5 A
F5 ¹ , F6 ¹ , F7 ¹ , F8 ¹	Miniature Fuse, 5 x 20 mm, Time Delay	AC 250 V / 0.1 A
F9 ¹	Miniature Fuse, 5 x 20 mm, Time Delay	AC 250 V / 1.0 A
F10 ¹	Miniature Fuse, 5 x 20 mm, Time Delay	AC 250 V / 2.0 A

4.14.1 To connect electrical power to the analyzer


1. Open the analyzer enclosure cover to gain access to the field interface terminal block. Refer to *To open an analyzer enclosure cover* → .
2. Install an appropriate compound barrier seal type gland into the M20 access port on the bottom left of the electronics enclosure. Refer to *Application of gland lubricant* → .
3. Run cable from the power distribution panel to the gland.

CAUTION

- ▶ An approved switch or circuit breaker rated for 15 amps should be used and clearly marked as the disconnecting device for the analyzer.
 - ▶ Because the breaker in the power distribution panel or switch is the primary means of disconnecting the power from the analyzer, the power distribution panel or switch should be in close proximity to the equipment and within easy reach of the operator.
4. Pull ground, neutral, and hot wires (#14 AWG minimum) into the analyzer enclosure.
 5. Strip back the jacket and/or insulation of the wires just enough to connect to the power terminal blocks (X1).
 6. Attach the neutral and hot wires to the power terminal blocks by connecting the neutral wire to terminal X1-2, the hot wire to terminal X1-1, as shown in *Connecting the signals and alarms* → .
 7. Connect the ground wire to the ground bus bar marked .

WARNING

- ▶ Failure to properly ground the analyzer may create a high-voltage shock hazard.
8. Verify that each connection is secure.
 9. Close the analyzer enclosure cover.

¹ Housed in fuse terminal blocks. Illuminated LED indicates blown fuse. Refer to *Figure 6. Components in SS2100i-2 electronics enclosure* → .

4.15 Connecting the gas lines

Once you have verified that the analyzer is properly wired, you are ready to connect the sample supply and sample return lines. All work should be performed by technicians qualified in pneumatic tubing.

Seamless, stainless steel tubing (electro-plated), 6 mm (¼ in) O.D. x 0.1 mm (0.035 in) is recommended. The SS2100 for trace analytes utilize SilcoTek SN2000 coated tubing. SN2000-coated tubes may be used for the sample supply. Coated tubing is not needed for instrument air, nitrogen, or sample return. If the analyzer comes with a factory installed sample system, consult the system drawings for tubing sizes and attachment points.

NOTICE

- ▶ For systems with integral sample conditioning systems, refer to *SS2100i-2 Technical Information (TI01670C)*.

4.15.1 To connect the sample supply and return lines

1. Connect the supply and return tubes to the analyzer using the stainless steel compression-type fittings provided.
2. Tighten all new fittings 1¼ turns with a wrench from finger tight. For connections with previously swaged ferrules, thread the nut to the previously pulled up position, then tighten slightly with a wrench. Secure tubing to appropriate structural supports as required.
3. Check all connections for gas leaks. Endress+Hauser recommends using a liquid leak detector.

CAUTION

Damage to cell may result.

- ▶ Do not exceed 10 PSIG (0.7 barg) in the sample cell.

4.16 Changing the 4-20 mA current loop mode

CAUTION

Risk of negating or violating specific hazardous area certifications.

- ▶ Changing the current loop mode may negate specific hazardous area certifications.



By default, the 4-20 mA current loop output is factory set to source current. In some instances, it may be necessary to change the 4-20 mA current loop output in the field from source to sink. This work should be performed by personnel qualified in electronics assembly.

WARNING

Hazardous voltage and risk of electric shock.

- ▶ Turn off and lock out system power before opening the electronics enclosure and servicing.

4.16.1 To change the 4-20 mA board from source to sink

1. Disconnect power to the analyzer.
2. Open the analyzer enclosure cover according to the procedure under *To open an analyzer enclosure cover* →  to gain access to the electronics panel.
3. Locate the 4-20 mA current loop board in the upper middle of the electronics panel, as shown in *Figure 6. Components in SS2100i-2 electronics enclosure* → .
4. Unscrew the screws holding the retaining bracket and remove the retaining bracket.
5. Gently pull the 4-20 mA current loop board up off the backplane into which it is plugged.
6. Move the jumper (JMP1) connecting the center pin to pin A, shown in the figure below, to connect the center pin with pin P.

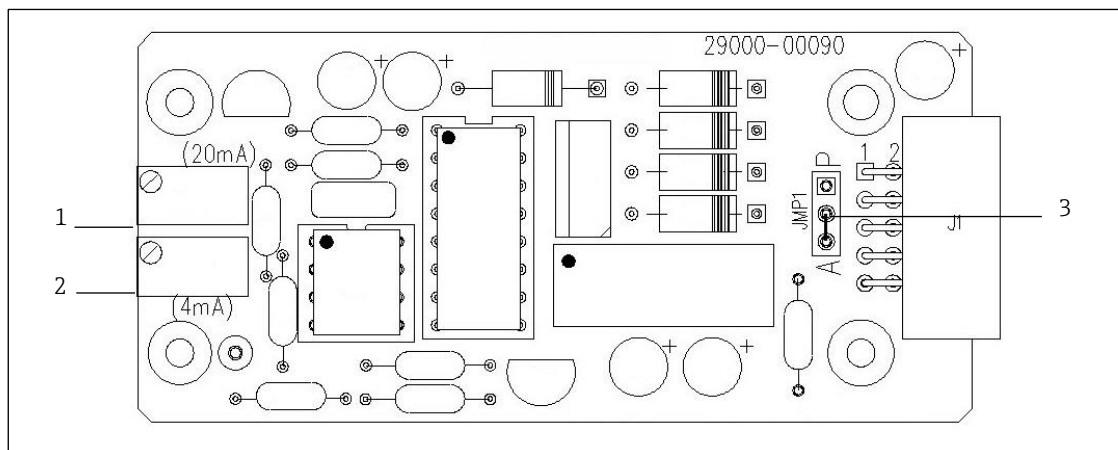


Figure 23. Analyzer 4-20 mA board

1. Zero (4 mA) potentiometer adjustment
 2. Span (20 mA) potentiometer adjustment
 3. Jumper (JMP1)
7. Re-install the 4-20 mA current loop board and retaining bracket.
 8. Reconnect power to the analyzer. Confirm the 4 mA (minimum) and 20 mA (maximum) points. Refer to the appropriate chapter in the *NS5.14 Firmware Description of Device Parameters (GP01180C)*.
 9. Close the analyzer enclosure cover.


5 Specifications

Performance	
Concentration	See analyzer calibration report
Repeatability	See analyzer calibration report
Measurement time ¹	Typically less than 20 seconds
Application data	
Environmental temperature range	Standard: -20 to 50 °C (-4 to 122 °F) Optional: -10 to 60 °C (-14 to 140 °F)
Heated enclosure temperature	50 ±5 °C
Shipment and storage temperatures	Standard: ≥ -20 °C (-4 °F) <i>Analyzers with perm tube validation: > 0 °C (32 °F)</i>
Environmental relative humidity	5% to 95%, Non-condensing
Altitude	Up to 2000 m
Sample cell operating pressure range	800 to 1200 mbar – <i>Standard</i> ; 950 to 1700 mbar – <i>Optional</i>
Pressure to cell	70 kPaG (10 PSIG) maximum to spectrometer cell
Sample flow rate	0.5 to 4 SLPM (0.02 to 0.1 SCFM) ¹
Contaminant sensitivity	None for gas phase glycol, methanol, amines, or mercaptans
Electrical and communications	
Input power, maximum ²	AC 120 or 240 V ±10 %, 50 to 60 Hz standard; ~300 W ¹
Communications	Analog: Isolated Analog channels, 1200 ohms at DC 24 V maximum Outputs: Qty (Two) 4 to 20 mA (measurement value) Input: Qty (One) 4 to 20 mA (pipeline pressure) ¹ Serial: Ethernet and RS-485 half-duplex (Standard)
Digital signals	5 Outputs: Hi/Lo Alarm, General Fault, Validation Fail ¹ , Validation 1 Active ¹ , Validation 2 Active ¹ 2 Inputs: Flow Alarm ¹ , Validation Request ¹
Protocol	Modbus Gould RTU, Daniel RTU or ASCII
Diagnostic value examples	Detector Power (Optics Health), Spectrum Reference Comparison and Peak Tracking (Spectrum Quality), Cell Pressure and Temperature (Overall System Health)
LCD display	Concentration, Cell Pressure, Cell Temperature, and Diagnostics
Physical specifications	
Electronics enclosure	IP66 Copper-free Aluminum with Weather-resistant Polyurethane Powder Coating, 80 to 120 micron thickness
Sample system enclosure(s)	IP55 (min.) 304 or 316L stainless steel
Dimensions ³ (H × W × D)	670 × 1270 × 248 mm (26.3 × 50 × 9.7 in)
Weight ³	Approximately 145 kg (320 lb) (not including sample conditioning system)
Sample cell construction	Standard: 316L-series polished stainless steel

¹ Application dependent.

² Supply voltage not to exceed +10% of nominal. Transient over-voltages according to Over-voltage category II.

³ Dimensions are for analyzer only. Consult system drawings for analyzers with sample conditioning systems.

Area classification	
Analyzer (electronics and laser) ¹	ATEX / IECEx / INMETRO  II 2 G Ex db IIB+H2 T4 Gb -20 °C ≤ Tamb ≤ +60 °C CML 21 ATEX 11305X; IECEx CML 21.0154X; CPEX 23.1043X CE

5.1 Exd accessory conditions of use

All accessories listed in the following table must comply with the latest IEC/EN 60079-0 and IEC/EN 60079-1 standards in addition to the conditions listed on the following page.

Accessory type	Rating	Notes
Stopper plug	Exd, Zone 1	Stopping plugs must be assembled in such a way that their protrusion from an associated enclosure is not increased. Installer must ensure the stopping plug ingress protection matches the ingress protection rating of the associated enclosure, IP66.
Reducer/adaptor	Exd, Zone 1	Adapter/reducers must be assembled in such a way that their protrusion from an associated enclosure is not increased. Installer must ensure the stopping plug ingress matches the ingress protection of the rating of the associated enclosure, IP66. For direct entry Exd applications, only one adapter/reducer should be used per cable entry. The female connection thread of a Thread Conversion Adapter should “step” not more than 2 sizes up in the case of a thread gender change.
Breather/drain	Exd, Zone 1	The breather/drain is suitable for bottom entry application only. It is the user’s responsibility to ensure that the ingress protection level of an associated enclosure is maintained at the interface, IP66. Breather/drain specified must meet the following requirements: Exd enclosures with an internal volume 75 L ≤ V ≤ 175 L Exd enclosure reference pressure 40 bar maximum.
Cable gland(s)	Exd, Zone 1	Compound barrier cable glands must be specified for use with Endress+Hauser analyzer Exd enclosure. Compound barrier cable glands must carry a minimum IP66 ingress protection level.

¹ Including an “X” after the certificate number indicates that the product is subject to the Special Conditions of Use specified in the schedule to this certificate. Refer to the Special Conditions of Use under the relevant certification prior to installation or use.

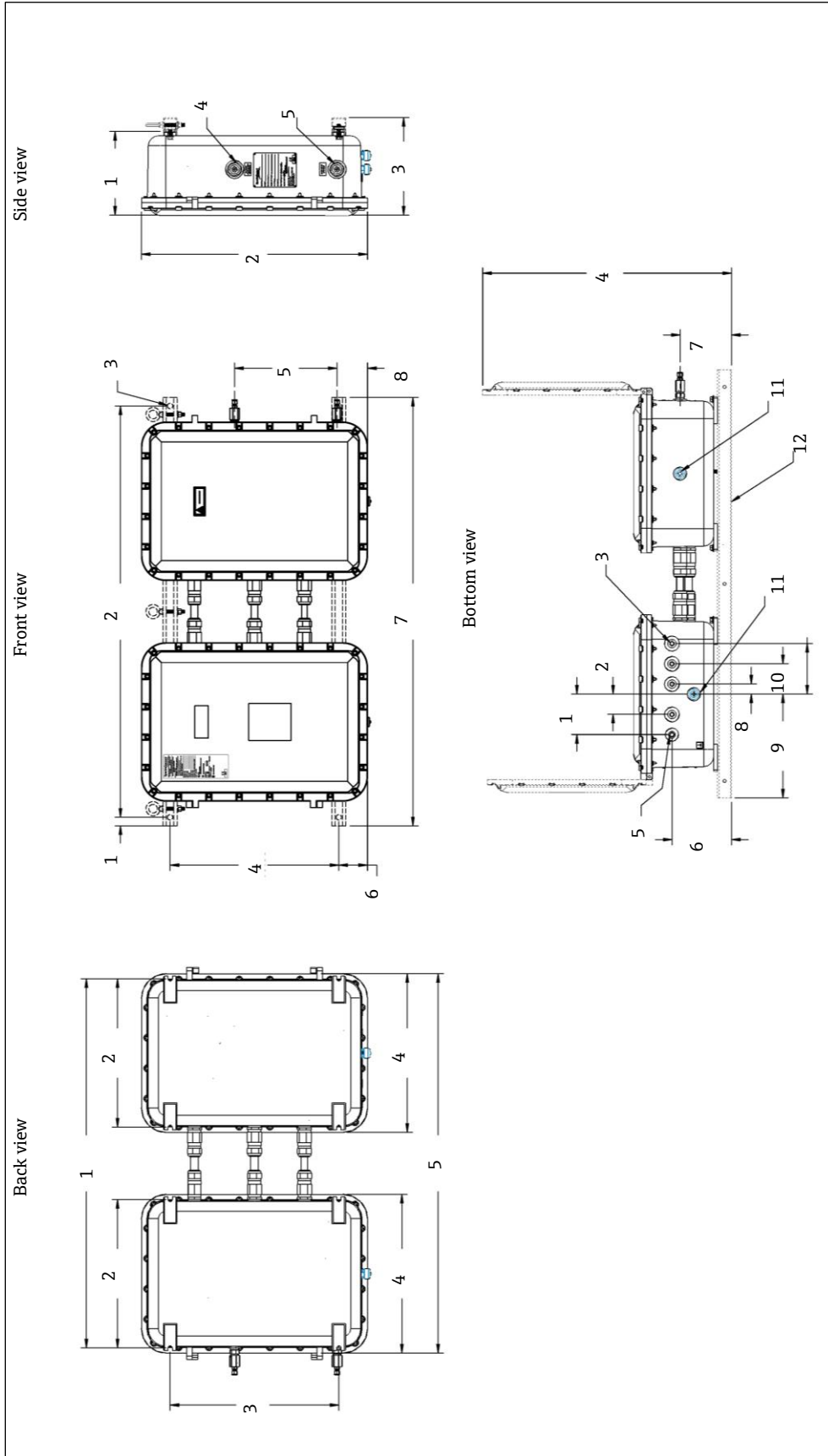


Figure 24. Dimensions and external components of SS2100i-2 (cable-coupled configuration)

- | | | | |
|-----------------------|-----------------------|---------------------------------------|--------------------------|
| Back view | Front view | Side view | Bottom view |
| 1. 1037 mm (40.82 in) | 1. 25 mm (1 in) | 1. 248 mm (9.76 in) | 1. 120 mm (4.72 in) |
| 2. 440 mm (17.32 in) | 2. 1219 mm (48 in) | 2. 670 mm (26.38 in) | 2. 60 mm (2.36 in) |
| 3. 500 mm (19.69 in) | 3. 4x 16 mm (Ø.63 in) | 3. 289 mm (11.39 in) | 3. 4x M25 |
| 4. 470 mm (18.50 in) | 4. 500 mm (19.69 in) | 4. Gas in: 0.25 in O.D. tube fitting | 4. 721 mm (28.4 in) |
| 5. 1067 mm (42.00 in) | 5. 304 mm (11.95 in) | 5. Gas out: 0.25 in O.D. tube fitting | 5. M20 |
| | 6. 85 mm (3.35 in) | | 6. 177 mm (6.95 in) |
| | 7. 1270 mm (50 in) | | 7. 151 mm (5.96 in) |
| | 8. 91 mm (3.56 in) | | 8. 30 mm (1.18 in) |
| | | | 9. 337 mm (13.25 in) |
| | | | 10. 90 mm (3.54 in) |
| | | | 11. Breather |
| | | | 12. Optional strut frame |

6 Maintenance and troubleshooting

WARNING

INVISIBLE LASER RADIATION


- ▶ Avoid exposure to beam. Class 3B radiation product. Refer servicing to the manufacturer-qualified personnel.

CAUTION

Tampering with seal of optical head assembly will result in loss of device sensitivity and inaccurate measurement data.

- ▶ The optical head has a seal and “WARNING” sticker to prevent inadvertent tampering with the device. Do not attempt to compromise the seal of the optical head assembly. Repairs can then only be performed by the factory and are not covered under warranty.

This section presents recommendations and solutions to common problems, such as gas leaks, excessive sampling gas temperatures and pressures, electrical noise, and contamination. For other issues related to the sample conditioning system (SCS), please refer to the SCS operating instruction.

Contact Service if your analyzer is demonstrating other issues. Refer to *Service* → .

6.1 Gas leaks


The most common cause of erroneous measurements is outside air leaking into the sample supply line. It is recommended the supply lines are periodically leak-tested, especially if the analyzer has been relocated or has been replaced or returned to the factory for service and the supply lines have been reconnected.

CAUTION

Do not use plastic tubing of any kind for sample lines. Plastic tubing is permeable to moisture and other substances which can contaminate the sample stream.

- ▶ Seamless, stainless steel tubing (electro-plated), 6 mm (¼ in) O.D. x 0.1 mm (0.035 in) is recommended. The SS2100 for trace analytes utilize SilcoTek SN2000 coated tubing. SN2000-coated tubes may be used for the sample supply. Coated tubing is not needed for instrument air, nitrogen, or sample return.
- ▶ Process samples may contain hazardous material in potentially flammable or toxic concentrations. Personnel should have a thorough knowledge and understanding of the physical properties of the sample and prescribed safety precautions before operating the analyzer.

6.2 Excessive sampling gas temperatures and pressures

The embedded software is designed to produce accurate measurements only within the allowable cell operating range. Refer to *Specifications* →  for more information on operating ranges.

NOTICE


Pressures and temperatures outside of the cell temperature range (± 5 °C) trigger a Pressure Low Alarm, Pressure High Alarm, Temp Low Alarm, or Temp High Alarm fault.

- ▶ The cell temperature operating range for analyzers that are equipped with heated enclosures is equal to the enclosure temperature set point ± 5 °C.

Refer to the *NS5.14 Firmware Description of Device Parameters (GP01180C)* for more information on alarms.

NOTICE

Pressure, temperature and any other readings should always appear accurate.

- ▶ If the pressure, temperature, or any other readings on the LCD appear inaccurate, check them against the *Specifications* → .


6.3 Electrical noise

High levels of electrical noise can interfere with laser operation and cause it to become unstable. Always connect the analyzer to a properly grounded power source.

6.4 Contamination

Contamination and long exposure to high humidity are valid reasons for periodically cleaning the gas sampling lines. Contamination in the gas sampling lines can potentially find its way to the sample cell and deposit on the optics or interfere with the measurement in some other way. Although the analyzer is designed to withstand some contamination, it is recommended to always keep the sampling lines as contamination-free as possible.


6.4.1 To keep the sampling lines clean

1. Make sure that a membrane separator filter (included with most systems) is installed in the sample line leading to the analyzer and is operating normally. Replace the membrane if necessary. If liquid enters the cell and accumulates on the internal optics, a **Laser Power Low Alarm** fault will result.
2. If mirror contamination is suspected, see *Cleaning the mirrors* → .
3. Turn off the sample valve at the tap in accordance with site lockout/tagout rules.
4. Disconnect the gas sampling line from the sample supply port of the analyzer.
5. Wash the sampling line with alcohol or acetone and blow dry with mild pressure from a dry air or nitrogen source.
6. Once the sampling line is completely free of solvent, reconnect the gas sampling line to the sample supply port of the analyzer.
7. Check all connections for gas leaks. Endress+Hauser recommends using a liquid leak detector.

6.4.2 Mirror contamination


If contamination makes its way into the cell and accumulates on the internal optics, a **Laser Power Low Alarm** fault results.

6.5 Cleaning the mirrors

If mirror contamination is suspected in your SS2100i-2, contact Service before attempting to clean the mirrors. Refer to *Service* → . If advised to do so, use the following procedure to clean the mirrors.

 **CAUTION**

Inappropriately cleaning the mirrors can compromise system warranty.

- ▶ This procedure should be used **ONLY** when necessary and is not part of routine maintenance. Refer to *Service* →  before cleaning mirrors to avoid compromising the system warranty.

 **WARNING**

INVISIBLE LASER RADIATION


- ▶ Avoid exposure to beam. Class 3B radiation product. Refer servicing to the manufacturer-qualified personnel.

6.5.1 Tools and supplies

- Lens cleaning cloth (Cole-Parmer® EW-33677-00 TEXWIPE® Alphawipe® Low-Particulate Clean Room Wipes or equivalent)
- Reagent-grade isopropyl alcohol (Cole-Parmer® EW-88361-80 or equivalent)

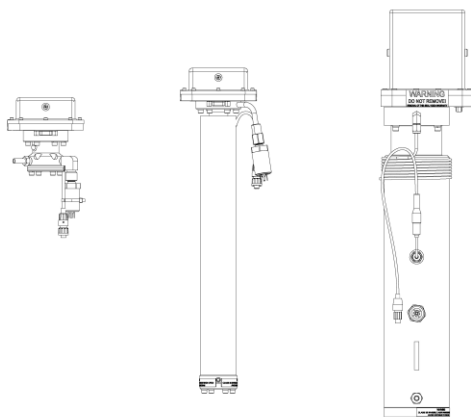
CAUTION

Alcohol can be hazardous.

- ▶ Follow all safety precautions when in use and thoroughly wash hands prior to eating.
- Small drop dispenser bottle (Nalgene® 2414 FEP Drop Dispenser Bottle or equivalent)
- Hemostat (Fisherbrand™ 13-812-24 Rochester-Pean Serrated Forceps or equivalent)
- Bulb blower or dry compressed air/nitrogen
- O-rings (refer to section *Analyzer parts* →  for specific part number)
- Torque wrench
- Permanent ink marker
- Non-outgassing grease
- Flashlight

6.5.2 Determining the type of cell mirror

Measurement cells come equipped with either a glass or stainless steel mirror. Before determining whether to clean or replace the mirror, identify the type of measurement cell being used in the analyzer. There are 4 types of measurement cells: 0.1 m, 0.8 m, 8 m, and 28 m. Refer to the figure below.



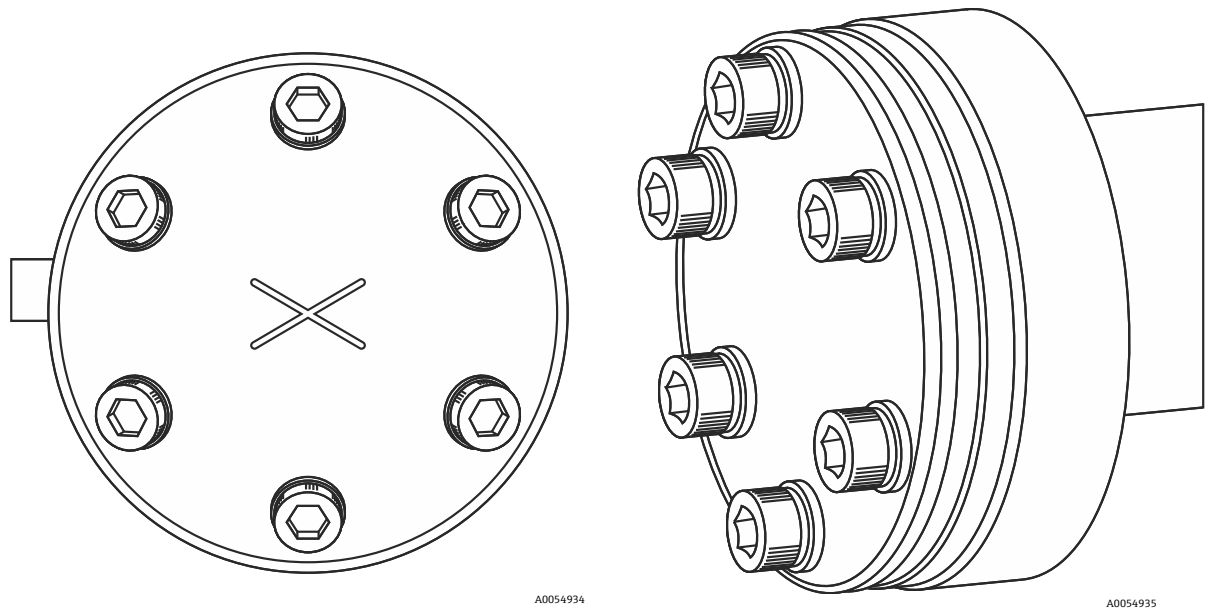
A0054933

Figure 25. Measurement cell types, left to right: 0.1 m cell, 0.8 m cell, 8 m or 28 m cell

Stainless steel mirrors are used with 0.1 m and 0.8 m measurement cells only. They have been identified with either an “X” engraved on the outside bottom of the mirror or a groove around the rim of the mirror. Glass mirrors can be used on any size cell.

To determine the type of mirror being used for the system cell, feel at the bottom of the cell for the engraved “X” marking or the side of the mirror for a groove as in the images below.

- If the bottom surface is smooth, a glass mirror is being used.
- If the bottom surface is rough or engraved, or a groove on the side of the mirror is detected, a stainless steel mirror is being used.



Figures 26 and 27. Stainless steel mirror marking: mirror with engraved X (left), mirror with grooved rim (right)

NOTICE

Only the stainless steel mirror can be replaced. A glass mirror cannot be replaced. A stainless mirror may only be replaced with a stainless steel mirror.

- ▶ Do not attempt to replace a glass mirror with a stainless steel mirror. System calibration may be adversely affected.

To clean the mirror, refer to the following instructions. To replace a stainless steel mirror, refer to *Replacing the stainless steel mirror* →

6.5.3 Cleaning the mirror

NOTICE

Handle cleaning of the mirror with extreme care.

- ▶ Do not clean the top mirror. If the top mirror is visibly contaminated, refer to *Service* → .
- ▶ Careful marking of the mirror orientation is critical to restoring system performance upon reassembly after cleaning.
- ▶ Always handle the optical assembly by the edge of the mount. Never touch coated surfaces of the mirror.
- ▶ Pressurized gas duster products are not recommended for cleaning components. The propellant may deposit liquid droplets onto the optic surface.
- ▶ Never rub an optical surface, especially with dry tissues, as this can mar or scratch the coated surface.

To clean the mirror, follow the instructions for purging the sample conditioning system and removing the mirror assembly, cleaning the mirror, and replacing the mirror, below.

WARNING

INVISIBLE LASER RADIATION – The sample cell assembly contains a low-power, 10 mW maximum, CW Class 3B invisible laser with a wavelength between 750 to 3000 nm.

- ▶ Never open the sample cell flanges or the optical assembly unless the power is turned off.
- ▶ Purge the sample conditioning system and remove the mirror assembly

CAUTION

Take extra caution when handling hazardous materials.

- ▶ All valves, regulators, and switches need to be operated in accordance with site lockout/tagout procedures.

- ▶ Process samples may contain hazardous material in potentially flammable or toxic concentrations. Personnel should have a thorough knowledge and understanding of the physical properties of the sample and prescribed safety precautions before operating the analyzer.

Remove the mirror assembly

1. Power down the analyzer. Refer to the *NS5.14 Firmware Description of Device Parameters (GP01180C)* manual for instructions
2. Disconnect the sample supply and return tubes from the analyzer.
3. If possible, purge the system with nitrogen for 10 minutes.
4. Carefully mark the orientation of the mirror assembly with a permanent ink marker on the cell body.
5. Gently remove the mirror assembly from the cell by removing the socket-head cap screws and set the mirror assembly on a clean, stable and flat surface.


Clean the mirror

1. For the 28 m and 8 m cells, use a flashlight to examine the top mirror inside the sample cell. Ensure that there is no contamination on it. For 0.8 m cells, skip and proceed to the next step.
2. Using a bulb blower or dry compressed air/nitrogen, remove dust and other large particles of debris.
3. Put on clean acetone-impenetrable gloves.
4. Double fold a clean sheet of lens cleaning cloth. Using hemostats or your fingers, clamp near and along the fold to form a “brush.”
5. Place a few drops of isopropyl alcohol onto the mirror and rotate the mirror to spread the liquid evenly across the mirror surface.
6. With gentle, uniform pressure, wipe the mirror from one edge to the other with the cleaning cloth only once and only in one direction to remove the contamination. Discard the cloth.
7. Repeat with a clean sheet of lens cleaning cloth to remove the streak left by the first wipe.
8. Repeat step 7, if necessary, until there is no visible contamination on the mirror.

Replace mirror and components

1. Carefully replace the mirror assembly onto the cell in the same orientation as previously marked.
2. Add a very thin layer of non-outgassing grease to the O-ring.
3. Replace the O-ring and ensure it is properly seated.
4. Tighten the socket-head cap screws evenly with a torque wrench to 30 in-lbs (28 m or 8 m measurement cell) or 13 in-lbs (0.1 m or 0.8 m measurement cell).

6.5.4 Replacing the stainless steel mirror

If your system is configured with a stainless steel mirror in the 0.1 m or 0.8 m measurement cell, use the following instructions for replacing the mirror. If stainless steel mirrors are replacing another type of mirror in the field, such as glass, the analyzer may need to be returned to the factory for recalibration to ensure optimal cell function. Refer to *Service* → .

WARNING

Process samples may contain hazardous material in potentially flammable and toxic concentrations.


- ▶ Personnel should have a thorough knowledge and understanding of the physical properties and safety precautions for the sample contents before operating the SCS.
- ▶ All valves, regulators, switches should be operated in accordance with site lockout/tagout procedures.

The sample cell assembly contains a low-power, 10 mW MAX, CW Class 3B invisible laser with a wavelength between 750 to 3000 nm.

- ▶ Never open the sample cell flanges or the optical assembly unless the power is turned off.

NOTICE

Use caution when replacing the stainless steel mirror.

- ▶ Always handle the optical assembly by the edge of the mount. Never touch the optical surfaces of the mirror.
- ▶ Refer to *Service* →  if a glass mirror requires replacement. Do not attempt to replace a glass mirror with a stainless steel mirror or system calibration may be adversely affected.

To replace a stainless steel mirror, follow the instructions for purging the sample conditioning system and removing the mirror assembly, and replacing the mirror, below.

Purge the sample conditioning system and remove the mirror assembly

1. Power down the analyzer following the procedure outlined in the section called *Powering Down the Analyzer* in the *NS5.14 Firmware Description of Device Parameters (GP01180C)*.
2. Isolate the analyzer from the sample bypass flow by shutting off the appropriate valve(s) and pressure regulator. Disconnect the sample supply and return tubes from the analyzer.
3. Purge the system with nitrogen for 10 minutes.
4. Gently remove the mirror assembly from the cell by removing the socket-head cap screws and set on a clean, stable, and flat surface.
5. Confirm the need to replace mirror due to contamination. If yes, set mirror aside and following remaining steps. If no, restore the mirror to the measurement cell.

Replace the mirror



1. Put on clean acetone-impenetrable gloves.
2. Obtain the new stainless steel mirror.
3. Check the O-ring. If a new O-ring is needed, apply grease on fingertips and then to the new O-ring.
4. Place newly greased O-ring into the groove around the outside of the mirror taking care not to touch the mirror surface.
5. Carefully place the new stainless steel mirror onto the cell making sure the O-ring is properly seated.
6. Tighten the socket-head cap screws evenly with a torque wrench to 13 in-lbs.

6.6 Replacing the pressure sensor

A pressure sensor may need to be replaced in the field due to one or more of the following conditions:

- Loss of pressure reading
- Incorrect pressure reading
- Pressure sensor not responding to pressure change
- Physical damage to the pressure sensor

Refer to the following information to replace the pressure sensor:

- Replacing the pressure sensor on an 8 m or a 28 m cell → 
- Replacing the pressure sensor on a 0.1 or 0.8 m cell → 

Tools and materials

- Acetone-impenetrable gloves (North NOR CE412W Nitrile Chemsoft™ CE Cleanroom Gloves or equivalent)
- $\frac{9}{16}$ " wrench
- $\frac{7}{8}$ " wrench
- $\frac{9}{64}$ " Allen wrench
- Flat-head screwdriver
- Phillips-head screwdriver
- Metal pick
- Military grade stainless steel PTFE tape (or equivalent)
- Dry nitrogen
- Isopropyl alcohol

CAUTION

Isopropyl alcohol can be hazardous.

- ▶ Follow all safety precautions when in use and thoroughly wash hands prior to eating.

6.6.1 Replacing the pressure sensor on an 8 m or a 28 m cell

This procedure is broken into four parts:

- Purge the system and powering down
- Disconnect relevant components
- Replace the pressure sensor
- Reconnect components and performing a leak test

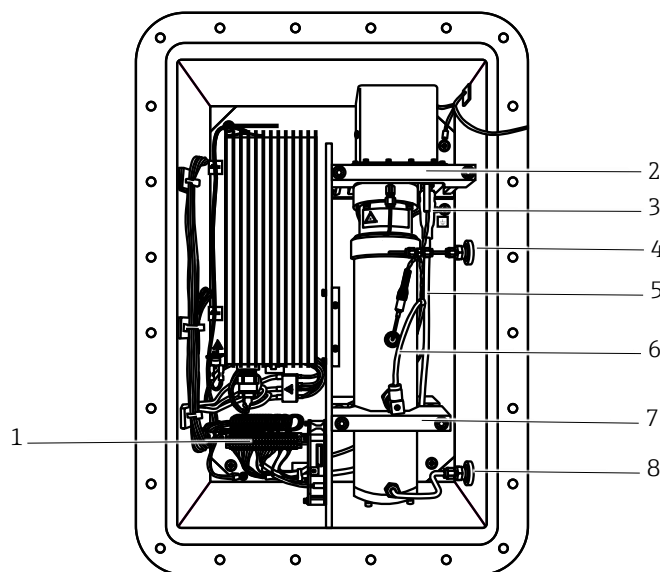
Purge the system and power down

1. Close the external flow of gas at the sample inlet.
2. Purge the system by connecting dry nitrogen to the sample inlet. Allow the SCS to purge for 5 to 10 minutes.
3. Close the nitrogen flow.
4. Power off the system. Refer to the *NS5.14 Firmware Description of Device Parameters (GP01180C)* for this analyzer and the instructions *Powering down the analyzer*.
5. Open the door to the SCS enclosure. Refer to the SCS interior images below.

Disconnect components

1. Remove the optical cable harness using a flat-head screwdriver.
2. Disconnect the measurement cell inlet using a $\frac{9}{16}$ " wrench.
3. Disconnect the measurement cell outlet using a $\frac{9}{16}$ " wrench.
4. Disconnect the thermistor cable at the circular connector.
5. Remove the pressure sensor cable from the circular connector inside the enclosure.

For newer model pressure transducers with quick-disconnects, detach the pressure sensor cable from the pressure sensor at the connector using a Phillips-head screwdriver. Do not remove the black connector from the cable inside the enclosure.



A0055779

Figure 28. Cell cabinet interior

- | | |
|--------------------------|--------------------------|
| 1. Terminal relays | 5. Thermistor cable |
| 2. Mounting bracket | 6. Pressure sensor cable |
| 3. Optical cable harness | 7. Cell outlet |
| 4. Cell inlet | |

6. Unmount the cell from the bracket by removing the four securing screws (two on top, two on the bottom) using a $\frac{9}{64}$ " Allen wrench.
7. Place the measurement cell on a clean, flat surface with the pressure sensor facing up. Refer to the figure below.

NOTICE

- ▶ Orient the measurement cell to prevent any debris from entering the cell.

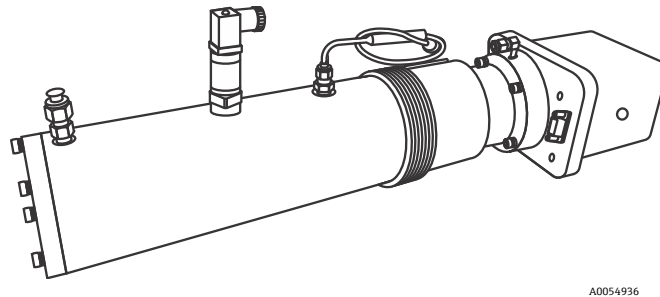


Figure 29. Removed measurement cell with pressure sensor oriented up

8. Holding the cell firmly with one hand, use a $\frac{7}{8}$ in wrench to remove the old (to be replaced) pressure sensor as shown below.

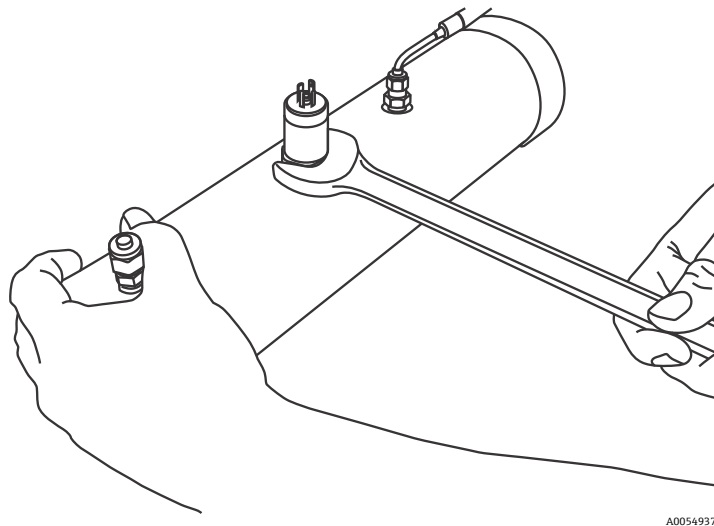



Figure 30. Removing the old pressure sensor

9. Turn the $\frac{7}{8}$ in wrench counterclockwise to loosen the pressure sensor until it can be removed.

Replace the pressure transducer

1. Remove excess seal tape from the threads at the opening and check for galling.

CAUTION

- ▶ Tip the measurement cell forward so that any loose debris falls to the flat surface and not back inside the cell.
- ▶ Threads showing signs of galling indicate a possible leak. Refer to *Service* →  to arrange for repair.

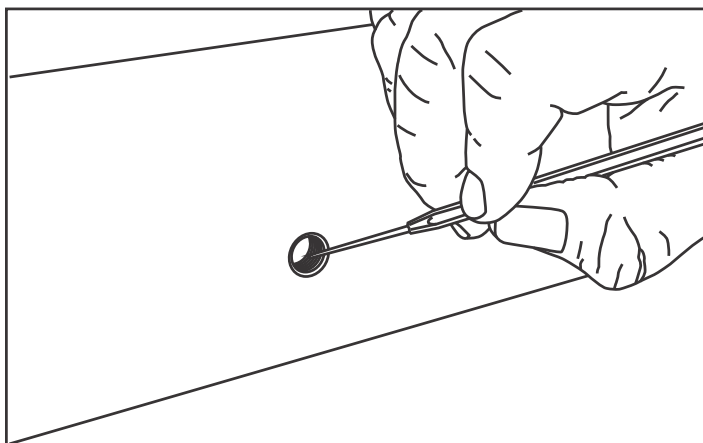



Figure 31. Removing excess seal tape from flange

2. Put on acetone-impenetrable gloves and remove the mirror end cap from the cell using the 9/64 in Allen wrench.
3. Check the mirror for any signs of debris. If found, refer to *Cleaning the mirror* →  to remove.
4. Check for tape fragments inside the cell and remove with a swab as shown below.

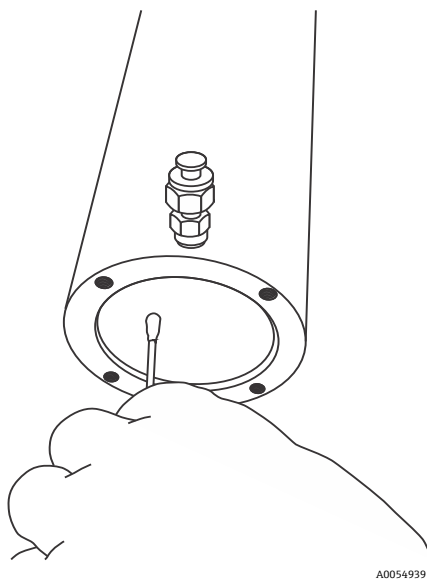


Figure 32. Removing excess seal tape from inside measurement cell

5. Remove the new pressure sensor from the packaging. Retain the black connector cap on the sensor. Do not remove the cap.

6. Wrap stainless steel PTFE tape around the threads at the top of the pressure sensor, beginning from the base of the threads to the top, approximately 3 times taking care to avoid covering the top opening.

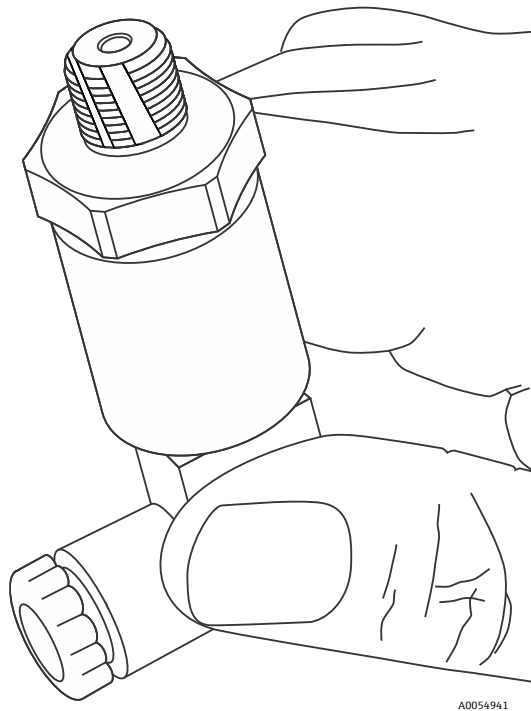


Figure 33. Replacing the seal tape

7. Holding the cell steady, insert the new pressure sensor into the threaded opening.

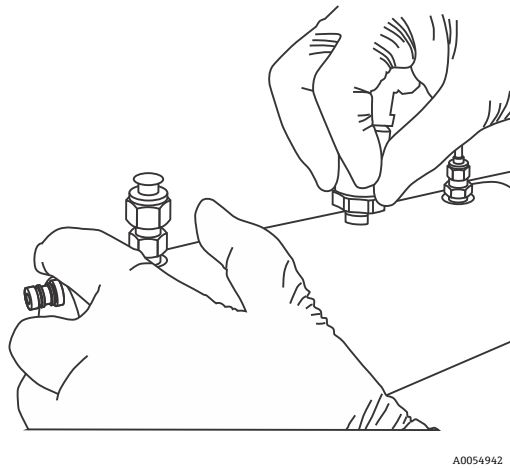


Figure 34. Replacing the pressure sensor

8. Hand-tighten the pressure sensor clockwise into the opening until no longer moving freely.
9. Holding the cell in place, turn the sensor clockwise with a $\frac{7}{8}$ in wrench until tight. Two or three threads on the pressure sensor should still be visible.

NOTICE

- ▶ Make sure the black connector at the end of the pressure sensor is facing towards the head or the base of the measurement cell to facilitate connection. Refer to the figure below.

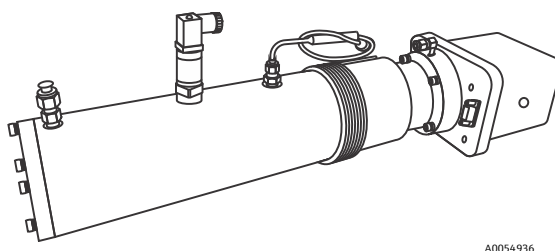


Figure 35. New pressure sensor installed.

Reconnect components and perform leak test

1. Remove the black connector from the pressure sensor and discard.
2. Connect the new harness/cable to the new pressure sensor.

NOTICE

- ▶ If the newer model pressure sensor cable is currently installed in the SCS, a new cable may not be required. If no new cable is installed, re-attach the existing cable.
3. Mount the cell to the mounting brackets using a $\frac{9}{64}$ in Allen wrench with the pressure sensor facing out towards the cabinet door.
 4. Reconnect the cell inlet and cell outlet using a $\frac{9}{16}$ in wrench.
 5. Reconnect the thermistor connector.
 6. Connect the new pressure sensor harness and cable to the circular connector.
 7. Reconnect the optical cable harness.
 8. Close the analyzer enclosure cover.
 9. Conduct a leak test to determine that the new pressure sensor is not leaking.

CAUTION

- ▶ Do not allow cell to exceed 0.7 barg (10 psig) or damage could occur.
- ▶ For any questions related to leak testing the pressure sensor, refer to *Service* → 📄.

Power on the system and run validation

1. Turn the system power on. Refer to the *Standard documentation* for this analyzer for *Powering up the analyzer*.
2. Run a validation on the analyzer. Refer to the *Standard documentation* for instructions on *Validating the Analyzer*.
 - a. If the system passes, the pressure sensor replacement is successful.
 - b. If the system does not pass, refer to *Service* → 📄 for instruction.

6.6.2 Replacing the pressure sensor on a 0.1 or 0.8 m cell

Use the following instruction to replace a pressure sensor on a 0.1 m or 0.8 m measurement cell. This procedure is broken into four parts:

- Purge the system and power down
- Disconnect relevant components
- Replace the pressure transducer
- Reconnect components and perform a leak test

Tools and materials


- $\frac{9}{16}$ " wrench
- $\frac{7}{8}$ " wrench
- $\frac{9}{64}$ " Allen wrench
- Flat-head screwdriver
- Phillips-head screwdriver
- Metal pick
- Military grade stainless steel PTFE tape (or equivalent)
- Dry nitrogen
- Isopropyl alcohol

CAUTION

Isopropyl alcohol can be hazardous.

- ▶ Follow all safety precautions when in use and thoroughly wash hands prior to eating.

Purge the system and power down

1. Close the external flow of gas to the sample conditioning system at the sample inlet.
2. Purge the system by connecting dry nitrogen to the sample inlet. Allow the SCS to purge for 5 to 10 minutes.
3. Close the nitrogen flow.
4. Power off the system. Refer to the *NS5.14 Firmware Description of Device Parameters (GP01180C)* for this analyzer for *Powering down the analyzer*.
5. Open the door to the SCS enclosure. Refer to *Cell cabinet interior* → .

Disconnect components

1. Remove the optical cable harness using a flat-head screwdriver.
2. Disconnect the cell inlet using a $\frac{9}{16}$ in wrench.
3. Disconnect the cell outlet using a $\frac{9}{16}$ in wrench.
4. Disconnect the thermistor cable at the circular connector.
5. Remove the pressure transducer cable from the circular connector inside the enclosure.
6. For newer model pressure transducers with quick-disconnects, detach the pressure transducer cable from the pressure sensor at the connector using a Phillips-head screwdriver. Do not remove the black connector from the cable inside the enclosure.
7. Remove the cell from the bracket by removing the four securing screws (two on top, two on the bottom) using a $\frac{9}{64}$ in Allen wrench. Place the measurement cell on a clean, flat surface with the pressure sensor facing up.

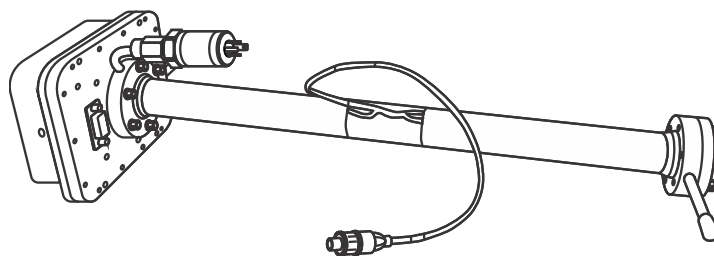
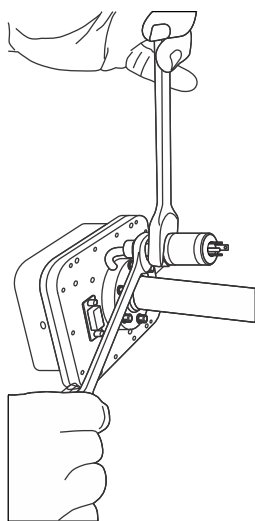


Figure 36. Removed 0.8 m measurement cell with pressure sensor face up.

NOTICE

- ▶ Orient the measurement cell to prevent any debris from entering the cell.

8. Using a $\frac{9}{16}$ in wrench, secure the flange while using a $\frac{7}{8}$ in wrench to remove the old pressure sensor as in the figure.



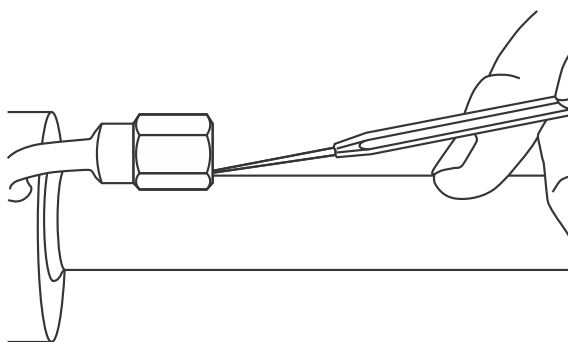
A0054944

Figure 37. Removing the old pressure sensor.

9. Hold the wrench on the flange stable and parallel to the surface. Do not move.
10. Turn the $\frac{7}{8}$ in wrench counterclockwise to loosen the pressure sensor until it can be removed.

Replace the pressure sensor

1. Remove excess seal tape from the flange opening and threads and check threads for galling.




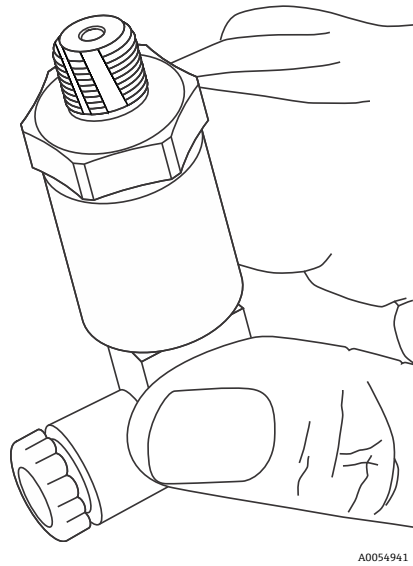
A0054945

Figure 38. Removing excess seal tape from flange.

CAUTION

Threads showing signs of galling indicate a possible leak.

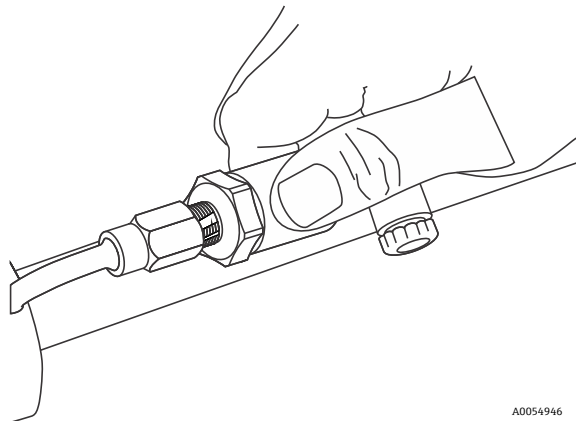
- ▶ Refer to *Service* →  to arrange to return for repair.
2. Remove the new pressure sensor from the packaging. Retain the black connector cap on the sensor. Do not remove the cap.
 3. Wrap stainless steel PTFE tape around the threads at the top of the pressure sensor, beginning from the base of the threads to the top, approximately three times taking care to avoid covering the top opening.



A0054941

Figure 39. Replacing the seal tape.

4. Insert the new pressure sensor into the threaded flange keeping the sensor parallel to the surface for proper fitting.
5. Hand-tighten the pressure sensor turning it counter clockwise into the flange until no longer moving freely.



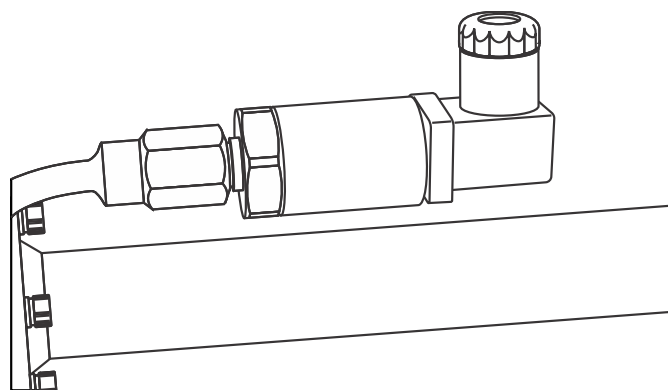
A0054946

Figure 40. Replacing the pressure sensor.

6. Using the $\frac{9}{16}$ in wrench to hold the flange in place, turn the sensor clockwise with a $\frac{7}{8}$ in wrench until tight. Two or three threads on the pressure sensor should still be visible.

NOTICE**Check the orientation of the pressure sensor.**

- ▶ Make sure the black connector at the bottom of the pressure sensor is facing up from the measurement cell.



A0054947

Figure 4.1. Newly installed pressure sensor positioning.

7. Remove the black connector from the pressure sensor and discard.
8. Connect the new harness or cable to the new pressure sensor.


If the new model pressure sensor cable is currently installed in the SCS, reattach the cable to the pressure sensor after the cell has been remounted.

Reconnect components and perform leak test




1. Mount the cell to the mounting brackets using a $\frac{9}{64}$ in Allen wrench with the pressure sensor facing forward.
2. Reinstall cell inlet and cell outlet using a $\frac{9}{16}$ in wrench.
3. Reconnect the thermistor.
4. Reconnect the new pressure sensor harness to the existing cable at the black connector or connect the new pressure sensor harness and cable to the circular connector, as applicable.
5. Reconnect the optical cable harness.
6. Close the analyzer enclosure cover.
7. Connect the sample inlet.
8. Conduct a leak test to determine that the new pressure sensor is not leaking.

CAUTION

Potential damage if cell leak is present.

- ▶ Do not allow cell to exceed 0.7 barg (10 psig) or damage could occur.
- ▶ For any questions related to leak testing the pressure sensor, refer to *Service* → .

Power on the system and run validation

1. Turn the system power on. Refer to *Standard documentation* →  for this analyzer for *Powering up the analyzer*.
2. Run a validation on the analyzer. Refer to *Standard documentation* →  for instructions on *Validating the Analyzer*.
 - a. If the system passes, the pressure sensor replacement is successful.
 - b. If the system does not pass, refer to *Service* →  for instruction.

6.6.3 Replacing the dryer

For product and spare parts ordering information, visit www.endress.com or contact your local sales center.

To replace the dryer

1. Shut off the gas flow (purge the analyzer, depending on gas stream being used).
2. Open the SCS enclosure door.
3. Using a wrench, loosen the fitting at the top and bottom of the dryer.

NOTICE**Only for use on low moisture systems.**

- ▶ The VCR metal gasket face seal fitting is currently used on low moisture systems only.

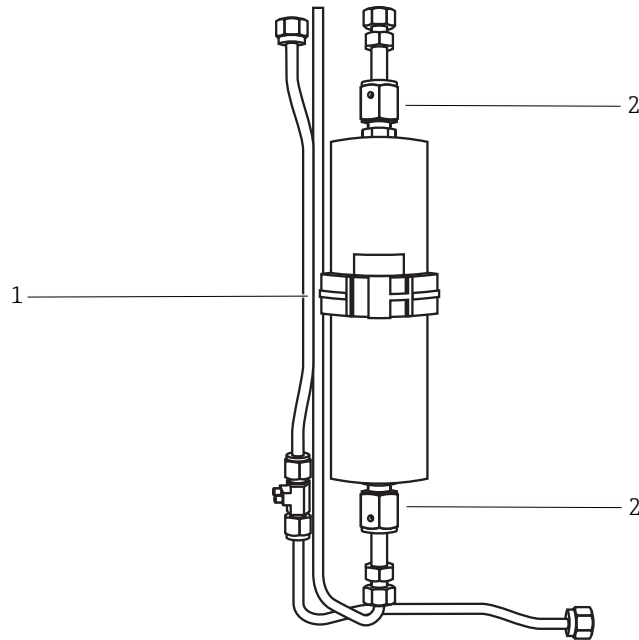


Figure 42. Installed dryer


A0055778

1. Retainer clip
2. Nuts

4. Open the retainer clip by grasping each side and squeezing towards the middle. Carefully release the retainer clip by inserting a screwdriver or similar tool while squeezing.
5. Remove the dryer.
6. Secure the retainer clip gasket to the new dryer unit.
7. Insert the new dryer into the analyzer.
8. Connect the nuts at the top and bottom of the dryer to finger tight.
9. Using a wrench, tighten the nuts $\frac{1}{8}$ turn from finger tight.
10. Close the SCS enclosure door.
11. Turn on gas flow to the analyzer.
12. Perform a leak test.

NOTICE

Contact Service for any questions related to leak testing.

- ▶ Refer to Service → .

6.7 Flame arrestor replacement and safety

The analyzer system comes equipped with a protective covering over the flame arrestors and tubing that runs from the analyzer electronics to the SCS. Refer to the analyzer system drawings to locate the protective enclosure for your analyzer. The location of the protective enclosure can vary by customer configuration.

6.7.1 Tools required



- $\frac{7}{16}$ " angle double open-end wrench
- $\frac{9}{16}$ " angle double open-end wrench
- $\frac{7}{8}$ " wrench

6.7.2 To replace the flame arrestors

1. Ensure all safety requirements have been met and any necessary protective gear and tools are being used.

CAUTION

Removing insulation is potentially harmful. Use caution.

- ▶ Refer to Potential health effects →  before removing insulation.
2. Purge the system following the instructions provided in steps 1 through 8 in *Preparing the analyzer for shipment or storage* → .
 3. Remove the screws holding the protective cover in place and lift the cover to remove from the enclosure.
 4. Remove the insulation packed inside the enclosure and place in a clean, dry area.
 5. Disassemble the tubing using a $\frac{9}{16}$ in wrench.

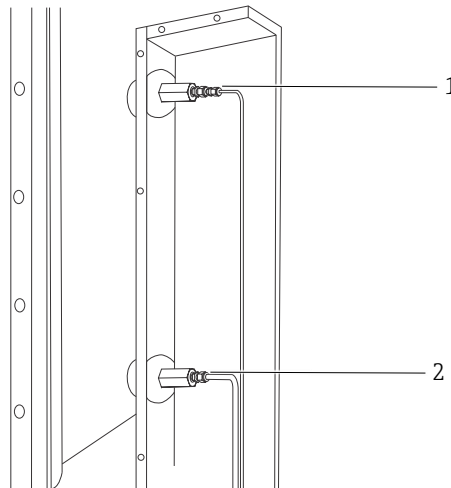


Figure 43. Flame arrestor positions inside the enclosure
A0055822

1. Top flame arrestor
2. Bottom flame arrestor

6. Remove the flame arrestor using a $\frac{7}{8}$ in wrench.
After the seal is broken, the flame arrestor may be loosened by hand and removed.

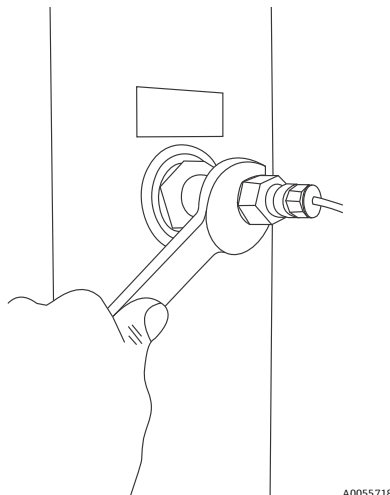


Figure 44. Removing the flame arrestor
A0055718

7. Insert the new flame arrestor ensuring its proper seating inside the washer.
8. Tighten the flame arrestor by hand turning clockwise. Use the hook spanner wrench to fully tighten.
9. Reassemble SCS tubing and conduct a leak test.
10. Repack the insulation into the enclosure and replace the cover.
11. Replace screws to secure the enclosure cover.

6.7.3 Potential health effects

The flame arrestor enclosure is packed with insulation material that can cause health issues if inhaled, exposed to bare skin or in direct contact with eyes. Please follow the safety procedures for unpacking this enclosure to access the flame arrestors and review the following potential health effects of the insulation material before beginning maintenance on the flame arrestors.

- **Eyes:** Direct contact with eye can cause mechanical irritation.
- **Skin:** The material (when in wet state or as a dust) is not chemically harmful if it comes in contact with the skin and is not immediately washed off. However, direct contact of dust and mineral wool fibers with skin can cause skin irritation (mechanical) and itchiness.
- **Ingestion:** No known effects.
- **Inhalation:** Inhalation of dust can cause nose, throat, lungs, and upper respiratory tract irritation. Persons exposed to dust may be forced to leave area because of nuisance conditions such as coughing, sneezing and nasal irritation.
- **Chronic:** Persons with chronic or systemic skin or eye disease should use precautions and wear all personal protective equipment when working with this product.

6.7.4 Transport information

U.S. Department of Transportation (DOT) information: Not a hazardous material per DOT shipping requirements. Not classified or regulated.

6.7.5 Regulatory information

Canadian Regulations

WHMIS: D2B

All components of this product are included in the Canadian Domestic Substances List (DSL) or the Canadian Non-Domestic Substances List (NDSL).

USA Regulations

All ingredients of this product are included in the U.S. Environmental Protection Agency's Toxic Substances Control Act Chemical Substance Inventory. The carcinogenicity classification of the ingredients is listed below.

Material	IARC	NTP
Man-made vitreous fibers	Group 3	None

In October 2001, the International Agency for Research on Cancer (IARC) classified mineral wool fibers (rock or slag) as Group 3 (not classifiable as to carcinogenicity to humans). IARC noted specifically: "no evidence of increased risks of lung cancer or mesothelioma (cancer of the lining of the body cavities) from occupational exposures during manufacture of these materials, and inadequate evidence overall of any cancer risk." this was a reversal of the IARC finding in 1987 of a Group 2B designation (possibly carcinogenic to humans) based on earlier studies in which animals were injected with large quantities of slag wool fibers.

6.7.6 Information for Handling and Identification of Chemical Hazards

Condition	NFPA Ratings	HMIS Ratings	Personal Protection
Health	0	0	Use eye and skin protection. Use NIOSH/MSHA-approved respiratory protection when necessary.
Fire	0	0	
Reactivity	0	0	
Other	N/A		

Legend:

0 = Minimal hazard


1 = Slight hazard

2 = Moderate hazard


3 = Serious hazard










4 = Severe hazard








6.8 Peak tracking reset procedure



The analyzer's software is equipped with a peak tracking function that keeps the laser scan centered on the absorption peak. Under some circumstances, the peak tracking function can get lost and lock onto the wrong peak. If the **PeakTk Restart Alarm** is displayed, reset the peak tracking function. Refer to the *NS 5.14 Description of Device Parameters (GP01180C)* →  for this analyzer for instruction.

6.9 Instrument issues

If the instrument does not appear to be hampered by gas leaks, contamination, excessive sampling gas temperatures and pressures, or electrical noise, refer to the following table before contacting *Service* → .

Symptom	Response
Non-operation (at or after start up)	Is the power connected to both the analyzer and power source? Is the switch on?
	Is the power source good? (AC 100 to 250 V at 50/60 Hz, DC 9 to 16 V, DC 18 to 32 V).
	Check fuse(s). If bad, replace with equivalent fuse.
	Contact Service for more information.
Laser power low alarm	Turn off the power to the unit and check the optical head cables for a loose connection. Do not disconnect or reconnect any optical head cables with the power connected.
	Check the inlet and outlet tubes to see if they are under any stress. Remove the connections to the inlet and outlet tubes and see if the power goes up. The existing tubing may need to be replaced with stainless steel flexible tubing.
	Refer to the <i>NS 5.14 Description of Device Parameters (GP01180C)</i> →  for your analyzer for instructions to capture diagnostic data and submit to Endress+Hauser.
	Possible alignment problem. Contact Service for more information.
	Possible mirror contamination issue. Contact Service for more information, refer to <i>Service</i> . If advised to do so, clean the mirrors by following the instructions <i>Cleaning the mirrors</i> →  .
Power fail	Refer to the <i>Standard documentation</i> →  for this analyzer for instruction.
	Refer to the <i>NS 5.14 Description of Device Parameters (GP01180C)</i> →  for this analyzer for instructions to capture diagnostic data and submit to Endress+Hauser. Contact your service representative.
Null fail	Refer to the Description of Device Parameters for your analyzer for instruction.
	Refer to the <i>NS 5.14 Description of Device Parameters (GP01180C)</i> →  for this analyzer for instructions to capture diagnostic data and submit to Endress+Hauser. Contact your service representative.
Spectrum fail	Reset the Peak Tracking function. Refer to the <i>NS 5.14 Description of Device Parameters (GP01180C)</i> →  for this analyzer for instruction.
	Refer to the Description of Device Parameters for your analyzer for instructions to capture diagnostic data and submit to Endress+Hauser. Contact your service representative.
Track fail	Refer to the Description of Device Parameters for your analyzer for instruction.
	Reset the Peak Tracking function. Refer to the <i>NS 5.14 Description of Device Parameters (GP01180C)</i> →  for this analyzer for instruction.
Pressure low alarm or pressure high alarm	Check that the actual pressure in the sample cell is within specification →  .
	If the pressure reading is incorrect, check that the pressure/temperature cable on the bottom of the electronics enclosure is tight. Check the connector on the pressure sensor. Check the pressure connector on the backplane board.
Temp low alarm or temp high alarm	Check that the actual temperature in the sample cell is within <i>Specifications</i> →  . For systems with a heated enclosure, check that the temperature in the sample cell is within ± 5 °C of the specified enclosure temperature.

Symptom	Response
Temp low alarm or temp high alarm (continued)	If the temperature reading is incorrect, check that the pressure/temperature cable on the bottom of the electronics enclosure is tight. Check the connector on the cell temperature sensor. Check the temperature connector on the backplane board. (Note: A temperature reading greater than 150 °C indicates a short circuit on the temperature sensor leads; a reading of less than -40 °C indicates an open circuit).
System stuck in Fit Delta Exceeds Limit restart for greater than 30 minutes	Contact Service for information.
Not getting enough flow to the sample cell	Check both the micro filter and membrane separator for contamination. Replace if necessary. Refer to the Sample Conditioning System (SCS) section of <i>SS2100i-2 Technical Information (T101670C)</i> for instruction.
	Check if supply pressure is sufficient.
No reading on device connected to current loop	Make sure that connected device can accept a 4-20 mA signal. The analyzer is set to source current.
	Make sure the device is connected to the correct terminals (see <i>Figure 17</i>).
	Check the open circuit voltage (DC 35 to 40 V) across the current loops terminals (see <i>Figure 17</i> → ).
	Replace the current loop device with a milliamperemeter and look for current between 4 mA and 20 mA. A voltmeter connected across a 249 ohm resistor can be used instead of the milliamperemeter; it should read between 1 and 5 V.
Current loop is stuck at 4 mA or 20 mA	Check display for error message. If alarm has been triggered, reset the alarm.
	On the current loop board, check the voltage between the end of resistor R1 closest to the jumper and ground. If the concentration reading is high, the voltage should be near DC 1 V. If the concentration reading is low, the voltage should be near DC 4.7 V. If not, the problem is probably on the ARM9 main board. Return to factory for Service →  .
Front panel display is not lit, and no characters appear	Check for correct voltage on terminal block input. Observe polarity on DC powered units.
	Check for correct voltage after fuses.
	Check for DC 5 V on red wires, DC 12 V on yellow wires, and DC 24 V on orange wires from power supply.
	Check connections on display communication and power cables.
Strange characters appear on front panel display	Check connections on display communication cable.
Pressing keys on front panel do not have specified effect	Check connections on keypad cable.
Reading seems to always be high by a fixed amount	Capture diagnostic data and send the file to Endress+Hauser (refer to the section called “To read diagnostic data with HyperTerminal” in the <i>Standard documentation</i> →  for this analyzer.
Reading seems to always be high by a fixed percentage	Capture diagnostic data and send the file to Endress+Hauser (refer to the section called “To read diagnostic data with HyperTerminal” in the <i>Standard documentation</i> →  for this analyzer.
Reading is erratic or seems incorrect	Check for contamination in the sample system, especially if the readings are much higher than expected.
	Capture diagnostic data and send the file to Endress+Hauser (refer to the section called “To read diagnostic data with HyperTerminal” in the <i>Standard documentation</i> →  for this analyzer.
Reading displays 0.0 or seems relatively low	Capture diagnostic data and send the file to Endress+Hauser (refer to the section called “To read diagnostic data with HyperTerminal” in the <i>Standard documentation</i> →  for this analyzer.
	Check that Peak Tracking is enabled (refer to the section called “To change parameters in Mode 2” in the <i>Standard documentation</i> →  for this analyzer.

Symptom	Response
Reading goes to '0'	If 4 to 20 mA Alarm Action is set to 1, look on display for an error message (refer to the section called "To change parameters in Mode 2" in the <i>Standard documentation</i> →  for this analyzer.
	Gas concentration is equal to zero.
Reading goes to full scale	If 4 to 20 mA Alarm Action is set to 2, look on display for an error message (refer to the section called "To change parameters in Mode 2" in the <i>Standard documentation</i> →  for this analyzer.
	Gas concentration is greater than or equal to full scale value.
Serial output is displaying garbled or no data	Make sure the computer COM port is set for 9600 baud, 8 data bits, 1 stop bit, no parity, and no flow control.
	Be sure no other programs are using the COM port selected.
	Make sure the connections are good. Verify the correct pin connections with an ohm meter.
	Make sure to select the correct COM port into which the cable is plugged.
LCD does not update. Unit is locked up for more than 5 minutes.	Switch off power, wait 30 seconds, and then switch power back on.

6.10 Service

For Service, refer to our website for the list of local sales channels in your area (www.endress.com).

6.11 Service repair order

If returning the unit is required, obtain a **Service Repair Order (SRO) Number** from Service before returning the analyzer to the factory. Your service representative can determine whether the analyzer can be serviced on site or should be returned to the factory. All returns should be shipped to:

Endress+Hauser
 11027 Arrow Route
 Rancho Cucamonga, CA 91730
 United States
www.endress.com

6.12 Packing, shipping, and storage

Endress+Hauser analyzer systems and auxiliary equipment are shipped from the factory in appropriate packaging. The SS2100i-2 analyzer is typically packed in a wooden crate. All inlets and vents are capped and protected when packaged for shipment.

If the equipment is to be shipped immediately or stored for any length of time, it should be packed in the original packaging when shipped from the factory. If analyzer has been installed and or operated (even for purposes of a demonstration), the system should first be decontaminated (purged with an inert gas) before powering down the analyzer.

CAUTION

- ▶ Process samples may contain hazardous material in potentially flammable or toxic concentrations. Personnel should have a thorough knowledge and understanding of the physical properties of the sample and prescribed safety precautions before installing, operating, or maintaining the analyzer.

6.12.1 Preparing the analyzer for shipment or storage

1. Shut off the process gas flow.
2. Allow all residual gas to dissipate from the lines.
3. Connect a purge supply, regulated to the specified sample supply pressure, to the sample supply port.
4. Confirm that any valves controlling the sample flow effluent to the low-pressure flare or atmospheric vent are open.

5. Turn on the purge supply and purge the system to clear any residual process gases.
6. Turn off the purge supply.
7. Allow all residual gas to dissipate from the lines.
8. Close any valves controlling the sample flow effluent to the low-pressure flare or atmospheric vent.
9. Disconnect power to the system.
10. Disconnect all tubing and signal connections.
11. Cap all inlets and outlets to prevent foreign material such as dust or water from entering the system.
12. Pack the equipment in the original packaging in which it was shipped, if available. If the original packaging material is no longer available, the equipment should be adequately secured to prevent excessive shock or vibration.
13. If returning the analyzer to the factory, complete the Decontamination Form provided by Service and attach to the outside of the shipping package as instructed before shipping.

6.13 Storage

The packaged analyzer should be stored in a sheltered environment that is temperature controlled between $-20\text{ }^{\circ}\text{C}$ ($-4\text{ }^{\circ}\text{F}$) and $50\text{ }^{\circ}\text{C}$ ($122\text{ }^{\circ}\text{F}$), and should not be exposed to rain, snow, caustic, or corrosive environments. Humidity in the sheltered environment should be non-condensing.

6.14 Disclaimers

Endress+Hauser accepts no responsibility for consequential damages arising from the use of this equipment. Liability is limited to replacement or repair of defective components.

This manual contains information protected by copyright. No part of this guide may be photocopied or reproduced in any form without prior written consent from Endress+Hauser.

6.15 Warranty

For a period of 18 months from date of shipment or 12 months in operation, whichever comes first, Endress+Hauser warrants that all products sold by it must be free from defects in material and workmanship under normal use and service when correctly installed and maintained. Endress+Hauser's sole liability and Customer's sole and exclusive remedy for a breach of warranty is limited to Endress+Hauser's repair or replacement (at Endress+Hauser's sole option) of the product or part thereof which is returned at Customer's expense to Endress+Hauser's manufacturing facility. This warranty will apply only if Customer notifies Endress+Hauser in writing of the defective product promptly after the discovery of the defect and within the warranty period. Products may only be returned by Customer when accompanied by a return authorization reference number (SRO) issued by Endress+Hauser. Freight expenses for products returned by Customer is prepaid by Customer. Endress+Hauser will pay for shipment back to Customer for products repaired under warranty. For products returned for repair that are not covered under warranty, Endress+Hauser's standard repair charges is applicable in addition to all shipping expenses.

7 Analyzer parts

This chapter provides lists and illustrations of all field replaceable parts used in the SS2100i-2 analyzer. Due to a policy of continuous improvement, parts and part numbers may change without notice.

Not all parts listed are included on every analyzer. When ordering, please specify the system serial number (S/N) to ensure that the correct parts are identified.

Electronics panel assembly parts

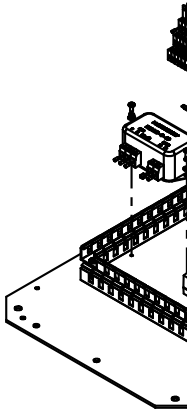
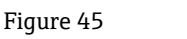
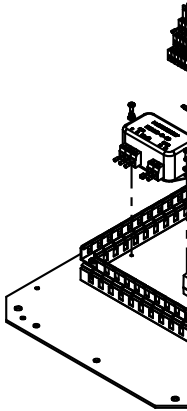
Figure number	Reference number	Material number	Description
 <p>Figure 46</p>	1	70156875	One Phase Filter Model FN2415
 <p>Figure 45</p>	2	70157024	Power Supply, AC 100 to 240 V, DC 24 V / 1.3 A
 <p>Figure 46</p>	3	70156988	Relay, With Socket, C1D2, 6 A, DC 12 V, SPDT

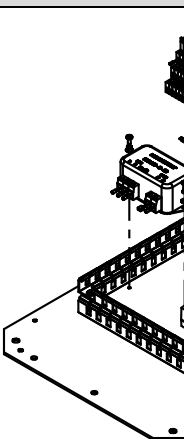
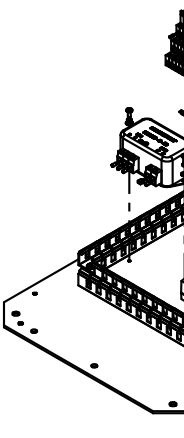
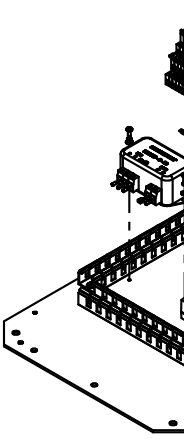
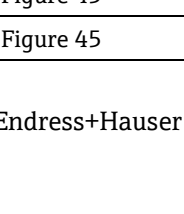
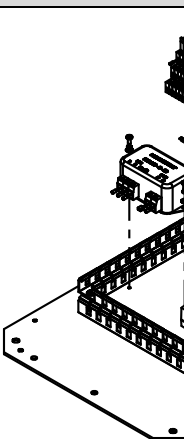
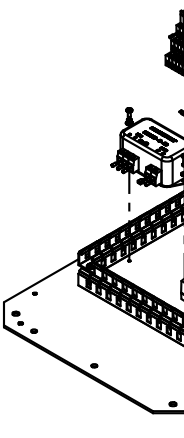
Figure number	Reference number	Material number	Description
 <p>Figure 46</p>	4	70156896	Thermostat, Manual Reset, 2455RM
 <p>Figure 46</p>	5	70156904	Assembly, Power Supply, Traco
 <p>Figure 45</p>	6	70162329	Assembly, PCB, Daughter, H2S, ARM9
 <p>Figure 46</p>	7	70162331	Assembly, PCB, 4 to 20 mA, Dual Adjustable, Low Noise
 <p>Figure 45</p>	8	70156894	Temperature Controller, Watlow, EZ-ZONE RM
 <p>Figure 45</p>	9	70156877	Relay, 861 Solid State with Internal Heat Sink

Figure number	Reference number	Material number	Description
Figure 47	10	70162330	Assembly, Analog Input Board
Figure 45	11	70162332	PCB, Assembly Temperature Control Hytek, 28 meter

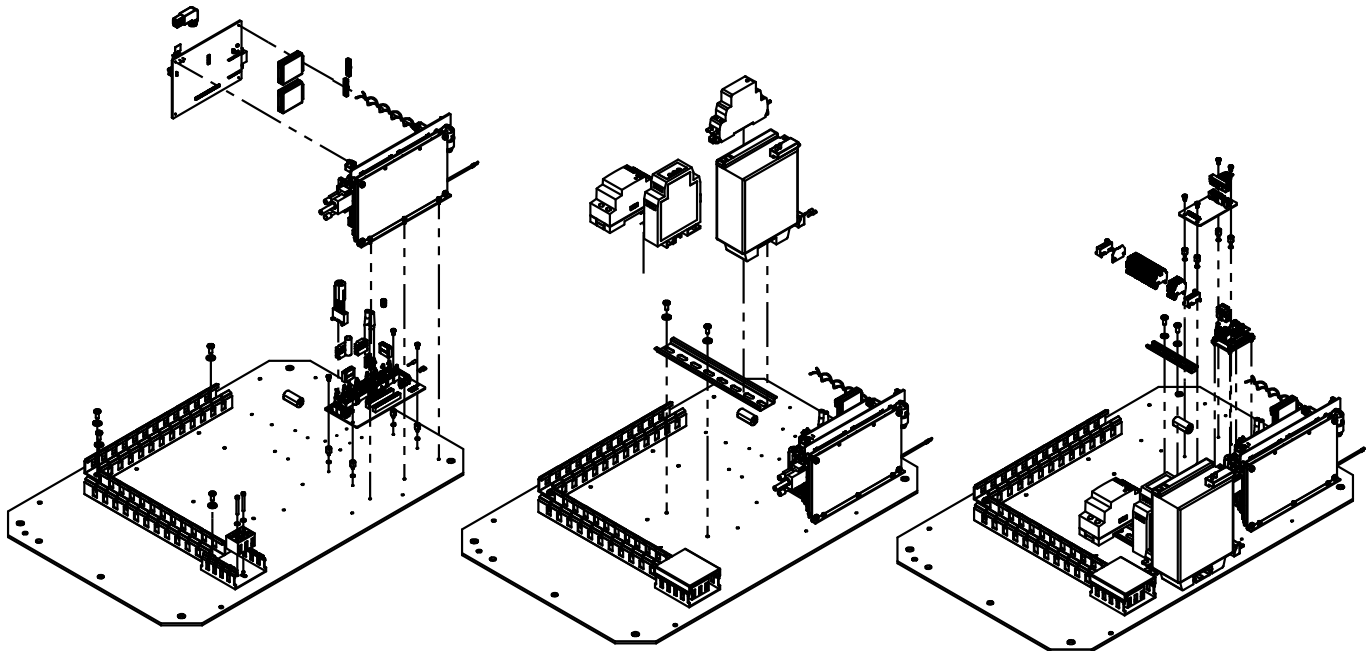


Figure 45. Electronics panel assembly parts

A0055719

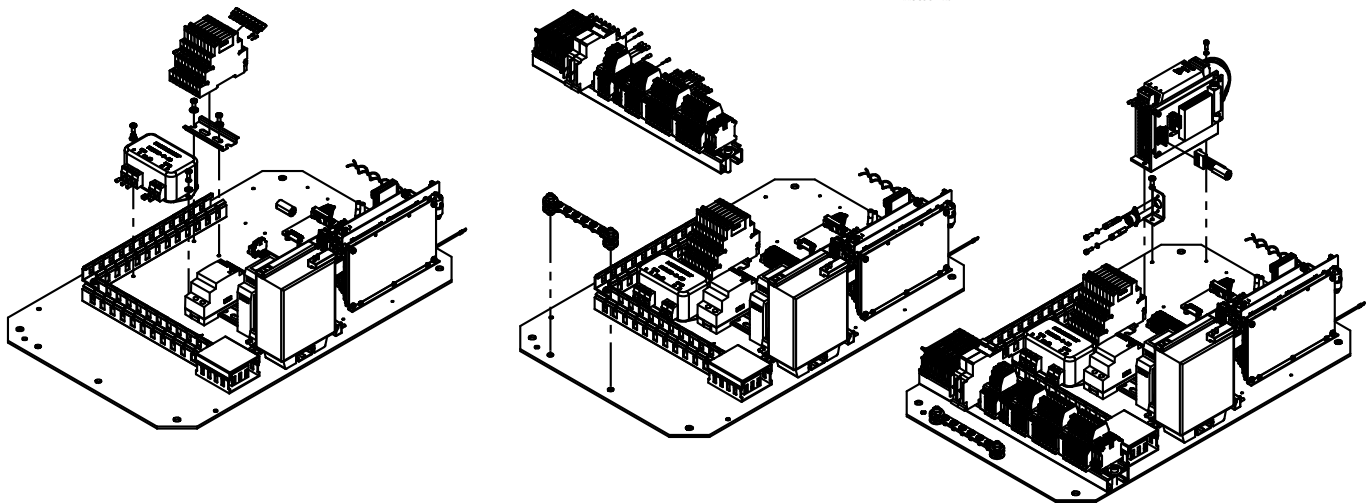
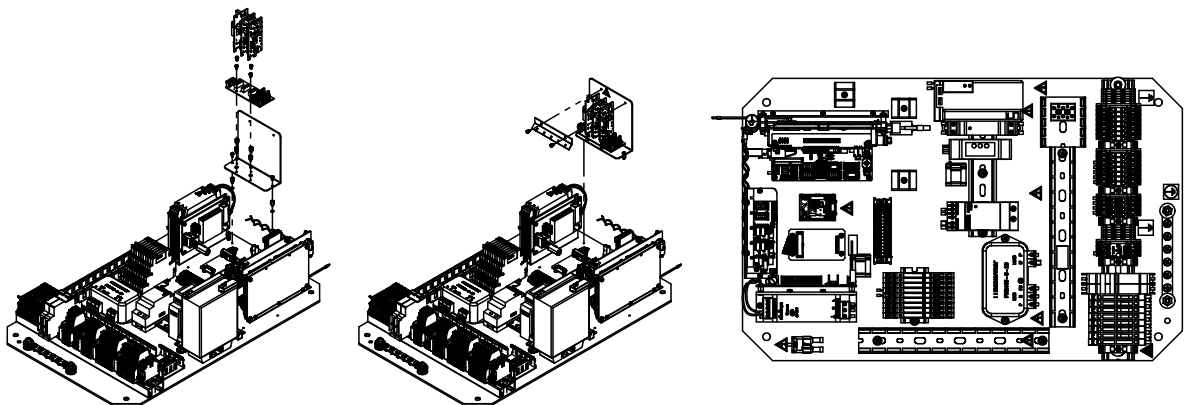


Figure 46. Electronics panel assembly parts (continued)

A0055720



A0055721

Figure 47. Electronics panel assembly parts (continued)

Figure number	Reference number	Material number	Description
Figure 48	1	70159149	Circuit Breaker, 9926 Series
Figure 48	2	70156874	Terminal Block Fuse, UK 5-HESILA 250, Un-500V, In-6.3A
Figure 48	3	70156930	Fuse, Miniature, 5 x 20 mm, 0.5 A
Figure 48	4	70156929	Fuse, Miniature, 5 x 20 mm, 0.1 A
Figure 48	5	70162333	Fuse, Miniature, 5 x 20 mm, 1 A
Figure 48	6	70159147	Fuse, Miniature, 5 x 20 mm, 1.2 A

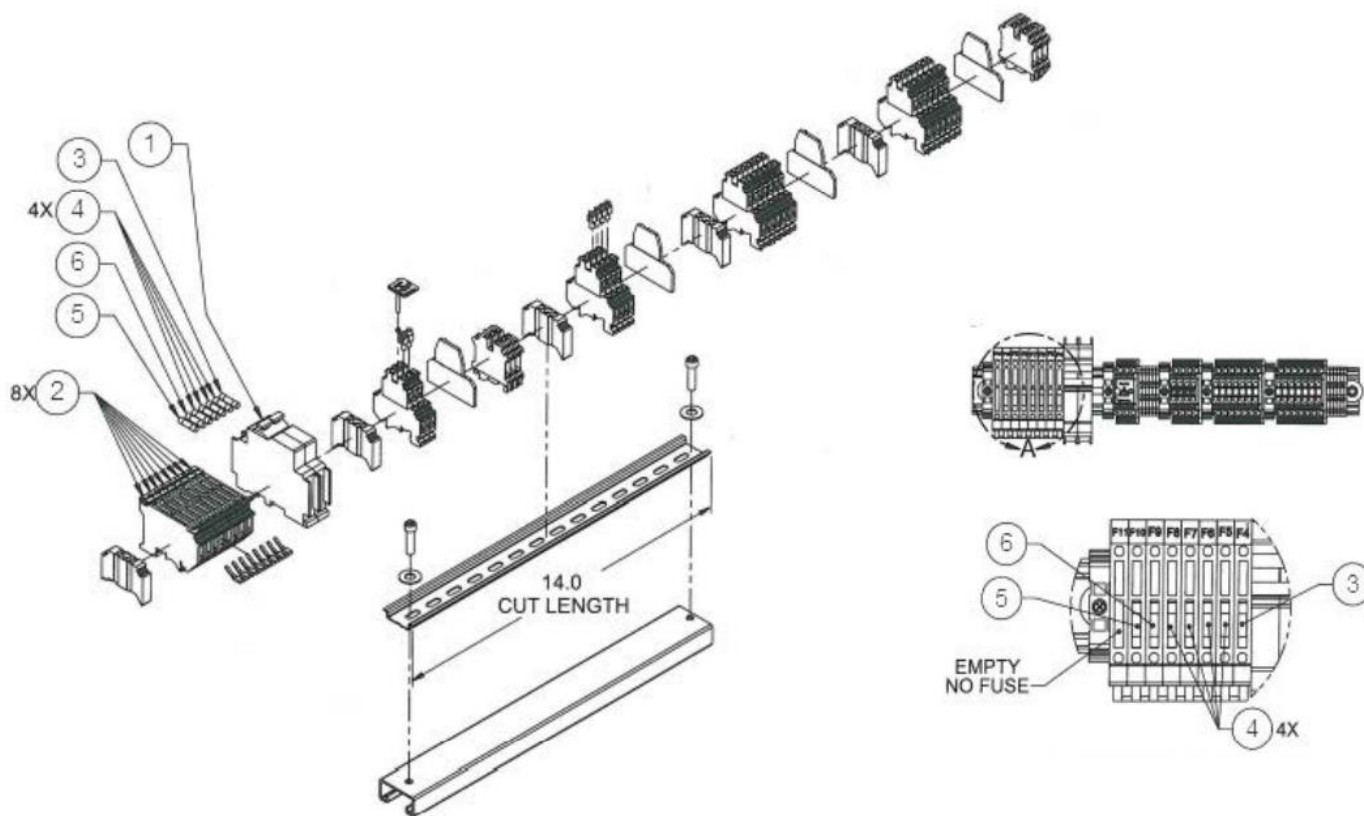
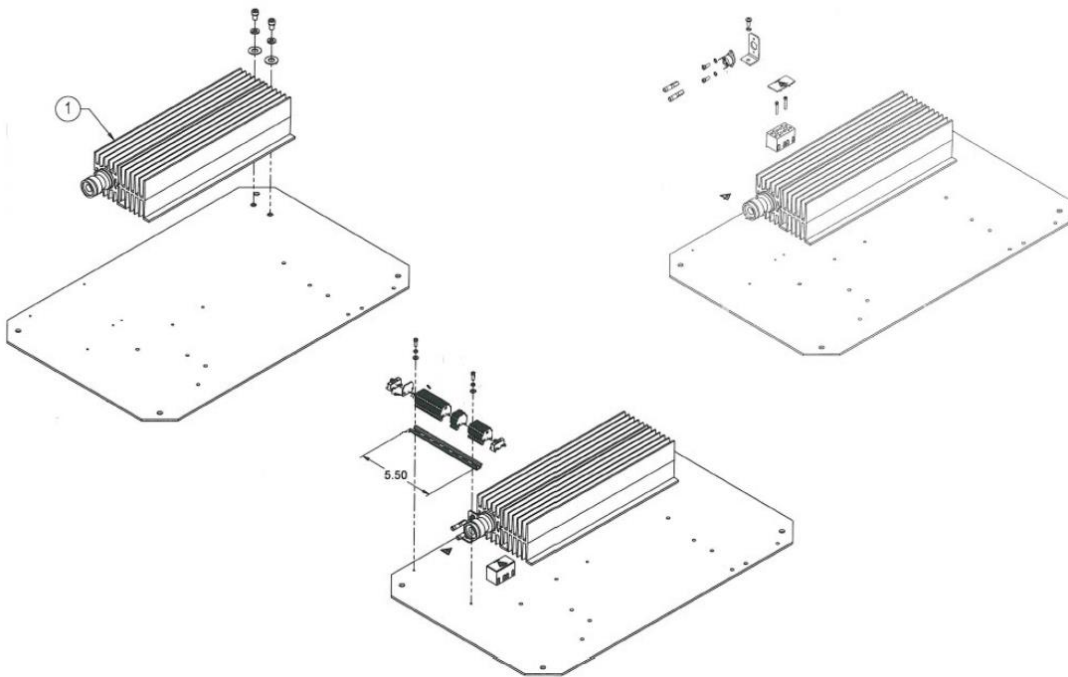


Figure 48. Field interface terminal block assembly

A0055722

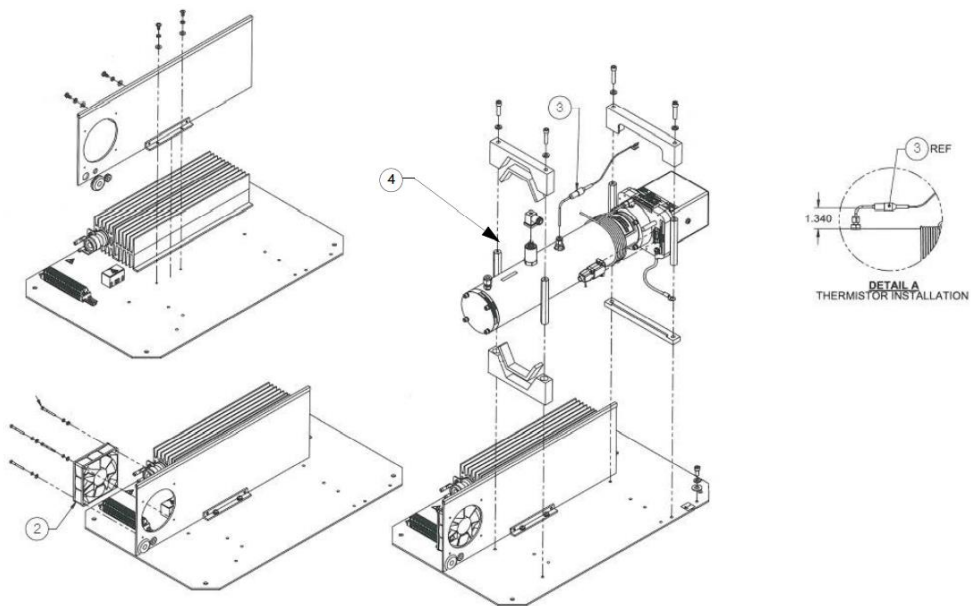
Figure number	Reference number	Material number	Description
Figure 49	1	70156905	Heater, AC 230 V, 200W, EExd IIC T3
		70156906	Heater, AC 120 V, 200W, EExd IIC T3
Figure 50	2	70156876	DC Series Tube axial Cooling Fan, Model: D36T10
Figure 50	3	70156899	Assembly, Thermistor Probe, ATEX
Figure 52	4	70162334	Pressure Sensor, 30 PSIA, 5 V, 1/8 in MNPT DIN4365, NACE ¹

¹ Contact Endress+Hauser Service department before attempting replacement. Replacing this component without Service support could cause damage to other components. For Service, refer to our website for the list of local sales channels in your area (www.endress.com).



A0055723

Figure 49. 8/28 m sample cell panel assembly parts



A0055724

Figure 50. 8/28 m sample cell panel assembly parts (continued)

Figure number	Reference number	Material number	Description
Figure 51	1	70156905	Heater, AC 230 V, 200W, EExd IIC T3
		70156906	Heater, AC 120V, 200W, EExd IIC T3
Figure 52	2	70156876	DC Series Tube axial Cooling Fan, Model: D36T10
Figure 52	3	70162334	Pressure Sensor, 30 PSIA, 5V, 1/8 in MNPT DIN4365, NACE ¹
Figure 52	4	70156901	Assembly, Thermistor Probe, ATEX
Figure 52	5	70156810	Stainless Steel Mirror

¹ Contact Endress+Hauser Service department before attempting replacement. Replacing this component without Service support could cause damage to other components. For Service, refer to our website for the list of local sales channels in your area (www.endress.com).

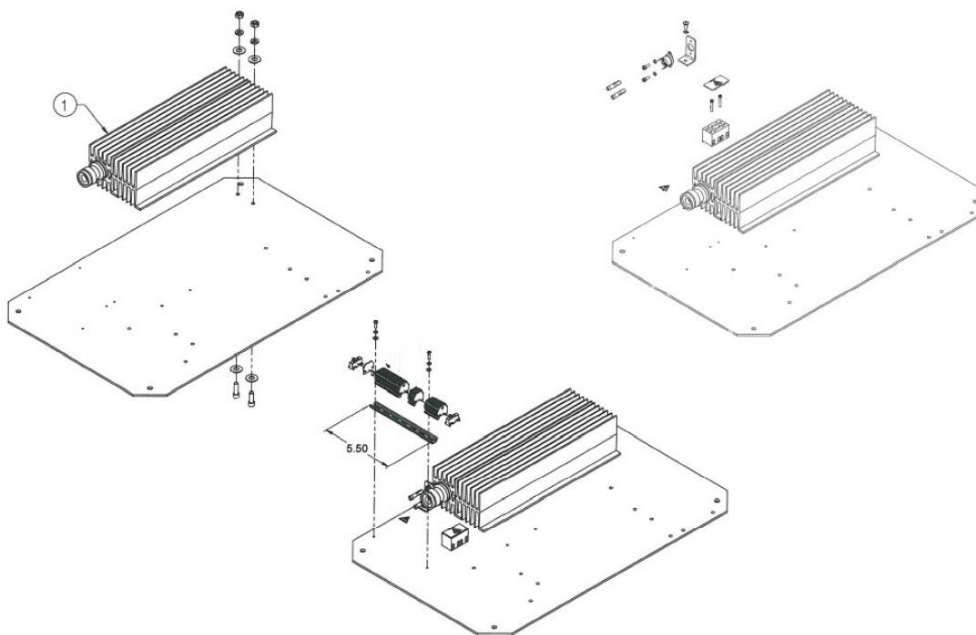


Figure 51. 0.8 m sample cell panel assembly parts

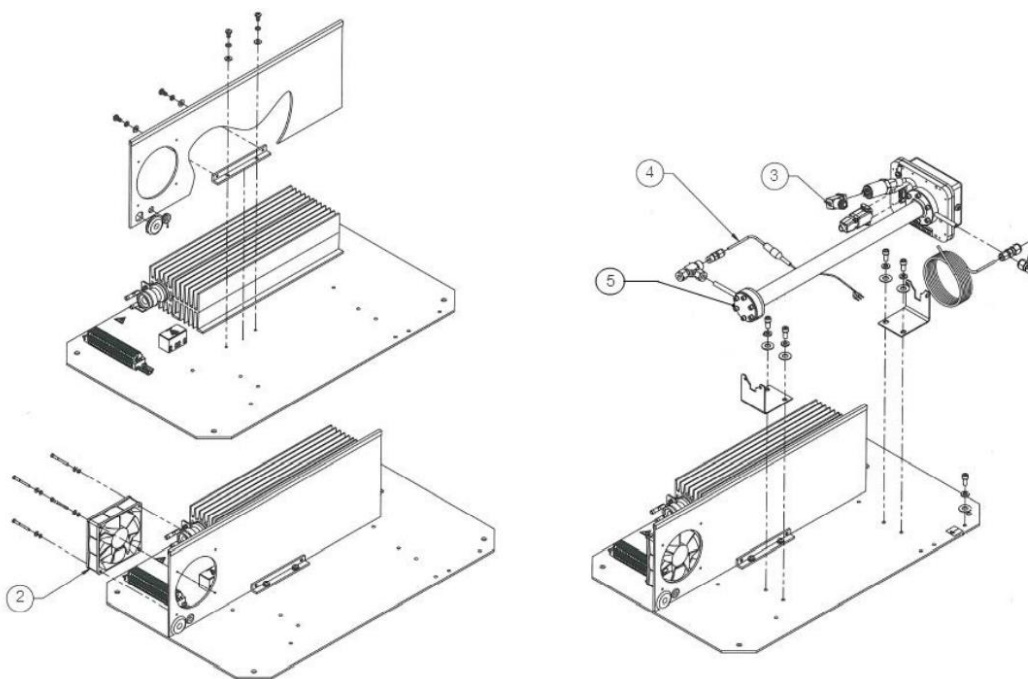


Figure 52. 0.8 m sample cell panel assembly parts (continued)

Figure number	Reference number	Material number	Description
Figure 53	1	70156905	Heater, AC 230 V, 200 W, EExd IIC T3
		70156906	Heater, AC 120 V, 200 W, EExd IIC T3
Figure 54	2	70156876	DC Series Tube axial Cooling Fan, Model: D36T10
Figure 54	3	70162334	Pressure Sensor, 30 PSIA, 5 V, 1/8 in MNPT DIN4365, NACE ¹
Figure 54	4	70156901	Assembly, Thermistor Probe, ATEX
Figure 54	5	70156810	Stainless Steel Mirror

¹ Contact Endress+Hauser Service department before attempting replacement. Replacing this component without Service support could cause damage to other components. For Service, refer to our website for the list of local sales channels in your area (www.endress.com).

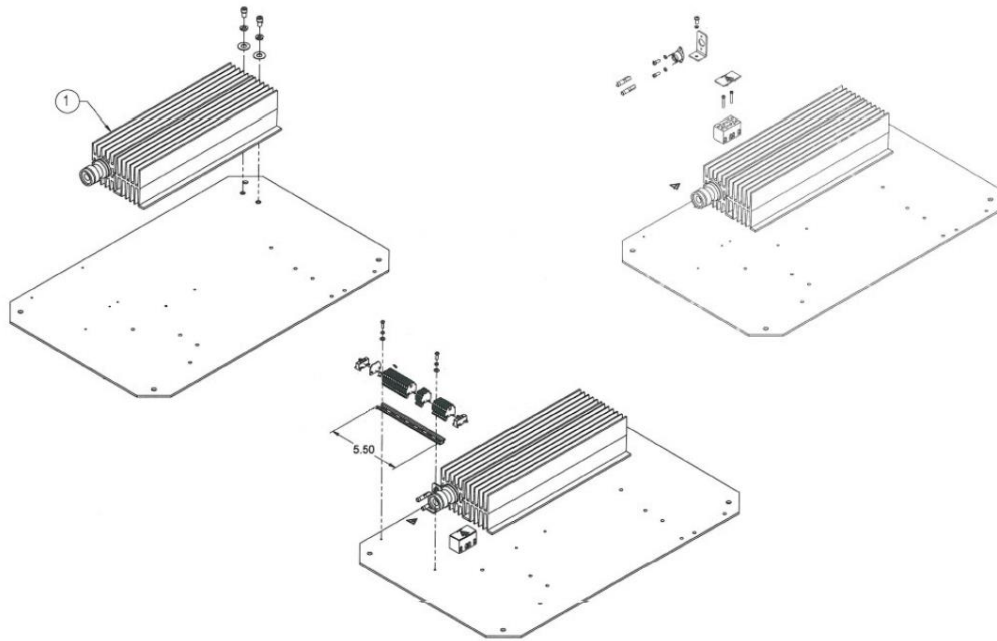


Figure 53. 0.1 m sample cell panel assembly parts

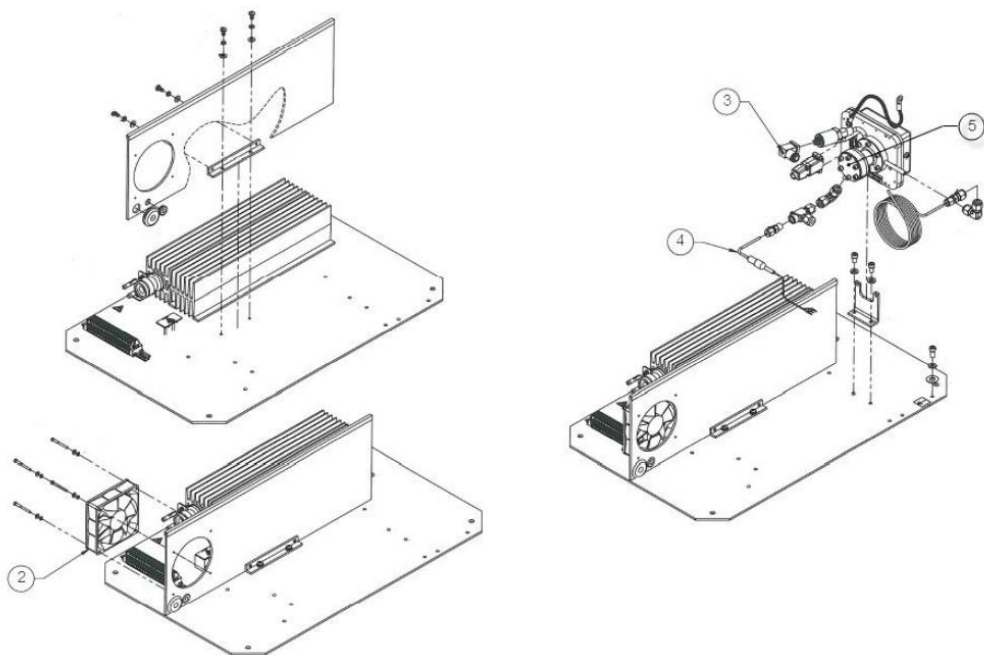


Figure 54. 0.1 m sample cell panel assembly parts (continued)

Figure number	Reference number	Material number	Description
Figure 55	1	70156940	Keypad, Touch Sensitive, 16 Keys

Figure number	Reference number	Material number	Description
Figure 55	2	70159096	Display, LCD, 20X4, Backlit, 5 V, Serial

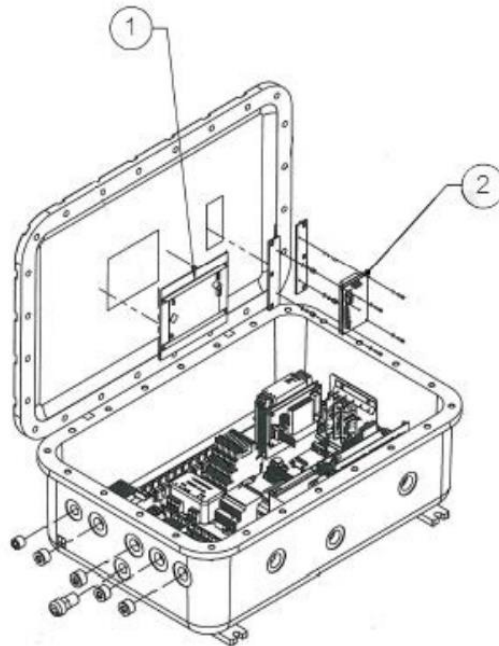


Figure 55. Analyzer electronics enclosure assembly

Material number	Description
70156900	Transition Plate Thermistor
Cables	
70156902	Assembly, Cable, Pressure Sensor, GP50, Cell Enclosure (all cell sizes)
70156903	Cable, Pressure Sensor, GP50, 35 in
70156909	Assembly, Cable, Pressure Sensor, GP50, Electrical Enclosure (to Backplane Connector)
70156907	Assembly, Cable Optical Head, EExd, Electrical Enclosure
70156765	Assembly, Cable, Signal, Optical Head
70156908	Assembly, Cable, Thermistor Cell, Electrical Enclosure
70156911	Assembly, Cable Thermistor Cell, Backplane
70156910	Assembly, Cable, Relay Interface, ARM9 (EExd ENCL)
70156912	Assembly, Ethernet Cable, CAT5e
70156914	Cable, Harness, Signal Output RS-232/4-20 mA
70156920	Cable, Harness, Signal Output RS-232/4-20 mA 25 in
70156924	Assembly, Cable, 4-20 mA Input
70156960	Assembly, Cable, 4-20 mA Output
70156926	Assembly, Cable, AI Jumper, J8 to J4
70156958	Assembly, Cable, RS-232, M-M, Display, Data (EExd)
70156959	Assembly, Cable, Power, Display (EExd)
70156968	Cable, Power Supply Output, 14 in
70162322	Cable, TE Cooler
70156967	Harness, Ribbon, 10 Conductor, 9 in
Scrubber/Indicator (Differential Systems Only)	
70156759	Kit, H2S Scrubber/Indicator, 3 in Diameter
70156758	Kit, H2S Scrubber/Indicator, 2 in Diameter
8000002205 ¹	Kit, NH3 Scrubber/Indicator, 3 in Diameter
70156962	Kit, NH3 Scrubber/Indicator, 2 in Diameter
8000002205 ¹	Kit, HCl Scrubber/Indicator, 3 in Diameter
8000002224 ¹	Kit, HCl Scrubber/Indicator, 2 in Diameter
70175070	Dryer, NuPure
Hardware/Kits	
70156703	Kit, Spares (O-rings, screws), Viton, 8/28 m Cell
70156809	Kit, Spares (O-rings, screws), Viton, 0.8 m Cell
1300002427 ¹	Washer, Sealing, SS, M10
1300002425 ¹	Screw, Socket Head Cap, 304SS, M10x35
1300002426 ¹	Screw, Socket Head Cap, 304SS, M10x30
70162327	Kit, SS2100i-2, M10x35 Bolts and M10 Washer
70156817	Kit, Cleaning Tools, Optical Cell (USA/Canada) ²
70156818	Kit, Cleaning Tools, Optical Cell (International) ²

¹ Non-SAP part number

² Contact Endress+Hauser Service department before attempting replacement. Replacing this component without Service support could cause damage to other components. For Service, refer to our website for the list of local sales channels in your area (www.endress.com).

Material number	Description
1100002156	Tooling Kit (Installation/Maintenance)
General	
BA02197C	SS2100i-2 TDLAS Gas Analyzer Operating Instruction, additional copies
GP01177C	Description of Device Parameters FS 5.16, additional copies
XA02694C	SS2100i-2 TDLAS Gas Analyzer Safety Instruction, additional copies
GP01180C	Description of Device Parameters NS 5.14, additional copies

8 Wiring diagrams

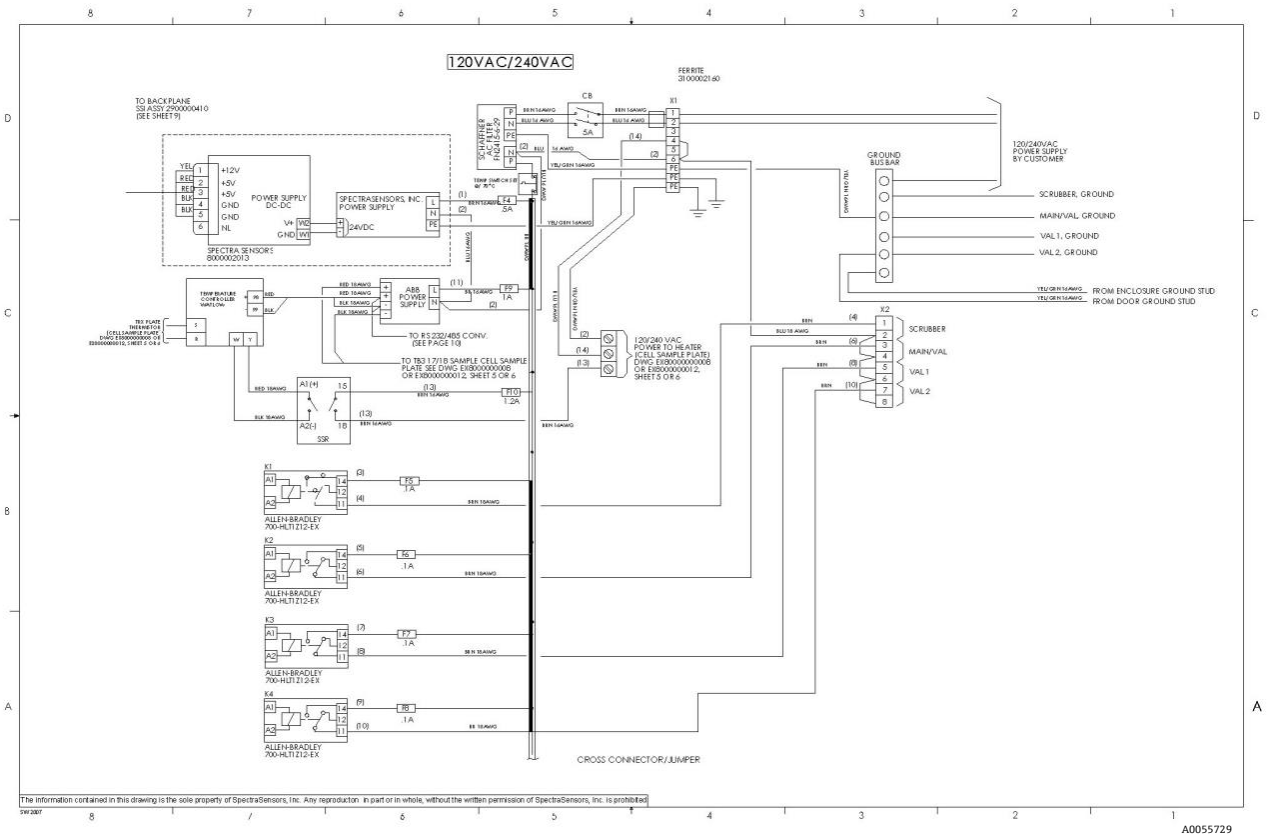


Figure 56. Wiring schematic of SS2100i-2 electronics power systems

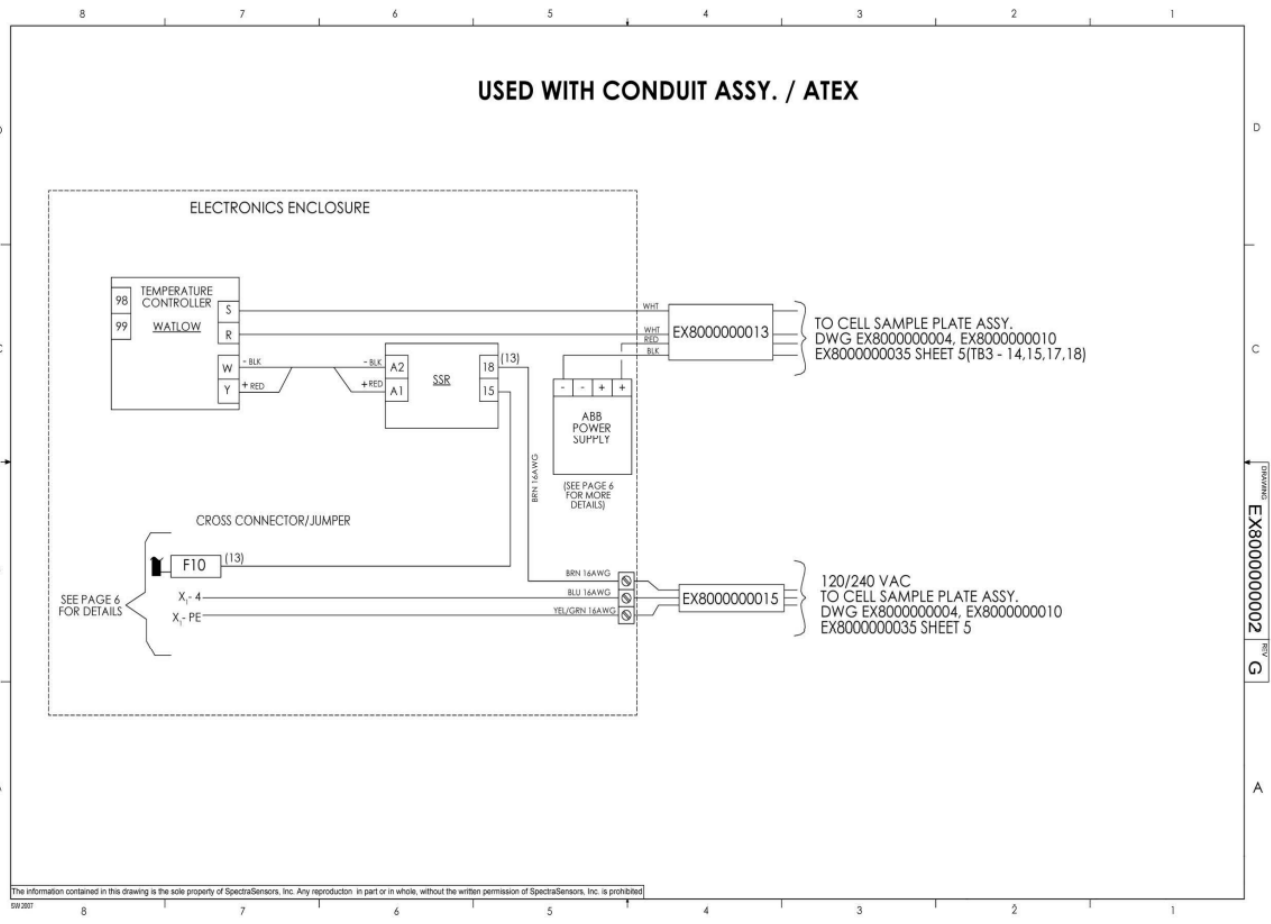


Figure 57. Wiring schematic of conduit-coupled SS2100i-2 power system

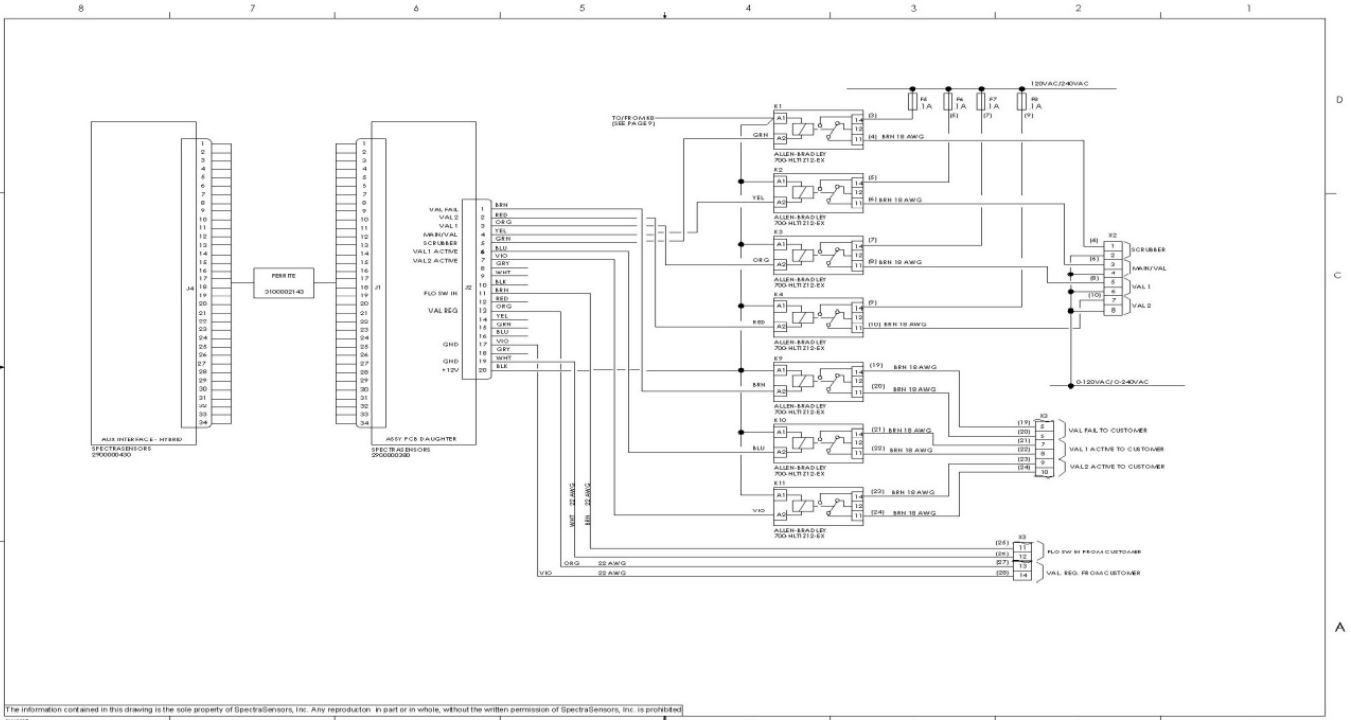


Figure 58. Wiring schematic of SS2100i-2 digital I/O

A0055731

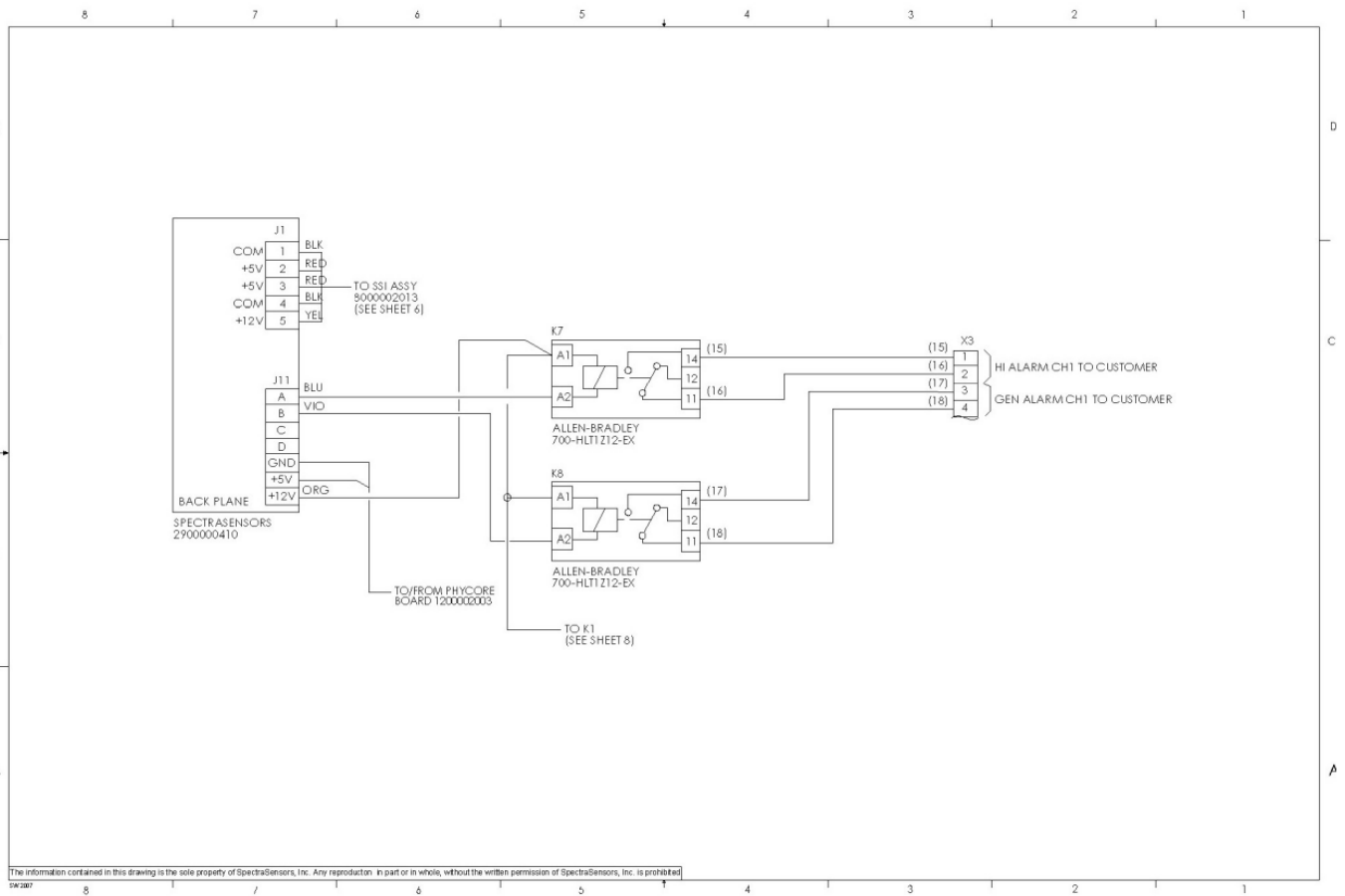


Figure 59. Wiring schematic of SS2100i-2 alarms

A0055732

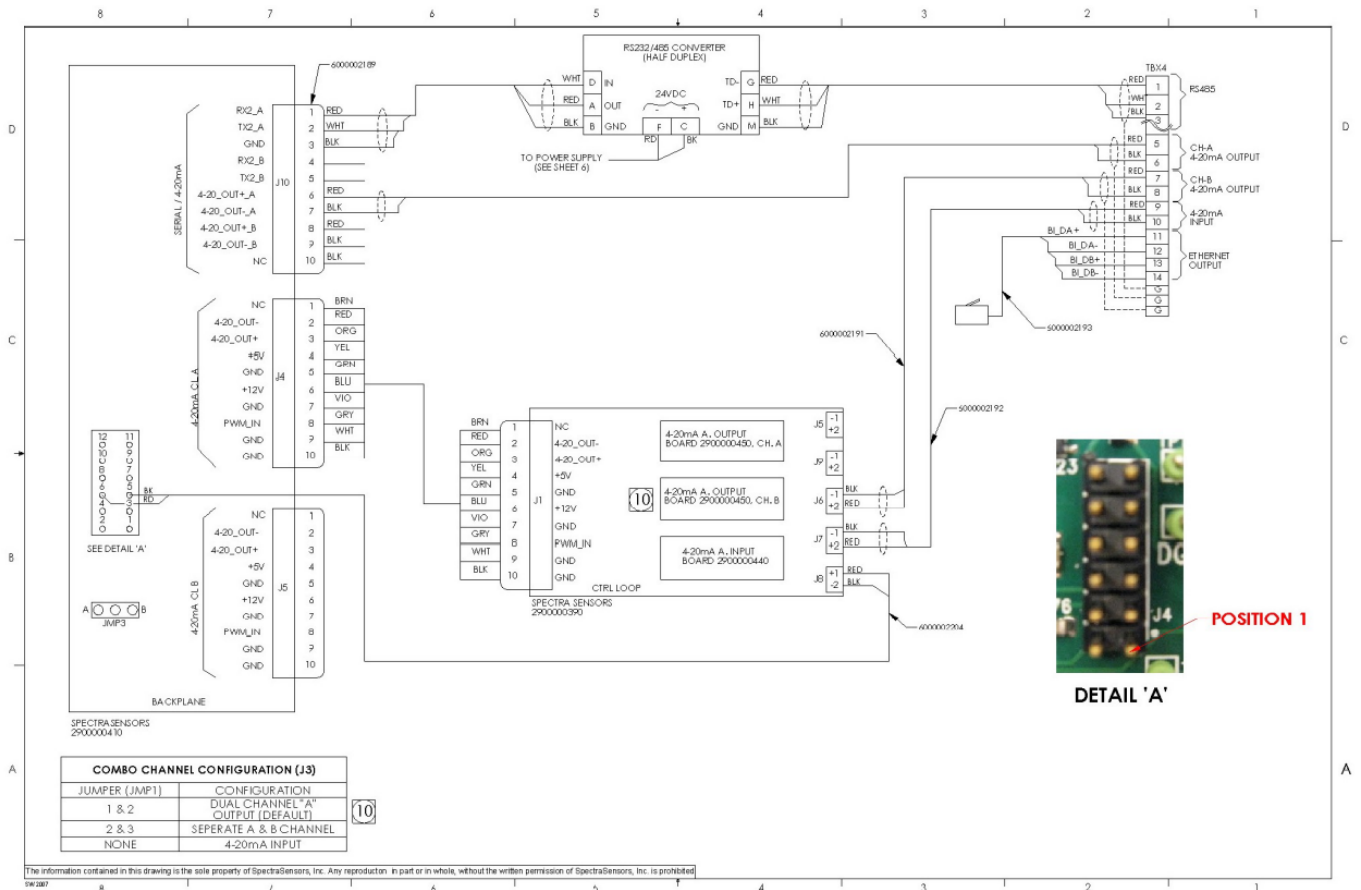


Figure 60. Wiring schematic of SS2100i-2 serial and Ethernet signals

A0055733

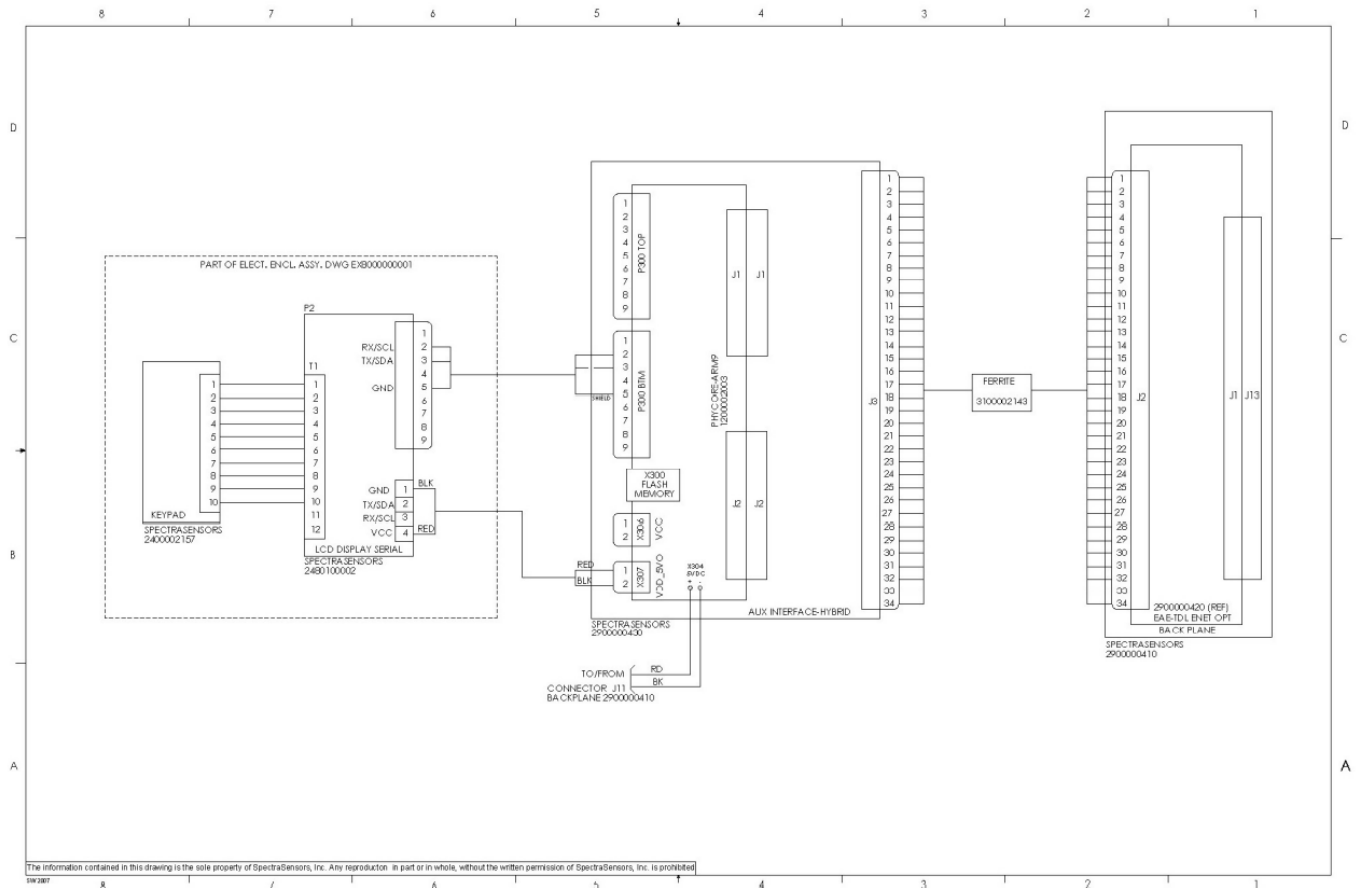


Figure 61. Wiring schematic of SS2100i-2 inter-card connections

A0055734

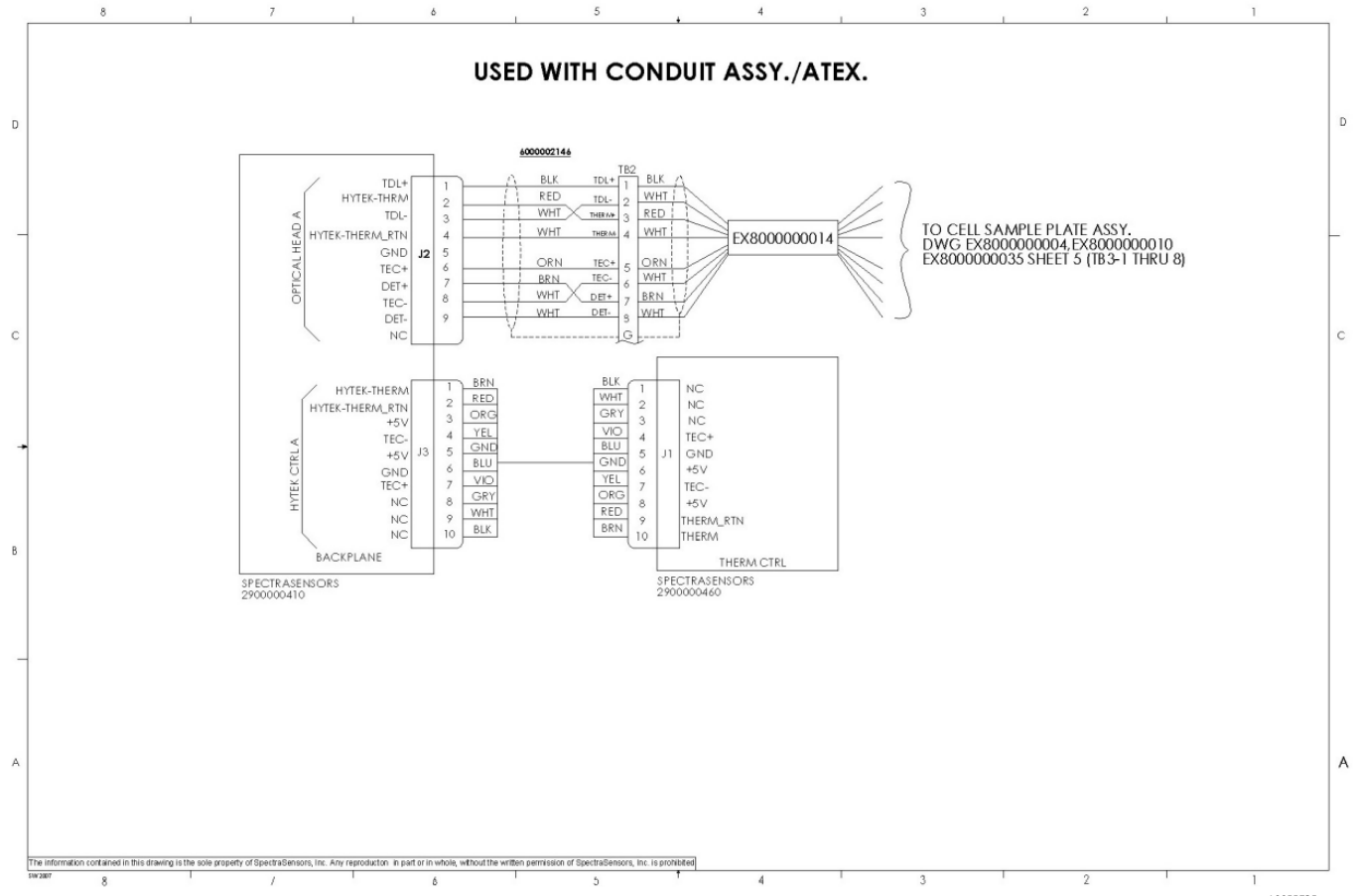


Figure 62. Wiring schematic of conduit-coupled SS2100i-2 optical head connections

A0055735

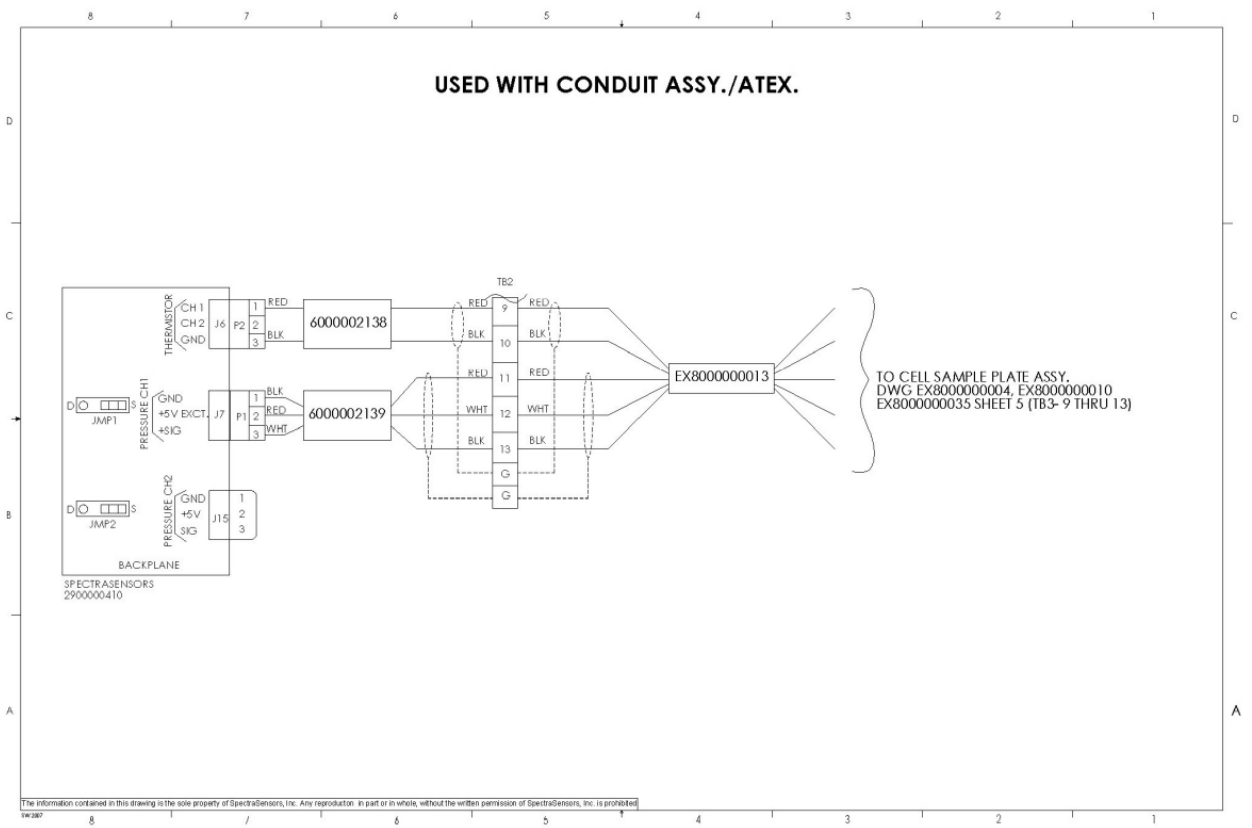


Figure 63. Wiring schematic of conduit-coupled SS2100i-2 pressure and temperature sensor connections

A0055736

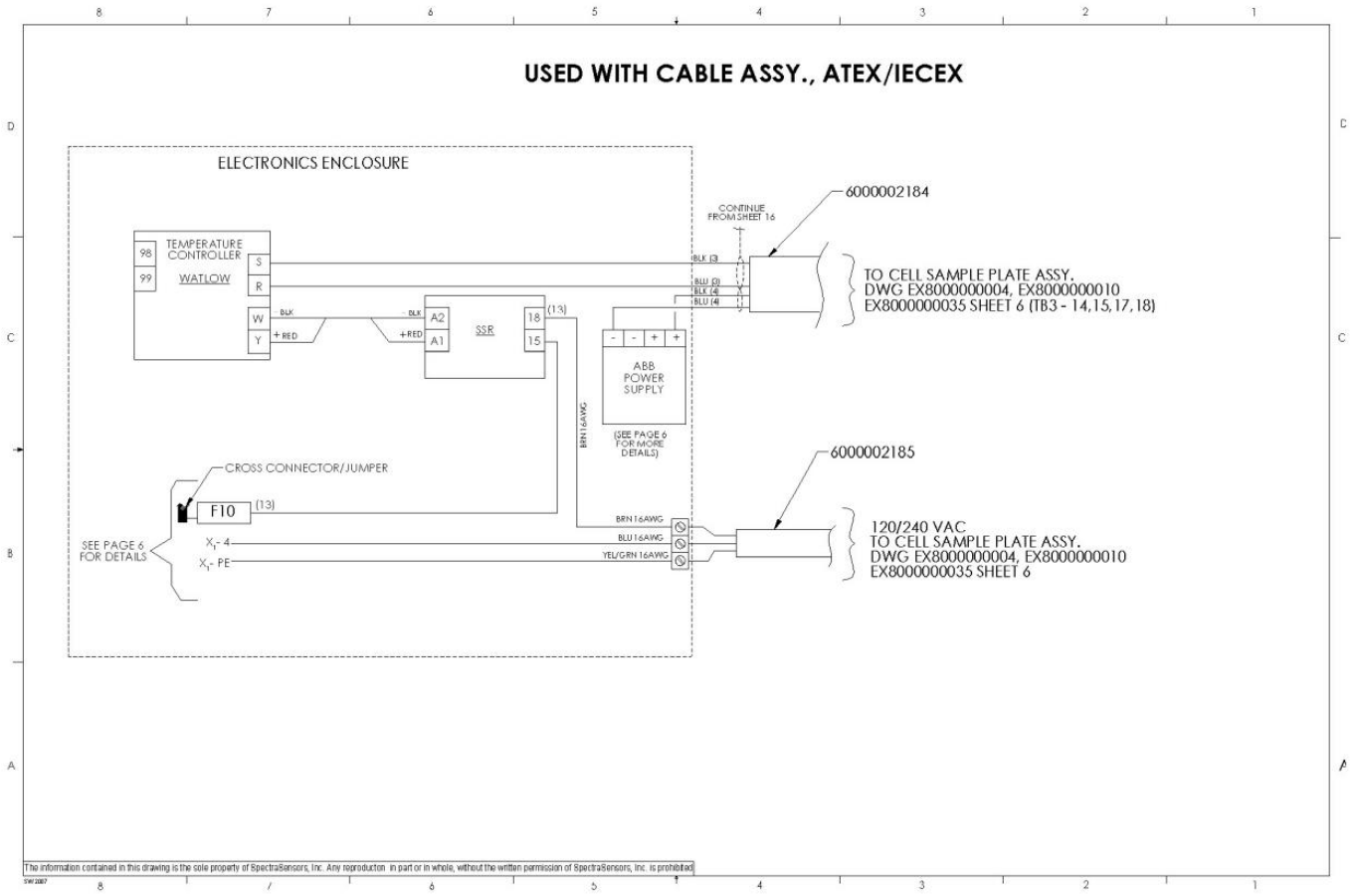


Figure 64. Wiring schematic of cable-coupled SS2100i-2 power system

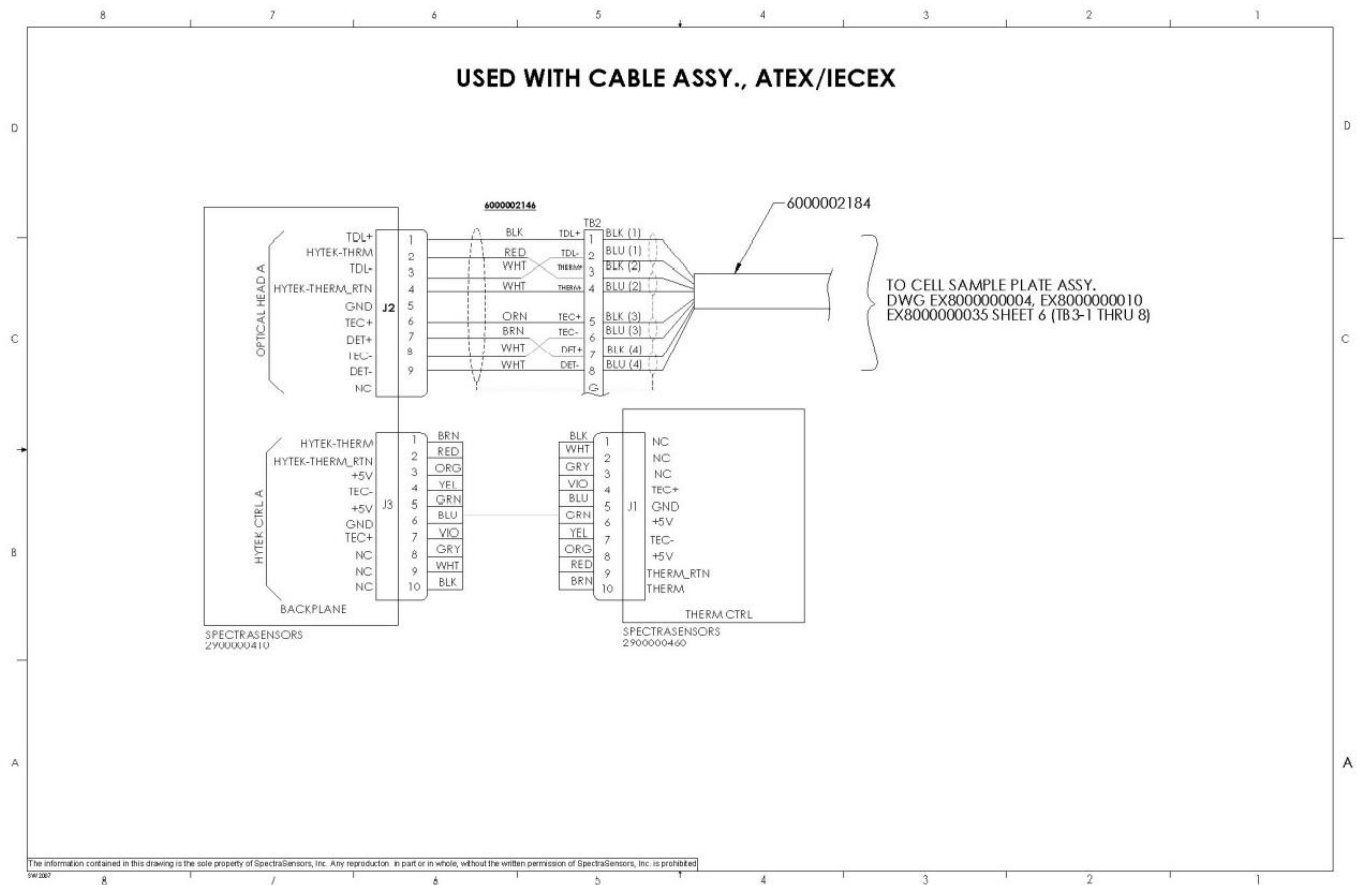


Figure 65. Wiring schematic of cable-coupled SS2100i-2 optical head connections

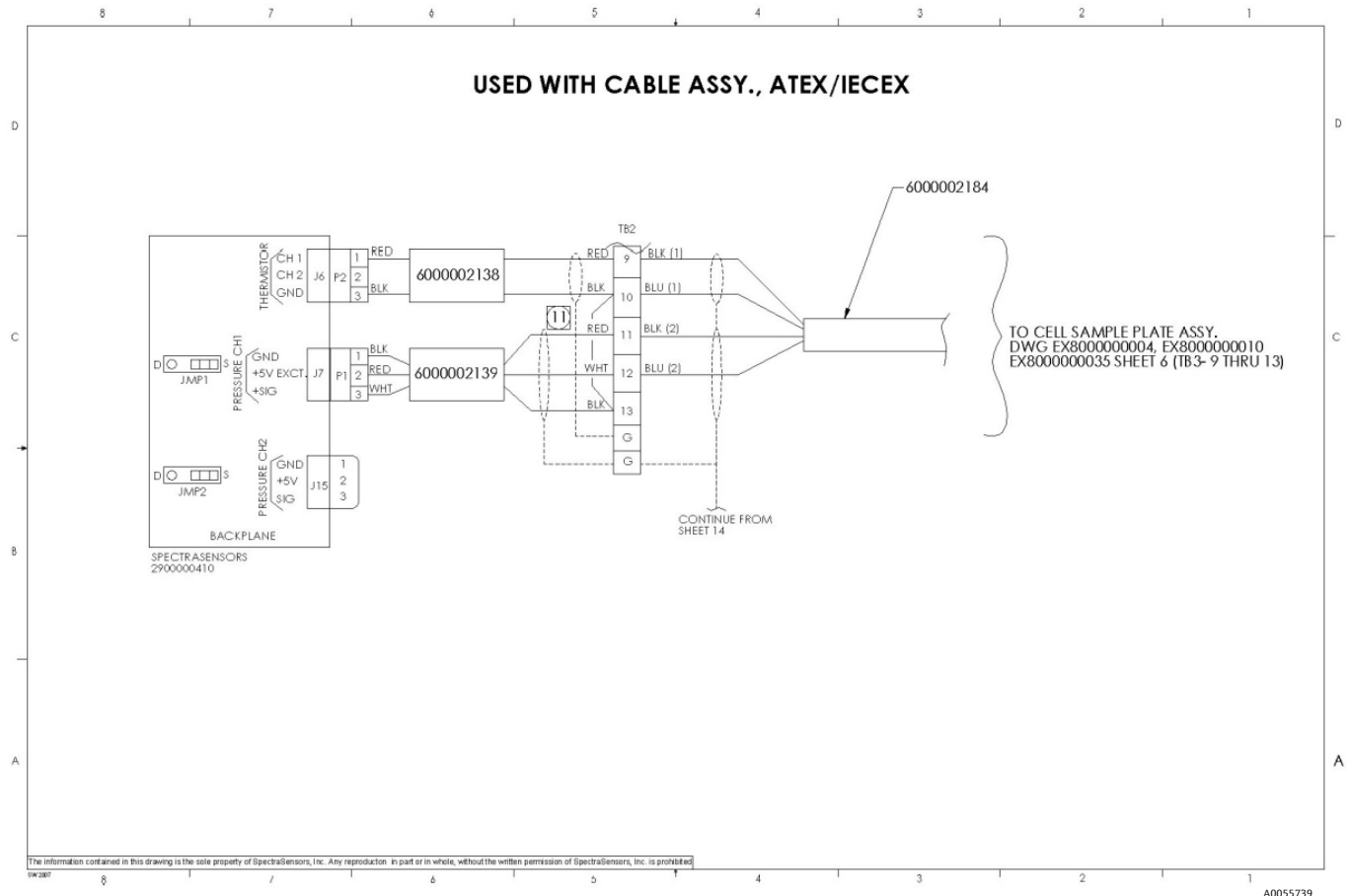


Figure 66. Wiring schematic of cable-coupled SS2100i-2 pressure and temperature sensor

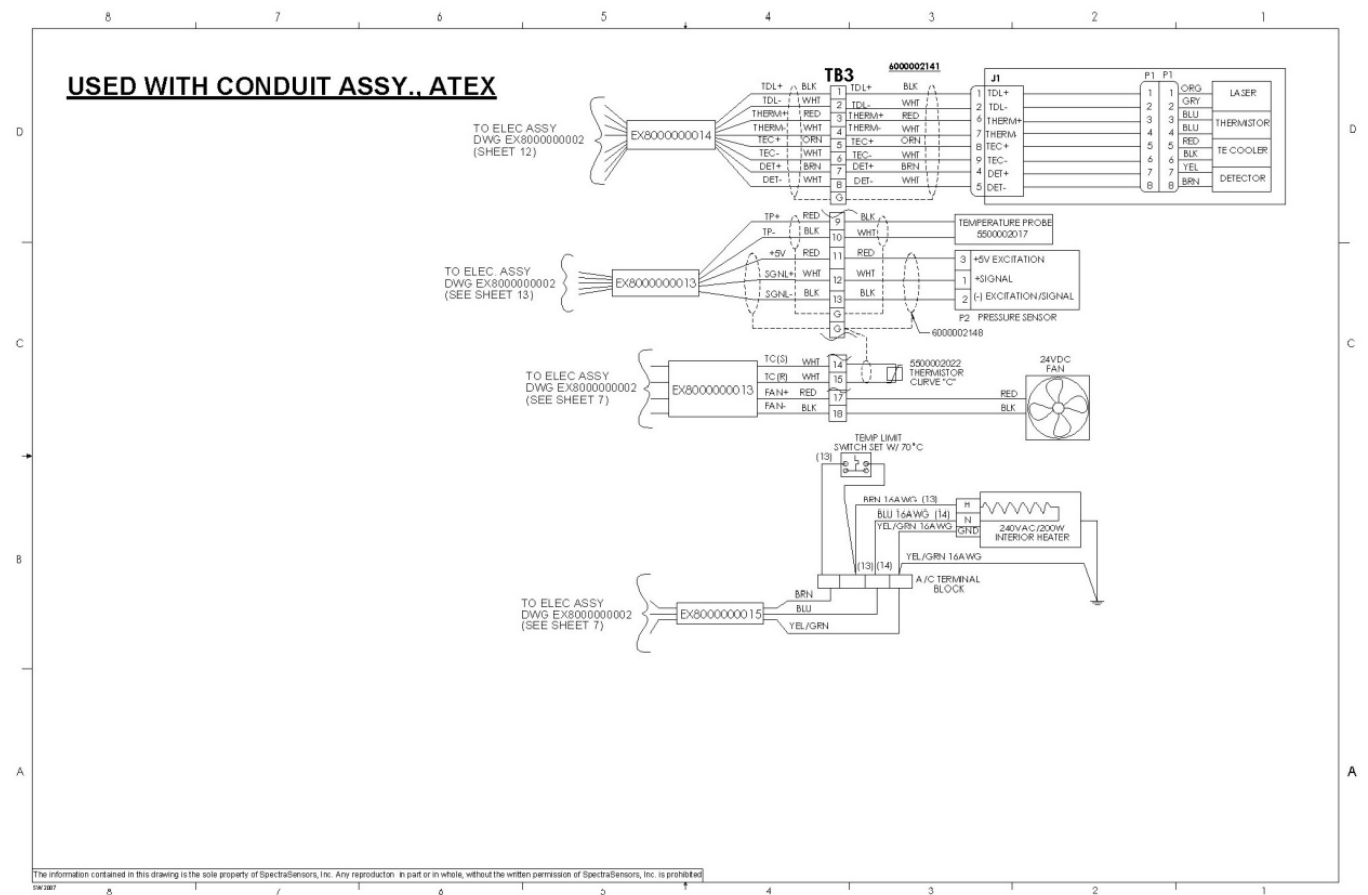


Figure 67. Wiring schematic of conduit-coupled SS2100i-2 sample cell plate connections

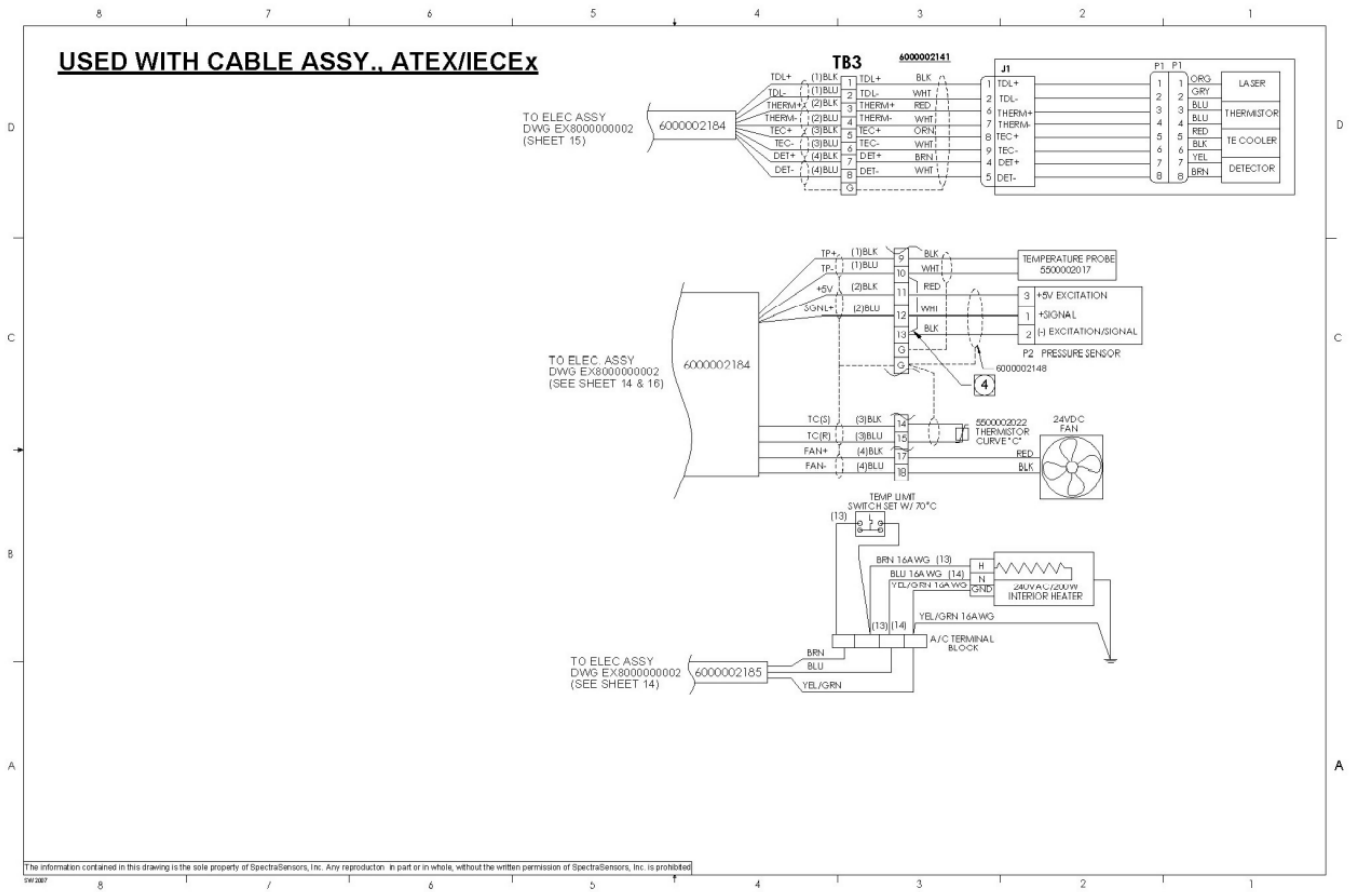


Figure 68. Wiring schematic of cable-coupled SS2100i-2 sample cell plate connections

A0055741

www.addresses.endress.com
