

Installation Instructions

Dummy plug M20×1.5

G $\frac{1}{2}$, NPT $\frac{1}{2}$, NPT $\frac{3}{4}$

Gammapilot, Liquiphant, Micropilot, Prothermo
Cerabar, Deltabar



1 Intended use

- A defective unit can only be replaced with a functioning unit of the same type.
- Use only original parts from Endress+Hauser.
- In the W@M Device Viewer, check if the spare part is suitable for the existing device.

 In some devices, an overview of spare parts is provided inside the device. If the spare part set is listed in the overview, it is not necessary to check the Device Viewer.

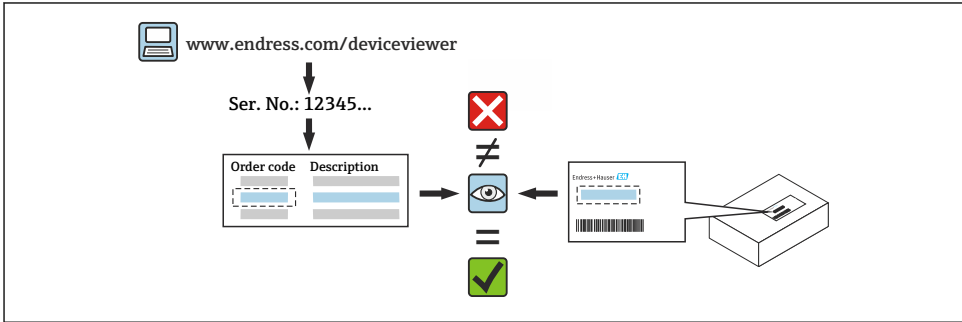

2 Personnel authorized to carry out repairs

Technical staff must comply with the following requirements for repair, mounting, electrical installation and commissioning of the devices:

- Be trained in instrument safety.
- Be familiar with the individual operating conditions of the devices.
- In the case of Ex-certified devices, they must also be trained in explosion protection.

 Technical staff carrying out work are responsible for ensuring that the work is carried out safely and to the required quality standard. They must also guarantee the safety of the device following repair.

3 Safety instructions

- Observe the Operating Instructions for the device.
- Comply with national regulations governing mounting, electrical installation, commissioning, maintenance and repair procedures.
- For devices intended for use in hazardous locations, please observe the instructions in the Ex documentation (XA).
- In the case of devices in safety-related applications in accordance with IEC 61508 or IEC 61511: Commission in accordance with Operating Instructions after repair.
- Before removing the device: set the process to a safe state and purge the pipe of dangerous process substances.

- Risk of burns from hot surfaces! Before commencing work: allow the system and device to cool down to a touchable temperature.
- Risk of damaging electronic components! Ensure that the working environment is protected against electrostatic discharge.
- Modifications to the device are not permitted.
- Observe the instructions for transporting and returning the device outlined in the Operating Instructions.



Contact Endress+Hauser Service if you have questions: www.addresses.endress.com

4 Tools list

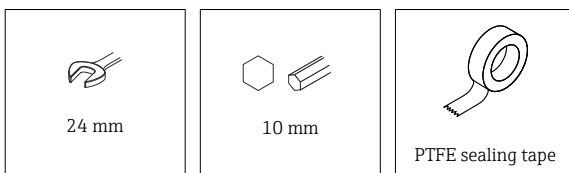

5 Removal

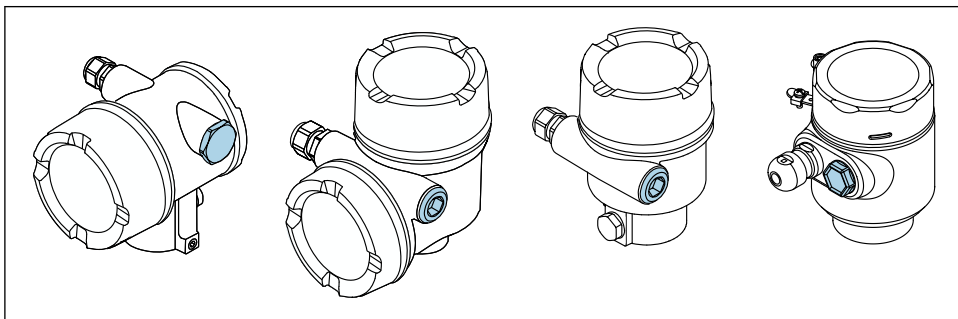

1 Installation positions

5.1 Dummy plug M20×1.5

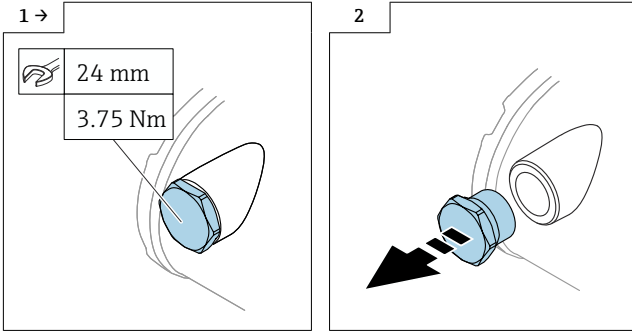

5.2 Dummy plug G $\frac{1}{2}$

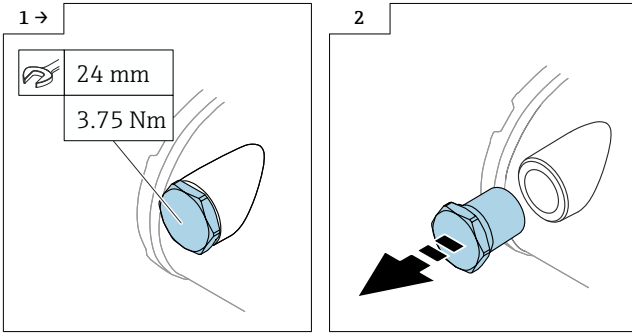

5.3 Dummy plug NPT $\frac{1}{2}$

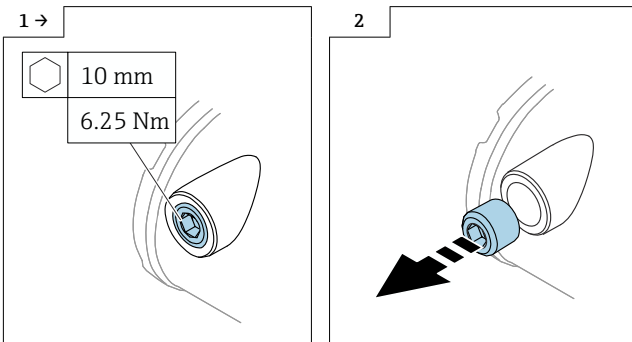

5.4 Dummy plug NPT $\frac{3}{4}$

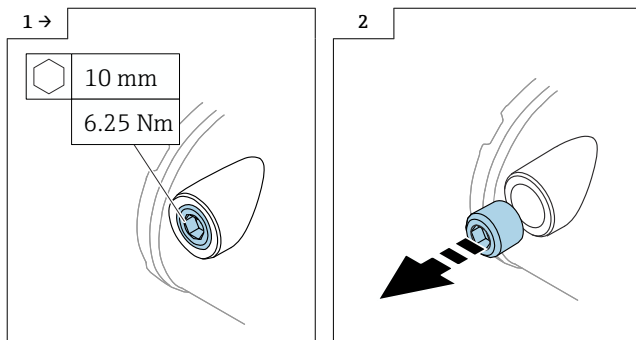



6 Installation

6.1 General installation instructions

Installation is performed by following the removal procedure in reverse order.

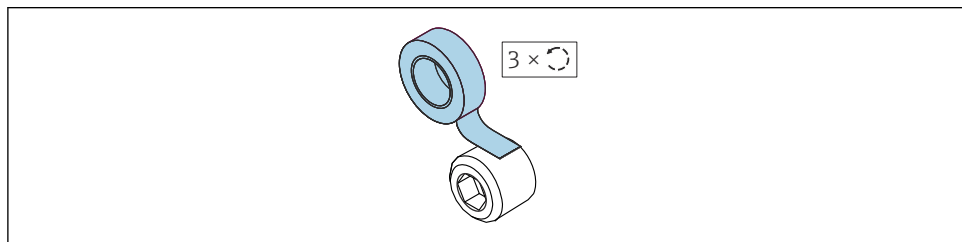
6.2 Special installation instructions



 Only required if dummy plugs NPT $\frac{1}{2}$ and NPT $\frac{3}{4}$ are not pre-assembled with PTFE sealing tape.



71665032

www.addresses.endress.com
