

Technical Information

Proline Promag H 500

Electromagnetic flowmeter



Specialist for hygienic applications, as remote version with up to 4 I/Os

Application

- The bidirectional measuring principle is virtually independent of pressure, density, temperature and viscosity
- For applications with sanitary requirements

Device properties

- Liner made of PFA
- Sensor housing made of stainless steel (3-A, EHEDG)
- Wetted materials CIP-/SIP-cleanable
- Remote version with up to 4 I/Os
- Backlit display with touch control and WLAN access
- Standard cable between sensor and transmitter

Your benefits

- Multivariable measurement for flow, temperature and conductivity
- Flexible installation concept – numerous hygienic process connections
- Energy-saving flow measurement – no pressure loss due to cross section constriction
- Maintenance-free – no moving parts
- Full access to process and diagnostic information – numerous, freely combinable I/Os and Ethernet
- Reduced complexity and variety – freely configurable I/O functionality
- Integrated verification – Heartbeat Technology

Table of contents

About this document	4	Environment	65
Symbols	4	Ambient temperature range	65
Function and system design	5	Storage temperature	66
Measuring principle	5	Atmosphere	66
Measuring system	6	Relative humidity	66
Equipment architecture	8	Operating height	66
Reliability	8	Degree of protection	66
Input	10	Vibration-resistance and shock-resistance	66
Measured variable	10	Internal cleaning	66
Measuring range	10	Mechanical load	66
Operable flow range	12	Electromagnetic compatibility (EMC)	67
Input signal	12	Process	67
Output	14	Medium temperature range	67
Output and input variants	14	Conductivity	68
Output signal	16	Pressure/temperature ratings	68
Signal on alarm	21	Pressure tightness	74
Load	24	Flow limit	74
Ex connection data	24	Pressure loss	74
Low flow cut off	26	System pressure	74
Galvanic isolation	26	Vibrations	74
Protocol-specific data	26	Magnetism and static electricity	74
Power supply	32	Mechanical construction	75
Terminal assignment	32	Dimensions in SI units	75
Available device plugs	33	Dimensions in US units	96
Pin assignment, device plug	34	Weight	111
Supply voltage	36	Measuring tube specification	112
Power consumption	36	Materials	112
Current consumption	36	Fitted electrodes	114
Power supply failure	36	Process connections	114
Overcurrent protection element	36	Surface roughness	115
Electrical connection	37	Operability	115
Terminals	49	Operation concept	115
Cable entries	50	Languages	115
Cable specification	50	Onsite operation	116
Overvoltage protection	55	Remote operation	116
Performance characteristics	55	Service interface	122
Reference operating conditions	55	Network integration	124
Maximum measurement error	55	Supported operating tools	125
Repeatability	57	HistoROM data management	126
Temperature measurement response time	57	Certificates and approvals	128
Influence of ambient temperature	57	CE mark	128
Mounting	57	UKCA marking	128
Mounting location	57	RCM marking	128
Orientation	60	Ex approval	128
Inlet and outlet runs	61	Sanitary compatibility	131
Adapters	61	Pharmaceutical compatibility	131
Length of connecting cable	62	Functional safety	131
Mounting the transmitter housing	63	HART certification	132
Special mounting instructions	65	FOUNDATION Fieldbus certification	132
		Certification PROFIBUS	132
		EtherNet/IP certification	132
		Certification PROFINET	132
		PROFINET with Ethernet-APL certification	133
		Radio approval	133

Pressure Equipment Directive	133
Additional certification	133
External standards and guidelines	133
Ordering information	134
Application packages	134
Diagnostic functionality	134
Heartbeat Technology	134
Cleaning	135
OPC-UA Server	135
Accessories	135
Device-specific accessories	136
Communication-specific accessories	137
Service-specific accessories	138
System components	139
Supplementary documentation	139
Standard documentation	139
Supplementary device-dependent documentation	140
Registered trademarks	141

About this document

Symbols

Electrical symbols

Symbol	Meaning
	Direct current
	Alternating current
	Direct current and alternating current
	Ground connection A grounded terminal which, as far as the operator is concerned, is grounded via a grounding system.
	Potential equalization connection (PE: protective earth) Ground terminals that must be connected to ground prior to establishing any other connections. The ground terminals are located on the interior and exterior of the device: <ul style="list-style-type: none"> ▪ Interior ground terminal: potential equalization is connected to the supply network. ▪ Exterior ground terminal: device is connected to the plant grounding system.

Communication-specific symbols

Symbol	Meaning
	Wireless Local Area Network (WLAN) Communication via a wireless, local network.

Symbols for certain types of information

Symbol	Meaning
	Permitted Procedures, processes or actions that are permitted.
	Preferred Procedures, processes or actions that are preferred.
	Forbidden Procedures, processes or actions that are forbidden.
	Tip Indicates additional information.
	Reference to documentation
	Reference to page
	Reference to graphic
	Visual inspection

Symbols in graphics

Symbol	Meaning
1, 2, 3, ...	Item numbers
1 , 2 , 3 , ...	Series of steps
A, B, C, ...	Views
A-A, B-B, C-C, ...	Sections

Symbol	Meaning
	Hazardous area
	Safe area (non-hazardous area)
	Flow direction

Function and system design

Measuring principle

Following *Faraday's law of magnetic induction*, a voltage is induced in a conductor moving through a magnetic field.

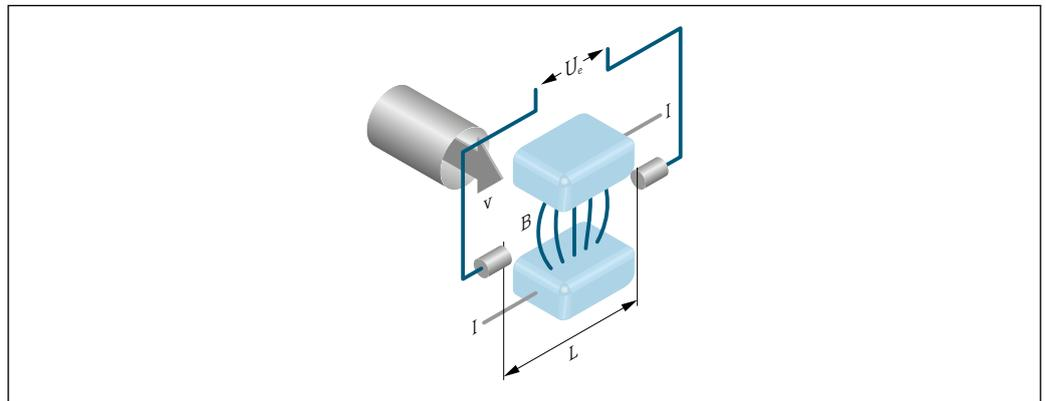

- U_e Induced voltage
 B Magnetic induction (magnetic field)
 L Electrode spacing
 I Current
 v Flow velocity

In the electromagnetic measuring principle, the flowing medium is the moving conductor. The voltage induced (U_e) is proportional to the flow velocity (v) and is supplied to the amplifier by means of two measuring electrodes. The flow volume (Q) is calculated via the pipe cross-section (A). The magnetic field is created through a switched direct current of alternating polarity.

Formulae for calculation

- Induced voltage $U_e = B \cdot L \cdot v$
- Volume flow $Q = A \cdot v$

Measuring system

The measuring system consists of a transmitter and a sensor. The transmitter and sensor are mounted in physically separate locations. They are interconnected by connecting cables.

Transmitter

Two versions of the transmitter are available.

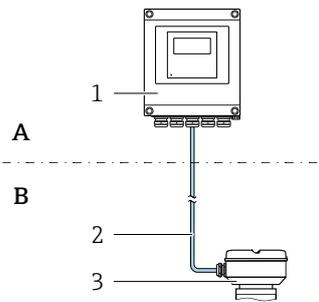
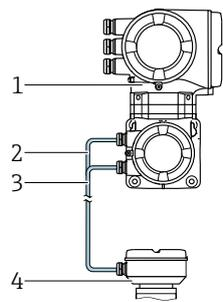
Proline 500 – digital	Proline 500
<p>For use in applications not required to meet special requirements due to ambient or operating conditions.</p>  <p>A</p> <p>B</p> <p>1 Transmitter</p> <p>2 Connecting cable: cable, separate, standard</p> <p>3 Sensor connection housing with integrated ISEM</p> <ul style="list-style-type: none"> Flexible and cost-effective separate installation. A standard cable can be used as the connecting cable. Electronics in the transmitter housing, ISEM (intelligent sensor electronics module) in the sensor connection housing Signal transmission: digital Order code for "Integrated ISEM electronics", option A "Sensor" 	<p>For use in applications required to meet special requirements due to ambient or operating conditions.</p>  <p>1 Transmitter with integrated ISEM</p> <p>2 Coil current cable</p> <p>3 Signal cable</p> <p>4 Sensor connection housing</p> <ul style="list-style-type: none"> Electronics and ISEM (intelligent sensor electronics module) in the transmitter housing Signal transmission: analog Order code for "Integrated ISEM electronics", option B "Transmitter"
<p>Connecting cable (can be ordered in various lengths → 📄 136)</p> <ul style="list-style-type: none"> Length: max. 300 m (1000 ft) Standard cable with common shield (pair-stranded) Not sensitive to external EMC interference. 	
<p>Hazardous area</p> <p>Use in: Zone 2; Class I, Division 2</p> <p>Mixed installation is possible:</p> <ul style="list-style-type: none"> Sensor: Zone 1; Class I, Division 1 Transmitter: Zone 2; Class I, Division 2 	
<p>Housing versions and materials</p> <ul style="list-style-type: none"> Transmitter housing <ul style="list-style-type: none"> Aluminum, coated: aluminum, AlSi10Mg, coated Material: polycarbonate Material of window in transmitter housing <ul style="list-style-type: none"> Aluminum, coated: glass Polycarbonate: plastic 	
<p>Configuration</p> <ul style="list-style-type: none"> External operation via 4-line, illuminated graphic local display (LCD) with touch control and guided menus ("Make-it-run" wizards) for application-specific commissioning. Via service interface or WLAN interface: <ul style="list-style-type: none"> Operating tools (e.g. FieldCare, DeviceCare) Web server (access via Web browser, e.g. Microsoft Internet Explorer, Microsoft Edge) 	

Sensor connection housing

Different versions of the connection housing are available.

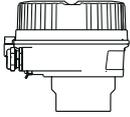
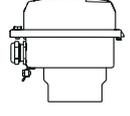
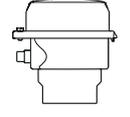
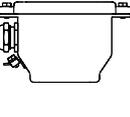
	<p>Order code for "Sensor connection housing", option A, "Aluminum, coated": Aluminum, AlSi10Mg, coated</p> <p> This device version is only available in conjunction with the Proline 500 – digital transmitter.</p>
	<p>Order code for "Sensor connection housing", option B, "Stainless": Hygienic version, stainless steel 1.4301 (304)</p> <p> This device version is only available in conjunction with the Proline 500 – digital transmitter.</p>
	<p>Order code for "Sensor connection housing", option C, "Ultra-compact hygienic, stainless": Hygienic version, stainless steel 1.4301 (304)</p> <p> This device version is only available in conjunction with the Proline 500 – digital transmitter.</p>
 <p style="text-align: right; font-size: small;">A0029683</p>	<p>Order code for "Sensor connection housing", option B, "Stainless, hygienic": Hygienic version, stainless steel 1.4301 (304)</p> <p> This device version is only available in conjunction with the Proline 500 transmitter.</p>

Sensor

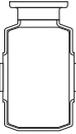
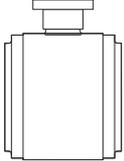
<p>Promag H</p>  <p style="text-align: right; font-size: small;">A0019897</p>  <p style="text-align: right; font-size: small;">A0019898</p>	<p>Nominal diameter range: DN 2 to 150 (1/12 to 6")</p> <p>Materials:</p> <ul style="list-style-type: none"> ■ Sensor housing: stainless steel, 1.4301 (304) ■ Measuring tubes: stainless steel, 1.4301 (304) ■ Liner: PFA ■ Electrodes: stainless steel, 1.4435 (316L); Alloy C22, 2.4602 (UNS N06022); tantalum; platinum (only up to DN 25 (1")) ■ Process connections: stainless steel, 1.4404 (F316L); PVDF; PVC adhesive sleeve ■ Seals: <ul style="list-style-type: none"> ■ DN 2 to 25 (1/12 to 1"): O-ring seal (EPDM, FKM, Kalrez), aseptic gasket seal (EPDM, FKM, silicone) ■ DN 40 to 150 (1 1/2 to 6"): aseptic gasket seal (EPDM, FKM, silicone) ■ Grounding rings: stainless steel, 1.4435 (316L); Alloy C22, 2.4602 (UNS N06022); tantalum
--	---

Equipment architecture

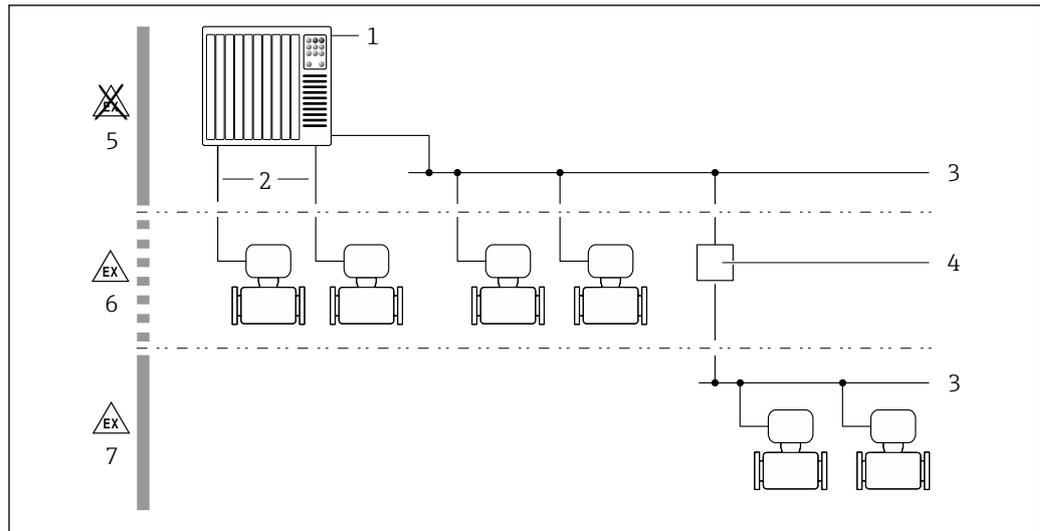

A0027512

1 Possibilities for integrating measuring devices into a system

- 1 Control system (e.g. PLC)
- 2 Connecting cable (0/4 to 20 mA HART etc.)
- 3 Fieldbus
- 4 Coupler
- 5 Non-hazardous area
- 6 Hazardous area: Zone 2; Class I, Division 2
- 7 Hazardous area: Zone 1; Class I, Division 1

Reliability

IT security

Our warranty is valid only if the product is installed and used as described in the Operating Instructions. The product is equipped with security mechanisms to protect it against any inadvertent changes to the settings.

IT security measures, which provide additional protection for the product and associated data transfer, must be implemented by the operators themselves in line with their security standards.

Device-specific IT security

The device offers a range of specific functions to support protective measures on the operator's side. These functions can be configured by the user and guarantee greater in-operation safety if used correctly. The following list provides an overview of the most important functions:

Function/interface	Factory setting	Recommendation
Write protection via hardware write protection switch → 9	Not enabled	On an individual basis following risk assessment
Access code (also applies to web server login or FieldCare connection) → 9	Not enabled (0000)	Assign a customized access code during commissioning
WLAN (order option in display module)	Enabled	On an individual basis following risk assessment
WLAN security mode	Enabled (WPA2-PSK)	Do not change
WLAN passphrase (Password) → 9	Serial number	Assign an individual WLAN passphrase during commissioning
WLAN mode	Access point	On an individual basis following risk assessment
Web server → 9	Enabled	On an individual basis following risk assessment
Service interface CDI-RJ45 → 10	-	On an individual basis following risk assessment

Protecting access via hardware write protection

Write access to the parameters of the device via the local display, web browser or operating tool (e.g. FieldCare, DeviceCare) can be disabled via a write protection switch (DIP switch on the main electronics module). When hardware write protection is enabled, only read access to the parameters is possible.

Hardware write protection is disabled when the device is delivered.

Protecting access via a password

Different passwords are available to protect write access to the device parameters or access to the device via the WLAN interface.

- **User-specific access code**
Protect write access to the device parameters via the local display, web browser or operating tool (e.g. FieldCare, DeviceCare). Access authorization is clearly regulated through the use of a user-specific access code.
- **WLAN passphrase**
The network key protects a connection between an operating unit (e.g. notebook or tablet) and the device via the WLAN interface which can be ordered as an option.
- **Infrastructure mode**
When the device is operated in infrastructure mode, the WLAN passphrase corresponds to the WLAN passphrase configured on the operator side.

User-specific access code

Write access to the device parameters via the local display, web browser or operating tool (e.g. FieldCare, DeviceCare) can be protected by the modifiable, user-specific access code.

WLAN passphrase: Operation as WLAN access point

A connection between an operating unit (e.g. notebook or tablet) and the device via the WLAN interface, which can be ordered as an optional extra, is protected by the network key. The WLAN authentication of the network key complies with the IEEE 802.11 standard.

When the device is delivered, the network key is pre-defined depending on the device. It can be changed via the **WLAN settings** submenu in the **WLAN passphrase** parameter.

Infrastructure mode

A connection between the device and WLAN access point is protected by means of an SSID and passphrase on the system side. Please contact the relevant system administrator for access.

General notes on the use of passwords

- The access code and network key supplied with the device should be changed during commissioning for safety reasons.
- Follow the general rules for generating a secure password when defining and managing the access code and network key.
- The user is responsible for the management and careful handling of the access code and network key.

Access via web server

The device can be operated and configured via a web browser with the integrated web server. The connection is established via the service interface (CDI-RJ45) or the WLAN interface. For device versions with the EtherNet/IP and PROFINET communication protocols, the connection can also be established via the terminal connection for signal transmission with EtherNet/IP, PROFINET (RJ45 plug) or PROFINET with Ethernet-APL (two-wire).

The web server is enabled when the device is delivered. The web server can be disabled via the **Web server functionality** parameter if necessary (e.g., after commissioning).

The device and status information can be hidden on the login page. This prevents unauthorized access to the information.



Detailed information on the device parameters:
"Description of device parameters" document .

Access via OPC-UA

 The "OPC UA Server" application package is available in the device version with the HART communication protocol →  135.

The device can communicate with OPC UA clients using the "OPC UA Server" application package.

The OPC UA server integrated in the device can be accessed via the WLAN access point using the WLAN interface - which can be ordered as an optional extra - or the service interface (CDI- RJ45) via Ethernet network. Access rights and authorization as per separate configuration.

The following Security Modes are supported as per the OPC UA Specification (IEC 62541):

- None
- Basic128Rsa15 – signed
- Basic128Rsa15 – signed and encrypted

Access via service interface (CDI-RJ45)

The device can be connected to a network via the service interface (CDI-RJ45). Device-specific functions guarantee the secure operation of the device in a network.

The use of relevant industrial standards and guidelines that have been defined by national and international safety committees, such as IEC/ISA62443 or the IEEE, is recommended. This includes organizational security measures such as the assignment of access authorization as well as technical measures such as network segmentation.

 Transmitters with an Ex de approval may not be connected via the service interface (CDI-RJ45)!
Order code for "Approval transmitter + sensor", options (Ex de): BA, BB, C1, C2, GA, GB, MA, MB, NA, NB BB, C2, GB, MB, NB

 The device can be integrated into a ring topology. The device is integrated via the terminal connection for signal transmission (output 1) and the connection to the service interface (CDI-RJ45) →  122.

Input

Measured variable

Direct measured variables

- Volume flow (proportional to induced voltage)
- Temperature ¹⁾
- Electrical conductivity

Calculated measured variables

- Mass flow
- Corrected volume flow
- Corrected electrical conductivity ¹⁾

Measuring range

Typically $v = 0.01$ to 10 m/s (0.03 to 33 ft/s) with the specified accuracy

Flow characteristic values in SI units: DN 2 to 125 ($1/12$ to 5")

Nominal diameter		Recommended flow min./max. full scale value ($v \sim 0.3/10$ m/s) [dm ³ /min]	Factory settings		
[mm]	[in]		Full scale value current output ($v \sim 2.5$ m/s) [dm ³ /min]	Pulse value (~ 2 pulse/s) [dm ³]	Low flow cut off ($v \sim 0.04$ m/s) [dm ³ /min]
2	$1/12$	0.06 to 1.8	0.5	0.005	0.01
4	$5/32$	0.25 to 7	2	0.025	0.05
8	$5/16$	1 to 30	8	0.1	0.1

1) Available only for nominal diameters DN 15 to 150 ($1/2$ to 6") and with the order code for "Sensor option", option CI "Medium temperature measurement".

Nominal diameter		Recommended flow min./max. full scale value (v ~ 0.3/10 m/s) [dm ³ /min]	Factory settings		
[mm]	[in]		Full scale value current output (v ~ 2.5 m/s) [dm ³ /min]	Pulse value (~ 2 pulse/s) [dm ³]	Low flow cut off (v ~ 0.04 m/s) [dm ³ /min]
15	½	4 to 100	25	0.2	0.5
25 ¹⁾	1	9 to 300	75	0.5	1
40	1 ½	25 to 700	200	1.5	3
50	2	35 to 1 100	300	2.5	5
65	–	60 to 2 000	500	5	8
80	3	90 to 3 000	750	5	12
100	4	145 to 4 700	1200	10	20
125	5	220 to 7 500	1850	15	30

1) The values apply for the product version: 5HxB26

Flow characteristic values in SI units: DN 150 (6")

Nominal diameter		Recommended flow min./max. full scale value (v ~ 0.3/10 m/s) [m ³ /h]	Factory settings		
[mm]	[in]		Full scale value current output (v ~ 2.5 m/s) [m ³ /h]	Pulse value (~ 2 pulse/s) [m ³]	Low flow cut off (v ~ 0.04 m/s) [m ³ /h]
150	6	20 to 600	150	0.03	2.5

Flow characteristic values in US units: ½" - 6" (DN 2 - 150)

Nominal diameter		Recommended flow min./max. full scale value (v ~ 0.3/10 m/s) [gal/min]	Full scale value current output (v ~ 2.5 m/s) [gal/min]	Pulse value (~ 2 pulse/s) [gal]	Low flow cut off (v ~ 0.04 m/s) [gal/min]
[in]	[mm]				
½ ₁₂	2	0.015 to 0.5	0.1	0.001	0.002
½ ₃₂	4	0.07 to 2	0.5	0.005	0.008
¾ ₁₆	8	0.25 to 8	2	0.02	0.025
½	15	1 to 27	6	0.05	0.1
1 ¹⁾	25	2.5 to 80	18	0.2	0.25
1 ½	40	7 to 190	50	0.5	0.75
2	50	10 to 300	75	0.5	1.25
3	80	24 to 800	200	2	2.5
4	100	40 to 1 250	300	2	4
5	125	60 to 1 950	450	5	7
6	150	90 to 2 650	600	5	12

1) The values apply for the product version: 5HxB26

Recommended measuring range

 Flow limit →  74

 For custody transfer, the applicable approval determines the permitted measuring range, the pulse value and the low flow cut off.

Operable flow range

Over 1000 : 1

 For custody transfer, the operable flow range is 100 : 1 to 630 : 1, depending on the nominal diameter. Further details are specified by the applicable approval.

Input signal**Output and input variants**

→  14

External measured values

To increase the measurement accuracy of certain measured variables or to calculate the mass flow, the automation system can continuously write different measured values to the measuring instrument:

- Medium temperature enables temperature-compensated conductivity measurement (e.g. iTEMP)
- Reference density for calculating the mass flow

 Various pressure and temperature measuring devices can be ordered from Endress+Hauser: see "Accessories" section →  139

It is recommended to read in external measured values to calculate the corrected volume flow.

HART protocol

The measured values are written from the automation system to the measuring device via the HART protocol. The pressure transmitter must support the following protocol-specific functions:

- HART protocol
- Burst mode

Current input

The measured values are written from the automation system to the measuring device via the current input →  12.

Digital communication

The measured values can be written by the automation system via:

- FOUNDATION Fieldbus
- PROFIBUS DP
- PROFIBUS PA
- Modbus RS485
- Modbus TCP over Ethernet-APL
- Ethernet/IP
- PROFINET
- PROFINET over Ethernet-APL

Current input 0/4 to 20 mA

Current input	0/4 to 20 mA (active/passive)
Current span	<ul style="list-style-type: none"> ▪ 4 to 20 mA (active) ▪ 0/4 to 20 mA (passive)
Resolution	1 µA
Voltage drop	Typically: 0.6 to 2 V for 3.6 to 22 mA (passive)
Maximum input voltage	≤ 30 V (passive)
Open-circuit voltage	≤ 28.8 V (active)
Possible input variables	<ul style="list-style-type: none"> ▪ Temperature ▪ Density

Status input

Maximum input values	<ul style="list-style-type: none"> ▪ DC -3 to 30 V ▪ If status input is active (ON): $R_i > 3 \text{ k}\Omega$
Response time	Configurable: 5 to 200 ms
Input signal level	<ul style="list-style-type: none"> ▪ Low signal: DC -3 to +5 V ▪ High signal: DC 12 to 30 V
Assignable functions	<ul style="list-style-type: none"> ▪ Off ▪ Reset the individual totalizers separately ▪ Reset all totalizers ▪ Flow override

Output

Output and input variants

Depending on the option selected for output/input 1, different options are available for the other outputs and inputs. Only one option can be selected for each output/input 1 to 4. The following tables must be read vertically (↓).

Example: If the option BA "4–20 mA HART" was selected for output/input 1, one of the options A, B, D, E, F, H, I or J is available for output 2 and one of the options A, B, D, E, F, H, I or J is available for output 3 and 4.

Output/input 1 and options for output/input 2

 Options for output/input 3 and 4 →  15

Order code for "Output; input 1" (020) →	Possible options												
Current output 4 to 20 mA HART	BA												
Current output 4 to 20 mA HART Ex i passive	↓	CA											
Current output 4 to 20 mA HART Ex i active		↓	CC										
FOUNDATION Fieldbus			↓	SA									
FOUNDATION Fieldbus Ex i				↓	TA								
PROFIBUS DP					↓	LA							
PROFIBUS PA						↓	GA						
PROFIBUS PA Ex i							↓	HA					
Modbus RS485								↓	MA				
EtherNet/IP 2-port switch integrated									↓	NA			
PROFINET 2-port switch integrated										↓	RA		
PROFINET over Ethernet-APL											↓	RB	
PROFINET over Ethernet-APL Ex i												↓	RC
Order code for "Output; input 2" (021) →	↓	↓	↓	↓	↓	↓	↓	↓	↓	↓	↓	↓	↓
Not used	A	A	A	A	A	A	A	A	A	A	A	A	A
Current output 4 to 20 mA	B			B		B	B		B	B	B	B	
Current output 4 to 20 mA Ex i passive		C	C		C			C					C
User-configurable input/output ¹⁾	D			D		D	D		D	D	D	D	
Pulse/frequency/switch output	E			E		E	E		E	E	E	E	
Double pulse output ²⁾	F								F				
Pulse/frequency/switch output Ex i passive		G	G		G			G					G
Relay output	H			H		H	H		H	H	H	H	
Current input 0/4 to 20 mA	I			I		I	I		I	I	I	I	
Status input	J			J		J	J		J	J	J	J	

1) A specific input or output can be assigned →  21 to a user-configurable input/output.

2) If double pulse output (F) is selected for output/input 2 (021), only the double pulse output (F) option is available for selection for output/input 3 (022).

Output/input 1 and options for output/input 3 and 4

 Options for output/input 2 →  14

Order code for "Output; input 1" (020) →	Possible options												
Current output 4 to 20 mA HART	BA												
Current output 4 to 20 mA HART Ex i passive	↓	CA											
Current output 4 to 20 mA HART Ex i active		↓	CC										
FOUNDATION Fieldbus			↓	SA									
FOUNDATION Fieldbus Ex i				↓	TA								
PROFIBUS DP					↓	LA							
PROFIBUS PA						↓	GA						
PROFIBUS PA Ex i							↓	HA					
Modbus RS485								↓	MA				
EtherNet/IP 2-port switch integrated									↓	NA			
PROFINET 2-port switch integrated										↓	RA		
PROFINET over Ethernet-APL/SPE, 10 Mbit/s, 2-wire											↓	RB	
PROFINET over Ethernet-APL Ex i, 10 Mbit/s, 2-wire												↓	RC
Order code for "Output; input 3" (022), "Output; input 4" (023) ¹⁾ →	↓	↓	↓	↓	↓	↓	↓	↓	↓	↓	↓	↓	↓
Not used	A	A	A	A	A	A	A	A	A	A	A	A	A
Current output 4 to 20 mA	B						B			B	B	B	B
Current output 4 to 20 mA Ex i passive ²⁾		C	C										
User-configurable input/output	D						D			D	D	D	D
Pulse/frequency/switch output	E						E			E	E	E	E
Double pulse output (slave) ³⁾	F									F			
Pulse/frequency/switch output Ex i passive ⁴⁾		G	G										
Relay output	H						H			H	H	H	H
Current input 0/4 to 20 mA	I						I			I	I	I	I
Status input	J						J			J	J	J	J

- 1) The order code for "Output; input 4" (023) is only available for the Proline 500-digital transmitter, order code for "Integrated ISEM electronics", option A.
- 2) The current output 4 to 20 mA Ex i passive (C) option is not available for input/output 4.
- 3) The double pulse output (F) option is not available for input/output 4.
- 4) The pulse/frequency/switch output Ex i passive (G) option is not available for input/output 4.

Output signal

Current output 4 to 20 mA HART

Order code	"Output; input 1" (20): Option BA: current output 4 to 20 mA HART
Signal mode	Can be set to: <ul style="list-style-type: none"> ■ Active ■ Passive
Current range	Can be set to: <ul style="list-style-type: none"> ■ 4 to 20 mA NAMUR ■ 4 to 20 mA US ■ 4 to 20 mA ■ 0 to 20 mA (only if the signal mode is active) ■ Fixed current
Open-circuit voltage	DC 28.8 V (active)
Maximum input voltage	DC 30 V (passive)
Load	250 to 700 Ω
Resolution	0.38 μ A
Damping	Configurable: 0 to 999.9 s
Assignable measured variables	<ul style="list-style-type: none"> ■ Volume flow ■ Mass flow ■ Corrected volume flow ■ Flow velocity ■ Conductivity ■ Corrected conductivity ■ Temperature ■ Electronics temperature

Current output 4 to 20 mA HART Ex i

Order code	"Output; input 1" (20) choose from: <ul style="list-style-type: none"> ■ Option CA: current output 4 to 20 mA HART Ex i passive ■ Option CC: current output 4 to 20 mA HART Ex i active
Signal mode	Depends on the selected order version.
Current range	Can be set to: <ul style="list-style-type: none"> ■ 4 to 20 mA NAMUR ■ 4 to 20 mA US ■ 4 to 20 mA ■ 0 to 20 mA (only if the signal mode is active) ■ Fixed current
Open-circuit voltage	DC 21.8 V (active)
Maximum input voltage	DC 30 V (passive)
Load	<ul style="list-style-type: none"> ■ 250 to 400 Ω (active) ■ 250 to 700 Ω (passive)
Resolution	0.38 μ A
Damping	Configurable: 0 to 999.9 s
Assignable measured variables	<ul style="list-style-type: none"> ■ Volume flow ■ Mass flow ■ Corrected volume flow ■ Flow velocity ■ Conductivity ■ Corrected conductivity ■ Temperature ■ Electronics temperature

FOUNDATION Fieldbus

FOUNDATION Fieldbus	H1, IEC 61158-2, galvanically isolated
Data transfer	31.25 kbit/s
Current consumption	10 mA
Permitted supply voltage	9 to 32 V
Bus connection	With integrated reverse polarity protection

PROFIBUS DP

Signal encoding	NRZ code
Data transfer	9.6 kBaud...12 MBaud
Terminating resistor	Integrated, can be activated via DIP switches

PROFIBUS PA

PROFIBUS PA	In accordance with EN 50170 Volume 2, IEC 61158-2 (MBP), galvanically isolated
Data transmission	31.25 kbit/s
Current consumption	10 mA
Permitted supply voltage	9 to 32 V
Bus connection	With integrated reverse polarity protection

Modbus RS485

Physical interface	RS485 in accordance with EIA/TIA-485 standard
Terminating resistor	Integrated, can be activated via DIP switches

EtherNet/IP

Standards	In accordance with IEEE 802.3
------------------	-------------------------------

PROFINET

Standards	In accordance with IEEE 802.3
------------------	-------------------------------

PROFINET with Ethernet-APL

Device use	<p>Device connection to an APL field switch The device may only be operated according to the following APL port classifications:</p> <ul style="list-style-type: none"> ▪ If used in hazardous areas: SLAA or SLAC ¹⁾ ▪ If used in non-hazardous areas: SLAX <p>Connection values of APL field switch (corresponds to APL port classification SPCC or SPAA, for instance):</p> <ul style="list-style-type: none"> ▪ Maximum input voltage: 15 V_{DC} ▪ Minimum output values: 0.54 W <p>Device connection to an SPE switch</p> <ul style="list-style-type: none"> ▪ In non-hazardous areas, the device can be used with an appropriate SPE switch: The device can be connected to an SPE switch with a maximum voltage of 30 V_{DC} and a minimum output power of 1.85 W connected. ▪ The SPE switch must support the 10BASE-T1L standard and PoDL power classes 10, 11 or 12 and have a function to disable power class detection.
PROFINET	According to IEC 61158 and IEC 61784
Ethernet-APL	According to IEEE 802.3cg, APL port profile specification v1.0, galvanically isolated
Data transmission	10 Mbit/s
Current consumption	<p>Transmitter</p> <ul style="list-style-type: none"> ▪ Max. 400 mA (24 V) ▪ Max. 200 mA (110 V, 50/60 Hz; 230 V, 50/60 Hz)
Permitted supply voltage	9 to 30 V
Network connection	With integrated reverse polarity protection

1) For more information on using the device in the hazardous area, see the Ex-specific Safety Instructions

Current output 4 to 20 mA

Order code	"Output; input 2" (21), "Output; input 3" (022) or "Output; input 4" (023): Option B: current output 4 to 20 mA
Signal mode	Can be set to: <ul style="list-style-type: none"> ▪ Active ▪ Passive
Current range	Can be set to: <ul style="list-style-type: none"> ▪ 4 to 20 mA NAMUR ▪ 4 to 20 mA US ▪ 4 to 20 mA ▪ 0 to 20 mA (only if the signal mode is active) ▪ Fixed current
Maximum output values	22.5 mA
Open-circuit voltage	DC 28.8 V (active)
Maximum input voltage	DC 30 V (passive)
Load	0 to 700 Ω
Resolution	0.38 μA
Damping	Configurable: 0 to 999.9 s
Assignable measured variables	<ul style="list-style-type: none"> ▪ Volume flow ▪ Mass flow ▪ Corrected volume flow ▪ Flow velocity ▪ Conductivity ▪ Corrected conductivity ▪ Temperature ▪ Electronics temperature

Current output 4 to 20 mA Ex i passive

Order code	"Output; input 2" (21), "Output; input 3" (022): Option C: current output 4 to 20 mA Ex i passive
Signal mode	Passive
Current range	Can be set to: <ul style="list-style-type: none"> ■ 4 to 20 mA NAMUR ■ 4 to 20 mA US ■ 4 to 20 mA ■ Fixed current
Maximum output values	22.5 mA
Maximum input voltage	DC 30 V
Load	0 to 700 Ω
Resolution	0.38 µA
Damping	Configurable: 0 to 999 s
Assignable measured variables	<ul style="list-style-type: none"> ■ Volume flow ■ Mass flow ■ Corrected volume flow ■ Flow velocity ■ Conductivity ■ Corrected conductivity ■ Temperature ■ Electronics temperature

Pulse/frequency/switch output

Function	Can be configured as pulse, frequency or switch output
Version	Open collector Can be set to: <ul style="list-style-type: none"> ■ Active ■ Passive ■ Passive NAMUR  Ex-i, passive
Maximum input values	DC 30 V, 250 mA (passive)
Open-circuit voltage	DC 28.8 V (active)
Voltage drop	For 22.5 mA: ≤ DC 2 V
Pulse output	
Maximum input values	DC 30 V, 250 mA (passive)
Maximum output current	22.5 mA (active)
Open-circuit voltage	DC 28.8 V (active)
Pulse width	Configurable: 0.05 to 2 000 ms
Maximum pulse rate	10 000 Impulse/s
Pulse value	Configurable
Assignable measured variables	<ul style="list-style-type: none"> ■ Volume flow ■ Mass flow ■ Corrected volume flow
Frequency output	
Maximum input values	DC 30 V, 250 mA (passive)
Maximum output current	22.5 mA (active)
Open-circuit voltage	DC 28.8 V (active)
Output frequency	Configurable: end value frequency 2 to 10 000 Hz ($f_{\max} = 12\,500$ Hz)

Damping	Configurable: 0 to 999.9 s
Pulse/pause ratio	1:1
Assignable measured variables	<ul style="list-style-type: none"> ▪ Volume flow ▪ Mass flow ▪ Corrected volume flow ▪ Flow velocity ▪ Conductivity ▪ Corrected conductivity ▪ Temperature ▪ Electronics temperature
Switch output	
Maximum input values	DC 30 V, 250 mA (passive)
Open-circuit voltage	DC 28.8 V (active)
Switching behavior	Binary, conductive or non-conductive
Switching delay	Configurable: 0 to 100 s
Number of switching cycles	Unlimited
Assignable functions	<ul style="list-style-type: none"> ▪ Disable ▪ On ▪ Diagnostic behavior ▪ Limit value: <ul style="list-style-type: none"> ▪ Disable ▪ Volume flow ▪ Mass flow ▪ Corrected volume flow ▪ Flow velocity ▪ Conductivity ▪ Corrected conductivity ▪ Totalizer 1-3 ▪ Temperature ▪ Electronics temperature ▪ Flow direction monitoring ▪ Status <ul style="list-style-type: none"> ▪ Empty pipe detection ▪ Buildup index ▪ HBSI limit value exceeded ▪ Low flow cut off

Double pulse output

Function	Double pulse
Version	Open collector Can be set to: <ul style="list-style-type: none"> ▪ Active ▪ Passive ▪ Passive NAMUR
Maximum input values	DC 30 V, 250 mA (passive)
Open-circuit voltage	DC 28.8 V (active)
Voltage drop	For 22.5 mA: ≤ DC 2 V
Output frequency	Configurable: 0 to 1000 Hz
Damping	Configurable: 0 to 999 s

Pulse/pause ratio	1:1
Assignable measured variables	<ul style="list-style-type: none"> ▪ Volume flow ▪ Mass flow ▪ Corrected volume flow ▪ Flow velocity ▪ Conductivity ▪ Corrected conductivity ▪ Temperature ▪ Electronics temperature

Relay output

Function	Switch output
Version	Relay output, galvanically isolated
Switching behavior	Can be set to: <ul style="list-style-type: none"> ▪ NO (normally open), factory setting ▪ NC (normally closed)
Maximum switching capacity (passive)	<ul style="list-style-type: none"> ▪ DC 30 V, 0.1 A ▪ AC 30 V, 0.5 A
Assignable functions	<ul style="list-style-type: none"> ▪ Disable ▪ On ▪ Diagnostic behavior ▪ Limit value: <ul style="list-style-type: none"> ▪ Disable ▪ Volume flow ▪ Mass flow ▪ Corrected volume flow ▪ Flow velocity ▪ Conductivity ▪ Corrected conductivity ▪ Totalizer 1-3 ▪ Temperature ▪ Electronics temperature ▪ Flow direction monitoring ▪ Status <ul style="list-style-type: none"> ▪ Empty pipe detection ▪ Buildup index ▪ HBSI limit value exceeded ▪ Low flow cut off

User-configurable input/output

One specific input or output is assigned to a user-configurable input/output (configurable I/O) during device commissioning.

The following inputs and outputs are available for assignment:

- Choice of current output: 4 to 20 mA (active), 0/4 to 20 mA (passive)
- Pulse/frequency/switch output
- Choice of current input: 4 to 20 mA (active), 0/4 to 20 mA (passive)
- Status input

The technical values correspond to those of the inputs and outputs described in this section.

Signal on alarm

Depending on the interface, failure information is displayed as follows:

HART current output

Device diagnostics	Device condition can be read out via HART Command 48
---------------------------	--

PROFIBUS PA

Status and alarm messages	Diagnostics in accordance with PROFIBUS PA Profile 3.02
Failure current FDE (Fault Disconnection Electronic)	0 mA

PROFIBUS DP

Status and alarm messages	Diagnostics in accordance with PROFIBUS PA Profile 3.02
---------------------------	---

EtherNet/IP

Device diagnostics	Device condition can be read out in Input Assembly
--------------------	--

PROFINET

Device diagnostics	According to "Application Layer protocol for decentralized periphery", Version 2.3
--------------------	--

PROFINET with Ethernet-APL

Device diagnostics	Diagnostics according to PROFINET PA Profile 4
--------------------	--

FOUNDATION Fieldbus

Status and alarm messages	Diagnostics in accordance with FF-891
Failure current FDE (Fault Disconnection Electronic)	0 mA

Modbus RS485

Failure mode	Choose from: <ul style="list-style-type: none"> ▪ NaN value instead of current value ▪ Last valid value
--------------	---

Modbus TCP-APL

Failure mode	Choose from: <ul style="list-style-type: none"> ▪ NaN value instead of current value ▪ Last valid value
--------------	---

Current output 0/4 to 20 mA*4 to 20 mA*

Failure mode	Choose from: <ul style="list-style-type: none"> ▪ 4 to 20 mA in accordance with NAMUR recommendation NE 43 ▪ 4 to 20 mA in accordance with US ▪ Min. value: 3.59 mA ▪ Max. value: 22.5 mA ▪ Definable value between: 3.59 to 22.5 mA ▪ Actual value ▪ Last valid value
--------------	---

0 to 20 mA

Failure mode	Choose from: <ul style="list-style-type: none"> ▪ Maximum alarm: 22 mA ▪ Definable value between: 0 to 20.5 mA
---------------------	--

Pulse/frequency/switch output

Pulse output	
Fault mode	Choose from: <ul style="list-style-type: none"> ▪ Actual value ▪ No pulses
Frequency output	
Fault mode	Choose from: <ul style="list-style-type: none"> ▪ Actual value ▪ 0 Hz ▪ Definable value between: 2 to 12 500 Hz
Switch output	
Fault mode	Choose from: <ul style="list-style-type: none"> ▪ Current status ▪ Open ▪ Closed

Relay output

Failure mode	Choose from: <ul style="list-style-type: none"> ▪ Current status ▪ Open ▪ Closed
---------------------	---

Local display

Plain text display	With information on cause and remedial measures
Backlight	Red lighting indicates a device error.

 Status signal as per NAMUR recommendation NE 107

Interface/protocol

- Via digital communication:
 - HART protocol
 - FOUNDATION Fieldbus
 - PROFIBUS PA
 - PROFIBUS DP
 - Modbus RS485
 - Modbus TCP with Ethernet-APL
 - EtherNet/IP
 - PROFINET
 - PROFINET with Ethernet-APL
- Via service interface
 - CDI-RJ45 service interface
 - WLAN interface

Plain text display	With information on cause and remedial measures
---------------------------	---

 Additional information on remote operation →  116

Web browser

Plain text display	With information on cause and remedial measures
--------------------	---

Light emitting diodes (LED)

Status information	<p>Status indicated by various light emitting diodes</p> <p>The following information is displayed depending on the device version:</p> <ul style="list-style-type: none"> ■ Supply voltage active ■ Data transmission active ■ Device alarm/error has occurred ■ EtherNet/IP network available ■ EtherNet/IP connection established ■ PROFINET network available ■ PROFINET connection established ■ PROFINET blinking feature
--------------------	---

Load Output signal → 16

Ex connection data

Safety-related values

Order code "Output; input 1"	Output type	Safety-related values "Output; input 1"	
		26 (+)	27 (-)
Option BA	Current output 4 to 20 mA HART	$U_N = 30 V_{DC}$ $U_M = 250 V_{AC}$	
Option GA	PROFIBUS PA	$U_N = 32 V_{DC}$ $U_M = 250 V_{AC}$	
Option LA	PROFIBUS DP	$U_N = 32 V_{DC}$ $U_M = 250 V_{AC}$	
Option MA	Modbus RS485	$U_N = 30 V_{DC}$ $U_M = 250 V_{AC}$	
Option MB	Modbus TCP with Ethernet-APL	APL port profile SLAX SPE PoDL classes 10, 11, 12 $U_N = 30 V_{DC}$ $U_M = 250 V_{AC}$	
Option SA	FOUNDATION Fieldbus	$U_N = 32 V_{DC}$ $U_M = 250 V_{AC}$	
Option NA	EtherNet/IP	$U_N = 30 V_{DC}$ $U_M = 250 V_{AC}$	
Option RA	PROFINET	$U_N = 30 V_{DC}$ $U_M = 250 V_{AC}$	
Option RB	PROFINET with Ethernet- APL	APL port profile SLAX SPE PoDL classes 10, 11, 12 $U_N = 30 V_{DC}$ $U_M = 250 V_{AC}$	

Order code "Output; input 2"; "Output; input 3" "Output; input 4"	Output type	Safety-related values					
		Output; input 2		Output; input 3		Output; input 4 ¹⁾	
		24 (+)	25 (-)	22 (+)	23 (-)	20 (+)	21 (-)
Option B	Current output 4 to 20 mA	$U_N = 30 V_{DC}$ $U_M = 250 V_{AC}$					
Option D	User-configurable input/ output	$U_N = 30 V_{DC}$ $U_M = 250 V_{AC}$					

Order code "Output; input 2"; "Output; input 3" "Output; input 4"	Output type	Safety-related values					
		Output; input 2		Output; input 3		Output; input 4 ¹⁾	
		24 (+)	25 (-)	22 (+)	23 (-)	20 (+)	21 (-)
Option E	Pulse/frequency/switch output	U _N = 30 V _{DC} U _M = 250 V _{AC}					
Option F	Double pulse output	U _N = 30 V _{DC} U _M = 250 V _{AC}					
Option H	Relay output	U _N = 30 V _{DC} I _N = 100 mA _{DC} /500 mA _{AC} U _M = 250 V _{AC}					
Option I	Current input 4 to 20 mA	U _N = 30 V _{DC} U _M = 250 V _{AC}					
Option J	Status input	U _N = 30 V _{DC} U _M = 250 V _{AC}					

1) The order code "Output; input 4" is only available for the Proline 500 – digital transmitter.

Intrinsically safe values

Order code "Output; input 1"	Output type	Intrinsically safe values "Output; input 1"	
		26 (+)	27 (-)
Option CA	Current output 4 to 20 mA HART Ex i passive	U _i = 30 V I _i = 100 mA P _i = 1.25 W L _i = 0 μH C _i = 6 nF	
Option CC	Current output 4 to 20 mA HART Ex i active	Ex ia ¹⁾ U ₀ = 21.8 V I ₀ = 90 mA P ₀ = 491 mW L ₀ = 4.1 mH (IIC)/15 mH (IIB) C ₀ = 160 nF (IIC)/ 1 160 nF (IIB)	Ex ic ²⁾ U ₀ = 21.8 V I ₀ = 90 mA P ₀ = 491 mW L ₀ = 9 mH (IIC)/39 mH (IIB) C ₀ = 600 nF (IIC)/ 4 000 nF (IIB)
Option HA	PROFIBUS PA Ex i (FISCO Field Device)	Ex ia ¹⁾ U _i = 30 V I _i = 570 mA P _i = 8.5 W L _i = 10 μH C _i = 5 nF	Ex ic ²⁾ U _i = 32 V I _i = 570 mA P _i = 8.5 W L _i = 10 μH C _i = 5 nF
Option TA	FOUNDATION Fieldbus Ex i	Ex ia ¹⁾ U _i = 30 V I _i = 570 mA P _i = 8.5 W L _i = 10 μH C _i = 5 nF	Ex ic ²⁾ U _i = 32 V I _i = 570 mA P _i = 8.5 W L _i = 10 μH C _i = 5 nF
Option RC	PROFINET with Ethernet- APL Ex i	Ex ia ¹⁾ 2-WISE power load APL port profile SLAA	Ex ic ²⁾ 2-WISE power load APL port profile SLAC

1) Only available for Proline 500 transmitter Zone 1; Class I, Division 1.

2) Only available for transmitter Zone 2; Class I, Division 2 and only for Proline 500 – digital transmitter

Order code "Output; input 2"; "Output; input 3"; "Output; input 4"	Output type	Intrinsically safe values or NIFW values					
		Output; input 2		Output; input 3		Output; input 4 ¹⁾	
		24 (+)	25 (-)	22 (+)	23 (-)	20 (+)	21 (-)
Option C	Current output 4 to 20 mA Ex i passive	$U_i = 30\text{ V}$ $I_i = 100\text{ mA}$ $P_i = 1.25\text{ W}$ $L_i = 0$ $C_i = 0$					
Option G	Pulse/frequency/switch output Ex-i passive	$U_i = 30\text{ V}$ $I_i = 100\text{ mA}$ $P_i = 1.25\text{ W}$ $L_i = 0$ $C_i = 0$					

1) The order code "Output; input 4" is only available for the Proline 500 – digital transmitter.

Low flow cut off

The switch points for low flow cut off are user-selectable.

Galvanic isolation

The outputs are galvanically isolated:

- from the power supply
- from one another
- from the potential equalization (PE) terminal

Protocol-specific data

HART

Manufacturer ID	0x11
Device type ID	0x3C
HART protocol revision	7
Device description files (DTM, DD)	Information and files under: www.endress.com
HART load	Min. 250 Ω
System integration	Information on system integration: Operating Instructions → 139. <ul style="list-style-type: none"> ▪ Measured variables via HART protocol ▪ Burst Mode functionality

FOUNDATION Fieldbus

Manufacturer ID	0x452B48 (hex)
Ident number	0x103C (hex)
Device revision	1
DD revision	Information and files under:
CFF revision	<ul style="list-style-type: none"> ▪ www.endress.com ▪ www.fieldcommgroup.org
Interoperability Test Kit (ITK)	Version 6.2.0
ITK Test Campaign Number	Information: <ul style="list-style-type: none"> ▪ www.endress.com ▪ www.fieldcommgroup.org
Link Master capability (LAS)	Yes
Choice of "Link Master" and "Basic Device"	Yes Factory setting: Basic Device
Node address	Factory setting: 247 (0xF7)

Supported functions	The following methods are supported: <ul style="list-style-type: none"> Restart ENP Restart Diagnostic Set to OOS Set to AUTO Read trend data Read event logbook
Virtual Communication Relationships (VCRs)	
Number of VCRs	44
Number of link objects in VFD	50
Permanent entries	1
Client VCRs	0
Server VCRs	10
Source VCRs	43
Sink VCRs	0
Subscriber VCRs	43
Publisher VCRs	43
Device Link Capabilities	
Slot time	4
Min. delay between PDU	8
Max. response delay	16
System integration	Information regarding system integration: Operating Instructions → 139. <ul style="list-style-type: none"> Cyclic data transmission Description of the modules Execution times Methods

PROFIBUS DP

Manufacturer ID	0x11
Ident number	0x1570
Profile version	3.02
Device description files (GSD, DTM, DD)	Information and files under: <ul style="list-style-type: none"> https://www.endress.com/download On the device product page: PRODUCTS → Product Finder → Links https://www.profibus.com
Supported functions	<ul style="list-style-type: none"> Identification & Maintenance Simplest device identification on the part of the control system and nameplate PROFIBUS upload/download Reading and writing parameters is up to ten times faster with PROFIBUS upload/download Condensed status Simplest and self-explanatory diagnostic information by categorizing diagnostic messages that occur
Configuration of the device address	<ul style="list-style-type: none"> DIP switches on the I/O electronics module Via operating tools (e.g. FieldCare)

Compatibility with earlier model	<p>If the device is replaced, the measuring device Promag 500 supports the compatibility of the cyclic data with previous models. It is not necessary to adjust the engineering parameters of the PROFIBUS network with the Promag 500 GSD file.</p> <p>Earlier models:</p> <ul style="list-style-type: none"> ▪ Promag 50 PROFIBUS DP <ul style="list-style-type: none"> ▪ ID No.: 1546 (hex) ▪ Extended GSD file: EH3x1546.gsd ▪ Standard GSD file: EH3_1546.gsd ▪ Promag 53 PROFIBUS DP <ul style="list-style-type: none"> ▪ ID No.: 1526 (hex) ▪ Extended GSD file: EH3x1526.gsd ▪ Standard GSD file: EH3_1526.gsd <p> Description of the function scope of compatibility: Operating Instructions →  139.</p>
System integration	<p>Information regarding system integration: Operating Instructions →  139.</p> <ul style="list-style-type: none"> ▪ Cyclic data transmission ▪ Block model ▪ Description of the modules

PROFIBUS PA

Manufacturer ID	0x11
Ident number	0x156C
Profile version	3.02
Device description files (GSD, DTM, DD)	<p>Information and files under:</p> <ul style="list-style-type: none"> ▪ https://www.endress.com/download On the device product page: PRODUCTS → Product Finder → Links ▪ https://www.profibus.com
Supported functions	<ul style="list-style-type: none"> ▪ Identification & Maintenance Simplest device identification on the part of the control system and nameplate ▪ PROFIBUS upload/download Reading and writing parameters is up to ten times faster with PROFIBUS upload/download ▪ Condensed status Simplest and self-explanatory diagnostic information by categorizing diagnostic messages that occur
Configuration of the device address	<ul style="list-style-type: none"> ▪ DIP switches on the I/O electronics module ▪ Local display ▪ Via operating tools (e.g. FieldCare)
Compatibility with earlier model	<p>If the device is replaced, the measuring device Promag 500 supports the compatibility of the cyclic data with previous models. It is not necessary to adjust the engineering parameters of the PROFIBUS network with the Promag 500 GSD file.</p> <p>Earlier models:</p> <ul style="list-style-type: none"> ▪ Promag 50 PROFIBUS PA <ul style="list-style-type: none"> ▪ ID No.: 1525 (hex) ▪ Extended GSD file: EH3x1525.gsd ▪ Standard GSD file: EH3_1525.gsd ▪ Promag 53 PROFIBUS PA <ul style="list-style-type: none"> ▪ ID No.: 1527 (hex) ▪ Extended GSD file: EH3x1527.gsd ▪ Standard GSD file: EH3_1527.gsd <p> Description of the function scope of compatibility: Operating Instructions →  139.</p>
System integration	<p>Information regarding system integration: Operating Instructions →  139.</p> <ul style="list-style-type: none"> ▪ Cyclic data transmission ▪ Block model ▪ Description of the modules

Modbus RS485

Protocol	Modbus Applications Protocol Specification V1.1
Response times	<ul style="list-style-type: none"> ▪ Direct data access: typically 25 to 50 ms ▪ Auto-scan buffer (data range): typically 3 to 5 ms
Device type	Slave
Slave address range	1 to 247
Broadcast address range	0
Function codes	<ul style="list-style-type: none"> ▪ 03: Read holding register ▪ 04: Read input register ▪ 06: Write single registers ▪ 08: Diagnostics ▪ 16: Write multiple registers ▪ 23: Read/write multiple registers
Broadcast messages	Supported by the following function codes: <ul style="list-style-type: none"> ▪ 06: Write single registers ▪ 16: Write multiple registers ▪ 23: Read/write multiple registers
Supported baud rate	<ul style="list-style-type: none"> ▪ 1 200 BAUD ▪ 2 400 BAUD ▪ 4 800 BAUD ▪ 9 600 BAUD ▪ 19 200 BAUD ▪ 38 400 BAUD ▪ 57 600 BAUD ▪ 115 200 BAUD
Data transmission mode	<ul style="list-style-type: none"> ▪ ASCII ▪ RTU
Data access	Each device parameter can be accessed via Modbus RS485.  For Modbus register information
Compatibility with earlier model	If the device is replaced, the measuring device Promag 500 supports the compatibility of the Modbus registers for the process variables and the diagnostic information with the previous model Promag 53. It is not necessary to change the engineering parameters in the automation system.  Description of the function scope of compatibility: Operating Instructions →  139.
System integration	Information regarding system integration: Operating Instructions →  139. <ul style="list-style-type: none"> ▪ Modbus RS485 information ▪ Function codes ▪ Register information ▪ Response time ▪ Modbus data map

EtherNet/IP

Protocol	<ul style="list-style-type: none"> ▪ The CIP Networks Library Volume 1: Common Industrial Protocol ▪ The CIP Networks Library Volume 2: EtherNet/IP Adaptation of CIP
Communication type	<ul style="list-style-type: none"> ▪ 10Base-T ▪ 100Base-TX
Device profile	Generic device (product type: 0x2B)
Manufacturer ID	0x000049E
Device type ID	0x103C
Baud rates	Automatic ¹⁰ / ₁₀₀ Mbit with half-duplex and full-duplex detection
Polarity	Auto-polarity for automatic correction of crossed TxD and RxD pairs
Supported CIP connections	Max. 3 connections

Explicit connections	Max. 6 connections
I/O connections	Max. 6 connections (scanner)
Configuration options for measuring device	<ul style="list-style-type: none"> ▪ DIP switches on the electronics module for IP addressing ▪ Manufacturer-specific software (FieldCare) ▪ Add-on Profile Level 3 for Rockwell Automation control systems ▪ Web browser ▪ Electronic Data Sheet (EDS) integrated in the measuring device
Configuration of the EtherNet interface	<ul style="list-style-type: none"> ▪ Speed: 10 MBit, 100 MBit, auto (factory setting) ▪ Duplex: half-duplex, full-duplex, auto (factory setting)
Configuration of the device address	<ul style="list-style-type: none"> ▪ DIP switches on the electronics module for IP addressing (last octet) ▪ DHCP ▪ Manufacturer-specific software (FieldCare) ▪ Add-on Profile Level 3 for Rockwell Automation control systems ▪ Web browser ▪ EtherNet/IP tools, e.g. RSLinx (Rockwell Automation)
Device Level Ring (DLR)	Yes
System integration	<p>Information regarding system integration: Operating Instructions →  139.</p> <ul style="list-style-type: none"> ▪ Cyclic data transmission ▪ Block model ▪ Input and output groups

PROFINET

Protocol	Application layer protocol for decentral device periphery and distributed automation, Version 2.3
Communication type	100 MBit/s
Conformance Class	Conformance Class B
Netload Class	Netload Class 2 0 Mbps
Baud rates	Automatic 100 Mbit/s with full-duplex detection
Cycle times	From 8 ms
Polarity	Auto-polarity for automatic correction of crossed TxD and RxD pairs
Media Redundancy Protocol (MRP)	Yes
System redundancy support	System redundancy S2 (2 AR with 1 NAP)
Device profile	Application interface identifier 0xF600 Generic device
Manufacturer ID	0x11
Device type ID	0x843C
Device description files (GSD, DTM, DD)	<p>Information and files under:</p> <ul style="list-style-type: none"> ▪ www.endress.com On the product page for the device: Documents/Software → Device drivers ▪ www.profibus.com
Supported connections	<ul style="list-style-type: none"> ▪ 2 x AR (IO Controller AR) ▪ 1 x AR (IO-Supervisor Device AR connection allowed) ▪ 1 x Input CR (Communication Relation) ▪ 1 x Output CR (Communication Relation) ▪ 1 x Alarm CR (Communication Relation)
Configuration options for measuring device	<ul style="list-style-type: none"> ▪ DIP switches on the electronics module, for device name assignment (last part) ▪ Asset management software (FieldCare, DeviceCare, Field Xpert) ▪ Integrated Web server via Web browser and IP address ▪ Device master file (GSD), can be read out via the integrated Web server of the measuring device. ▪ Onsite operation

Configuration of the device name	<ul style="list-style-type: none"> ▪ DIP switches on the electronics module, for device name assignment (last part) ▪ DCP protocol ▪ Asset management software (FieldCare, DeviceCare, Field Xpert) ▪ Integrated Web server
Supported functions	<ul style="list-style-type: none"> ▪ Identification & Maintenance, simple device identifier via: <ul style="list-style-type: none"> ▪ Control system ▪ Nameplate ▪ Measured value status The process variables are communicated with a measured value status ▪ Blinking feature via the local display for simple device identification and assignment ▪ Device operation via asset management software (e.g. FieldCare, DeviceCare, SIMATIC PDM)
System integration	<p>Information regarding system integration: Operating Instructions → 139.</p> <ul style="list-style-type: none"> ▪ Cyclic data transmission ▪ Overview and description of the modules ▪ Status coding ▪ Startup configuration ▪ Factory setting

PROFINET with Ethernet-APL

Protocol	Application layer protocol for decentral device periphery and distributed automation, Version 2.43
Communication type	Ethernet Advanced Physical Layer 10BASE-T1L
Conformance Class	Conformance Class B (PA)
Netload Class	PROFINET Netload Robustness Class 2 10 Mbit/s
Baud rates	10 Mbit/s Full-duplex
Cycle times	64 ms
Polarity	Automatic correction of crossed "APL signal +" and "APL signal -" signal lines
Media Redundancy Protocol (MRP)	Not possible (point-to-point connection to APL field switch)
System redundancy support	System redundancy S2 (2 AR with 1 NAP)
Device profile	PROFINET PA profile 4 (Application interface identifier API: 0x9700)
Manufacturer ID	17
Device type ID	0xA43C
Device description files (GSD, DTM, FDI)	<p>Information and files available at:</p> <ul style="list-style-type: none"> ▪ www.endress.com → Downloads section ▪ www.profibus.com
Supported connections	<ul style="list-style-type: none"> ▪ 2x AR (IO Controller AR) ▪ 2x AR (IO Supervisor Device AR connection allowed)
Configuration options for measuring device	<ul style="list-style-type: none"> ▪ DIP switches on the electronics module, for device name assignment (last part) ▪ Asset management software (FieldCare, DeviceCare, Field Xpert) ▪ Integrated Web server via Web browser and IP address ▪ Device master file (GSD), can be read out via the integrated Web server of the measuring device. ▪ Onsite operation
Configuration of the device name	<ul style="list-style-type: none"> ▪ DIP switches on the electronics module, for device name assignment (last part) ▪ DCP protocol ▪ Asset management software (FieldCare, DeviceCare, Field Xpert) ▪ Integrated Web server

Supported functions	<ul style="list-style-type: none"> ▪ Identification & Maintenance, simple device identifier via: <ul style="list-style-type: none"> ▪ Control system ▪ Nameplate ▪ Measured value status The process variables are communicated with a measured value status ▪ Blinking feature via the local display for simple device identification and assignment ▪ Device operation via asset management software (e.g. FieldCare, DeviceCare, SIMATIC PDM with FDI package)
System integration	<p>Information regarding system integration: Operating Instructions →  139.</p> <ul style="list-style-type: none"> ▪ Cyclic data transmission ▪ Overview and description of the modules ▪ Status coding ▪ Factory setting

Power supply

Terminal assignment

Transmitter: supply voltage, input/outputs

HART

Supply voltage		Input/output 1		Input/output 2		Input/output 3		Input/output 4	
1 (+)	2 (-)	26 (+)	27 (-)	24 (+)	25 (-)	22 (+)	23 (-)	20 (+)	21 (-)
The terminal assignment depends on the specific device version ordered →  14.									

FOUNDATION Fieldbus

Supply voltage		Input/output 1		Input/output 2		Input/output 3		Input/output 4	
1 (+)	2 (-)	26 (A)	27 (B)	24 (+)	25 (-)	22 (+)	23 (-)	20 (+)	21 (-)
The terminal assignment depends on the specific device version ordered →  14.									

PROFIBUS DP

Supply voltage		Input/output 1		Input/output 2		Input/output 3		Input/output 4	
1 (+)	2 (-)	26 (B)	27 (A)	24 (+)	25 (-)	22 (+)	23 (-)	20 (+)	21 (-)
The terminal assignment depends on the specific device version ordered →  14.									

PROFIBUS PA

Supply voltage		Input/output 1		Input/output 2		Input/output 3		Input/output 4	
1 (+)	2 (-)	26 (B)	27 (A)	24 (+)	25 (-)	22 (+)	23 (-)	20 (+)	21 (-)
The terminal assignment depends on the specific device version ordered →  14.									

Modbus RS485

Supply voltage		Input/output 1		Input/output 2		Input/output 3		Input/output 4	
1 (+)	2 (-)	26 (B)	27 (A)	24 (+)	25 (-)	22 (+)	23 (-)	20 (+)	21 (-)
The terminal assignment depends on the specific device version ordered →  14.									

Modbus TCP with Ethernet-APL

Supply voltage		Input/output 1		Input/output 2		Input/output 3		Input/output 4	
1 (+)	2 (-)	26 (B)	27 (A)	24 (+)	25 (-)	22 (+)	23 (-)	20 (+)	21 (-)
The terminal assignment depends on the specific device version ordered → 14.									

EtherNet/IP

Supply voltage		Input/output 1		Input/output 2		Input/output 3		Input/output 4	
1 (+)	2 (-)	EtherNet/IP (RJ45 connector)		24 (+)	25 (-)	22 (+)	23 (-)	20 (+)	21 (-)
The terminal assignment depends on the specific device version ordered → 14.									

PROFINET

Supply voltage		Input/output 1		Input/output 2		Input/output 3		Input/output 4	
1 (+)	2 (-)	PROFINET (RJ45 connector)		24 (+)	25 (-)	22 (+)	23 (-)	20 (+)	21 (-)
The terminal assignment depends on the specific device version ordered → 14.									

PROFINET with Ethernet-APL

Supply voltage		Input/output 1		Input/output 2		Input/output 3		Input/output 4	
1 (+)	2 (-)	26 (+)	27 (-)	24 (+)	25 (-)	22 (+)	23 (-)	20 (+)	21 (-)
The terminal assignment depends on the specific device version ordered → 14.									

Transmitter and sensor connection housing: connecting cable

The sensor and transmitter, which are mounted in separate locations, are interconnected by a connecting cable. The cable is connected via the sensor connection housing and the transmitter housing.

Terminal assignment and connection of the connecting cable:

- Proline 500 – digital → 37
- Proline 500 → 38

Available device plugs

 Device plugs may not be used in hazardous areas!

Device plugs for fieldbus systems:

Order code for "Input; output 1"

- Option **SA** "FOUNDATION Fieldbus" → 33
- Option **GA** "PROFIBUS PA" → 34
- Option **NA** "EtherNet/IP" → 34
- Option **RA** "PROFINET" → 34
- Option **RB** "PROFINET with Ethernet-APL" → 34

Device plug for connecting to the service interface:

Order code for "Accessory mounted"

Option **NB**, RJ45 M12 adapter (service interface) → 36

Order code for "Input; output 1", option SA "FOUNDATION Fieldbus"

Order code for "Electrical connection"	Cable entry/connection → 38	
	2	3
M, 3, 4, 5	7/8" connector	-

Order code for "Input; output 1", option GA "PROFIBUS PA"

Order code for "Electrical connection"	Cable entry/connection → 38	
	2	3
L, N, P, U	Connector M12 × 1	-

Order code for "Input; output 1", option NA "EtherNet/IP"

Order code for "Electrical connection"	Cable entry/connection → 38	
	2	3
L, N, P, U	Connector M12 × 1	-
R ^{1) 2)} , S ^{1) 2)} , T ^{1) 2)} , V ^{1) 2)}	Connector M12 × 1	Connector M12 × 1

- 1) Cannot be combined with an external WLAN antenna (order code for "Enclosed accessories", option P8) of an RJ45 M12 adapter for the service interface (order code for "Accessories mounted", option NB) or of the remote display and operating module DKX001
- 2) Suitable for integrating the device in a ring topology.

Order code for "Input; output 1", option RA "PROFINET"

Order code for "Electrical connection"	Cable entry/connection → 38	
	2	3
L, N, P, U	Connector M12 × 1	-
R ^{1) 2)} , S ^{1) 2)} , T ^{1) 2)} , V ^{1) 2)}	Connector M12 × 1	Connector M12 × 1

- 1) Cannot be combined with an external WLAN antenna (order code for "Enclosed accessories", option P8) of an RJ45 M12 adapter for the service interface (order code for "Accessories mounted", option NB) or of the remote display and operating module DKX001.
- 2) Suitable for integrating the device in a ring topology.

Order code for "Input; output 1", option RB "PROFINET with Ethernet-APL"

Order code "Electrical connection"	Cable entry/connection → 38	
	2	3
L, N, P, U	M12 plug × 1	-

Order code for "Accessory mounted", option NB "Adapter RJ45 M12 (service interface)"

Order code "Accessory mounted"	Cable entry/coupling → 38	
	Cable entry 2	Cable entry 3
NB	Plug M12 × 1	-

Pin assignment, device plug**FOUNDATION Fieldbus**

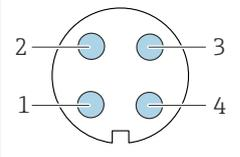
	Pin	Assignment	Coding	Plug/socket
	1	+	Signal +	A
2	-	Signal -		
3		Grounding		
4		Not assigned		

PROFIBUS PA

	Pin	Assignment		Coding	Plug/socket
	1	+	PROFIBUS PA +	A	Plug
	2		Grounding		
	3	-	PROFIBUS PA -		
	4		Not assigned		

- i** Recommended plug:
- Binder, series 713, part no. 99 1430 814 04
 - Phoenix, part no. 1413934 SACC-FS-4QO SH PBPA SCO

PROFINET

	Pin	Assignment		Coding	Plug/socket
	1	+	TD +		
	2	+	RD +		
	3	-	TD -		
	4	-	RD -		
	Coding		Plug/socket		
D		Socket			

- i** Recommended plug:
- Binder, series 825, part no. 99 3729 810 04
 - Phoenix, part no. 1543223 SACC-M12MSD-4Q

PROFINET with Ethernet-APL

	Pin	Assignment	Coding	Plug/socket		
	1	APL signal -			A	Socket
	2	APL signal +				
	3	Cable shield ¹				
	4	Not used				
	Metal plug housing		Cable shield			
¹ If a cable shield is used						

- i** Recommended plug:
- Binder, series 713, part no. 99 1430 814 04
 - Phoenix, part no. 1413934 SACC-FS-4QO SH PBPA SCO

EtherNet/IP

	Pin	Assignment		Coding	Plug/socket
	1	+	Tx		
	2	+	Rx		
	3	-	Tx		
	4	-	Rx		
	Coding		Plug/socket		
D		Socket			

- i** Recommended plug:
- Binder, series 825, part no. 99 3729 810 04
 - Phoenix, part no. 1543223 SACC-M12MSD-4Q

Service interface for

Order code for "Accessories mounted", option **NB**: Adapter RJ45 M12 (service interface)

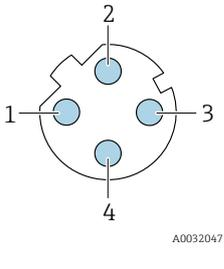
	Pin		Assignment	
	1	+	Tx	
	2	+	Rx	
	3	-	Tx	
	4	-	Rx	
	Coding		Plug/socket	
D		Socket		

- i** Recommended plug:
- Binder, series 825, part no. 99 3729 810 04
 - Phoenix, part no. 1543223 SACC-M12MSD-4Q

Supply voltage	Order code "Power supply"		Terminal voltage		Frequency range
	Option D		DC 24 V	±20%	–
Option E		AC 100 to 240 V	-15...+10%	50/60 Hz, ±4 Hz	
Option I		DC 24 V	±20%	–	
		AC 100 to 240 V	-15...+10%	50/60 Hz, ±4 Hz	

Power consumption	Transmitter		
	Max. 10 W (active power)		
	<table border="1"> <tr> <td>switch-on current</td> <td>Max. 36 A (<5 ms) as per NAMUR Recommendation NE 21</td> </tr> </table>	switch-on current	Max. 36 A (<5 ms) as per NAMUR Recommendation NE 21
switch-on current	Max. 36 A (<5 ms) as per NAMUR Recommendation NE 21		

Current consumption	Transmitter
	<ul style="list-style-type: none"> ▪ Max. 400 mA (24 V) ▪ Max. 200 mA (110 V, 50/60 Hz; 230 V, 50/60 Hz)

Power supply failure	
	<ul style="list-style-type: none"> ▪ Totalizers stop at the last value measured. ▪ Depending on the device version, the configuration is retained in the device memory or in the pluggable data memory (HistoROM DAT). ▪ Error messages (incl. total operated hours) are stored.

Overcurrent protection element	
	<p>The device must be operated with a dedicated circuit breaker, as it does not have an ON/OFF switch of its own.</p> <ul style="list-style-type: none"> ▪ The circuit breaker must be easy to reach and labeled accordingly. ▪ Permitted nominal current of the circuit breaker: 2 A up to maximum 10 A.

Electrical connection

Connection of connecting cable: Proline 500 – digital

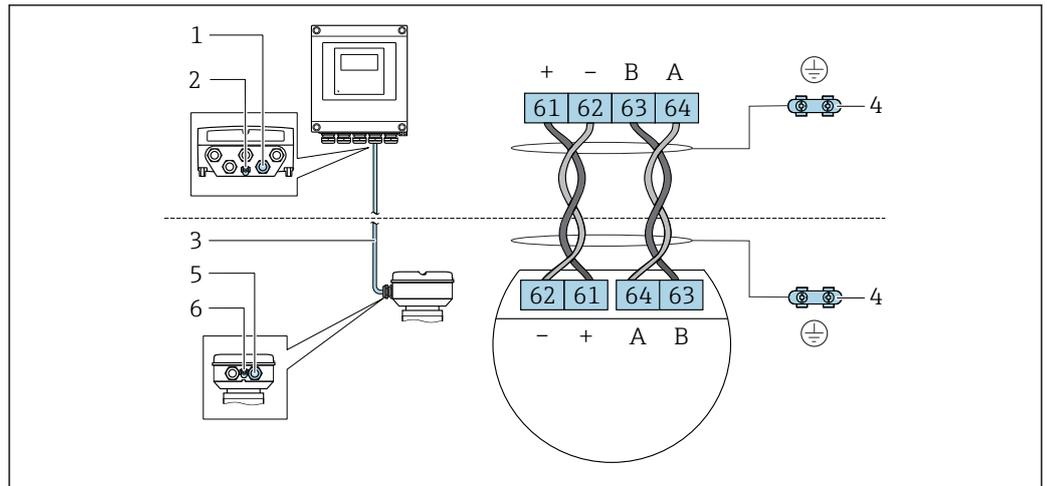

- 1 Cable entry for cable on transmitter housing
- 2 Terminal connection for potential equalization (PE)
- 3 Connecting cable ISEM communication
- 4 Grounding via ground connection; in the version with a device plug, grounding is ensured through the plug itself
- 5 Cable entry for cable or connection of device plug on sensor connection housing
- 6 Terminal connection for potential equalization (PE)

Depending on the device version of the sensor connection housing, the connecting cable is attached via terminals or device plugs.

Sensor connection housing Order code for "Housing"	Connection to sensor connection housing via	Connection to transmitter housing via
Option B: stainless	Terminals	Terminals
Option C: ultra-compact, hygienic, stainless	Device plug	Terminals

Pin assignment, device plug

Device plugs are only available for device version, order code for "Housing":

Option C: ultra-compact, hygienic, stainless

For connection to sensor connection housing.

	Pin	Color ¹⁾	Assignment		Connection to terminal
	1	Brown	+	Supply voltage	
2	White	A	ISEM communication		64
3	Blue	B			63
4	Black	-	Supply voltage		62
5	-		-		-
Coding			Plug/socket		
A			Plug		

1) Cable colors of connecting cable

A connecting cable with a device plug is optionally available.

Connection of the connecting cable: Proline 500

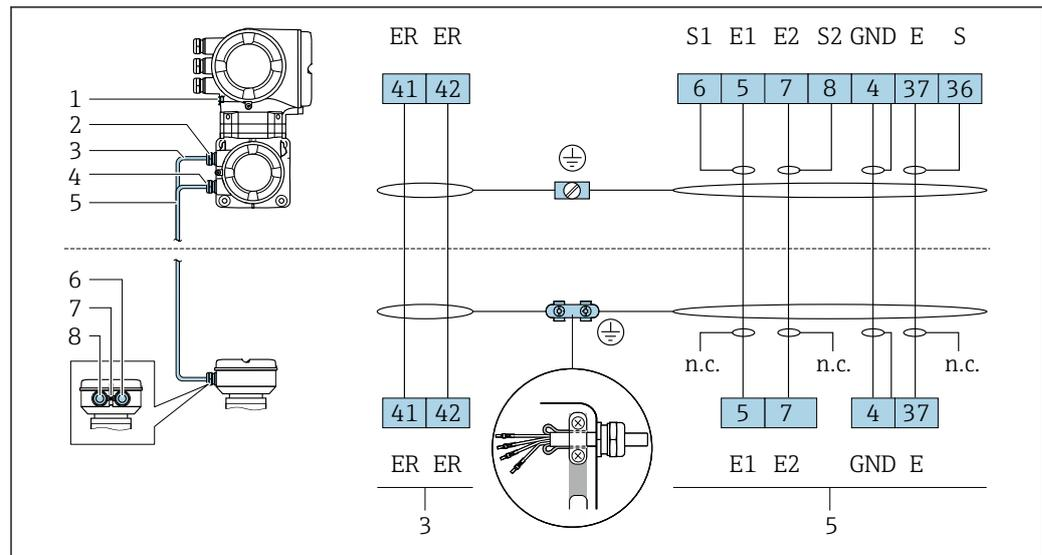

A0029444

- 1 Terminal connection for potential equalization (PE)
- 2 Cable entry for coil current cable on transmitter connection housing
- 3 Coil current cable
- 4 Cable entry for signal cable on transmitter connection housing
- 5 Signal cable
- 6 Cable entry for signal cable on sensor connection housing
- 7 Terminal connection for potential equalization (PE)
- 8 Cable entry for coil current cable on sensor connection housing

Transmitter connection

- i** Terminal assignment → 32
- i** Device plug pin assignment → 34

Transmitter connection: Proline 500 – digital

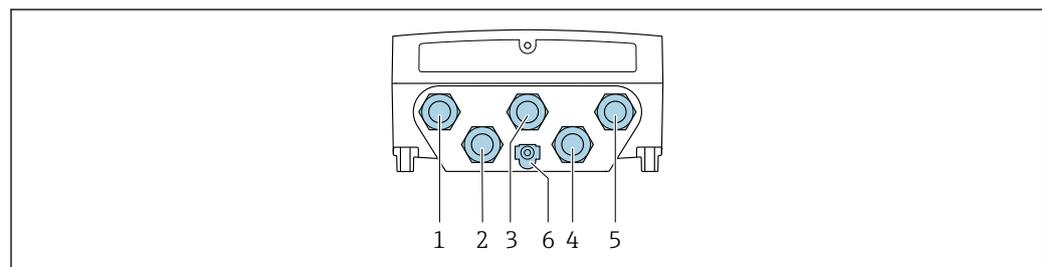

A0028200

- 1 Terminal connection for supply voltage
- 2 Terminal connection for signal transmission, input/output
- 3 Terminal connection for signal transmission, input/output
- 4 Terminal connection for connecting cable between sensor and transmitter
- 5 Terminal connection for signal transmission, input/output or terminal for network connection (DHCP client) via service interface (CDI-RJ45); optional: connection for external WLAN antenna
- 6 Terminal connection for potential equalization (PE)

- i** An adapter for the RJ45 to the M12 plug is optionally available:
Order code for "Accessories", option **NB**: "Adapter RJ45 M12 (service interface)"

The adapter connects the service interface (CDI-RJ45) to an M12 plug mounted in the cable entry. The connection to the service interface can thus be established via an M12 plug without opening the device.

- i** Network connection (DHCP client) via service interface (CDI-RJ45) → 122

Connecting the transmitter: Proline 500

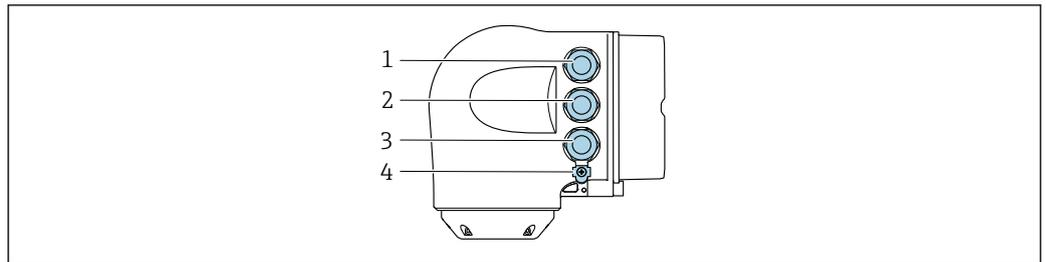

A0026781

- 1 Terminal connection for supply voltage
- 2 Terminal connection for signal transmission, input/output
- 3 Terminal connection for signal transmission, input/output or terminal for network connection (DHCP client) via service interface (CDI-RJ45); optional: connection for external WLAN antenna
- 4 Terminal connection for potential equalization (PE)

i An adapter for the RJ45 to the M12 plug is optionally available:
 Order code for "Accessories", option **NB**: "Adapter RJ45 M12 (service interface)"

The adapter connects the service interface (CDI-RJ45) to an M12 plug mounted in the cable entry. The connection to the service interface can thus be established via an M12 plug without opening the device.

i Network connection (DHCP client) via service interface (CDI-RJ45) → 122

Connecting in a ring topology

Device versions with EtherNet/IP and PROFINET communication protocols can be integrated into a ring topology. The device is integrated via the terminal connection for signal transmission (output 1) and the connection to the service interface (CDI-RJ45).

i Transmitters with an Ex de approval may **not** be connected via the service interface (CDI-RJ45)!
 Order code for "Approval transmitter + sensor", options (Ex de):
 BB, C2, GB, MB, NB

i Integrate the transmitter in a ring topology:

- EtherNet/IP
- PROFINET

Transmitter: Proline 500 – digital

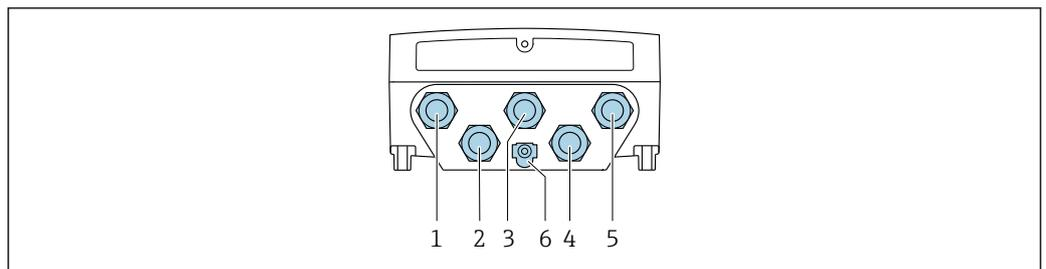

A0028200

- 1 Terminal connection for supply voltage
- 2 Terminal connection for signal transmission, input/output
- 3 Terminal connection for signal transmission: PROFINET or EtherNet/IP (RJ45 plug)
- 4 Terminal connection for connecting cable between sensor and transmitter
- 5 Terminal connection to service interface (CDI-RJ45)
- 6 Terminal connection for potential equalization (PE)

Transmitter: Proline 500

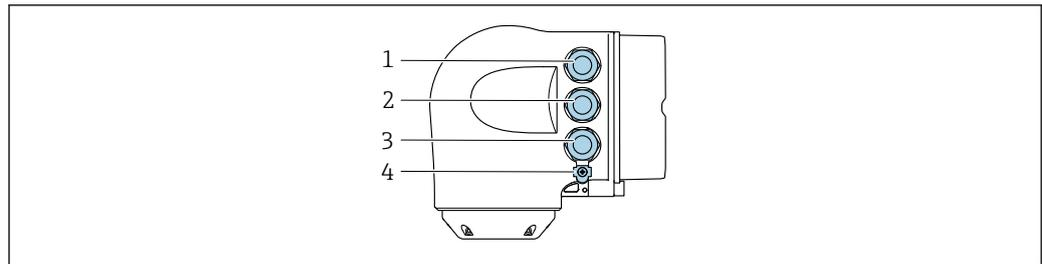

A0026781

- 1 Terminal connection for supply voltage
- 2 Terminal connection for signal transmission: PROFINET or EtherNet/IP (RJ45 plug)
- 3 Terminal connection to service interface (CDI-RJ45)
- 4 Terminal connection for potential equalization (PE)

i If the device has additional inputs/outputs, these are routed in parallel via the cable entry for connection to the service interface.

Connection examples

Current output 4 to 20 mA HART

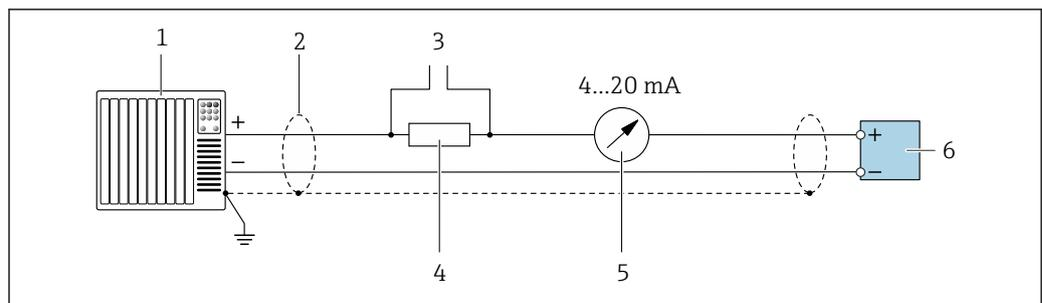

A0029055

2 Connection example for 4 to 20 mA HART current output (active)

- 1 Automation system with current input (e.g. PLC)
- 2 Ground cable shield at one end. The cable shield must be grounded at both ends to comply with EMC requirements; observe cable specifications → 50
- 3 Connection for HART operating devices → 116
- 4 Resistor for HART communication ($\geq 250 \Omega$): observe maximum load → 16
- 5 Analog display unit: observe maximum load → 16
- 6 Transmitter

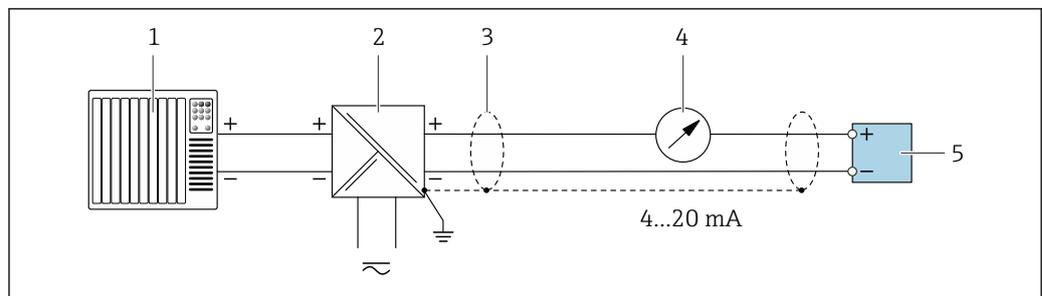

A0028762

3 Connection example for 4 to 20 mA HART current output (passive)

- 1 Automation system with current input (e.g. PLC)
- 2 Power supply
- 3 Ground cable shield at one end. The cable shield must be grounded at both ends to comply with EMC requirements; observe cable specifications → 50
- 4 Analog display unit: observe maximum load → 16
- 5 Transmitter

HART input

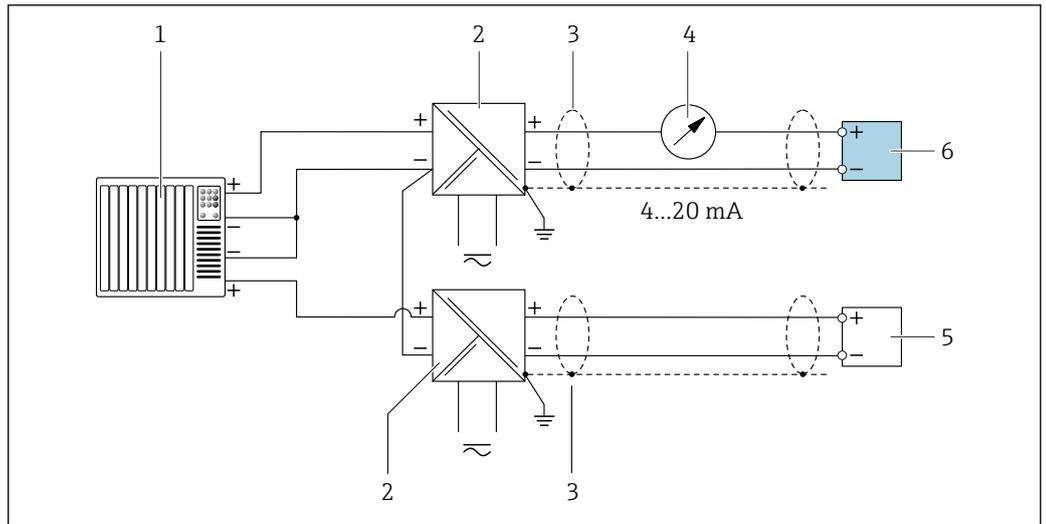

A0028763

4 Connection example for HART input with a common negative (passive)

- 1 Automation system with HART output (e.g. PLC)
- 2 Active barrier for power supply (e.g. RN221N)
- 3 Ground cable shield at one end. The cable shield must be grounded at both ends to comply with EMC requirements; observe cable specifications
- 4 Analog display unit: observe maximum load → 16
- 5 Pressure measuring device (e.g. Cerabar M, Cerabar S): observe requirements
- 6 Transmitter

PROFIBUS PA

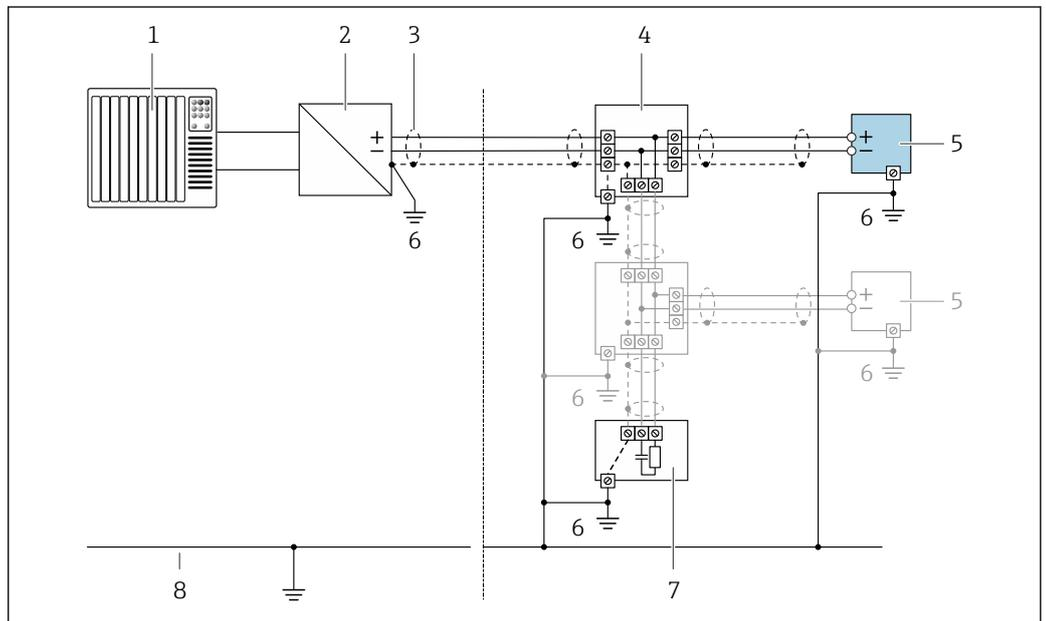

A0028768

5 Connection example for PROFIBUS PA

- 1 Control system (e.g. PLC)
- 2 PROFIBUS PA segment coupler
- 3 Cable shield provided at one end. The cable shield must be grounded at both ends to comply with EMC requirements; observe cable specifications
- 4 T-box
- 5 Measuring device
- 6 Local grounding
- 7 Bus terminator
- 8 Potential matching line

PROFIBUS DP

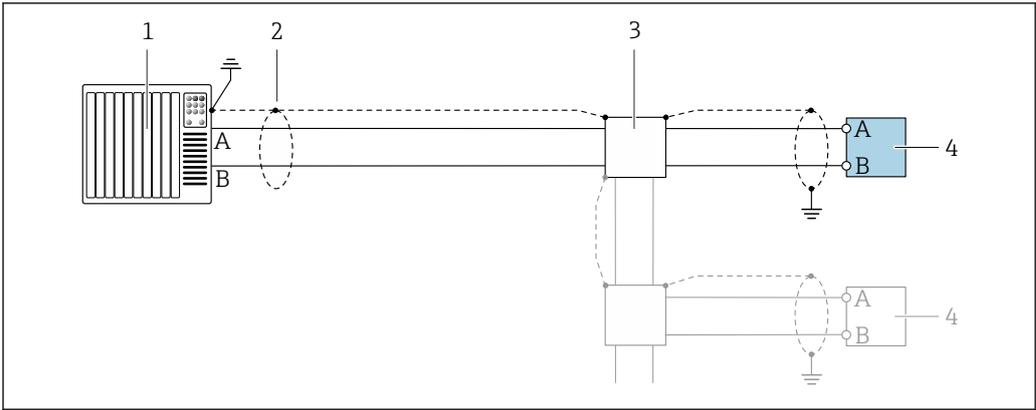

6 Connection example for PROFIBUS DP, non-hazardous area and Zone 2/Div. 2

- 1 Control system (e.g. PLC)
- 2 Cable shield provided at one end. The cable shield must be grounded at both ends to comply with EMC requirements; observe cable specifications
- 3 Distribution box
- 4 Transmitter

i If baud rates > 1.5 MBaud an EMC cable entry must be used and the cable shield must continue as far as the terminal wherever possible.

EtherNet/IP

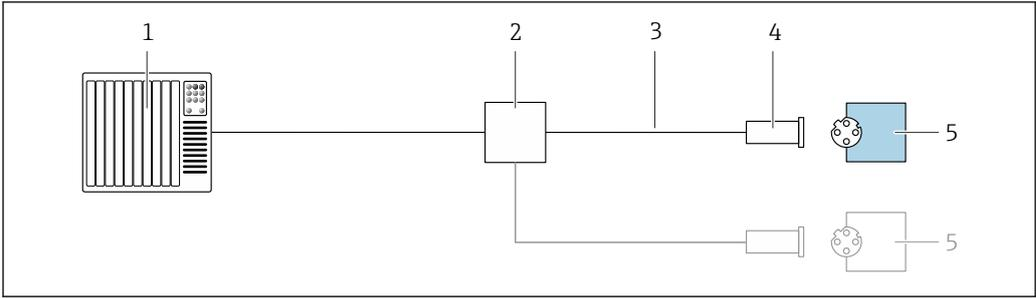

7 Connection example for EtherNet/IP

- 1 Control system (e.g. PLC)
- 2 Ethernet switch
- 3 Observe cable specifications
- 4 Device plug
- 5 Transmitter

EtherNet/IP: DLR (Device Level Ring)

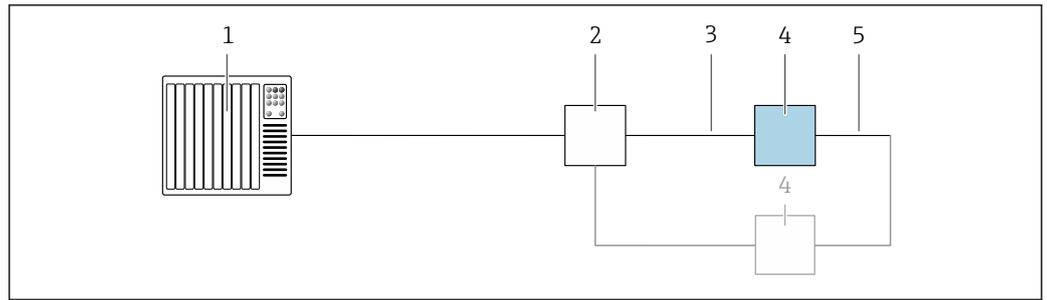

A0027544

- 1 Control system (e.g. PLC)
- 2 Ethernet switch
- 3 Observe cable specifications → 50
- 4 Transmitter
- 5 Connecting cable between the two transmitters

PROFINET

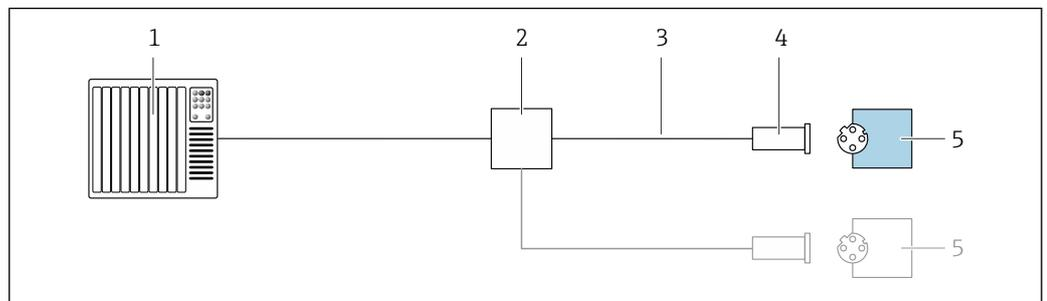

A0028767

8 Connection example for PROFINET

- 1 Control system (e.g. PLC)
- 2 Ethernet switch
- 3 Observe cable specifications
- 4 Device plug
- 5 Transmitter

PROFINET with Ethernet-APL

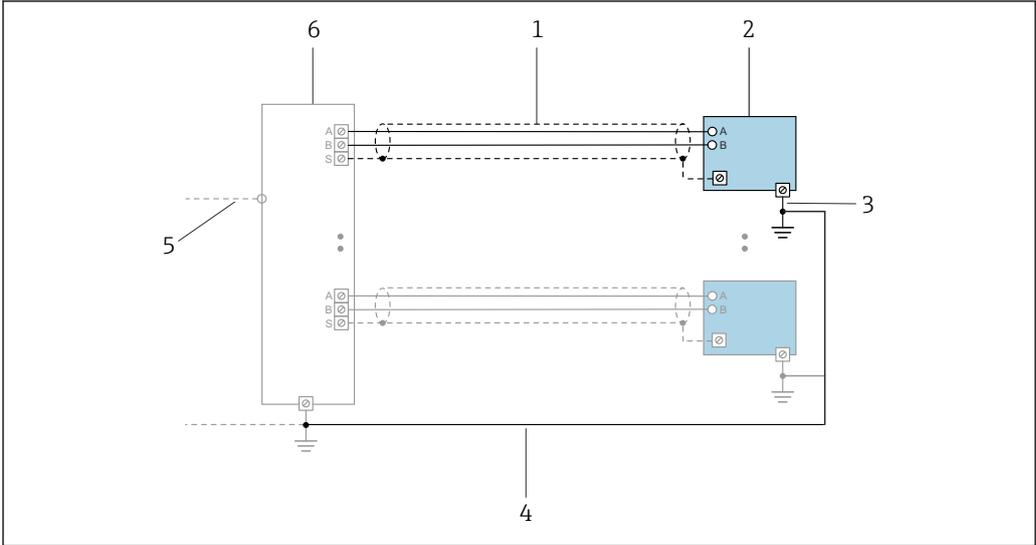

A0047536

9 Connection example for PROFINET with Ethernet-APL

- 1 Cable shield
- 2 Measuring device
- 3 Local grounding
- 4 Potential equalization
- 5 Trunk or TCP
- 6 Field switch

PROFINET: MRP (Media Redundancy Protocol)

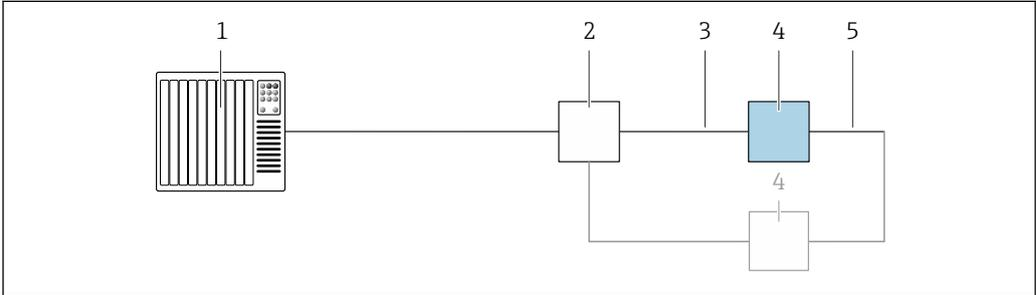

A0027544

- 1 Control system (e.g. PLC)
- 2 Ethernet switch
- 3 Observe cable specifications → 50
- 4 Transmitter
- 5 Connecting cable between the two transmitters

PROFINET: system redundancy S2

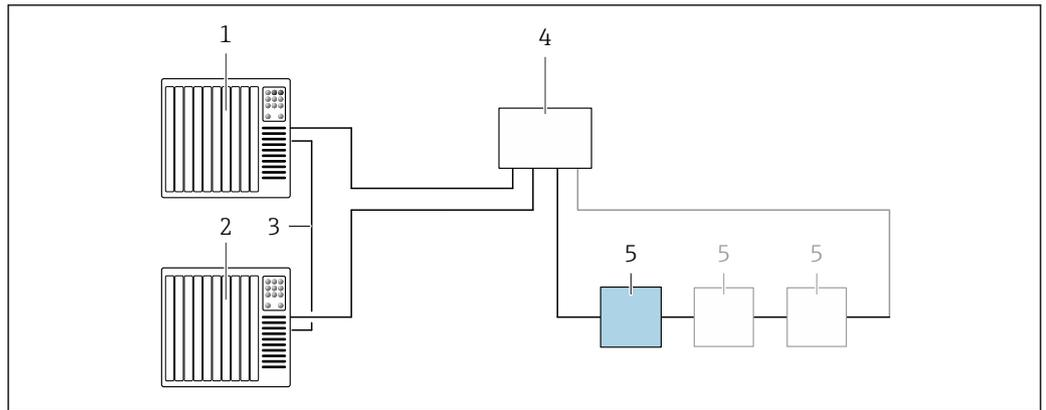

A0039553

10 Connection example for system redundancy S2

- 1 Control system 1 (e.g. PLC)
- 2 Synchronization of control systems
- 3 Control system 2 (e.g. PLC)
- 4 Industrial Ethernet Managed Switch
- 5 Transmitter

FOUNDATION Fieldbus

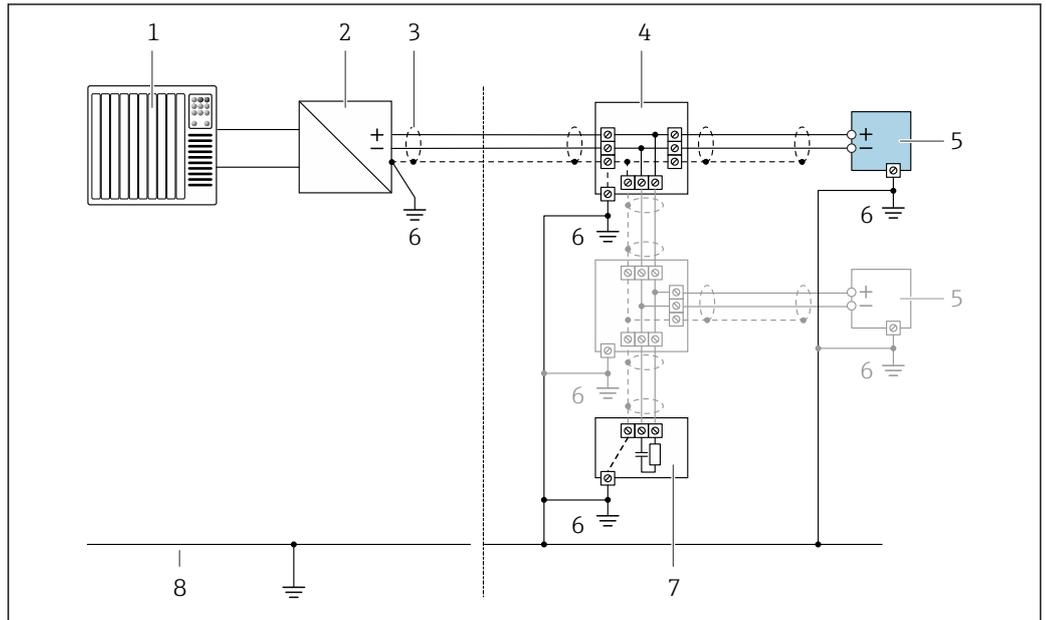

A0028768

11 Connection example for FOUNDATION Fieldbus

- 1 Control system (e.g. PLC)
- 2 Power Conditioner (FOUNDATION Fieldbus)
- 3 Cable shield provided at one end. The cable shield must be grounded at both ends to comply with EMC requirements; observe cable specifications
- 4 T-box
- 5 Measuring device
- 6 Local grounding
- 7 Bus terminator
- 8 Potential matching line

Modbus RS485

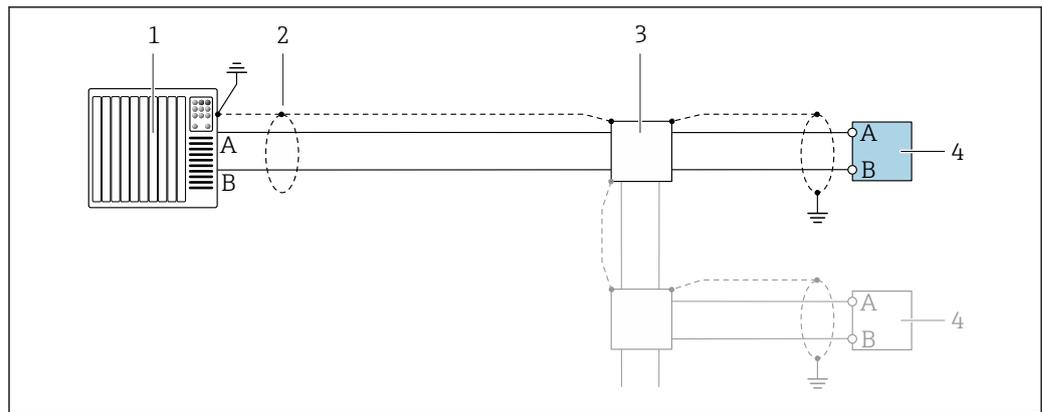

A0028765

12 Connection example for Modbus RS485, non-hazardous area and Zone 2/Div. 2

- 1 Control system (e.g. PLC)
- 2 Ground cable shield at one end. The cable shield must be grounded at both ends to comply with EMC requirements; observe cable specifications
- 3 Distribution box
- 4 Transmitter

Modbus with TCP-APL

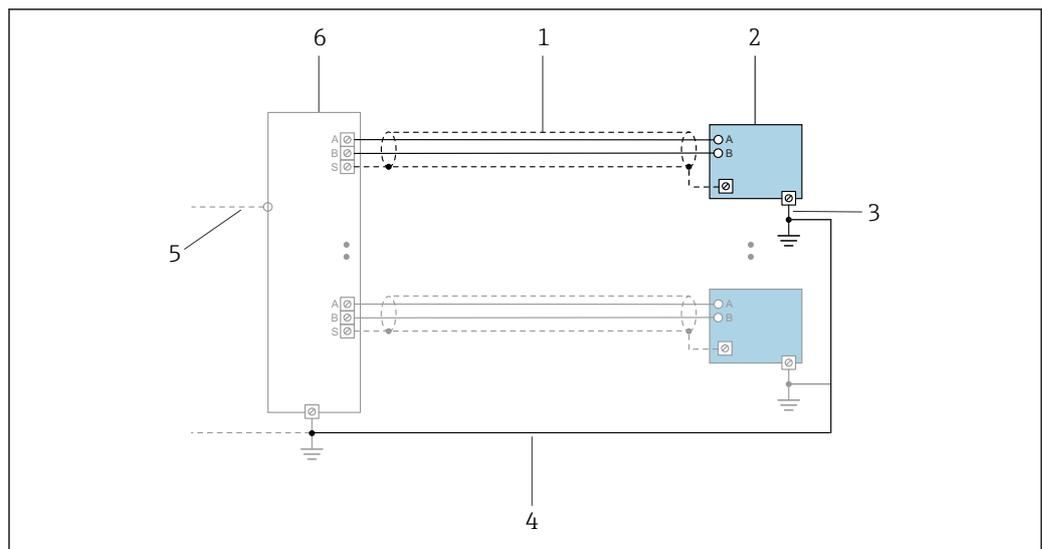

A0047536

13 Connection example for Modbus with TCP-APL

- 1 Cable shield
- 2 Measuring device
- 3 Local grounding
- 4 Potential equalization
- 5 Trunk or TCP
- 6 Field switch

Current output 4-20 mA

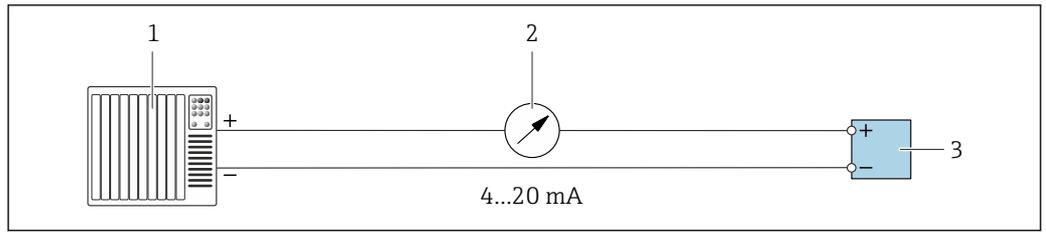

A0028758

14 Connection example for 4-20 mA current output (active)

- 1 Automation system with current input (e.g. PLC)
- 2 Analog display unit: observe maximum load → 16
- 3 Transmitter

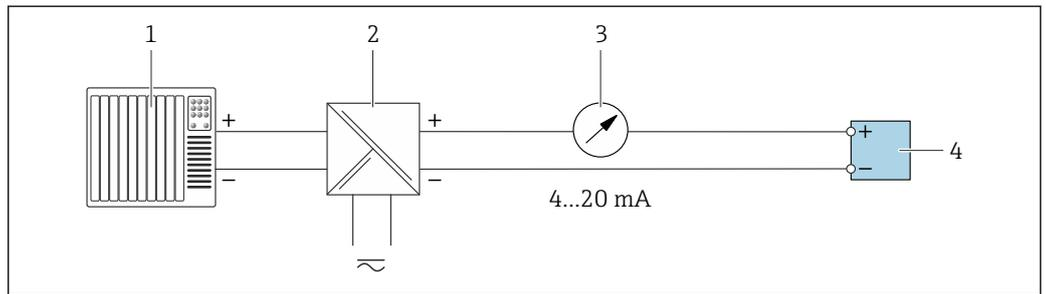

A0028759

15 Connection example for 4-20 mA current output (passive)

- 1 Automation system with current input (e.g. PLC)
- 2 Active barrier for power supply (e.g. RN221N)
- 3 Analog display unit: observe maximum load → 16
- 4 Transmitter

Pulse/frequency output

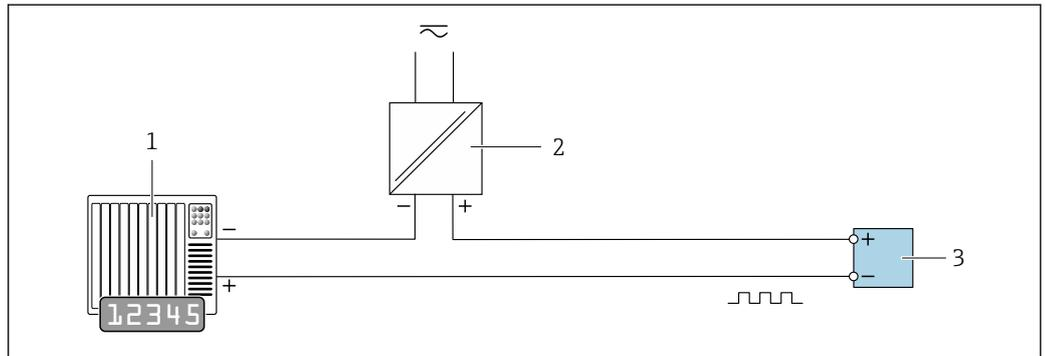

A0028761

16 Connection example for pulse/frequency output (passive)

- 1 Automation system with pulse/frequency input (e.g. PLC with 10 kΩ pull-up or pull-down resistor)
- 2 Power supply
- 3 Transmitter: observe input values → 19

Switch output

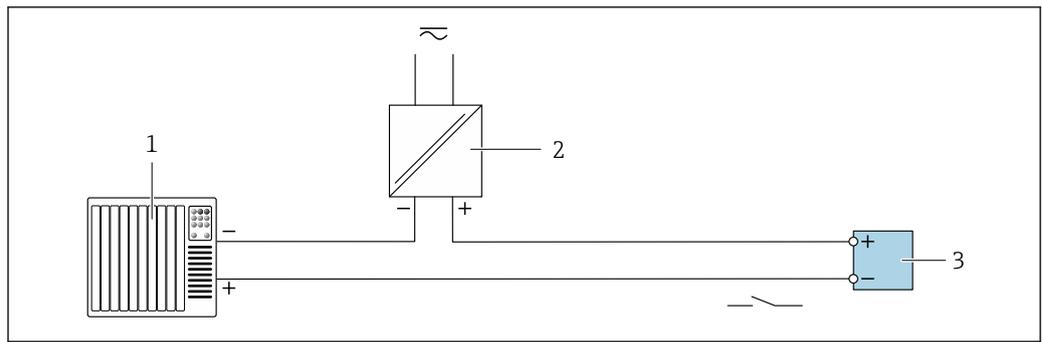

A0028760

17 Connection example for switch output (passive)

- 1 Automation system with switch input (e.g. PLC with a 10 kΩ pull-up or pull-down resistor)
- 2 Power supply
- 3 Transmitter: observe input values → 19

Double pulse output

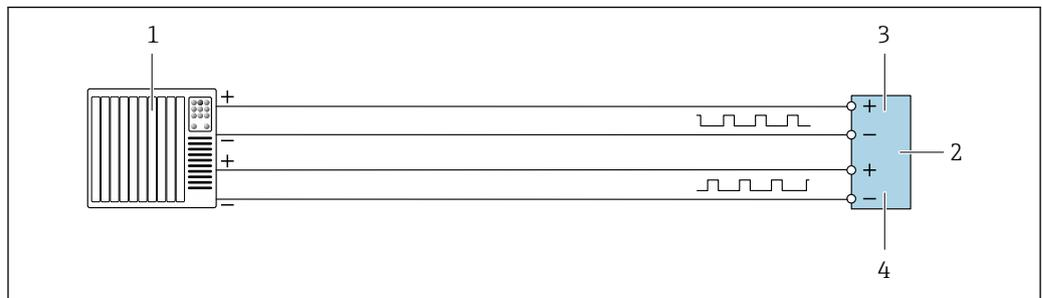

A0029280

18 Connection example for double pulse output (active)

- 1 Automation system with double pulse input (e.g. PLC)
- 2 Transmitter: observe input values → 20
- 3 Double pulse output
- 4 Double pulse output (slave), phase-shifted

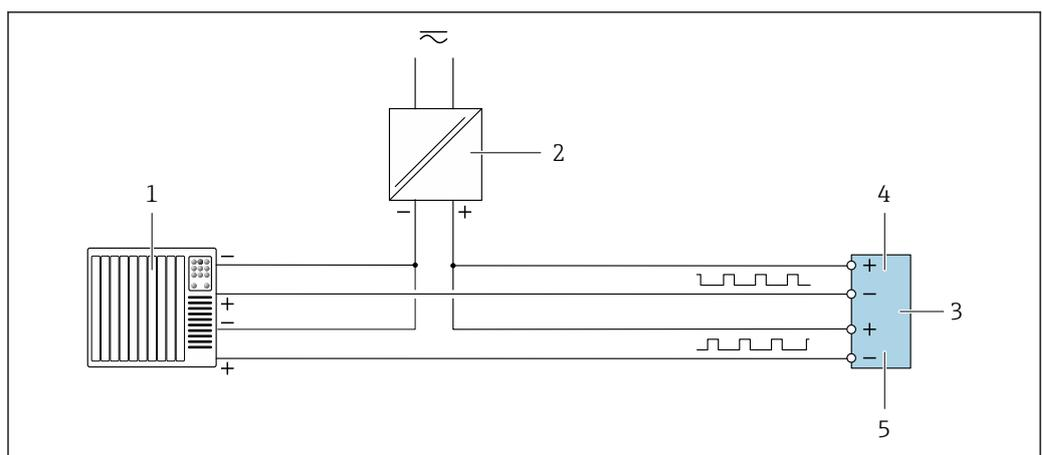

A0029279

19 Connection example for double pulse output (passive)

- 1 Automation system with double pulse input (e.g. PLC with a 10 kΩ pull-up or pull-down resistor)
- 2 Power supply
- 3 Transmitter: observe input values → 20
- 4 Double pulse output
- 5 Double pulse output (slave), phase-shifted

Relay output

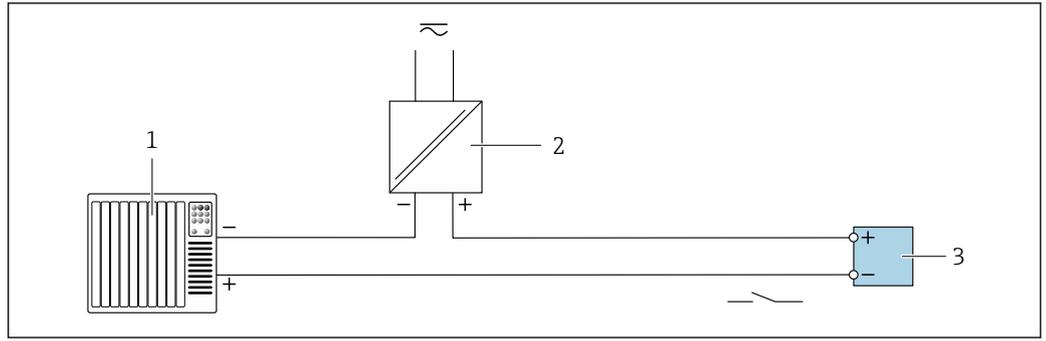

A0028760

20 Connection example for relay output (passive)

- 1 Automation system with relay input (e.g. PLC)
- 2 Power supply
- 3 Transmitter: observe input values → 21

Current input

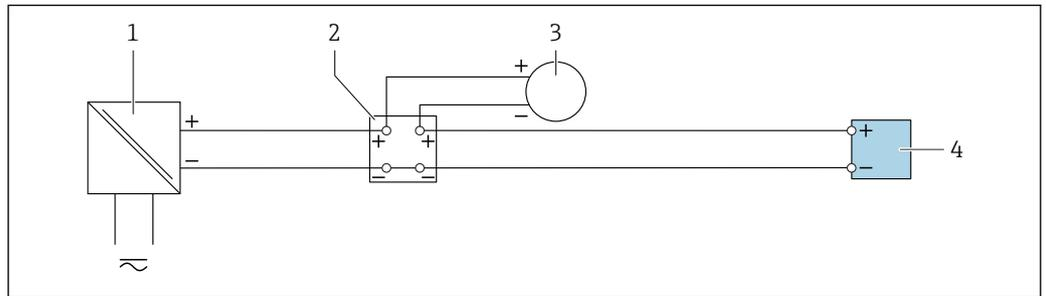

A0028915

21 Connection example for 4 to 20 mA current input

- 1 Power supply
- 2 Terminal box
- 3 External measuring device (to read in pressure or temperature, for instance)
- 4 Transmitter

Status input

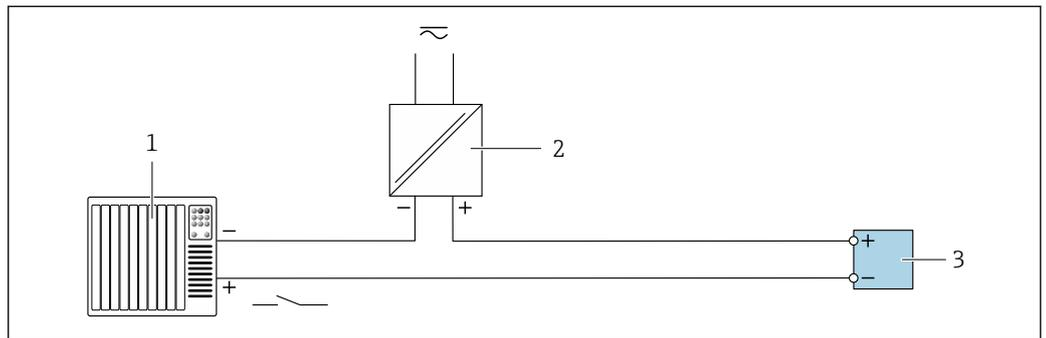

A0028764

22 Connection example for status input

- 1 Automation system with status output (e.g. PLC)
- 2 Power supply
- 3 Transmitter

Terminals

Spring-loaded terminals: Suitable for strands and strands with ferrules.
Conductor cross-section 0.2 to 2.5 mm² (24 to 12 AWG).

Cable entries

- Cable gland: M20 × 1.5 with cable \varnothing 6 to 12 mm (0.24 to 0.47 in)
- Thread for cable entry:
 - NPT 1/2"
 - G 1/2"
 - M20
- Device plug for digital communication: M12
Only available for certain device versions →  33.
- Device plug for connecting cable: M12
A device plug is always used for the device version with the order code for "Sensor connection housing", option C "Ultra-compact, hygienic, stainless".

Cable specification**Permitted temperature range**

- The installation guidelines that apply in the country of installation must be observed.
- The cables must be suitable for the minimum and maximum temperatures to be expected.

Power supply cable (incl. conductor for the inner ground terminal)

Standard installation cable is sufficient.

Protective grounding cable for the outer ground terminal

Conductor cross-section < 2.1 mm² (14 AWG)

The use of a cable lug enables the connection of larger cross-sections.

The grounding impedance must be less than 2 Ω .

Signal cable

Current output 4 to 20 mA HART

A shielded cable is recommended. Observe grounding concept of the plant.

PROFIBUS PA

Twisted, shielded two-wire cable. Cable type A is recommended .



For further information on planning and installing PROFIBUS networks see:

- Operating Instructions "PROFIBUS DP/PA: Guidelines for planning and commissioning" (BA00034S)
- PNO Directive 2.092 "PROFIBUS PA User and Installation Guideline"
- IEC 61158-2 (MBP)

PROFIBUS DP

The IEC 61158 standard specifies two types of cable (A and B) for the bus line which can be used for every transmission rate. Cable type A is recommended.

Cable type	A
Characteristic impedance	135 to 165 Ω at a measuring frequency of 3 to 20 MHz
Cable capacitance	< 30 pF/m
Wire cross-section	> 0.34 mm ² (22 AWG)
Cable type	Twisted pairs
Loop resistance	≤110 Ω /km
Signal damping	Max. 9 dB over the entire length of the cable cross-section
Shield	Copper braided shielding or braided shielding with foil shield. When grounding the cable shield, observe the grounding concept of the plant.



For further information on planning and installing PROFIBUS networks see:

- Operating Instructions "PROFIBUS DP/PA: Guidelines for planning and commissioning" (BA00034S)
- PNO Directive 2.092 "PROFIBUS PA User and Installation Guideline"
- IEC 61158-2 (MBP)

EtherNet/IP

The standard ANSI/TIA/EIA-568-B.2 Annex specifies CAT 5 as the minimum category for a cable used for EtherNet/IP. CAT 5e and CAT 6 are recommended.



For more information on planning and installing EtherNet/IP networks, please refer to the "Media Planning and Installation Manual. EtherNet/IP" of ODVA Organization

PROFINET

Standard IEC 61156-6 specifies CAT 5 as the minimum category for a cable used for PROFINET. CAT 5e and CAT 6 are recommended.



For more information on planning and installing PROFINET networks, see: "PROFINET Cabling and Interconnection Technology", Guideline for PROFINET

PROFINET over Ethernet-APL

The reference cable type for APL segments is fieldbus cable type A, MAU type 1 and 3 (specified in IEC 61158-2). This cable meets the requirements for intrinsically safe applications according to IEC TS 60079-47 and can also be used in non-intrinsically safe applications.

Cable type	A
Cable capacitance	45 to 200 nF/km
Loop resistance	15 to 150 Ω/km
Cable inductance	0.4 to 1 mH/km

Further details are provided in the Ethernet-APL Engineering Guideline (<https://www.ethernet-apl.org>).

Modbus TCP-APL

The reference cable type for APL segments is fieldbus cable type A, MAU type 1 and 3 (specified in IEC 61158-2). This cable meets the requirements for intrinsically safe applications according to IEC TS 60079-47 and can also be used in non-intrinsically safe applications.

Cable type	A
Cable capacitance	45 to 200 nF/km
Loop resistance	15 to 150 Ω/km
Cable inductance	0.4 to 1 mH/km

Further details are provided in the Ethernet-APL Engineering Guideline (<https://www.ethernet-apl.org>).

FOUNDATION Fieldbus

Twisted, shielded two-wire cable.



For further information on planning and installing FOUNDATION Fieldbus networks see:

- Operating Instructions for "FOUNDATION Fieldbus Overview" (BA00013S)
- FOUNDATION Fieldbus Guideline
- IEC 61158-2 (MBP)

Modbus RS485

The EIA/TIA-485 standard specifies two types of cable (A and B) for the bus line which can be used for every transmission rate. Cable type A is recommended.

Cable type	A
Characteristic impedance	135 to 165 Ω at a measuring frequency of 3 to 20 MHz
Cable capacitance	< 30 pF/m
Wire cross-section	> 0.34 mm ² (22 AWG)

Cable type	Twisted pairs
Loop resistance	$\leq 110 \Omega/\text{km}$
Signal damping	Max. 9 dB over the entire length of the cable cross-section
Shield	Copper braided shielding or braided shielding with foil shield. When grounding the cable shield, observe the grounding concept of the plant.

Current output 0/4 to 20 mA

Standard installation cable is sufficient.

Pulse /frequency /switch output

Standard installation cable is sufficient.

Double pulse output

Standard installation cable is sufficient.

Relay output

Standard installation cable is sufficient.

Current input 0/4 to 20 mA

Standard installation cable is sufficient.

Status input

Standard installation cable is sufficient.

Choice of connecting cable between the transmitter and sensor

Depends on the type of transmitter and the installation zones

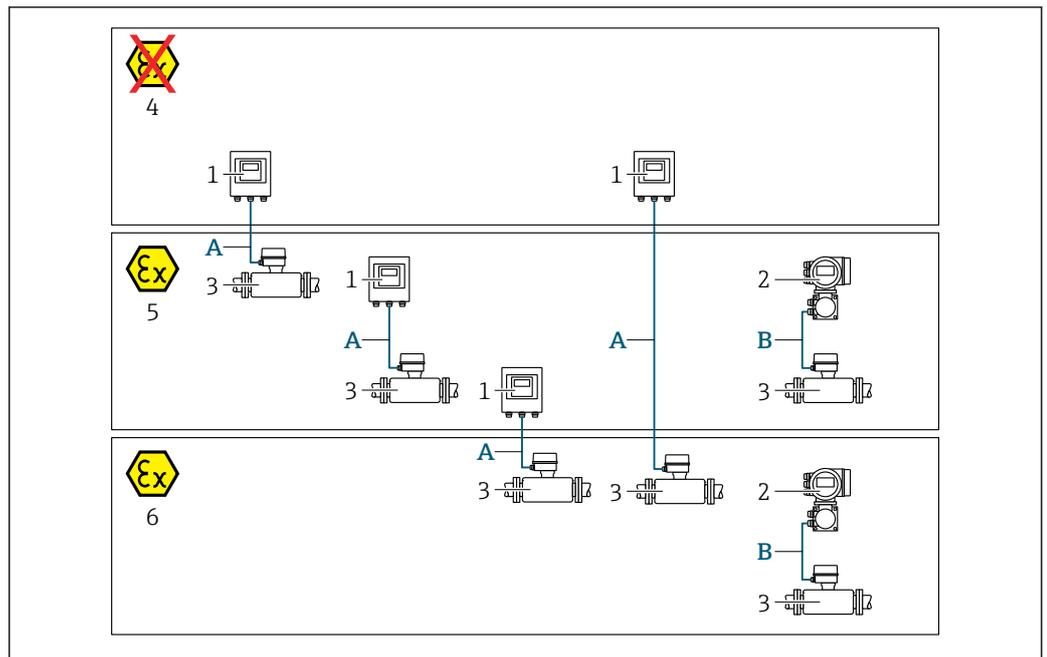

A0032477

- 1 Proline 500 digital transmitter
- 2 Proline 500 transmitter
- 3 Promag sensor
- 4 Non-hazardous area
- 5 Hazardous area: Zone 2; Class I, Division 2
- 6 Hazardous area: Zone 1; Class I, Division 1
- A Standard cable to 500 digital transmitter → 53
Transmitter installed in the non-hazardous area or hazardous area: Zone 2; Class I, Division 2 / sensor installed in the hazardous area: Zone 2; Class I, Division 2 or Zone 1; Class I, Division 1
- B Signal cable to 500 transmitter → 54
Transmitter and sensor installed in the hazardous area: Zone 2; Class I, Division 2 or Zone 1; Class I, Division 1

A: Connecting cable between sensor and transmitter: Proline 500 – digital

Standard cable

A standard cable with the following specifications can be used as the connecting cable.

Design	4 cores (2 pairs); uninsulated stranded CU wires; pair-stranded with common shield
Shielding	Tin-plated copper braid, optical cover ≥ 85 %
Cable length	Maximum 300 m (900 ft), see the following table.

Cross-section	Cable lengths for use in	
	Non-hazardous area, Hazardous area: Zone 2; Class I, Division 2	Hazardous area: Zone 1; Class I, Division 1
0.34 mm ² (AWG 22)	80 m (240 ft)	50 m (150 ft)
0.50 mm ² (AWG 20)	120 m (360 ft)	60 m (180 ft)
0.75 mm ² (AWG 18)	180 m (540 ft)	90 m (270 ft)
1.00 mm ² (AWG 17)	240 m (720 ft)	120 m (360 ft)

Cross-section	Cable lengths for use in	
	Non-hazardous area, Hazardous area: Zone 2; Class I, Division 2	Hazardous area: Zone 1; Class I, Division 1
1.50 mm ² (AWG 15)	300 m (900 ft)	180 m (540 ft)
2.50 mm ² (AWG 13)	300 m (900 ft)	300 m (900 ft)

Optionally available connecting cable

Design	2 × 2 × 0.34 mm ² (AWG 22) PVC cable ¹⁾ with common shield (2 pairs, uninsulated stranded CU wires; pair-stranded)
Flame resistance	According to DIN EN 60332-1-2
Oil-resistance	According to DIN EN 60811-2-1
Shielding	Tin-plated copper braid, optical cover ≥ 85 %
Operating temperature	When mounted in a fixed position: -50 to +105 °C (-58 to +221 °F); when cable can move freely: -25 to +105 °C (-13 to +221 °F)
Available cable length	Fixed: 20 m (60 ft); variable: up to maximum 50 m (150 ft)

1) UV radiation can impair the cable outer sheath. Protect the cable from direct sunshine where possible.

B: Connecting cable between sensor and transmitter: Proline 500

Signal cable

Design	3 × 0.38 mm ² (20 AWG) with common, braided copper shield (∅ ~ 9.5 mm (0.37 in)) and individual shielded cores
Conductor resistance	≤ 50 Ω/km (0.015 Ω/ft)
Capacitance: core/shield	≤ 420 pF/m (128 pF/ft)
Cable length (max.)	Depends on the medium conductivity, max. 200 m (656 ft)
Cable lengths (available for order)	5 m (15 ft), 10 m (30 ft), 20 m (60 ft) or variable length up to max. 200 m (600 ft)
Cable diameter	9.4 mm (0.37 in) ± 0.5 mm (0.02 in)
Operating temperature	-20 to +80 °C (-4 to +176 °F)

Coil current cable

Design	3 × 0.75 mm ² (18 AWG) with common, braided copper shield (∅ ~ 9 mm (0.35 in)) and individual shielded cores
Conductor resistance	≤ 37 Ω/km (0.011 Ω/ft)
Capacitance: core/core, shield grounded	≤ 120 pF/m (37 pF/ft)
Cable length (max.)	Depends on the medium conductivity, max. 200 m (656 ft)
Cable lengths (available for order)	5 m (15 ft), 10 m (30 ft), 20 m (60 ft) or variable length up to max. 200 m (600 ft)
Cable diameter	8.8 mm (0.35 in) ± 0.5 mm (0.02 in)
Continuous operating temperature	-20 to +80 °C (-4 to +176 °F)
Test voltage for cable insulation	≤ AC 1433 V rms 50/60 Hz or ≥ DC 2026 V

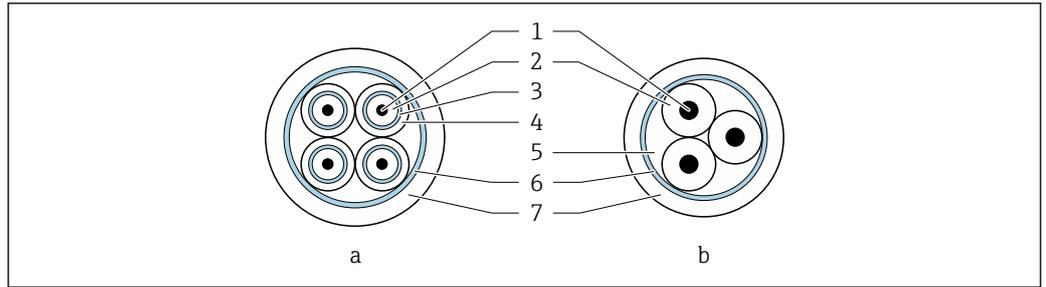

A0029151

23 Cable cross-section

- a Electrode cable
- b Coil current cable
- 1 Core
- 2 Core insulation
- 3 Core shield
- 4 Core jacket
- 5 Core reinforcement
- 6 Cable shield
- 7 Outer jacket

Operation in zones of severe electrical interference

The measuring system meets the general safety requirements → 133 and EMC specifications → 67.

Grounding is by means of the ground terminal provided for the purpose inside the connection housing. The stripped and twisted lengths of cable shield to the ground terminal must be as short as possible.

Overvoltage protection

Mains voltage fluctuations	→ 36
Overvoltage category	Overvoltage category II
Short-term, temporary overvoltage	Between cable and ground up to 1200 V, for max. 5 s
Long-term, temporary overvoltage	Between cable and ground up to 500 V

Performance characteristics

Reference operating conditions

- Error limits following DIN EN 29104, in future ISO 20456
- Water, typically: +15 to +45 °C (+59 to +113 °F); 0.5 to 7 bar (73 to 101 psi)
- Data as indicated in the calibration protocol
- Accuracy based on accredited calibration rigs according to ISO 17025
- Reference temperature for conductivity measurement: 25 °C (77 °F)

Maximum measurement error

o.r. = of reading

Maximum permissible error under reference operating conditions

Volume flow

- ±0.5 % o.r. ± 1 mm/s (0.04 in/s)
- Optional: ±0.2 % o.r. ± 2 mm/s (0.08 in/s)



Fluctuations in the supply voltage do not have any effect within the specified range.

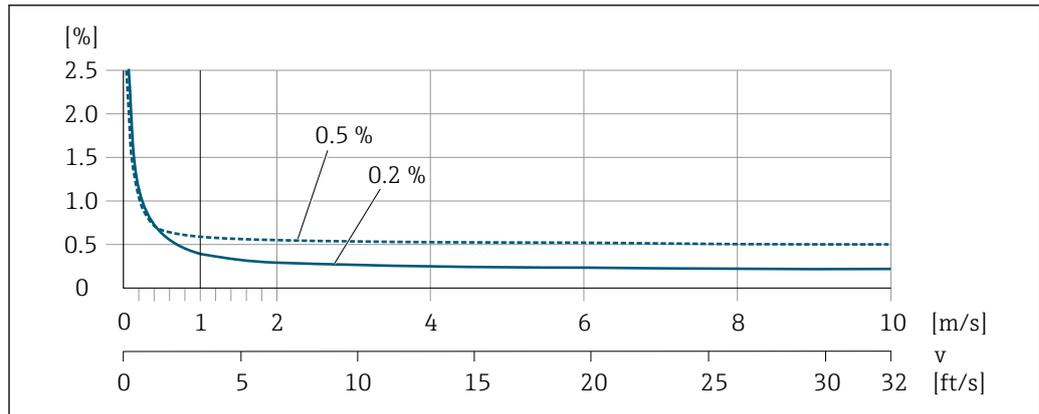

A0028974

24 Maximum measured error in % o.r.

Temperature

±3 °C (±5.4 °F)

Electrical conductivity

The values apply for:

- Devices with stainless steel process connections
- Proline 500 – digital device version
- Measurements at a reference temperature of 25 °C (77 °F). At different temperatures, attention must be paid to the temperature coefficient of the medium (typically 2.1 %/K)

Conductivity [μS/cm]	Nominal diameter		Measurement error [%] of reading
	[mm]	[in]	
5 to 20	15...150	½...6	± 20%
> 20 to 50	15...150	½...6	± 10%
> 50 to 10 000	2...8	¼ ₁₂ to 5/16	± 10%
	15...150	½...6	<ul style="list-style-type: none"> ■ Standard: ± 10% ■ Optional ¹⁾: ± 5%
> 10 000 to 20 000	2...150	¼ ₁₂ to 6	± 10%
> 20 000 to 100 000	2...150	¼ ₁₂ to 6	± 20%

1) Order code for "Calibrated conductivity measurement", option CW

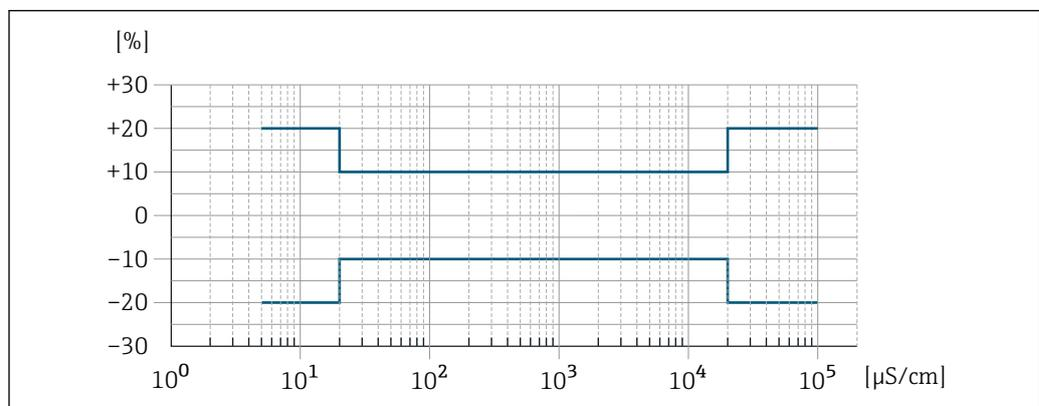

A0042279

25 Measurement error (standard)

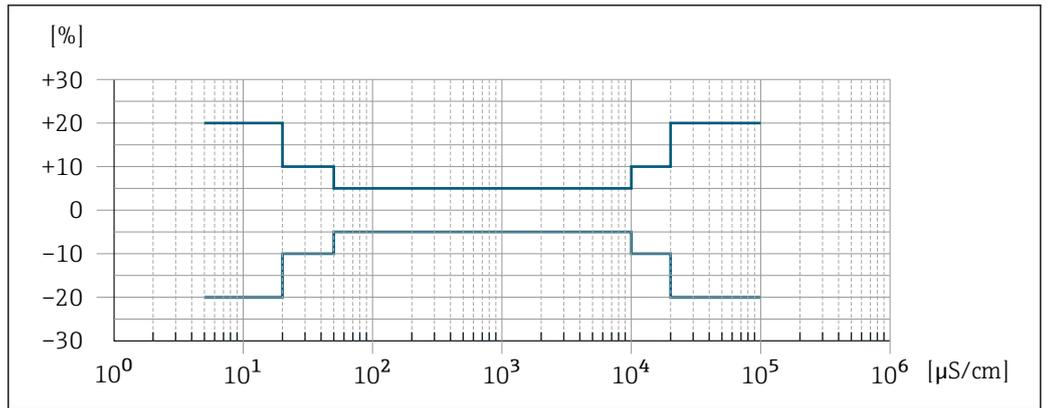

26 Measurement error (optional: order code for "Calibrated conductivity measurement", option CW)

Accuracy of outputs

The outputs have the following base accuracy specifications.

Current output

Accuracy	±5 μA
-----------------	-------

Pulse/frequency output

o.r. = of reading

Accuracy	Max. ±50 ppm o.r. (over the entire ambient temperature range)
-----------------	---

Repeatability

o.r. = of reading

Volume flow

Max. ±0.1 % o.r. ± 0.5 mm/s (0.02 in/s)

Temperature

±0.5 °C (±0.9 °F)

Electrical conductivity

- Max. ±5 % o.r.
- Max. ±1 % o.r. for DN 15 to 150 in conjunction with process connections made of stainless steel 1.4404 (F316L)

Temperature measurement response time

T₉₀ < 15 s

Influence of ambient temperature

Current output

Temperature coefficient	Max. 1 μA/°C
--------------------------------	--------------

Pulse/frequency output

Temperature coefficient	No additional effect. Included in accuracy.
--------------------------------	---

Mounting

Mounting location

- Do not install the device at the highest point of the pipe.
- Do not install the device upstream from a free pipe outlet in a down pipe.

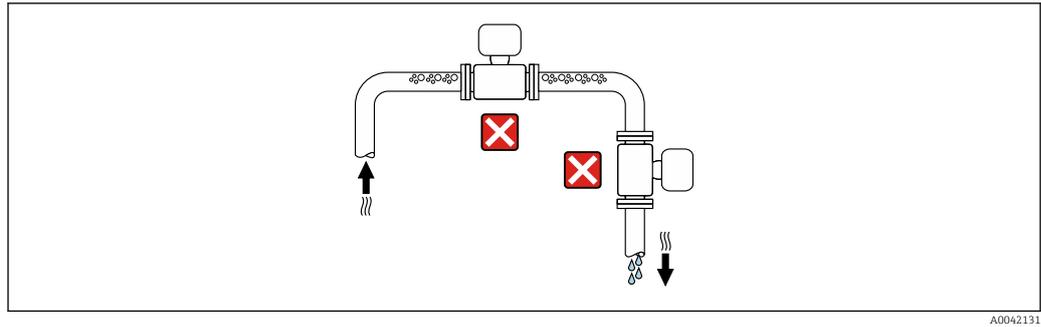

A0042131

The device should ideally be installed in an ascending pipe.

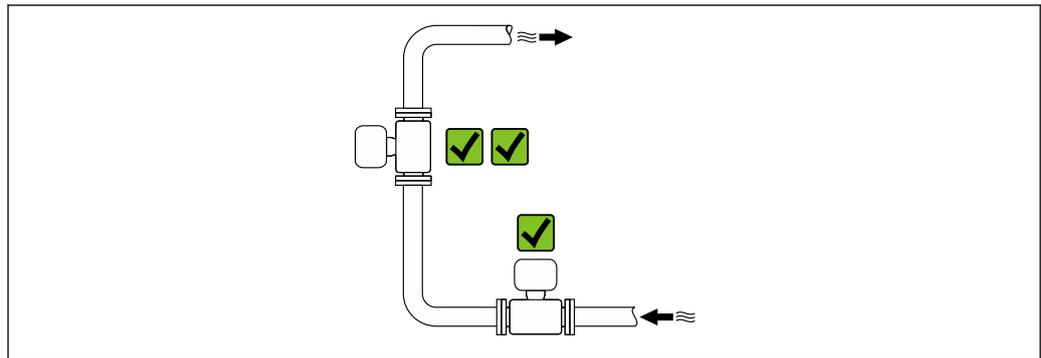

A0042137

Installation upstream from a down pipe

NOTICE

Negative pressure in the measuring pipe can damage the liner!

- ▶ If installing upstream of down pipes whose length $h \geq 5$ m (16.4 ft): install a siphon with a vent valve downstream of the device.

 This arrangement prevents the flow of liquid stopping in the pipe and air entrainment.

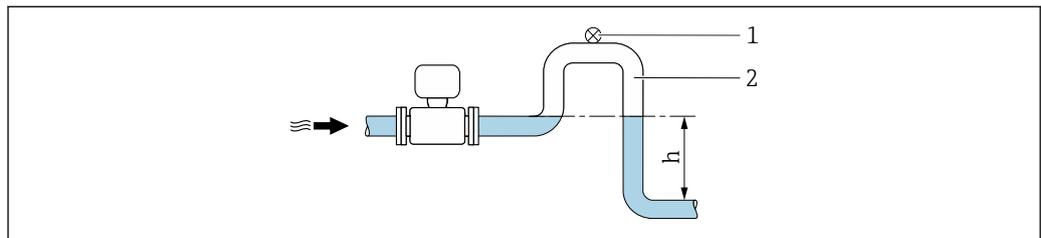

A0028981

- 1 Vent valve
- 2 Pipe siphon
- h Length of down pipe

Installation with partially filled pipes

- Partially filled pipes with a gradient require a drain-type configuration.
- The installation of a cleaning valve is recommended.

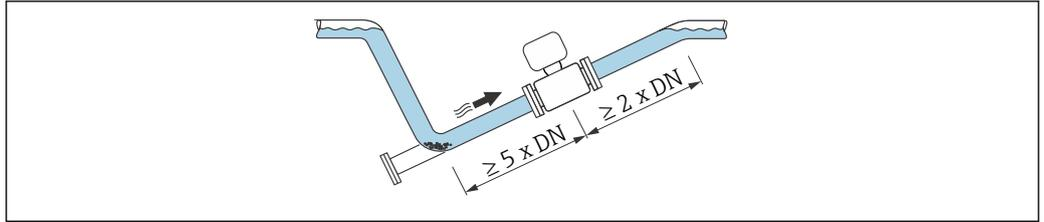

A0041088

Installation near pumps

NOTICE

Negative pressure in the measuring tube can damage the liner!

- ▶ In order to maintain the system pressure, install the device in the flow direction downstream from the pump.
- ▶ Install pulsation dampers if reciprocating, diaphragm or peristaltic pumps are used.

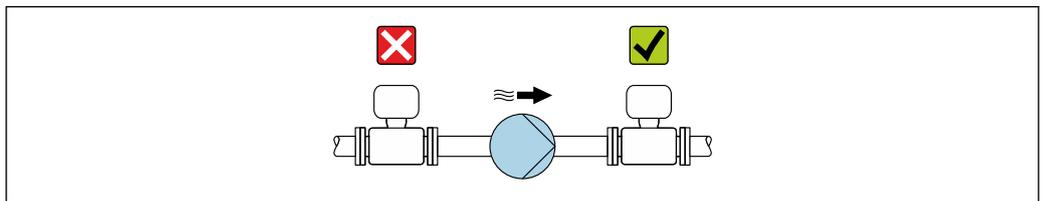

A0041083



- Information on the liner's resistance to partial vacuum
- Information on the measuring system's resistance to vibration and shock → 66

Installation in event of pipe vibrations

NOTICE

Pipe vibrations can damage the device!

- ▶ Do not expose the device to strong vibrations.
- ▶ Support the pipe and fix it in place.
- ▶ Support the device and fix it in place.

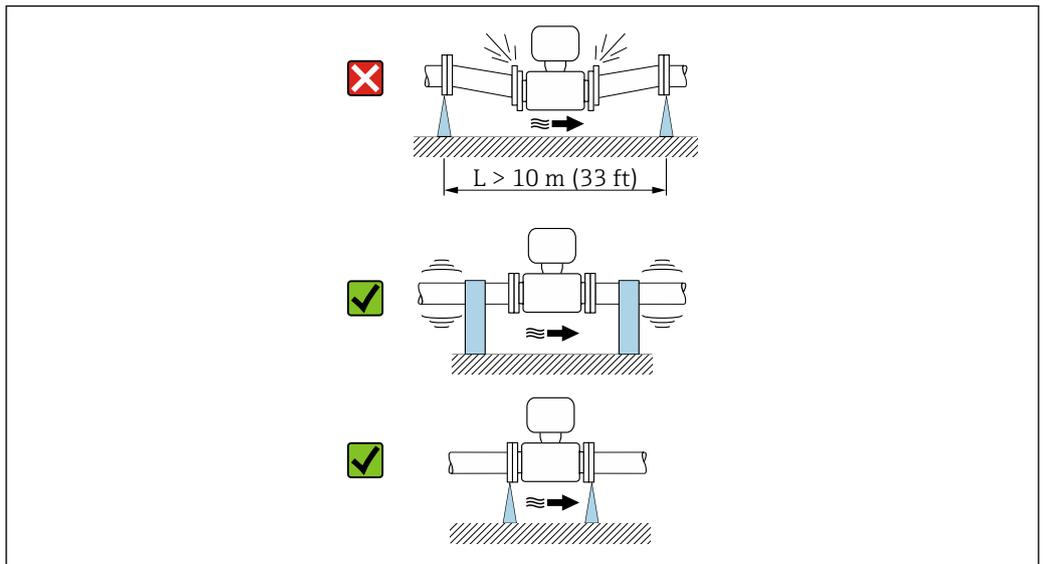

A0041092



- Information on the measuring system's resistance to vibration and shock → 66

Orientation

The direction of the arrow on the nameplate helps you to install the measuring device according to the flow direction (direction of medium flow through the piping).

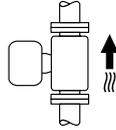
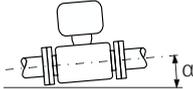
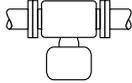
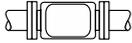
Orientation		Recommendation
Vertical orientation	 <p style="text-align: right; font-size: small;">A0015591</p>	<input checked="" type="checkbox"/> <input checked="" type="checkbox"/>
Horizontal orientation	 <p style="text-align: right; font-size: small;">A0041328</p>	<input checked="" type="checkbox"/> 1)
Horizontal orientation, transmitter at bottom	 <p style="text-align: right; font-size: small;">A0015590</p>	<input checked="" type="checkbox"/> <input checked="" type="checkbox"/> 2) 3) <input checked="" type="checkbox"/> 4)
Horizontal orientation, transmitter at side	 <p style="text-align: right; font-size: small;">A0015592</p>	<input checked="" type="checkbox"/>

- 1) The measuring device should be self-draining for hygiene applications. A vertical orientation is recommended for this. If only a horizontal orientation is possible, an angle of inclination $\alpha \geq 10^\circ$ is recommended.
- 2) Applications with high process temperatures may increase the ambient temperature. To maintain the maximum ambient temperature for the transmitter, this orientation is recommended.
- 3) To prevent the electronics from overheating in the event of strong heat formation (e.g. CIP or SIP cleaning process), install the device with the transmitter part pointing downwards.
- 4) With the empty pipe detection function switched on: empty pipe detection only works if the transmitter housing is pointing upwards.

Vertical

Optimum for self-emptying pipe systems and for use in conjunction with empty pipe detection.

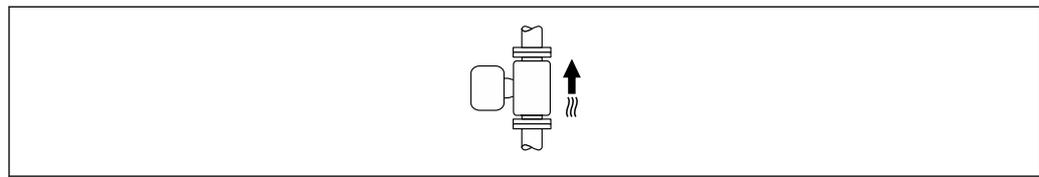

A0015591

Horizontal

- Ideally, the measuring electrode plane should be horizontal. This prevents brief insulation of the measuring electrodes by entrained air bubbles.
- Empty pipe detection only works if the transmitter housing is pointing upwards as otherwise there is no guarantee that the empty pipe detection function will actually respond to a partially filled or empty measuring tube.

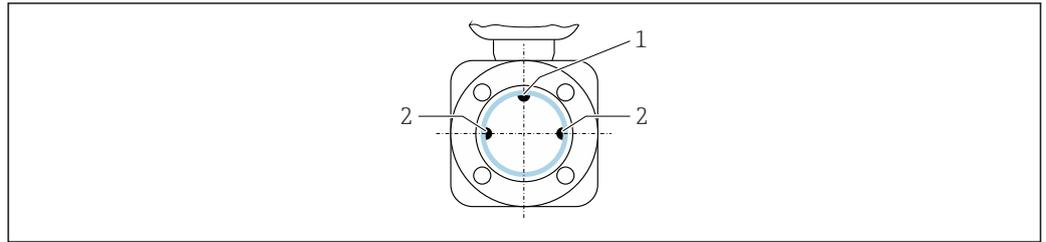

A0028998

- 1 EPD electrode for empty pipe detection, available from \geq DN 15 (1/2")
- 2 Measuring electrodes for signal detection

i Measuring instruments with a nominal diameter $<$ DN 15 (1/2") do not have an EPD electrode. In this case, empty pipe detection is performed via the measuring electrodes.

Inlet and outlet runs

Installation with inlet and outlet runs

To avoid a vacuum and to maintain the specified level of measurement accuracy, install the device upstream from assemblies that produce turbulence (e.g. valves, T-sections) and downstream from pumps.

Maintain straight, unimpeded inlet and outlet runs.

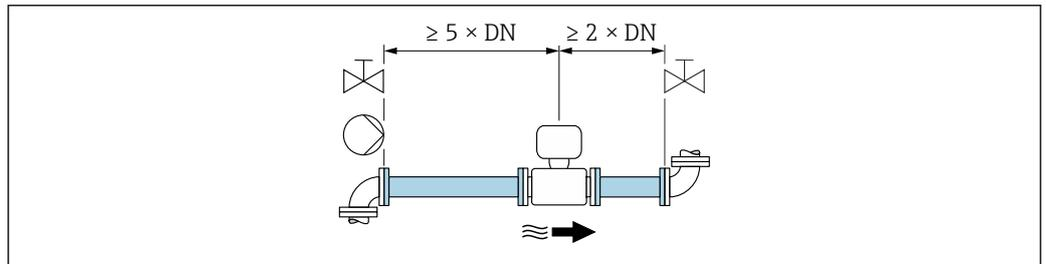

A0028997

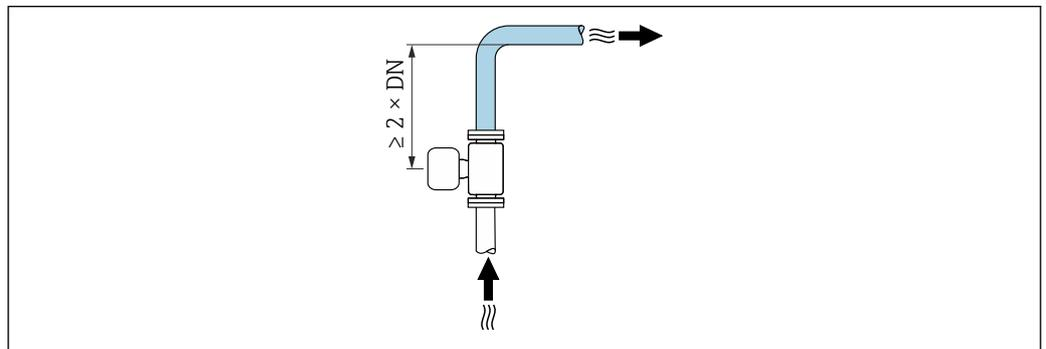

A0042132

Adapters

The sensor can also be installed in larger-diameter pipes with the aid of suitable adapters according to DIN EN 545 (double-flange reducers). The resultant increase in the rate of flow improves measuring accuracy with very slow-moving fluids.

The nomogram shown here can be used to calculate the pressure loss caused by reducers and expanders:

- Calculate the ratio of the diameters d/D .
 - From the nomogram read off the pressure loss as a function of flow velocity (downstream from the reduction) and the d/D ratio.
- i**
- The nomogram only applies to liquids with a viscosity similar to that of water.
 - If the medium has a high viscosity, a larger measuring tube diameter can be considered in order to reduce pressure loss.

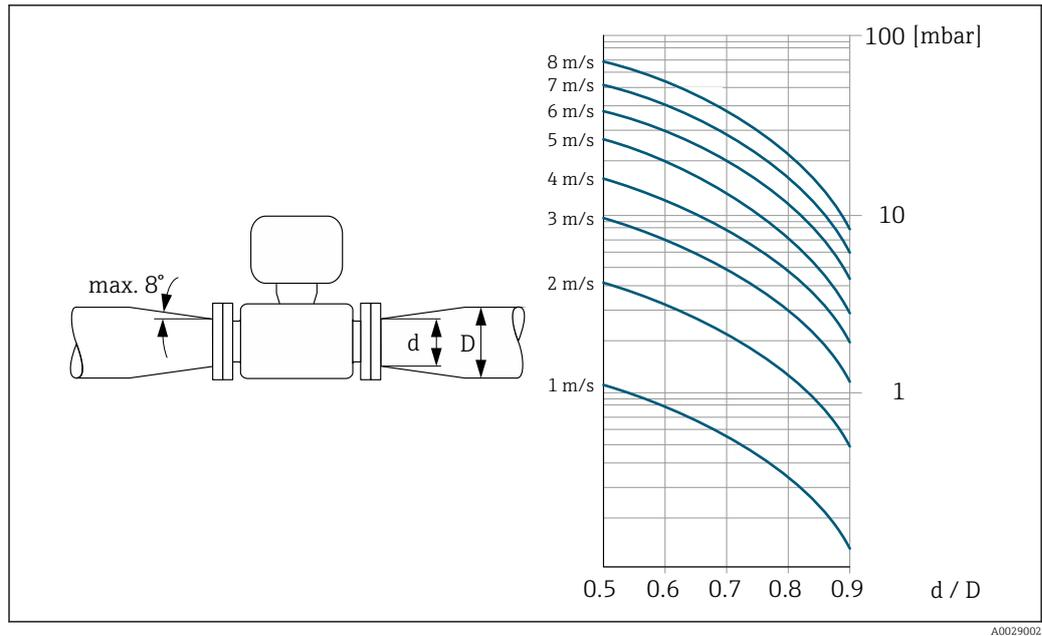

Length of connecting cable

Proline 500 – digital transmitter

Lengths of connecting cable → 53

Proline 500 transmitter

Max. 200 m (650 ft)

To obtain correct measurement results, observe the permitted connecting cable length of L_{max} . This length is determined by the conductivity of the medium. If measuring liquids in general: $5 \mu S/cm$

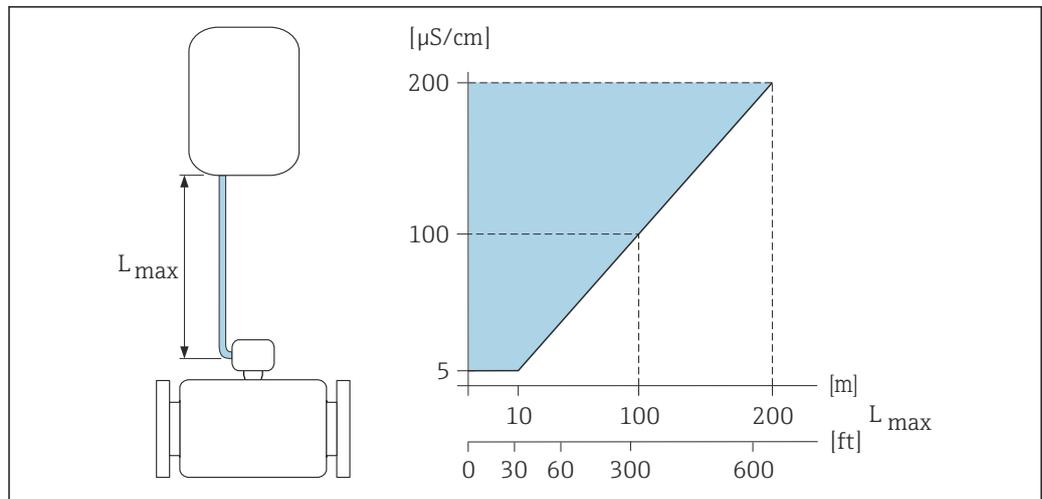

27 Permitted length of connecting cable

Colored area = permitted range

L_{max} = length of connecting cable in [m] ([ft])

[$\mu S/cm$] = medium conductivity

Mounting the transmitter housing

Proline 500 – digital transmitter

Pipe mounting

Required tools:

- Open-ended wrench AF 10
- Torx screwdriver TX 25

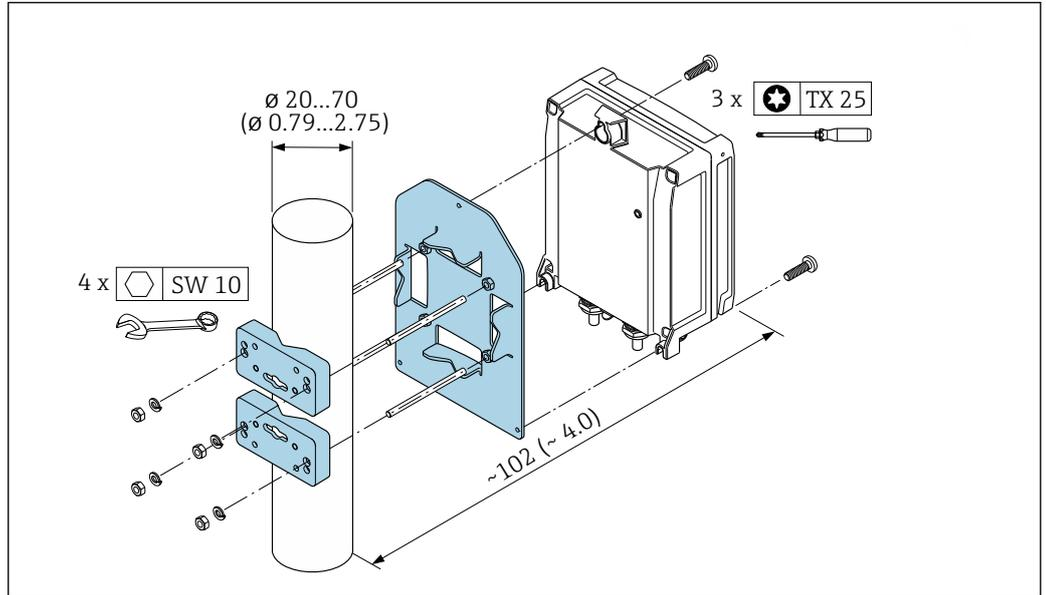

A0029051

28 Unit mm (in)

Wall mounting

Required tools:

Drill with drill bit $\varnothing 6.0$ mm

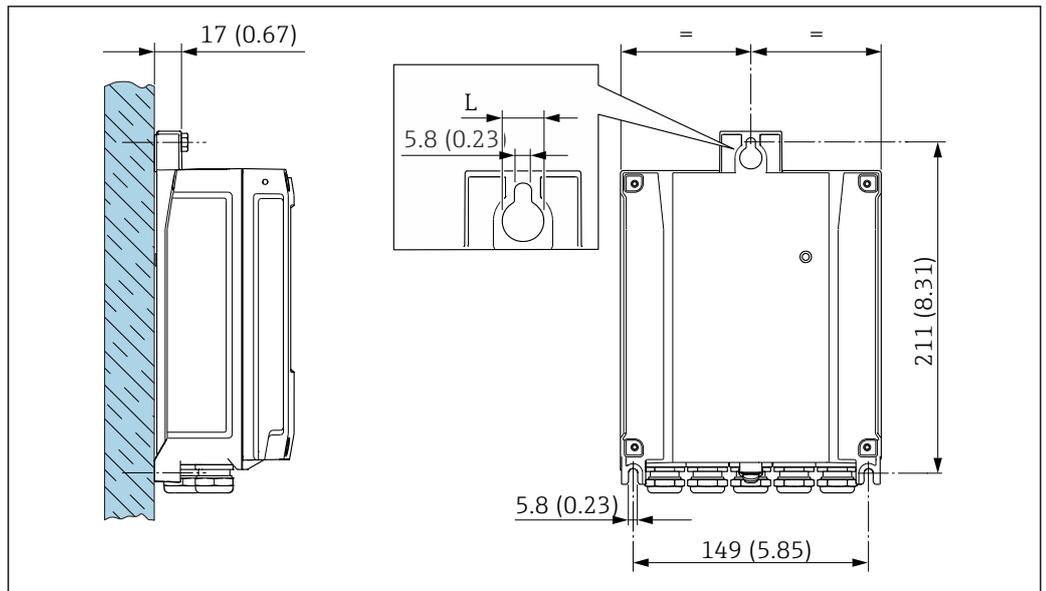

A0029054

29 Engineering unit mm (in)

L Depends on order code for "Transmitter housing"

Order code for "Transmitter housing"

Option A, aluminum, coated: L = 14 mm (0.55 in)

Proline 500 transmitter

Pipe mounting

Required tools
Open-ended wrench AF 13

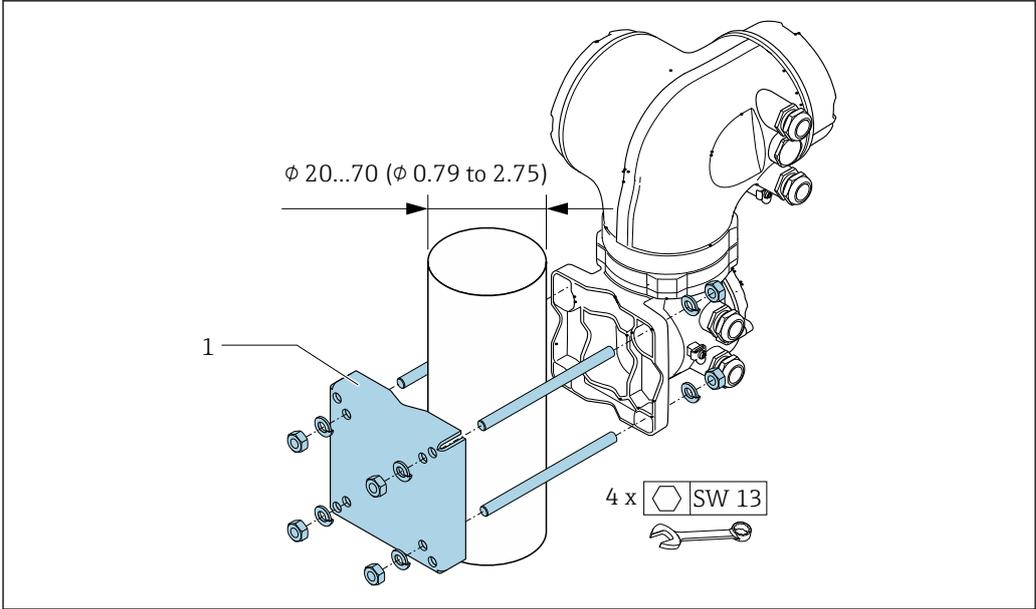

A0029057

30 Engineering unit mm (in)

Wall mounting

Required tools
Drill with drill bit $\phi 6.0$ mm

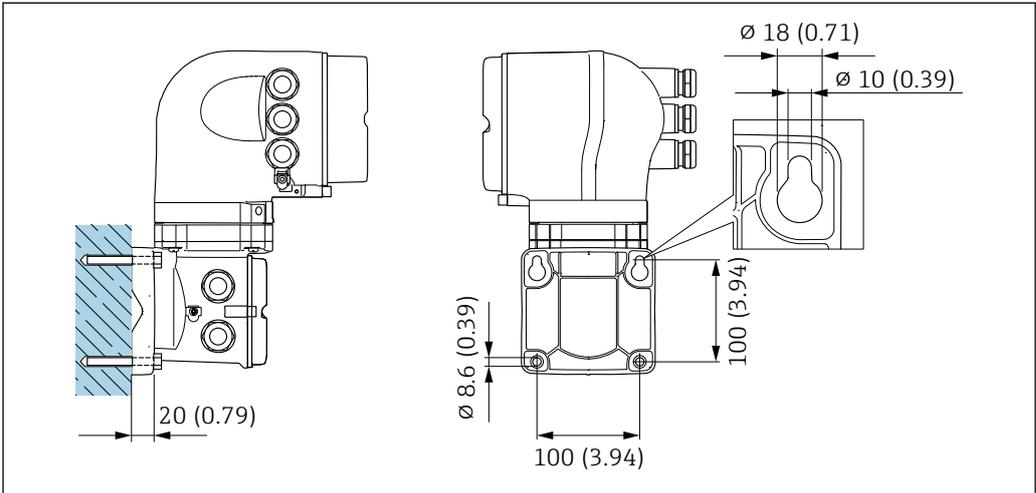

A0029068

31 Engineering unit mm (in)

Special mounting instructions

Weather protection cover

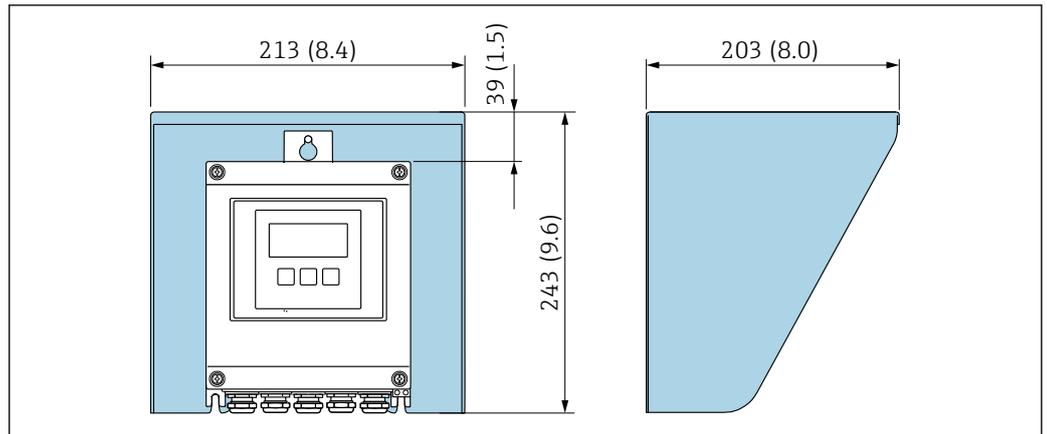

A0029552

32 Weather protection cover for Proline 500 – digital; engineering unit mm (in)

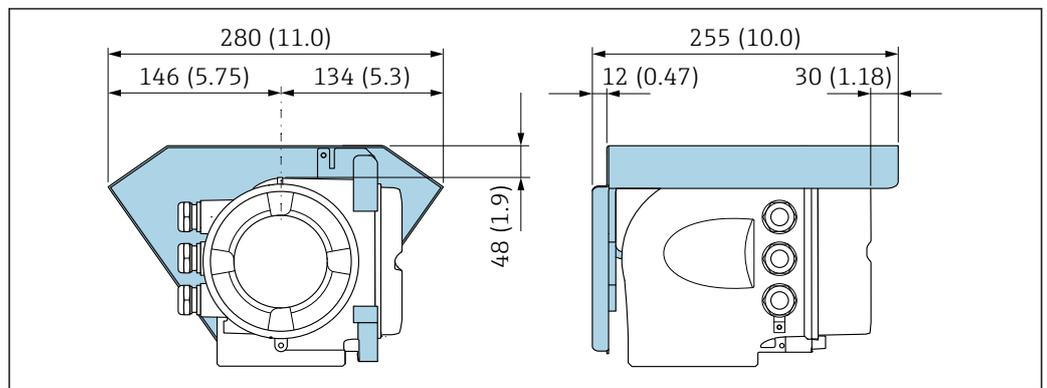

A0029553

33 Weather protection cover for Proline 500; engineering unit mm (in)

Hygienic compatibility

i When installing in hygienic applications, please refer to the information in the "Certificates and approvals/hygienic compatibility" section → 131

Environment

Ambient temperature range

Transmitter	<ul style="list-style-type: none"> Standard: -40 to +60 °C (-40 to +140 °F) Optional: -50 to +60 °C (-58 to +140 °F) (Order code for "Test, certificate", option JN "Ambient temperature of transmitter -50 °C (-58 °F)")
Local display	-20 to +60 °C (-4 to +140 °F), the readability of the display may be impaired at temperatures outside the temperature range.
Sensor	-40 to +60 °C (-40 to +140 °F) If both the ambient and the medium temperatures are high, mount the sensor separately from the transmitter.
Liner	Do not exceed or fall below the permitted temperature range of the liner .

If operating outdoors:

- Install the measuring device in a shady location.
- Avoid direct sunlight, particularly in warm climatic regions.
- Avoid direct exposure to weather conditions.

Storage temperature	<p>The storage temperature corresponds to the operating temperature range of the transmitter and the sensor →  65.</p> <ul style="list-style-type: none"> ▪ Protect the measuring device against direct sunlight during storage in order to avoid unacceptably high surface temperatures. ▪ Select a storage location where moisture cannot collect in the measuring device as fungus or bacteria infestation can damage the liner. ▪ If protection caps or protective covers are mounted these should never be removed before installing the measuring device.
Atmosphere	<p>Additional protection against condensation and moisture: the sensor housing is potted with a gel. Order code for "Sensor option", option CF "Harsh environment".</p>
Relative humidity	<p>The device is suitable for use outdoors and indoors with a relative humidity of 4 to 95 %.</p>
Operating height	<p>According to EN 61010-1</p> <ul style="list-style-type: none"> ▪ ≤ 2 000 m (6 562 ft) ▪ > 2 000 m (6 562 ft) with additional overvoltage protection (e.g. Endress+Hauser HAW Series)
Degree of protection	<p>Transmitter</p> <ul style="list-style-type: none"> ▪ IP66/67, Type 4X enclosure, suitable for pollution degree 4 ▪ When the housing is open: IP20, Type 1 enclosure, suitable for pollution degree 2 ▪ Display module: IP20, Type 1 enclosure, suitable for pollution degree 2 <p>Sensor</p> <ul style="list-style-type: none"> ▪ IP66/67, Type 4X enclosure, suitable for pollution degree 4 ▪ When the housing is open: IP20, Type 1 enclosure, suitable for pollution degree 2 <p>External WLAN antenna</p> <p>IP67</p>
Vibration-resistance and shock-resistance	<p>Vibration sinusoidal, in accordance with IEC 60068-2-6</p> <ul style="list-style-type: none"> ▪ 2 to 8.4 Hz, 7.5 mm peak ▪ 8.4 to 2 000 Hz, 2 g peak <p>Vibration broad-band random, according to IEC 60068-2-64</p> <ul style="list-style-type: none"> ▪ 10 to 200 Hz, 0.01 g²/Hz ▪ 200 to 2 000 Hz, 0.003 g²/Hz ▪ Total: 2.70 g rms <p>Shock half-sine, according to IEC 60068-2-27</p> <p>6 ms 50 g</p> <p>Rough handling shocks according to IEC 60068-2-31</p>
Internal cleaning	<ul style="list-style-type: none"> ▪ CIP cleaning ▪ SIP cleaning
Mechanical load	<p>Transmitter housing and sensor connection housing:</p> <ul style="list-style-type: none"> ▪ Protect against mechanical effects, such as shock or impact ▪ Do not use as a ladder or climbing aid

Electromagnetic compatibility (EMC)

- As per IEC/EN 61326 and NAMUR Recommendation 21 (NE 21)
 - As per IEC/EN 61000-6-2 and IEC/EN 61000-6-4
 - Device version with PROFIBUS DP: Complies with emission limits for industry as per EN 50170 Volume 2, IEC 61784
- i** The following applies for PROFIBUS DP: If baud rates > 1.5 MBaud, an EMC cable entry must be used and the cable shield must continue as far as the terminal wherever possible.
- i** Details are provided in the Declaration of Conformity.
- i** This unit is not intended for use in residential environments and cannot guarantee adequate protection of the radio reception in such environments.

Process

Medium temperature range -20 to +150 °C (-4 to +302 °F)

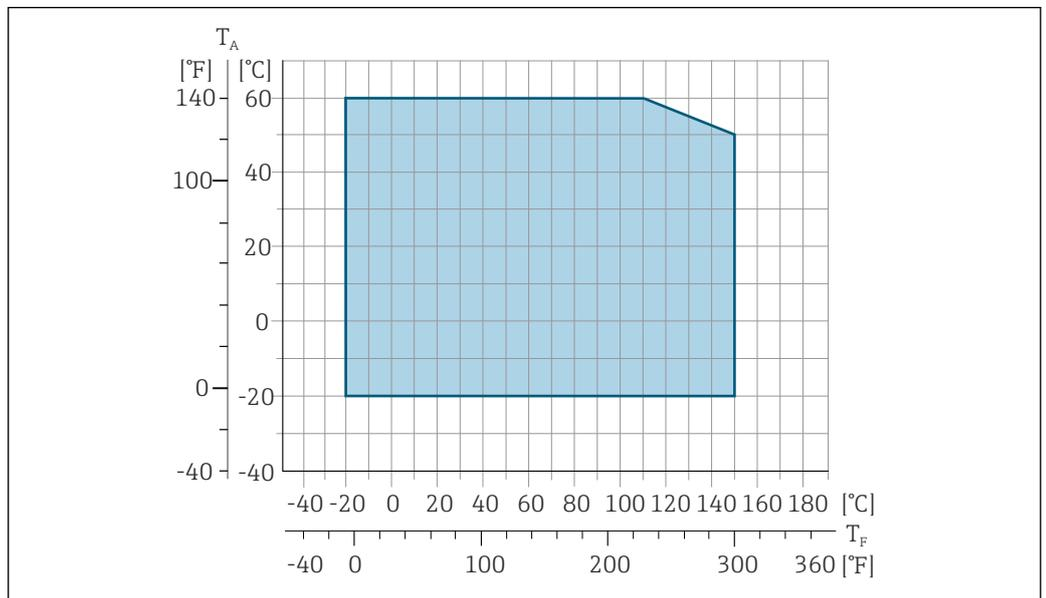

34 Promag 500 – digital
 T_A Ambient temperature range
 T_F Fluid temperature

A0027806

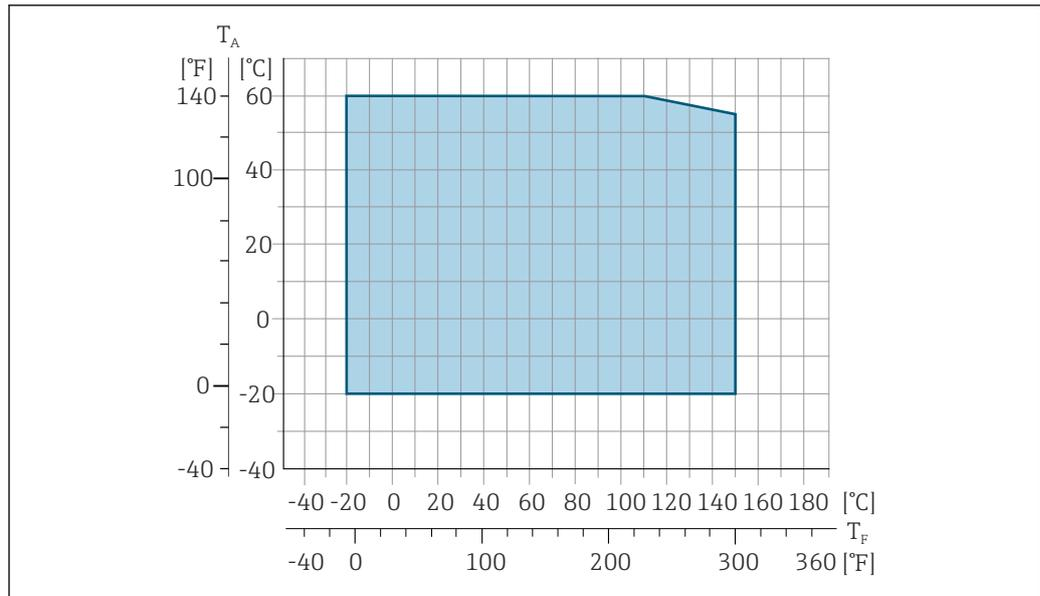

A0027450

35 Promag 500

T_A Ambient temperature range

T_F Fluid temperature

i The permitted fluid temperature in custody transfer is 0 to +50 °C (+32 to +122 °F).

Conductivity

≥5 μS/cm for liquids in general.

i Proline 500

The necessary minimum conductivity also depends on the length of the connecting cable
→ 62.

Pressure/temperature ratings

The following graphics contain material load diagrams (reference curves) for different process connections in relation to the medium temperature.

Process connections with O-ring seal, DN 2 to 25 (1/12 to 1")

Process connection: welding nipple similar to DIN EN ISO 1127, ISO 2037; coupling similar to ISO 228/DIN 2999, NPT

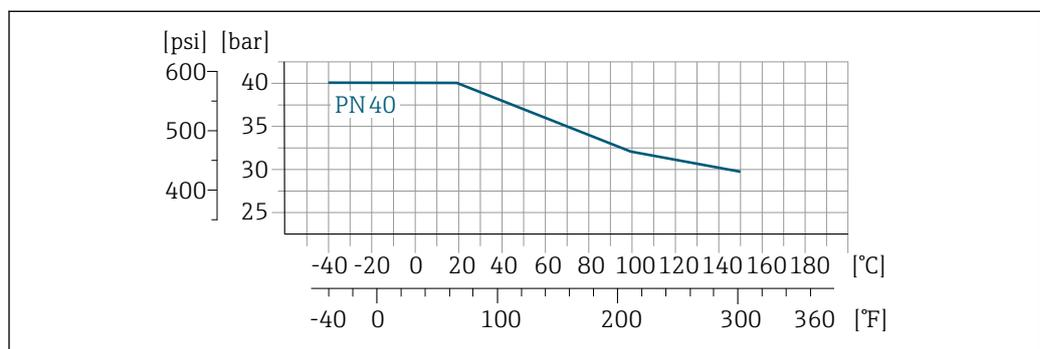

A0028928-EN

36 Process connection material: stainless steel, 1.4404 (F316L)

Process connection: flange similar to EN 1092-1 (DIN 2501), adhesive fitting

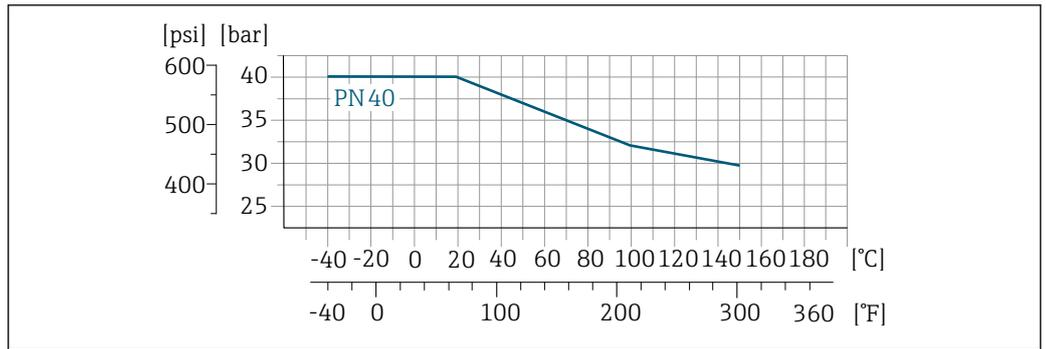

37 Process connection material: stainless steel, 1.4404 (F316L)

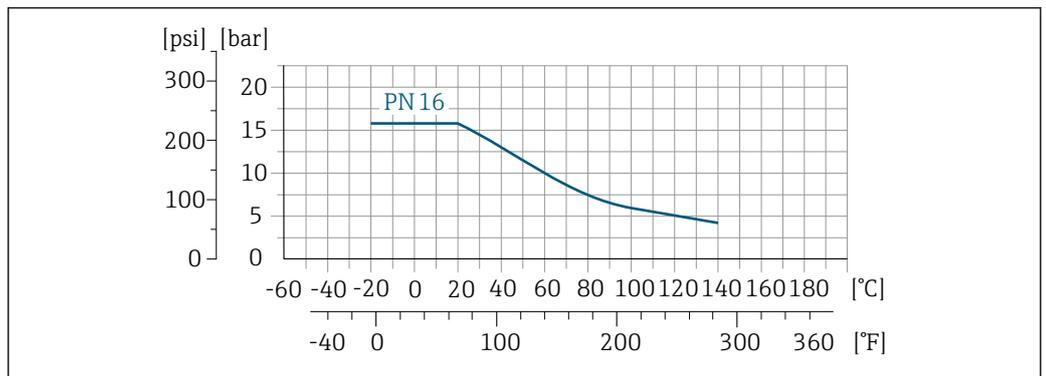

38 Process connection material: PVDF

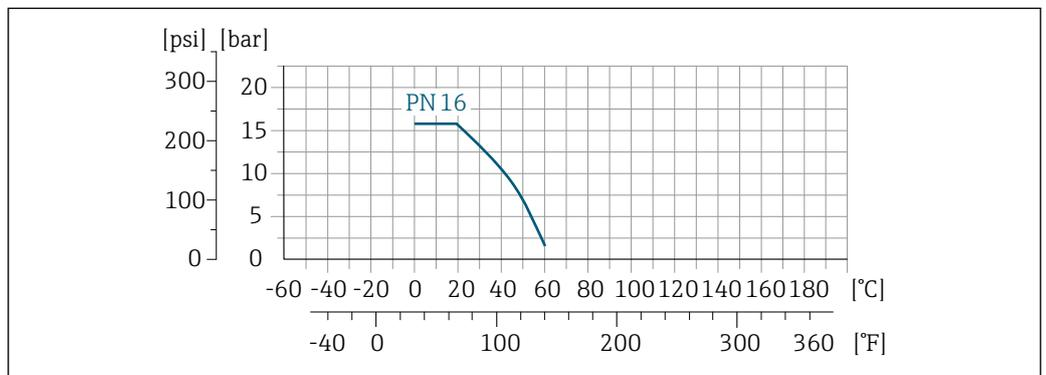

39 Process connection material: PVC-U

Process connection: flange similar to ASME B16.5

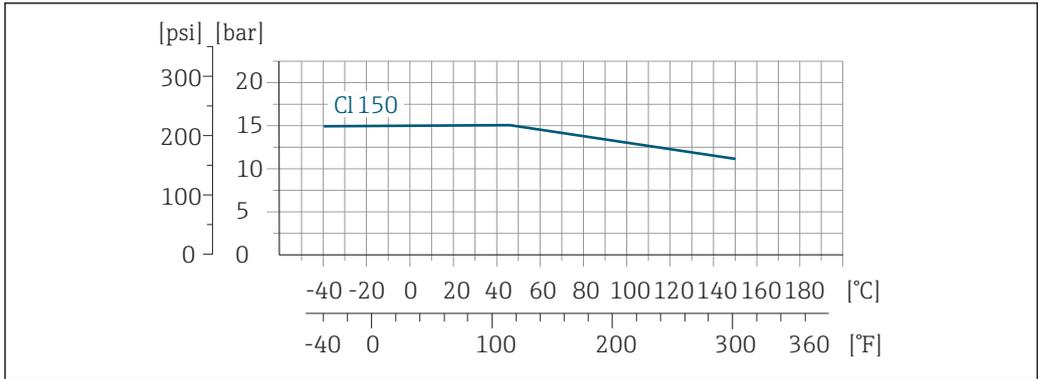

A0028936-EN

40 Process connection material: stainless steel, 1.4404 (F316L)

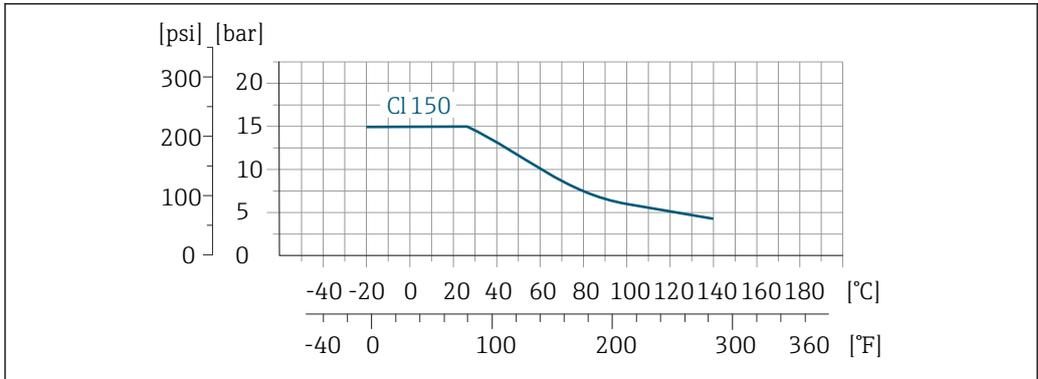

A0028937-EN

41 Process connection material: PVDF

Process connection: flange similar to JIS B2220

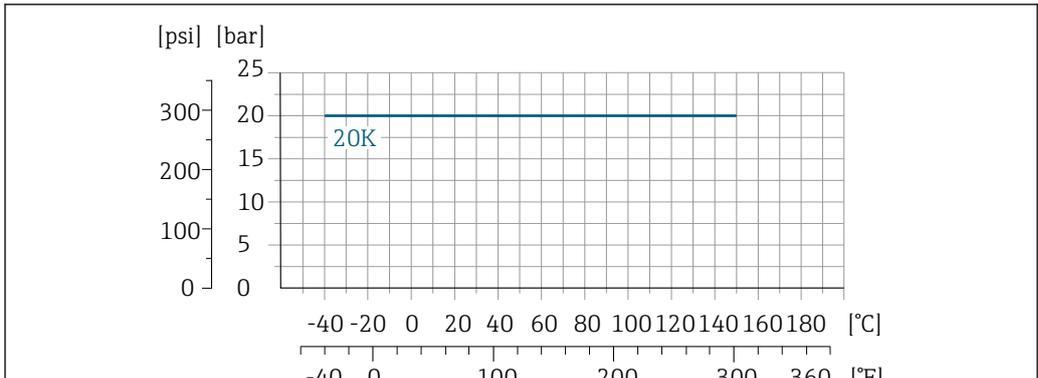

A0028938-EN

42 Process connection material: stainless steel, 1.4404 (F316L)

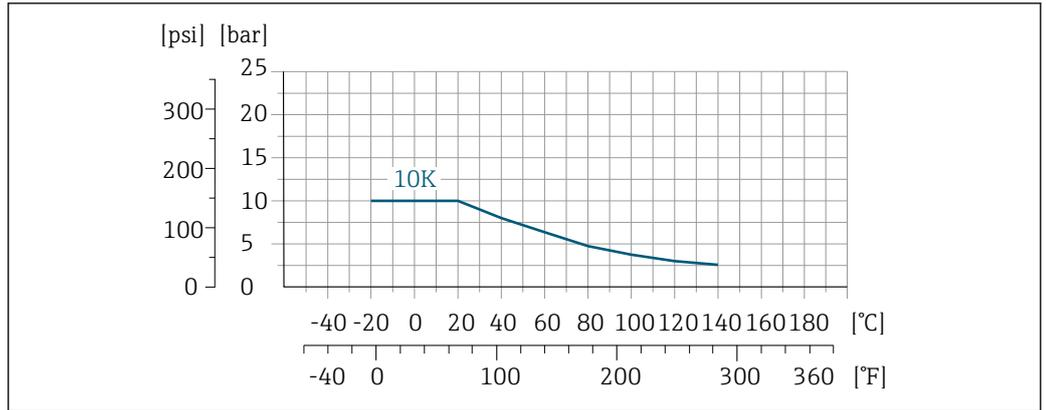

43 Process connection material: PVDF

Process connections with aseptic gasket seal, DN 2 to 25 (1/12 to 1")

Process connection: welding nipple similar to EN 10357, ASME BPE, ISO 2037; clamp similar to ISO 2852, DIN 32676; coupling similar to DIN 11851, DIN 11864-1, SMS 1145; flange similar to DIN 11864-2

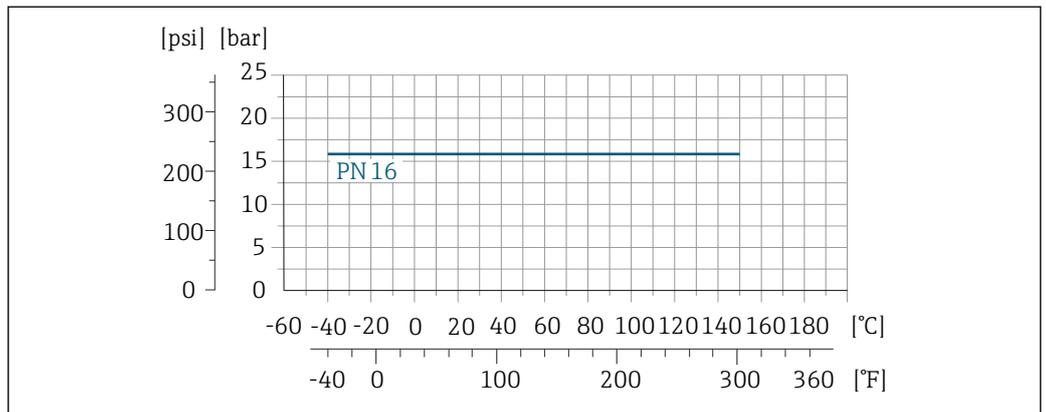

44 Process connection material: stainless steel, 1.4404 (F316L)

Process connections with aseptic gasket seal, DN 40 to 150 (1 1/2 to 6")

Process connection: coupling similar to SMS 1145

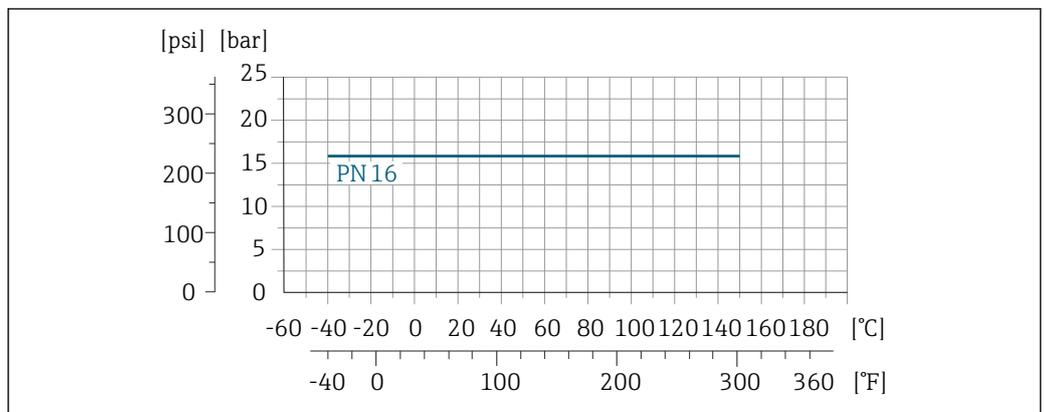

45 Process connection material: stainless steel, 1.4404 (F316L)

Process connection: welding nipple similar to EN 10357; coupling similar to DIN 11851

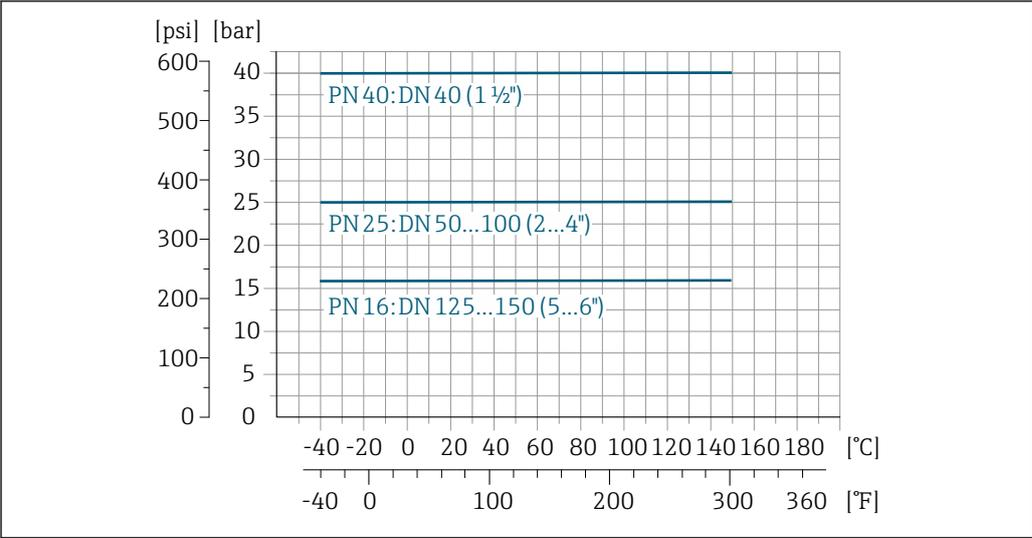

46 Process connection material: stainless steel, 1.4404 (F316L)

Process connection: welding nipple similar to ASME BPE

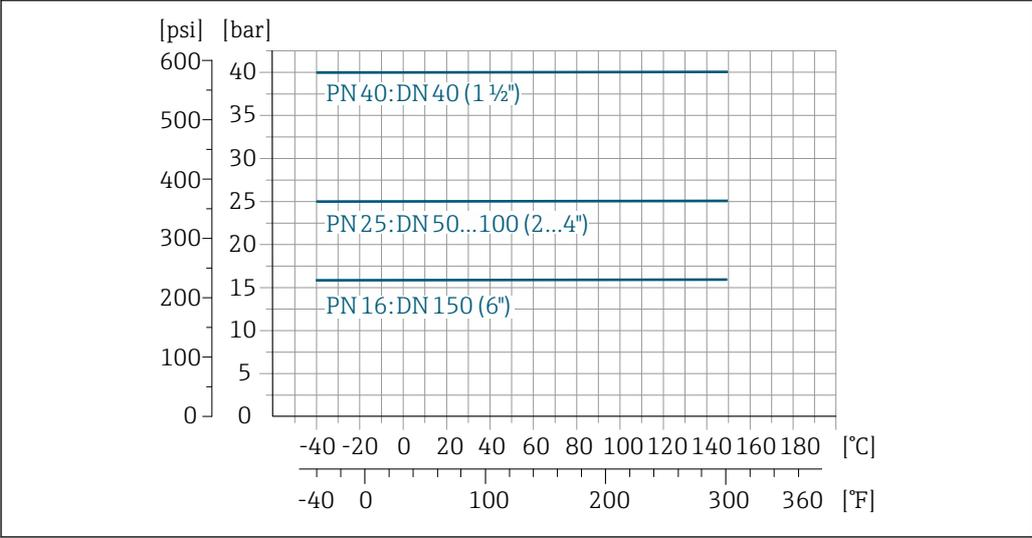

A0028942-EN

Process connection: welding nipple similar to ISO 2037

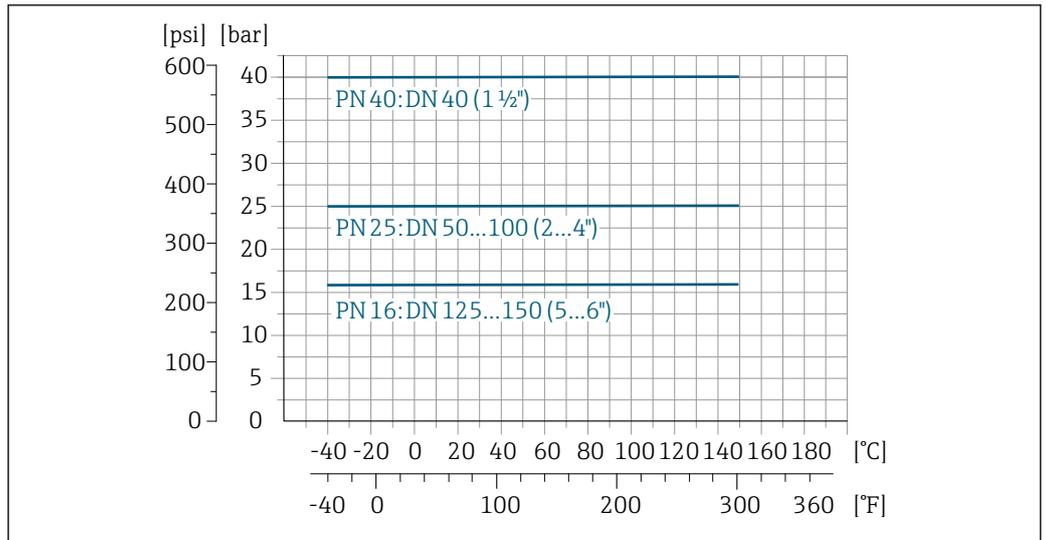

47 Process connection material: stainless steel, 1.4404 (F316L)

Process connection: clamp similar to ISO 2852, DIN 32676

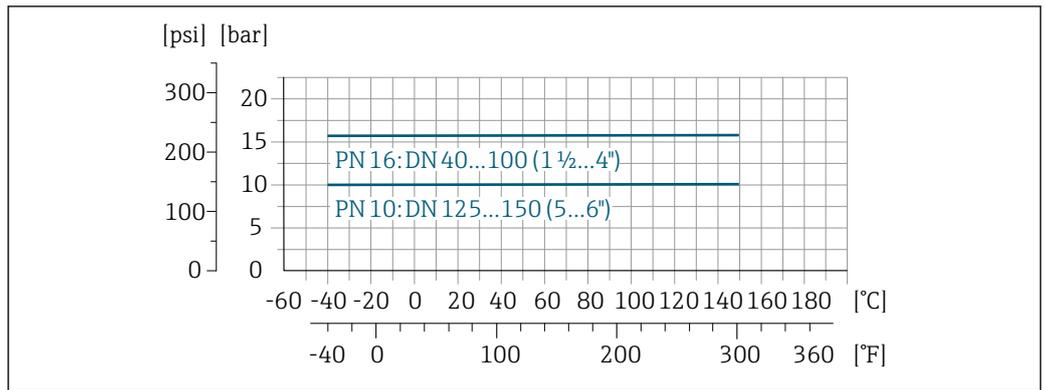

48 Process connection material: stainless steel, 1.4404 (F316L)

Process connection: coupling similar to DIN 11864-1, ISO 2853

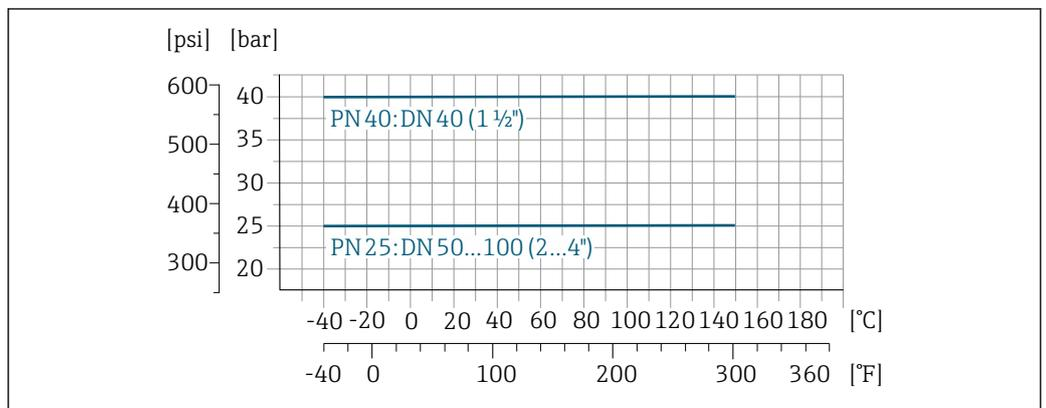

49 Process connection material: stainless steel, 1.4404 (F316L)

Process connection: flange similar to DIN 11864-2

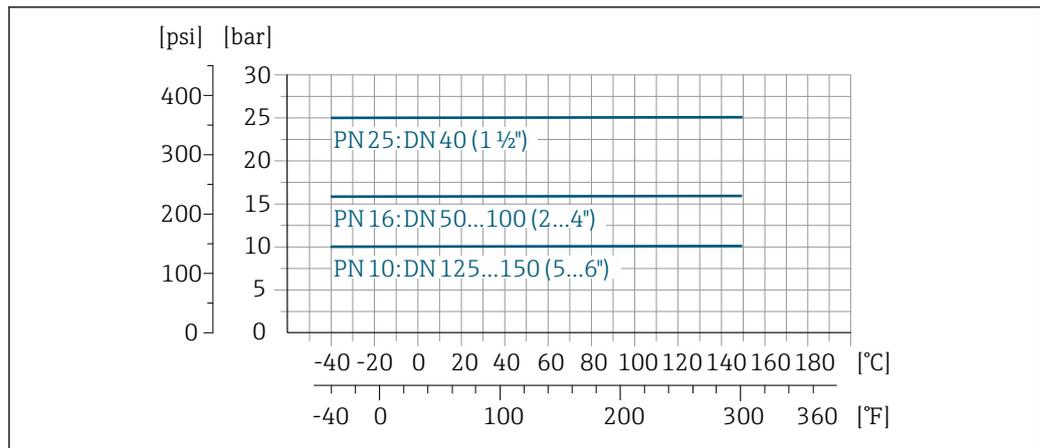

A0028945-EN

50 Process connection material: stainless steel, 1.4404 (F316L)

Pressure tightness

Liner: PFA

Nominal diameter		Limit values for absolute pressure in [mbar] ([psi]) for medium temperatures:				
[mm]	[in]	+25 °C (+77 °F)	+80 °C (+176 °F)	+100 °C (+212 °F)	+130 °C (+266 °F)	+150 °C (+302 °F)
2 to 150	1/12 to 6	0 (0)	0 (0)	0 (0)	0 (0)	0 (0)

Flow limit

The diameter of the pipe and the flow rate determine the nominal diameter of the sensor. The optimum velocity of flow is between 2 to 3 m/s (6.56 to 9.84 ft/s). Also match the velocity of flow (v) to the physical properties of the medium:

- $v < 2$ m/s (6.56 ft/s): for low conductivity values
- $v > 2$ m/s (6.56 ft/s): for media producing buildup (e.g. milk with a high fat content)
- i ▪ A necessary increase in the flow velocity can be achieved by reducing the sensor nominal diameter.
 - In the case of media with a high solids content, a sensor with a nominal diameter $> \text{DN } 8$ (3/8") can improve the signal stability and cleanability due to the larger electrodes.

Pressure loss

- No pressure loss occurs as of nominal diameter DN 8 (5/16") if the sensor is installed in a pipe with the same nominal diameter.
- Pressure losses for configurations incorporating adapters according to DIN EN 545 → 61

System pressure

Installation near pumps → 59

Vibrations

Installation in event of pipe vibrations → 59

Magnetism and static electricity

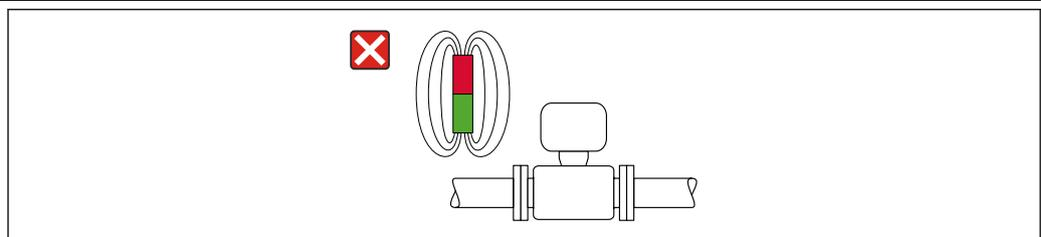

A0042152

51 Avoid magnetic fields

Mechanical construction

Dimensions in SI units

Housing of Proline 500 – digital transmitter

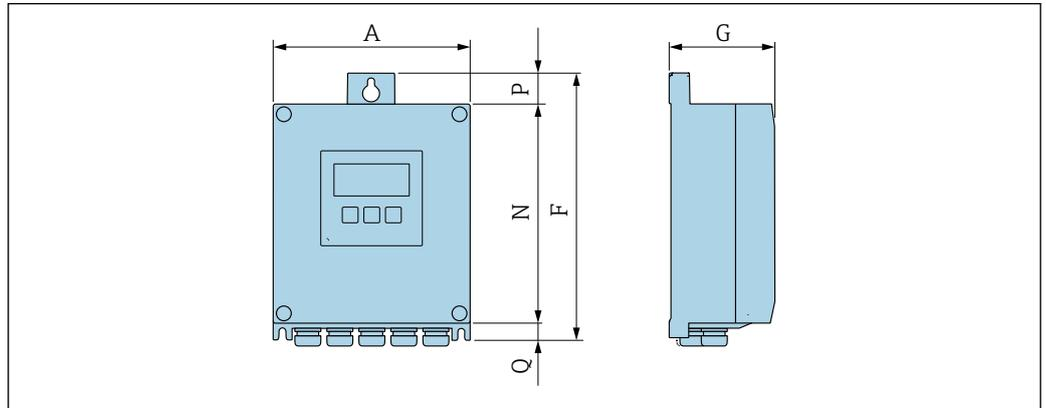

A0033789

Order code for "Transmitter housing", option A "Aluminum, coated" and order code for "Integrated ISEM electronics", option A "Sensor"

A [mm]	F [mm]	G [mm]	N [mm]	P [mm]	Q [mm]
167	232	89	187	24	21

Order code for "Transmitter housing", option D "Polycarbonate" and order code for "Integrated ISEM electronics", option A "Sensor"

A [mm]	F [mm]	G [mm]	N [mm]	P [mm]	Q [mm]
177	234	89	197	17	22

Housing of Proline 500 transmitter

Hazardous area: Zone 2; Class I, Division 2 or Zone 1; Class I, Division 1

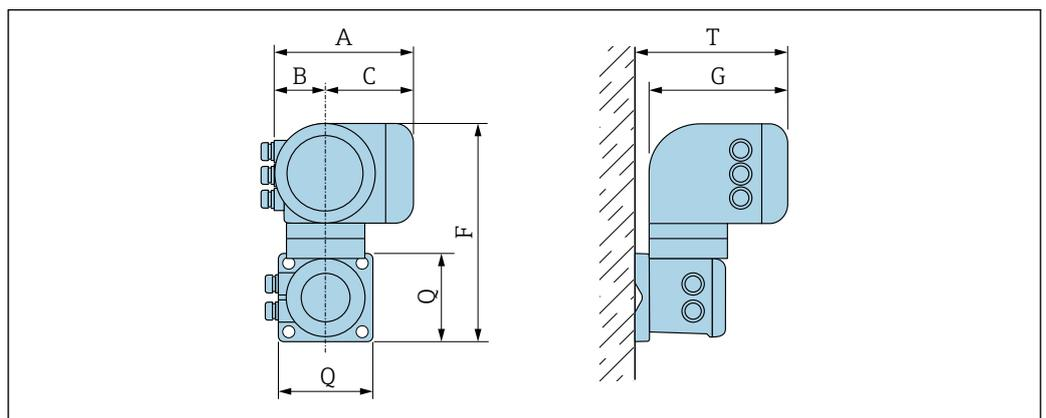

A0033788

Order code for "Transmitter housing", option A "Aluminum, coated" and order code for "Integrated ISEM electronics", option B "Transmitter"

A [mm]	B [mm]	C [mm]	F [mm]	G [mm]	Q [mm]	T [mm]
188	85	103	318	217	130	239

Sensor connection housing

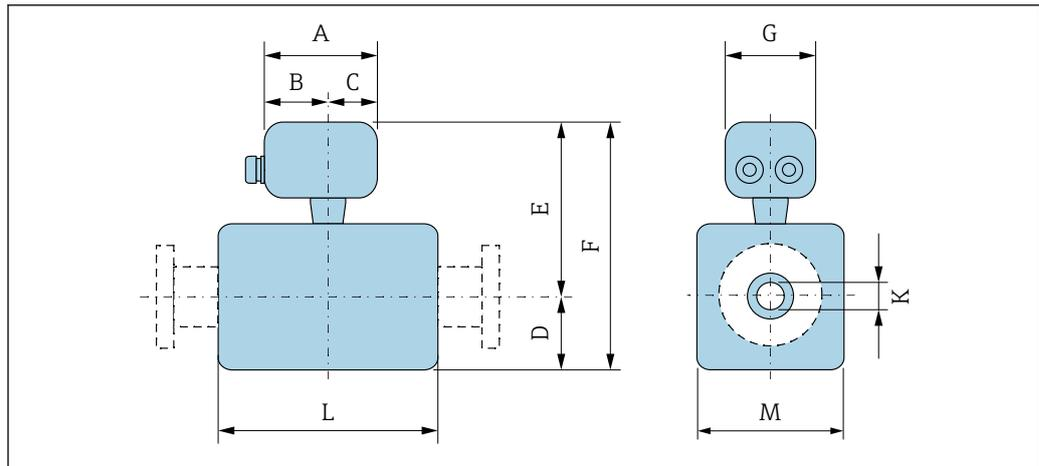

A0035761

Order code for "Sensor connection housing", option A "Aluminum, coated"

DN [mm]	A [mm]	B [mm]	C [mm]	D [mm]	E [mm]	F [mm]	G [mm]	K [mm]	L ¹⁾ [mm]	M [mm]
2	148	94	54	55	178	233	136	2.25	86	43
4	148	94	54	55	178	233	136	4.50	86	43
8	148	94	54	55	178	233	136	9.00	86	43
15	148	94	54	55	178	233	136	16.0	86	43
25	148	94	54	55	178	233	136	22.6	86	56
40	148	94	54	54	178	232	136	34.8	140	107
50	148	94	54	60	184	244	136	47.5	140	120
65	148	94	54	68	195	263	136	60.2	140	135
80	148	94	54	74	198	272	136	72.9	140	148
100	148	94	54	87	212	299	136	97.4	140	174
125	148	94	54	103	227	330	136	120.0	200	206
150	148	94	54	117	241	358	136	146.9	200	234

1) Total installed length depends on process connections. → 79

Order code for "Sensor connection housing", option B "Stainless, hygienic"

DN [mm]	A [mm]	B [mm]	C [mm]	D [mm]	E [mm]	F [mm]	G [mm]	K [mm]	L ¹⁾ [mm]	M [mm]
2	137	78	59	55	174	229	134	2.25	86	43
4	137	78	59	55	174	229	134	4.50	86	43
8	137	78	59	55	174	229	134	9.00	86	43
15	137	78	59	55	174	229	134	16.0	86	43
25	137	78	59	55	174	229	134	22.6	86	56
40	137	78	59	54	173	226	134	34.8	140	107
50	137	78	59	60	180	240	134	47.5	140	120
65	137	78	59	68	190	258	134	60.2	140	135
80	137	78	59	74	194	267	134	72.9	140	148
100	137	78	59	87	207	294	134	97.4	140	174

DN [mm]	A [mm]	B [mm]	C [mm]	D [mm]	E [mm]	F [mm]	G [mm]	K [mm]	L ¹⁾ [mm]	M [mm]
125	137	78	59	103	223	325	134	120.0	200	206
150	137	78	59	117	237	353	134	146.9	200	234

1) Total installed length depends on process connections. → 79

Order code for "Sensor connection housing", option C "Ultra-compact hygienic, stainless"

DN [mm]	A [mm]	B [mm]	C [mm]	D [mm]	E [mm]	F [mm]	G [mm]	K [mm]	L ¹⁾ [mm]	M [mm]
2	124	68	56	55	173	228	112	2.25	86	43
4	124	68	56	55	173	228	112	4.50	86	43
8	124	68	56	55	173	228	112	9.00	86	43
15	124	68	56	55	173	228	112	16.0	86	43
25	124	68	56	55	174	229	112	22.6	86	56
40	124	68	56	54	173	227	112	34.8	140	107
50	124	68	56	60	179	239	112	47.5	140	120
65	124	68	56	68	190	258	112	60.2	140	135
80	124	68	56	74	193	267	112	72.9	140	148
100	124	68	56	87	207	294	112	97.4	140	174
125	124	68	56	103	222	325	112	120.0	200	206
150	124	68	56	117	236	353	112	146.9	200	234

1) Total installed length depends on process connections. → 79

Sensor flange connection

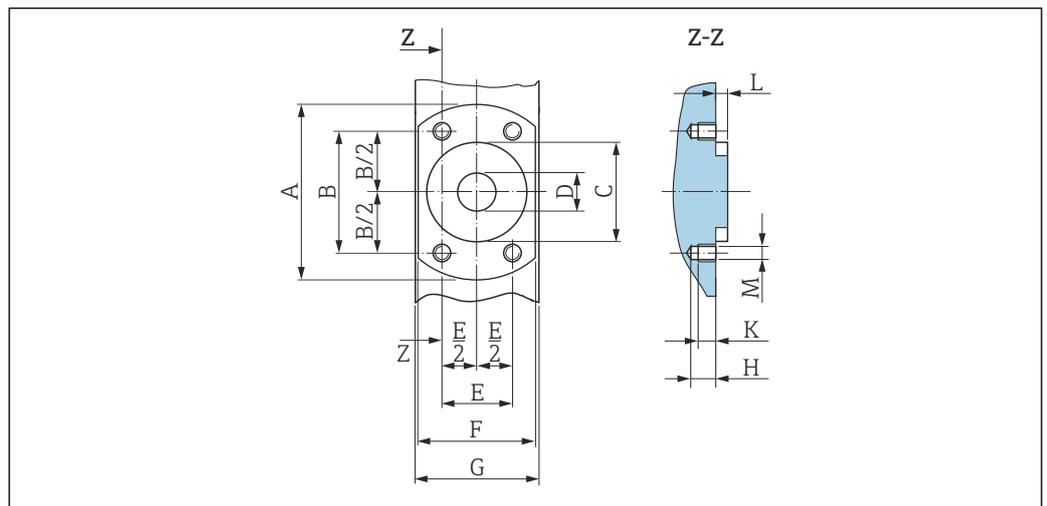

A0017657

52 Front view without process connections

DN [mm]	A [mm]	B [mm]	C [mm]	D [mm]	E [mm]	F [mm]	G [mm]	H [mm]	K [mm]	L [mm]	M [mm]
2	62	41.6	34	9	24	42	43	8.5	6	4	M6
4	62	41.6	34	9	24	42	43	8.5	6	4	M6

DN	A	B	C	D	E	F	G	H	K	L	M
[mm]	[mm]	[mm]	[mm]	[mm]	[mm]	[mm]	[mm]	[mm]	[mm]	[mm]	[mm]
8	62	41.6	34	9	24	42	43	8.5	6	4	M6
15	62	41.6	34	16	24	42	43	8.5	6	4	M6
25	72	50.2	44	26	29	55	56	8.5	6	4	M6

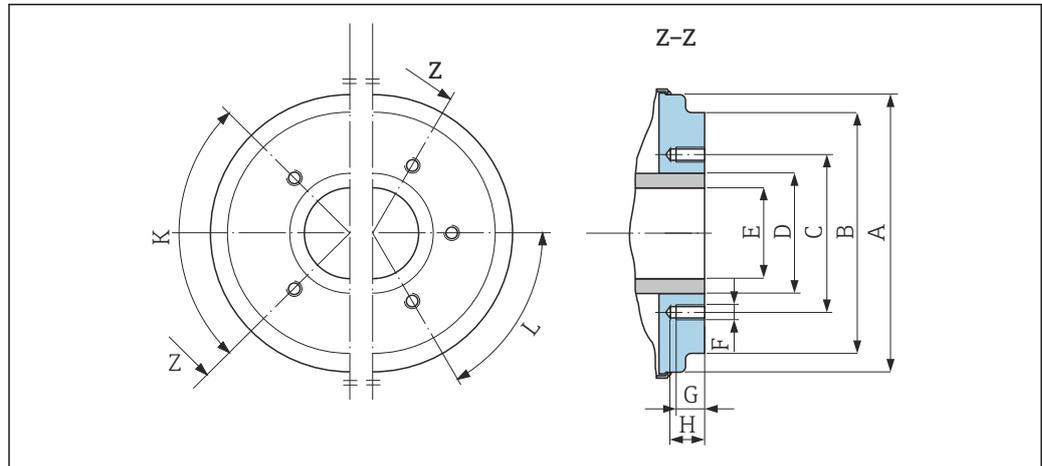

A0005528

53 Front view without process connections

DN	A	B	C	D	E	F	G	H	K	L
[mm]	[mm]	[mm]	[mm]	[mm]	[mm]	[mm]	[mm]	[mm]	90° ±0.5°	60° ±0.5°
									Tapped holes	
40	99.7	85.8	71.0	48.3	34.8	M8	12	17	4	-
50	112.7	98.8	83.5	60.3	47.5	M8	12	17	4	-
65	127.7	114.8	100.0	76.1	60.2	M8	12	17	-	6
80	140.7	133.5	114.0	88.9	72.9	M8	12	17	-	6
100	166.7	159.5	141.0	114.3	97.4	M8	12	17	-	6
125	198.7	191.5	171.0	139.7	120.0	M10	15	20	-	6
150	226.7	219.5	200.0	168.3	146.9	M10	15	20	-	6

Flange connections

Female with aseptic gasket seal

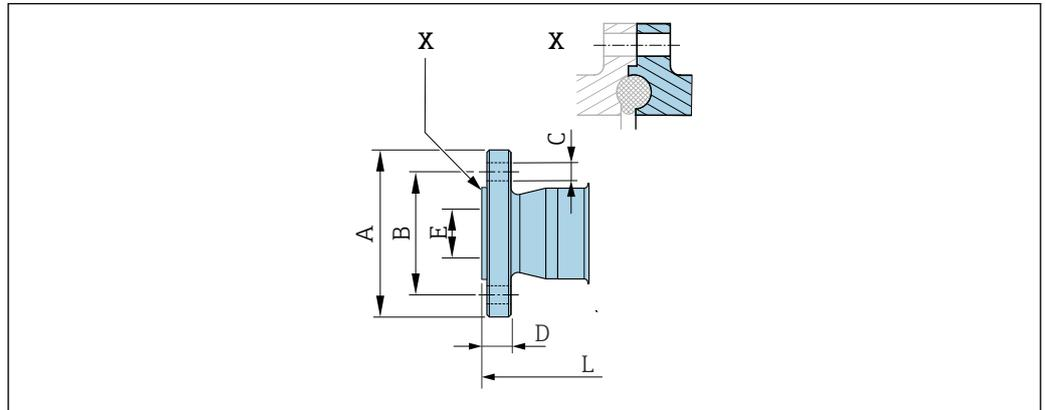

A0043232

54 Detail X: Asymmetrical process connection; the part shown in blue is provided by the supplier.

Flange DIN 11864-2, aseptic female, Form A
1.4404 (316L), suitable for pipe according to EN 10357 series A, female
Order code for "Process connection", option DES/DQS

DN [mm]	Suitable for pipe according to EN 10357 series A [mm]	A [mm]	B [mm]	C [mm]	D [mm]	E [mm]	L [mm]
2 to 8 ¹⁾	13 × 1.5 (DN 10)	54	37	4 × Ø9	10	10	183
15	19 × 1.5 (DN 15)	59	42	4 × Ø9	10	16	183
25	29 × 1.5 (DN 25)	70	53	4 × Ø9	10	26	183

Surface roughness: Ra_{max} = 0.76 µm, optional order code for "Service", option HJ: Ra_{max} = 0.38 µm electropolished
 Please note the internal diameters of the measuring pipe and process connection (E) when cleaning with pigs.

1) With DN 10 flanges as standard

Flange with notch with aseptic gasket seal

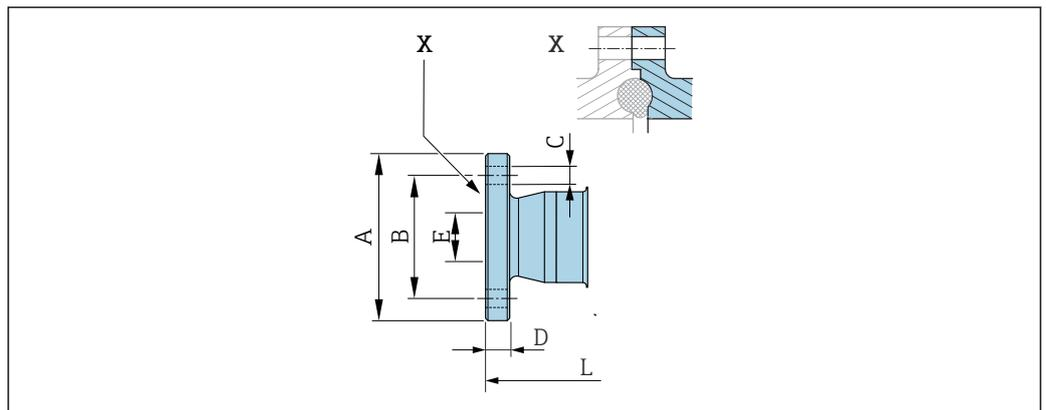

A0042819

55 Detail X: Asymmetrical process connection; the part shown in blue is provided by the supplier.

Flange DIN 11864-2, aseptic flange with notch, Form A 1.4404 (316L), suitable for pipe according to EN 10357 series A, flange with notch Order code for "Process connection", option DES/DRS							
DN [mm]	Suitable for pipe according to EN 10357 series A [mm]	A [mm]	B [mm]	C [mm]	D [mm]	E [mm]	L [mm]
40	41 × 1.5	82	65	4 × Ø9	10	38	246
50	53 × 1.5	94	77	4 × Ø9	10	50	246
65	70 × 2	113	95	8 × Ø9	10	66	246
80	85 × 2	133	112	8 × Ø11	10	81	270
100	104 × 2	159	137	8 × Ø11	10	100	278
125	129 × 2	183	161	8 × Ø11	10	125	362
150	154 × 2	213	188	8 × Ø14	10	150	362

Surface roughness: $Ra_{max} = 0.76 \mu\text{m}$, optional order code for "Service", option HJ: $Ra_{max} = 0.38 \mu\text{m}$ electropolished
Please note the internal diameters of the measuring pipe and process connection (E) when cleaning with pigs.

Flanges with O-ring seal

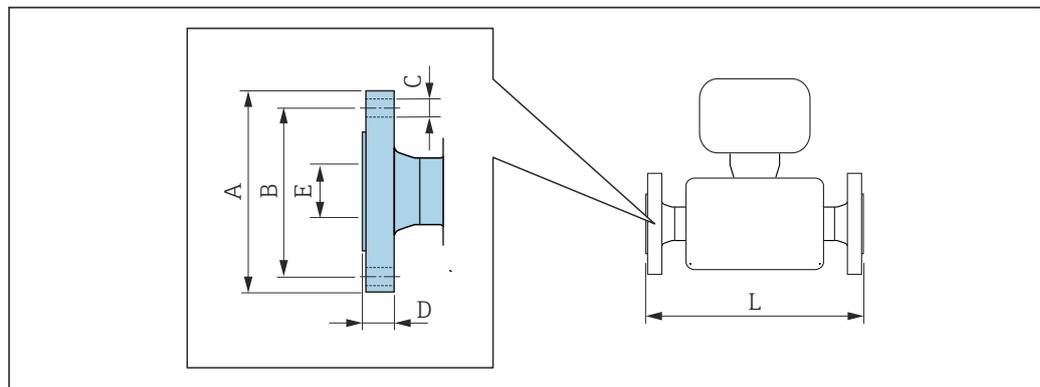

A0015621

Flange similar to EN 1092-1 (DIN 2501), Form B: PN 40 1.4404 (316L) Order code for "Process connection", option D5S						
DN [mm]	A [mm]	B [mm]	C [mm]	D [mm]	E [mm]	L [mm]
2 to 8 ¹⁾	95	65	4 × Ø14	16	17.3	198.4
15	95	65	4 × Ø14	16	17.3	198.4
25	115	85	4 × Ø14	18	28.5	198.4

Surface roughness: $Ra_{max} = 1.6 \mu\text{m}$

1) DN 2 to 8 with DN 15 flanges as standard

Flange similar to ASME B16.5: Class 150 1.4404 (316L) Order code for "Process connection", option A1S						
DN [mm]	A [mm]	B [mm]	C [mm]	D [mm]	E [mm]	L [mm]
2 to 8 ¹⁾	90	60.3	4 × Ø15.7	11.2	15.7	218
15	90	60.3	4 × Ø15.7	11.2	15.7	218

Flange similar to ASME B16.5: Class 150 1.4404 (316L) Order code for "Process connection", option A1S						
DN [mm]	A [mm]	B [mm]	C [mm]	D [mm]	E [mm]	L [mm]
25	110	79.4	4 × Ø15.7	14.2	26.7	230

Surface roughness: Ra_{max} = 1.6 µm

1) DN 2 to 8 with DN 15 flanges as standard

Flange similar to JIS/t20615, 20 K 1.4404 (316L) Order code for "Process connection", option N4S						
DN [mm]	A [mm]	B [mm]	C [mm]	D [mm]	E [mm]	L [mm]
2 to 8 ¹⁾	95	70	4 × Ø15	14	15	220
15	95	70	4 × Ø15	14	15	220
25	125	90	4 × Ø19	16	25	220

Surface roughness: Ra_{max} = 1.6 µm

1) DN 2 to 8 with DN 15 flanges as standard

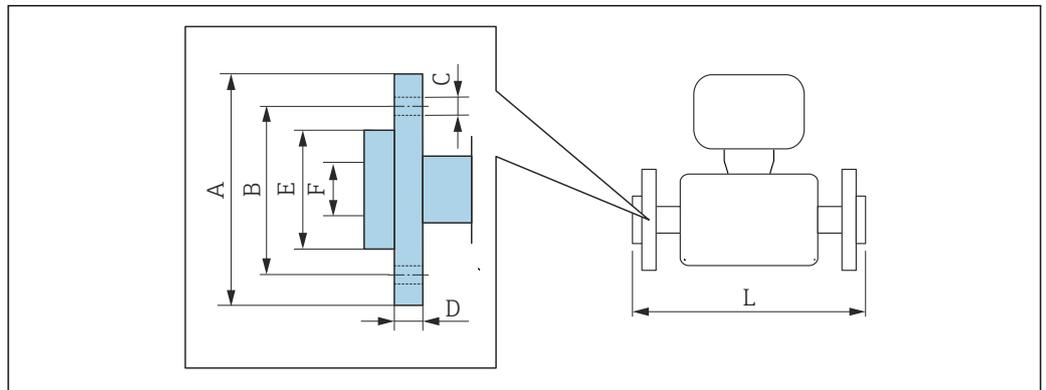

A002221

Lap joint flange similar to EN 1092-1 (DIN 2501): PN 16 PVDF Order code for "Process connection", option D3P							
DN [mm]	A [mm]	B [mm]	C [mm]	D [mm]	E [mm]	F [mm]	L [mm]
2 to 8 ¹⁾	95	65	4 x Ø14	14.5	45	17.3	200
15	95	65	4 x Ø14	14.5	45	17.3	200
25	115	85	4 x Ø14	16.5	68	28.5	200

Surface roughness: Ra_{max} = 1.6 µm
The required grounding rings can be ordered as accessories (order code: DK5HR-****).

1) DN 2 to 8 with DN 15 flanges as standard

Lap joint flange with grounding electrode similar to EN 1092-1 (DIN 2501): PN 16							
PVDF							
<i>Order code for "Process connection", option D4P</i>							
DN [mm]	A [mm]	B [mm]	C [mm]	D [mm]	E [mm]	F [mm]	L [mm]
2 to 8 ¹⁾	95	65	4 x Ø14	14.5	45	17.3	200
15	95	65	4 x Ø14	14.5	45	17.3	200
25	115	85	4 x Ø14	16.5	68	28.5	200
Surface roughness: Ra _{max} = 1.6 µm Grounding rings are not necessary.							

1) DN 2 to 8 with DN 15 flanges as standard

Lap joint flange similar to ASME B16.5: Class 150							
PVDF							
<i>Order code for "Process connection", option A1P</i>							
DN [mm]	A [mm]	B [mm]	C [mm]	D [mm]	E [mm]	F [mm]	L [mm]
2 to 8 ¹⁾	90	60.3	4 × Ø 15.7	15	35.1	15.7	200
15	90	60.3	4 × Ø 15.7	15	35.1	15.7	200
25	110	79.4	4 × Ø 15.7	16	50.8	26.7	200
Surface roughness: Ra _{max} = 1.6 µm The required grounding rings can be ordered as accessories (order code: DK5HR-****).							

1) DN 2 to 8 with DN 15 flanges as standard

Lap joint flange with grounding electrode similar to ASME B16.5: Class 150							
PVDF							
<i>Order code for "Process connection", option A4P</i>							
DN [mm]	A [mm]	B [mm]	C [mm]	D [mm]	E [mm]	F [mm]	L [mm]
2 to 8 ¹⁾	90	60.3	4 × Ø 15.7	15	35.1	15.7	200
15	90	60.3	4 × Ø 15.7	15	35.1	15.7	200
25	110	79.4	4 × Ø 15.7	16	50.8	26.7	200
Surface roughness: Ra _{max} = 1.6 µm Grounding rings are not necessary.							

1) DN 2 to 8 with DN 15 flanges as standard

Lap joint flange similar to JIS B2220: 10K							
PVDF							
<i>Order code for "Process connection", option N3P</i>							
DN [mm]	A [mm]	B [mm]	C [mm]	D [mm]	E [mm]	F [mm]	L [mm]
2 to 8 ¹⁾	95	70	4 × Ø 15.7	15	35.1	15	200
15	95	70	4 × Ø 15.7	15	35.1	15	200
25	125	90	4 × Ø 15.7	16	50.8	19	200
Surface roughness: Ra _{max} = 1.6 µm The required grounding rings can be ordered as accessories (order code: DK5HR-****).							

1) DN 2 to 8 with DN 15 flanges as standard

Lap joint flange with grounding electrode similar to JIS B2220: 10K PVDF							
<i>Order code for "Process connection", option N4P</i>							
DN [mm]	A [mm]	B [mm]	C [mm]	D [mm]	E [mm]	F [mm]	L [mm]
2 to 8 ¹⁾	95	70	4 × Ø 15.7	15	35.1	15	200
15	95	70	4 × Ø 15.7	15	35.1	15	200
25	125	90	4 × Ø 15.7	16	50.8	19	200

Surface roughness: Ra_{max} = 1.6 µm
Grounding rings are not necessary.

1) DN 2 to 8 with DN 15 flanges as standard

Welding nipple

Welding nipple with aseptic gasket seal

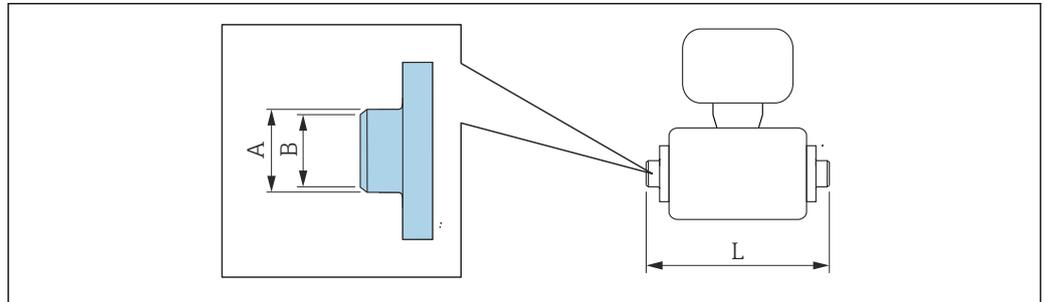

A0027510

Welding nipple according to EN 10357				
1.4404 (316L), suitable for pipe EN 10357 series A				
<i>Order code for "Process connection", option DAS</i>				
DN [mm]	Suitable for pipe EN 10357 series A [mm]	A [mm]	B [mm]	L [mm]
2 to 8	13 × 1.5	13	10	132.6
15	19 × 1.5	19	16	132.6
25	29 × 1.5	29	26	132.6
40	41 × 1.5	41	38	220
50	53 × 1.5	53	50	220
65	70 × 2	70	66	220
80	85 × 2	85	81	220
100	104 × 2	104	100	220
125	129 × 2	129	125	300
150	154 × 2	154	150	300

Surface roughness: Ra_{max} = 0.76 µm, optional order code for "Service", option HJ: Ra_{max} = 0.38 µm
electropolished
Please note the internal diameters of the measuring pipe and process connection (B) when cleaning with pigs.

Welding nipple according to ISO 2037 1.4404 (316L), suitable for pipe ISO 2037 Order code for "Process connection", option IAS				
DN [mm]	Suitable for pipe ISO 2037 [mm]	A [mm]	B [mm]	L [mm]
2 to 8	12.7 × 1.65	12	10	118.2
15	19.05 × 1.65	18	16	118.2
25	25.4 × 1.60	25	22.6	118.2
40	38 × 1.2	38	35.6	220
50	51 × 1.2	51	48.6	220
65	63.5 × 1.6	63.5	60.3	220
80	76.1 × 1.6	76.1	72.9	220
100	101.6 × 2	101.6	97.6	220
125	139.7 × 2	139.7	135.7	380
150	168.3 × 2.6	168.3	163.1	380

Surface roughness: $Ra_{max} = 0.76 \mu\text{m}$, optional order code for "Service", option HJ: $Ra_{max} = 0.38 \mu\text{m}$ electropolished
Please note the internal diameters of the measuring pipe and process connection (B) when cleaning with pigs.

Welding nipple according to ASME BPE 1.4404 (316L), suitable for pipe according to ASME BPE and DIN 11866 series C Order code for "Process connection", option AAS				
DN [mm]	Suitable for pipe according to ASME BPE [mm]	A [mm]	B [mm]	L [mm]
2 to 8	12.7 × 1.65	12.7	9	118.2
15	19.1 × 1.65	19.1	16	118.2
25	25.4 × 1.65	25.4	22.6	118.2
40	38.1 × 1.65	38.1	34.8	220
50	50.8 × 1.65	50.8	47.5	220
65	63.5 × 1.65	63.5	60.2	220
80	76.2 × 1.65	76.2	72.9	220
100	101.6 × 1.65	101.6	97.4	220
150	152.4 × 2.77	152.4	146.9	300

Surface roughness: $Ra_{max} = 0.76 \mu\text{m}$, optional order code for "Service", option HJ: $Ra_{max} = 0.38 \mu\text{m}$ electropolished
Please note the internal diameters of the measuring pipe and process connection (B) when cleaning with pigs.

Welding nipple with O-ring seal

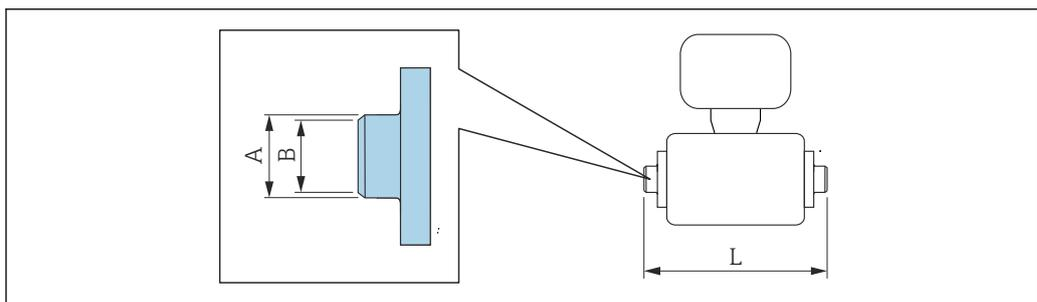

A0027510

Welding nipple according to ISO 1127
1.4404 (316L), suitable for pipe according to ISO 1127 series 1
Order code for "Process connection", option A2S

DN [mm]	Suitable for pipe according to ISO 1127 series 1 [mm]	A [mm]	B [mm]	L [mm]
2 to 8	13.5 × 2.30	13.5	9	126.6
15	21.3 × 2.65	21.3	16	126.6
25	33.7 × 3.25	33.7	27.2	126.6

Surface roughness: Ra_{max} = 1.6 µm

Welding nipple according to ISO 1127
1.4404 (316L), suitable for pipe according to ISO 1127 series 1 and DIN 11866 series B
Order code for "Process connection", option D1S

DN [mm]	Suitable for pipe according to ISO 1127 series 1 and DIN 11866 series B [mm]	A [mm]	B [mm]	L [mm]
2 to 8	13.5 × 1.6	13.5	10.3	126.6
15	21.3 × 1.6	21.3	18.1	126.6
25	33.7 × 2.0	33.7	29.7	126.6

Surface roughness: Ra_{max} = 1.6 µm

Welding nipple according to ISO 2037
1.4404 (316L), suitable for pipe ISO 203
Order code for "Process connection", option I1S

DN [mm]	Suitable for pipe ISO 2037 [mm]	A [mm]	B [mm]	L [mm]
2 to 8	13.5 × 2.3	13.5	9	126.6
15	21.3 × 2.65	21.3	16	126.6
25	33.7 × 3.25	33.7	27.2	126.6

Surface roughness: Ra_{max} = 1.6 µm

Clamp connections

Clamp connections with aseptic gasket seal

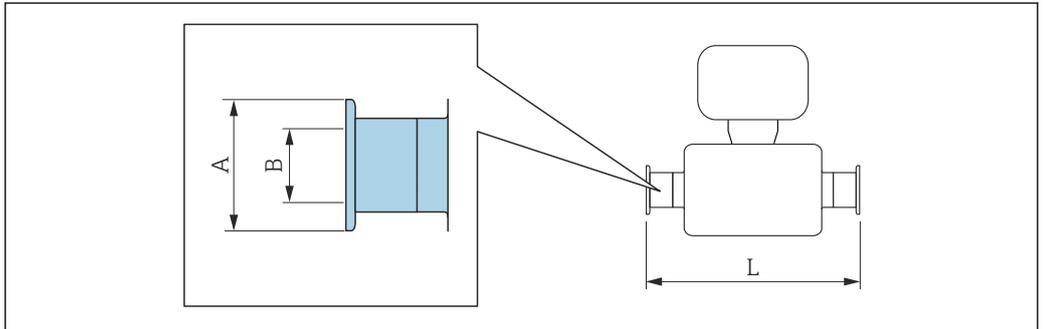

A0015625

Clamp according to DIN 32676 1.4404 (316L)				
<i>Order code for "Process connection", option DBS</i>				
DN [mm]	Suitable for pipe [mm]	A [mm]	B [mm]	L [mm]
2 to 8	14 × 2 (DN 10)	34	10	168
15	20 × 2 (DN 15)	34	16	168
25	30 × 2 (DN 25)	50.5	26	175
40	41 × 1.5	50.5	38	220
50	53 × 1.5	64	50	220
65	70 × 2	91	66	220
80	85 × 2	106	81	220
100	104 × 2	119	100	220
125	129 × 2	155	125	300
150	154 × 2	183	150	300

Surface roughness: $Ra_{max} = 0.76 \mu\text{m}$, optional order code for "Service", option HJ: $Ra_{max} = 0.38 \mu\text{m}$ electropolished
Please note the internal diameters of the measuring pipe and process connection (B) when cleaning with pigs.

Tri-Clamp 1.4404 (316L), suitable for pipe according to ASME BPE and DIN 11866 series C				
<i>Order code for "Process connection", option FAS</i>				
DN [mm]	Suitable for pipe according to ASME BPE [mm]	A [mm]	B [mm]	L [mm]
2 to 8	12.7 × 1.65	25	9.4	143
15	19.1 × 1.65	25	15.8	143
25	25.4 × 1.65	50.4	22.1	143
40	38.1 × 1.65	50.4	34.8	220
50	50.8 × 1.65	63.9	47.5	220
65	63.5 × 1.65	77.4	60.2	220
80	76.2 × 1.65	90.9	72.9	220
100	101.6 × 2.11	118.9	97.4	220
150	152.4 × 2.77	166.9	146.9	300

Surface roughness: $Ra_{max} = 0.76 \mu\text{m}$, optional order code for "Service", option HJ: $Ra_{max} = 0.38 \mu\text{m}$ electropolished
Please note the internal diameters of the measuring pipe and process connection (B) when cleaning with pigs.

Clamp according to ISO 2852, Fig. 2 1.4404 (316L)				
<i>Order code for "Process connection", option IBS</i>				
DN [mm]	Suitable for pipe ISO 2037 [mm]	A [mm]	B [mm]	L [mm]
25	24.5 × 1.65	50.5	22.6	174.6
40	38 × 1.6	50.5	35.6	220
50	51 × 1.6	64	48.6	220
65	63.5 × 1.6	77.5	60.3	220
80	76.1 × 1.6	91	72.9	220
100	101.6 × 2	119	97.6	220

**Clamp according to ISO 2852, Fig. 2
1.4404 (316L)**
Order code for "Process connection", option IBS

DN [mm]	Suitable for pipe ISO 2037 [mm]	A [mm]	B [mm]	L [mm]
125	139.7 × 2	155	135.7	300
150	168.3 × 2.6	183	163.1	300

Surface roughness: Ra_{max} = 0.76 µm, optional order code for "Service", option HJ: Ra_{max} = 0.38 µm electropolished
Please note the internal diameters of the measuring pipe and process connection (B) when cleaning with pigs.

Couplings

Thread with aseptic gasket seal

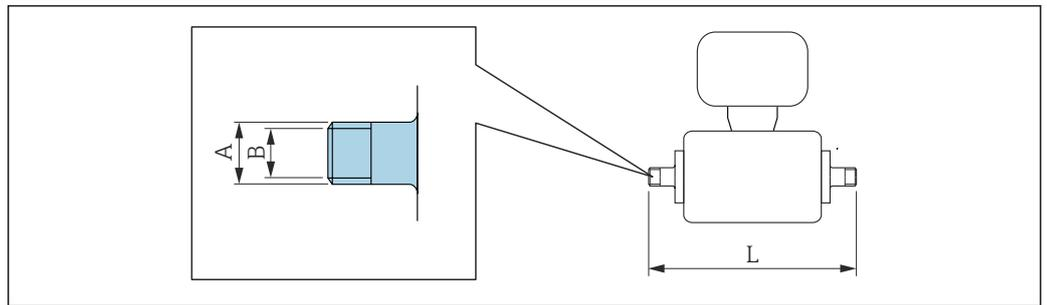

A0027509

**Coupling DIN 11851, thread
1.4404 (316L), suitable for pipe EN 10357 series B**
Order code for "Process connection", option DCS

DN [mm]	Suitable for pipe EN 10357 series B [mm]	A [mm]	B [mm]	L [mm]
2 to 8	12 × 1 (DN 10)	Rd 28 × 1/8	10	174
15	18 × 1.5	Rd 34 × 1/8	16	174
25	28 × 1 or 28×1.5	Rd 52 × 1/6	26	190

Surface roughness: Ra_{max} = 0.76 µm, optional order code for "Service", option HJ: Ra_{max} = 0.38 µm electropolished
Please note the internal diameters of the measuring pipe and process connection (B) when cleaning with pigs.

**Coupling DIN 11851, thread
1.4404 (316L), suitable for pipe EN 10357 series A**
Order code for "Process connection", option DCS

DN [mm]	Suitable for pipe EN 10357 series A [mm]	A [mm]	B [mm]	L [mm]
40	41 × 1.5	Rd 65 × 1/6	38	260
50	53 × 1.5	Rd 78 × 1/6	50	260
65	70 × 2	Rd 95 × 1/6	66	270
80	85 × 2	Rd 110 × 1/4	81	280
100	104 × 2	Rd 130 × 1/4	100	290
125	129 × 2	Rd 160 × 1/4	125	380
150	154 × 2	Rd 160 × 1/4	150	390

Surface roughness: Ra_{max} = 0.76 µm, optional order code for "Service", option HJ: Ra_{max} = 0.38 µm electropolished
Please note the internal diameters of the measuring pipe and process connection (B) when cleaning with pigs.

Coupling DIN 11864-1, aseptic thread, Form A 1.4404 (316L), suitable for pipe EN 10357 series A <i>Order code for "Process connection", option DDS</i>					
DN [mm]	Suitable for pipe EN 10357 series A [mm]	A [mm/in]	B [mm]	L [mm]	
2 to 8	13 × 1.5 (DN 10)	Rd 28 × 1/8	10	170	
15	19 × 1.5	Rd 34 × 1/8	16	170	
25	29 × 1.5	Rd 52 × 1/6	26	184	
40	41 × 1.5	Rd 65 × 1/6	38	256	
50	53 × 1.5	Rd 78 × 1/6	50	256	
65	70 × 2	Rd 95 × 1/6	66	266	
80	85 × 2	Rd 110 × 1/4	81	276	
100	104 × 2	Rd 130 × 1/4	100	286	

Surface roughness: Ra_{max} = 0.76 µm, optional order code for "Service", option HJ: Ra_{max} = 0.38 µm electropolished
Please note the internal diameters of the measuring pipe and process connection (B) when cleaning with pigs.

Coupling ISO 2853, thread 1.4404 (316L) <i>Order code for "Process connection", option ICS</i>					
DN [mm]	Suitable for pipe ISO 2037 [mm]	DN Clamp ISO 2853 [mm]	A [mm/in]	B [mm]	L [mm]
40	38 × 1.6	38	Tr 50.5 × 3.175	35.6	256
50	51 × 1.6	51	Tr 64 × 3.175	48.6	256
65	63.5 × 1.6	63.5	Tr 77.5 × 3.175	60.3	266
80	76.1 × 1.6	76.1	Tr 91 × 3.175	72.9	276
100	101.6 × 2	101.6	Tr 118 × 3.175	97.6	286

Surface roughness: Ra_{max} = 0.76 µm, optional order code for "Service", option HJ: Ra_{max} = 0.38 µm electropolished
Please note the internal diameters of the measuring pipe and process connection (B) when cleaning with pigs.

Coupling SMS 1145, thread 1.4404 (316L) <i>Order code for "Process connection", option SAS</i>					
DN [mm]	Suitable for pipe [mm]	DN SMS 1145 [mm]	A [mm/in]	B [mm]	L [mm]
25	1	25	Rd 40 × 1/6	22.6	147.6
40	38.1 × 1.65	38	Rd 60 × 1/6	34.8	256
50	50.8 × 1.65	51	Rd 70 × 1/6	47.5	256
65	63.5 × 1.65	63.5	Rd 85 × 1/6	60.2	266
80	76.2 × 1.65	76	Rd 98 × 1/6	72.6	276
100	101.6 × 1.65	101.6	Rd 132 × 1/6	97.4	286

Surface roughness: Ra_{max} = 0.76 µm, optional order code for "Service", option HJ: Ra_{max} = 0.38 µm electropolished
Please note the internal diameters of the measuring pipe and process connection (B) when cleaning with pigs.

Thread with O-ring seal

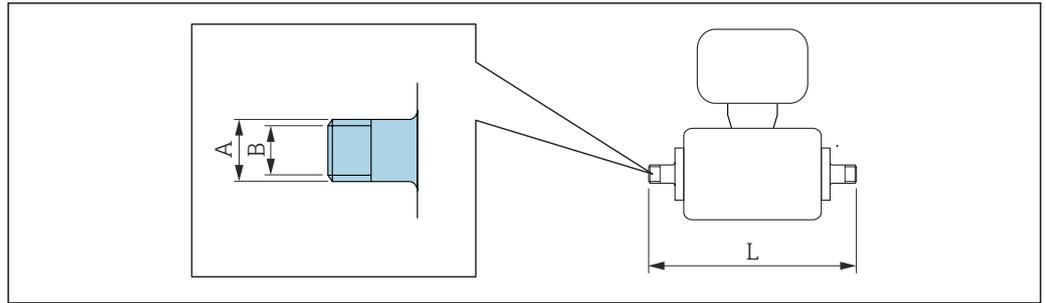

A0027509

**External thread according to ISO 228/DIN 2999
1.4404 (316L)**

Order code for "Process connection", option I2S

DN [mm]	Suitable for internal thread ISO 228/DIN 2999 [in]	A [mm/in]	B [mm]	L [mm]
2 to 8	R 3/8	R 10.1 × 3/8	10	166
15	R 1/2	R 13.2 × 1/2	16	166
25	R 1	R 16.5 × 1	25	170

Surface roughness: Ra_{max} = 1.6 μm

**Internal thread according to ISO 228/DIN 2999
1.4404 (316L)**

Order code for "Process connection", option I3S

DN [mm]	Suitable for external thread ISO 228/DIN 2999 [in]	A [mm/in]	B [mm]	L [mm]
2 to 8	Rp 3/8	Rp 13 × 3/8	9	176
15	Rp 1/2	Rp 14 × 1/2	16	176
25	Rp 1	Rp 17 × 1	27.2	188

Surface roughness: Ra_{max} = 1.6 μm

Hose adapter

Hose adapter with O-ring seal

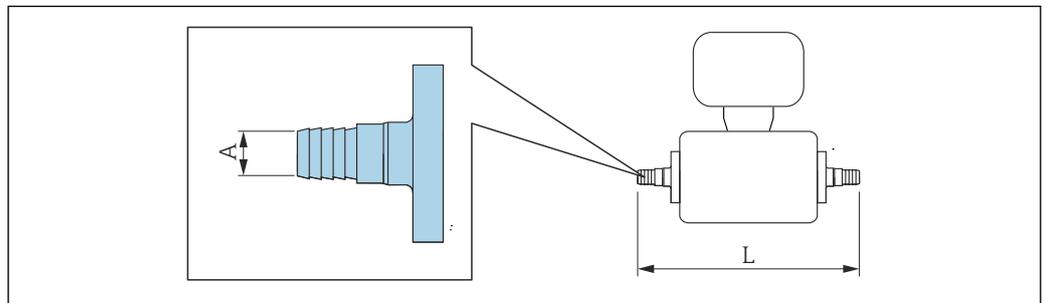

A0027511

Hose adapter 1.4404 (316L) Order code for "Process connection", options O1S, O2S, O3S			
DN [mm]	Suitable for internal diameter [mm]	A [mm]	L [mm]
2 to 8	13	10	184
15	16	12.6	184
25	19	16	184

Surface roughness: Ra_{max} = 1.6 µm

Adhesive sleeves

Adhesive sleeves with O-ring seal

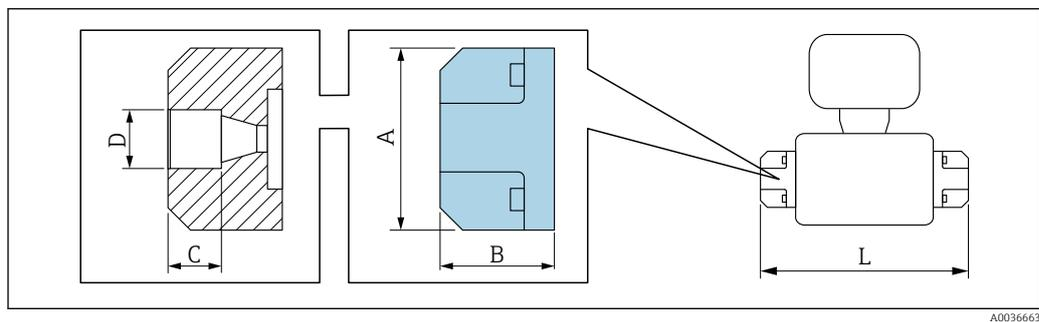

A0036663

Adhesive sleeve PVC Order code for "Process connection", option O2V						
DN [mm]	Suitable for pipe [mm] / [in]	A [mm]	B [mm]	C [mm]	D [mm]	L [mm]
2 to 8	20 × 2 (DIN 8062)	62	38.5	18	20.2	163
15			28.0			142

Surface roughness: Ra_{max} = 1.6 µm
The required grounding rings can be ordered as accessories (order code: DK5HR-****).

Mounting kits

Wall mounting kit

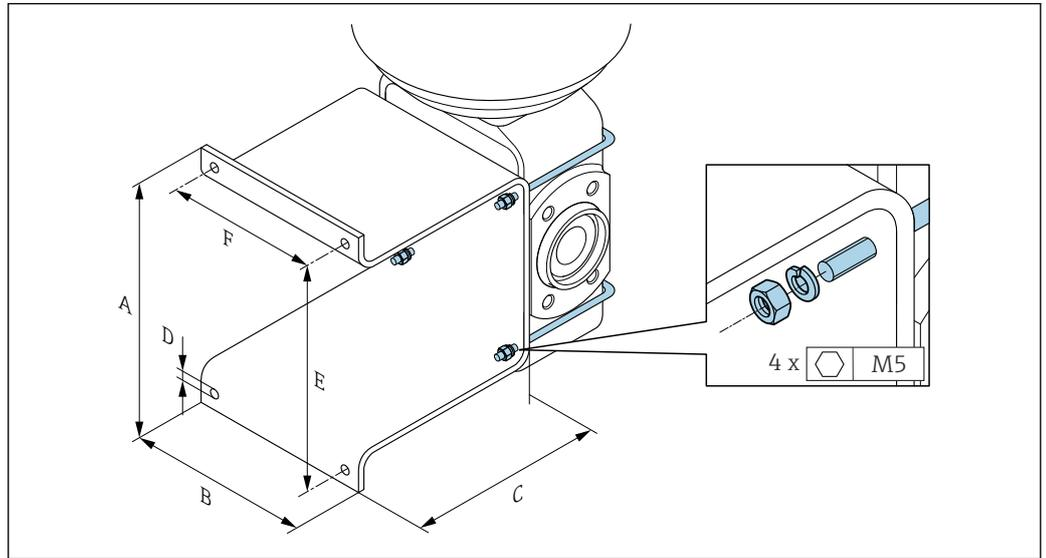

A0005537

A [mm]	B [mm]	C [mm]	Ø D [mm]	E [mm]	F [mm]
137	110	120	7	125	88

Accessories

Weather protection cover

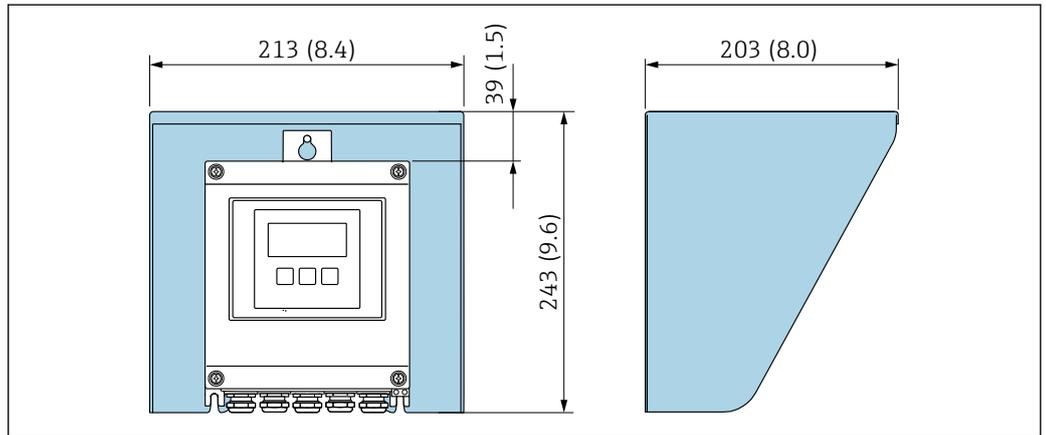

A0029552

56 Weather protection cover for Proline 500 – digital; engineering unit mm (in)

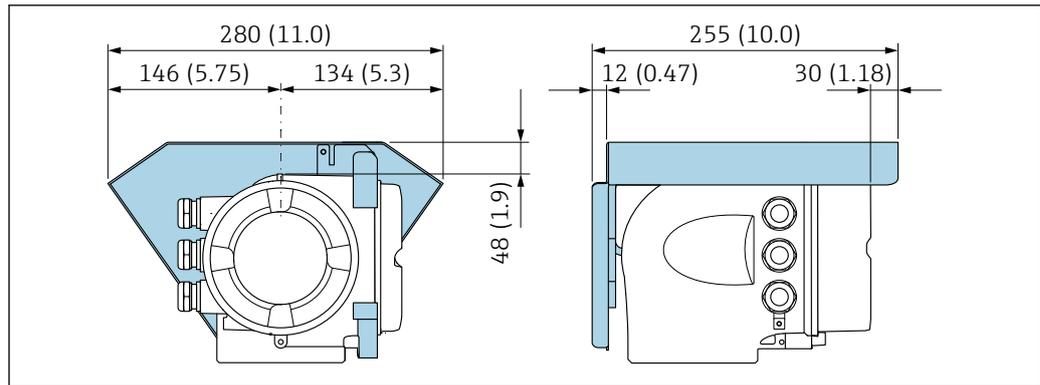

A0029553

57 Weather protection cover for Proline 500; engineering unit mm (in)

External WLAN antenna

i The external WLAN antenna is not suitable for use in hygienic applications.

Proline 500 – digital

External WLAN antenna mounted on device

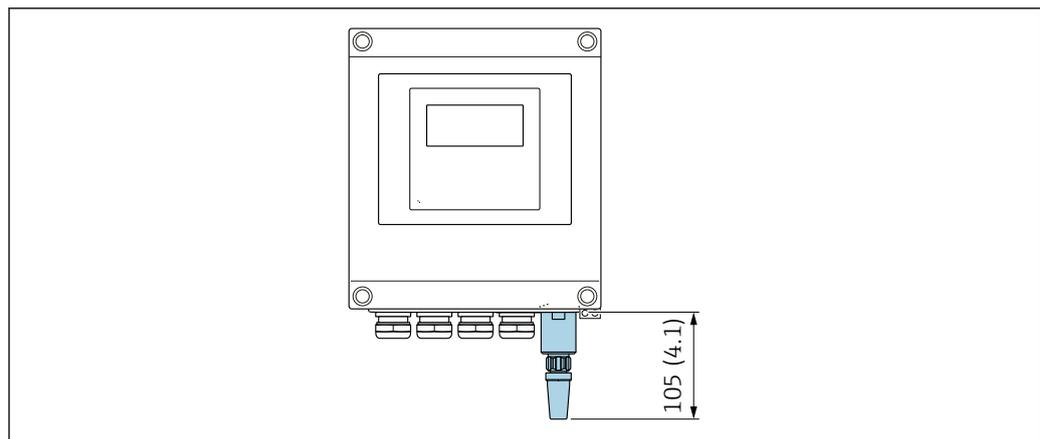

A0033607

58 Engineering unit mm (in)

External WLAN antenna mounted with cable

The external WLAN antenna can be mounted separately from the transmitter if the transmission/reception conditions at the transmitter mounting location are poor.

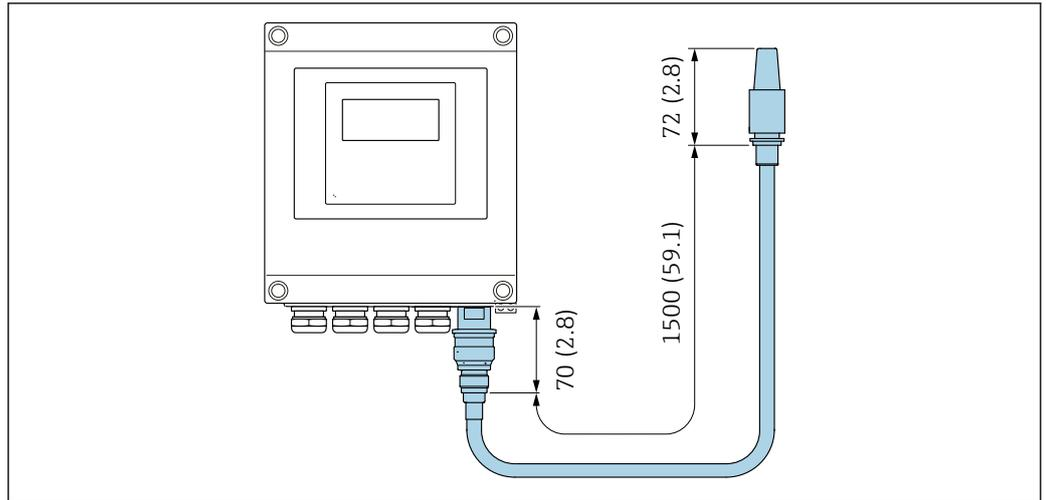

A0033606

59 Engineering unit mm (in)

Proline 500

External WLAN antenna mounted on device

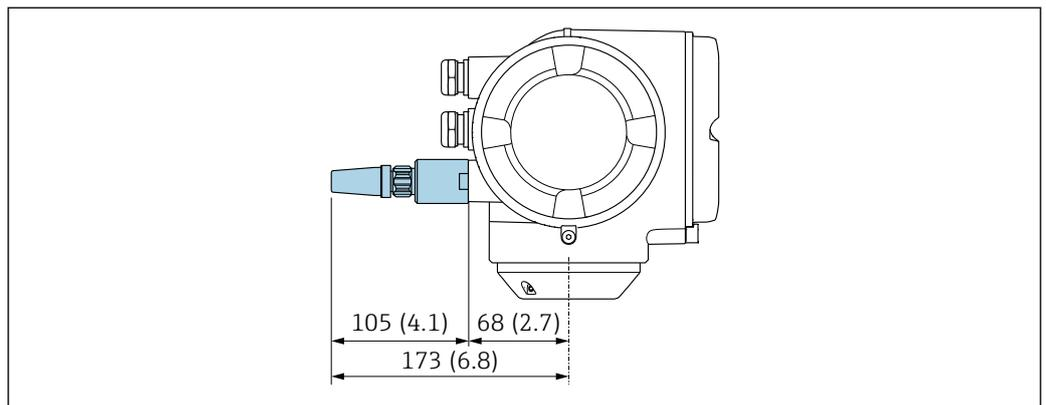

A0028923

60 Engineering unit mm (in)

External WLAN antenna mounted with cable

The external WLAN antenna can be mounted separately from the transmitter if the transmission/reception conditions at the transmitter mounting location are poor.

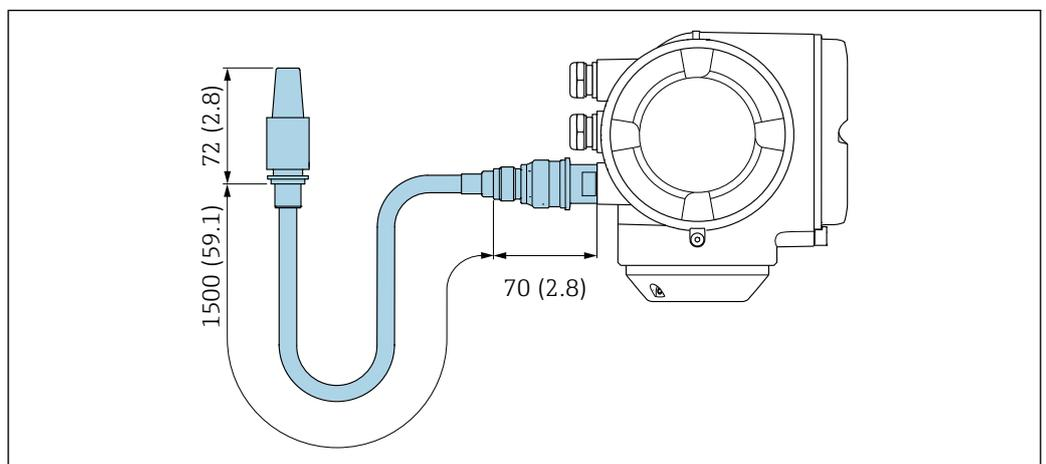

A0033597

61 Engineering unit mm (in)

Spacer

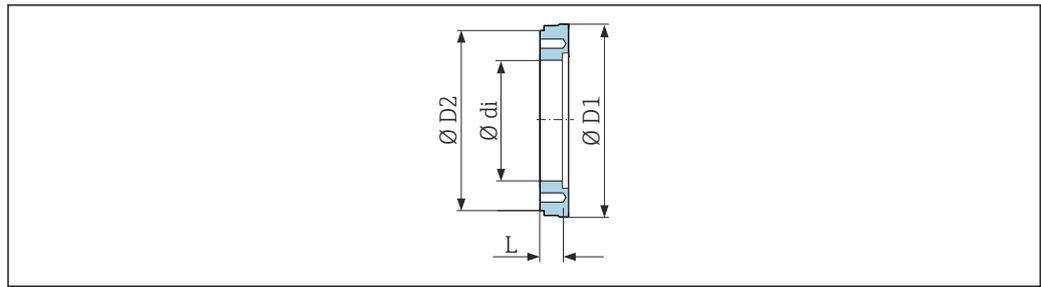

A0017294

Order code: DK5HB-****				
DN [mm]	di [mm]	D1 [mm]	D2 [mm]	L [mm]
80	72.9	140.7	141	30
100	97.4	166.7	162	30

Clamp connections with aseptic gasket seal available for order

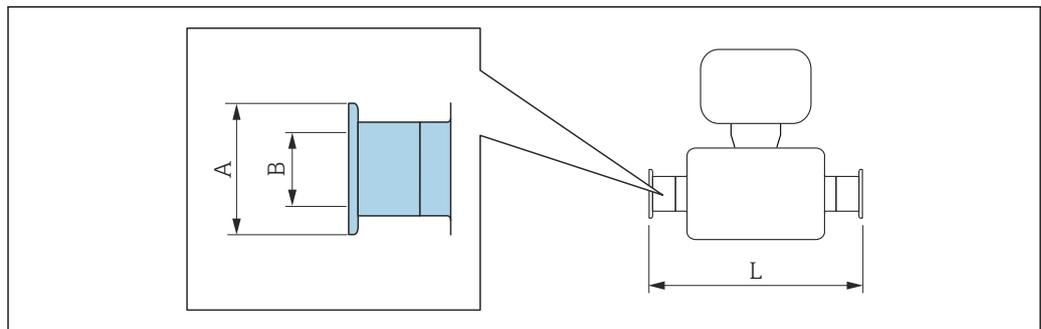

A0015625

Tri-Clamp 1.4404 (316L), suitable for pipe according to ASME BPE and BS 4825, reduction from pipe OD 1" (Tri-Clamp connection) to device DN 15 Order code: DKH**-HF**				
DN [mm]	Suitable for pipe according to ASME BPE and BS 4825 (reduction) [mm]	A [mm]	B [mm]	L [mm]
15	Pipe OD 1"	50.4	22.1	143

Surface roughness: Ra_{max} = 0.76 µm, optional order code for "Design", option CB: Ra_{max} = 0.38 µm electropolished
Please note the internal diameters of the measuring pipe and process connection (B) when cleaning with pigs.

Couplings with O-ring seal available for order

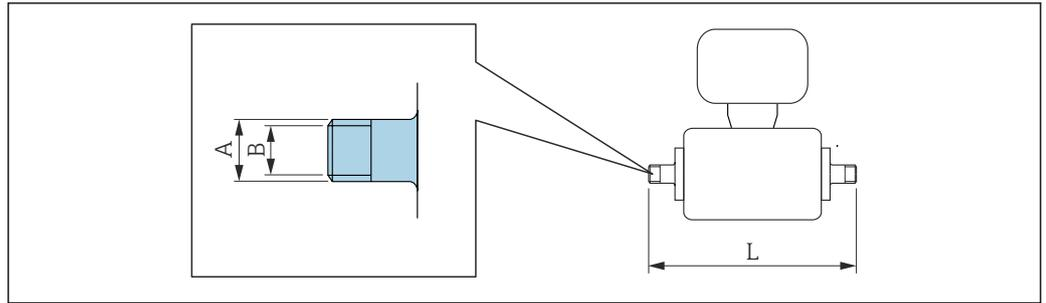

A0027509

External thread
 1.4404 (316L)
 Order code: DKH**-GD**

DN [mm]	Suitable for internal thread NPT [in]	A [mm/in]	B [mm]	L [mm]
2 to 8	NPT 3/8	R 15.5 × 3/8	10	186
15	NPT 1/2	R 20 × 1/2	16	186
25	NPT 1	R 25 × 1	25	196

Surface roughness: Ra_{max} = 1.6 μm

Internal thread
 1.4404 (316L)
 Order code: DKH**-GC**

DN [mm]	Suitable for external thread NPT [in]	A [mm/in]	B [mm]	L [mm]
2 to 8	NPT 3/8	R 13 × 3/8	8.9	176
15	NPT 1/2	R 14 × 1/2	16	176
25	NPT 1	R 17 × 1	27.2	188

Surface roughness: Ra_{max} = 1.6 μm

Grounding rings

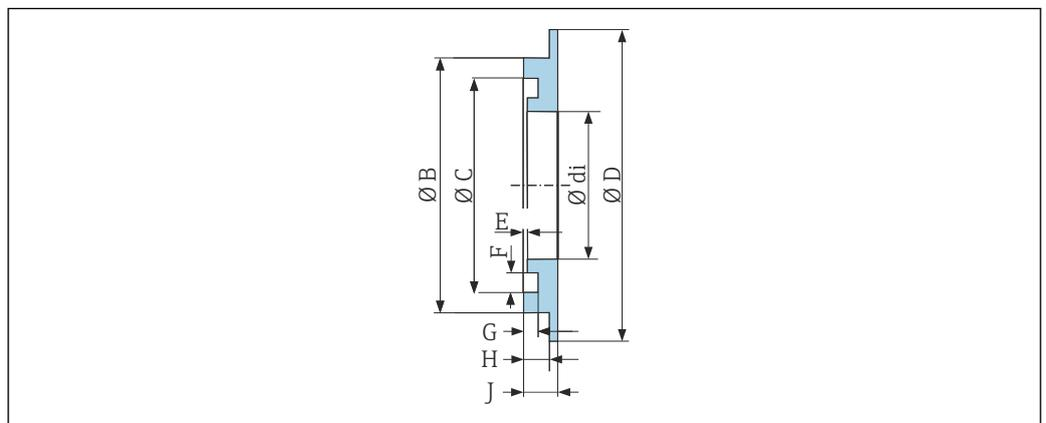

A0017673

For lap joint flange made of PVDF and PVC adhesive sleeve
 1.4435 (316L), Alloy C22, tantalum
 Order code: DK5HR-****

DN [mm]	di [mm]	B [mm]	C [mm]	D [mm]	E [mm]	F [mm]	G [mm]	H [mm]	J [mm]
2 to 8	9	22	17.6	33.9	0.5	3.5	1.9	3.4	4.5
15	16	29	24.6	33.9	0.5	3.5	1.9	3.4	4.5
25	26	39	34.6	43.9	0.5	3.5	1.9	3.4	4.5

Dimensions in US units

Housing of Proline 500 – digital transmitter

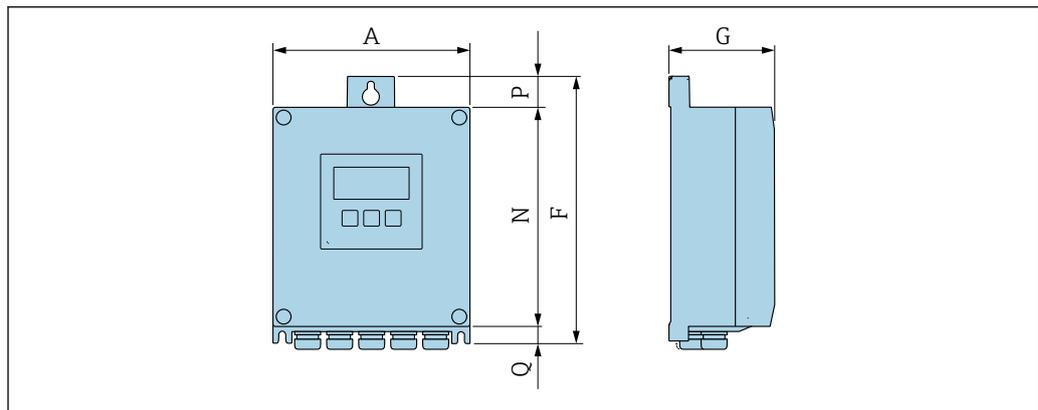

A0033789

Order code for "Transmitter housing", option A "Aluminum, coated" and order code for "Integrated ISEM electronics", option A "Sensor"

A [in]	F [in]	G [in]	N [in]	P [in]	Q [in]
6.57	9.13	3.50	7.36	0.94	0.83

Order code for "Transmitter housing", option D "Polycarbonate" and order code for "Integrated ISEM electronics", option A "Sensor"

A [in]	F [in]	G [in]	N [in]	P [in]	Q [in]
6.97	9.21	3.50	7.76	0.67	0.87

Housing of Proline 500 transmitter

Hazardous area: Zone 2; Class I, Division 2 or Zone 1; Class I, Division 1

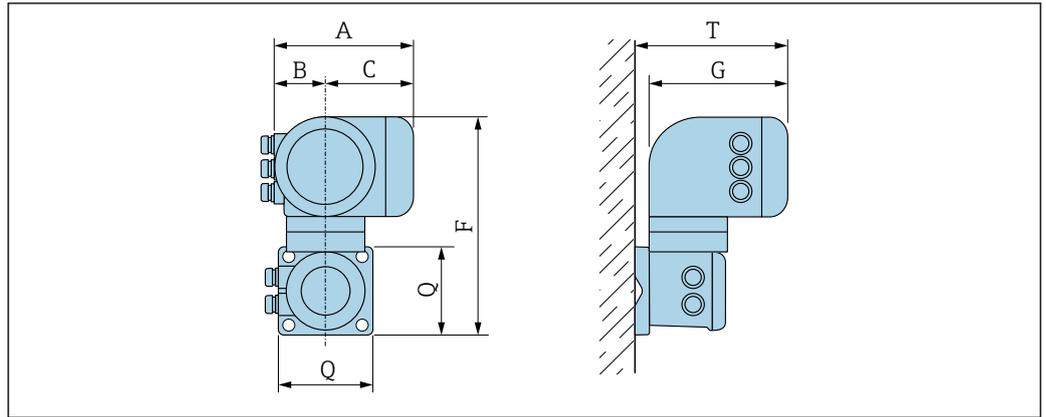

A0033788

Order code for "Transmitter housing", option A "Aluminum, coated" and order code for "Integrated ISEM electronics", option B "Transmitter"

A [in]	B [in]	C [in]	F [in]	G [in]	Q [in]	T [in]
7.40	3.35	4.06	12.5	8.54	5.12	9.41

Sensor connection housing

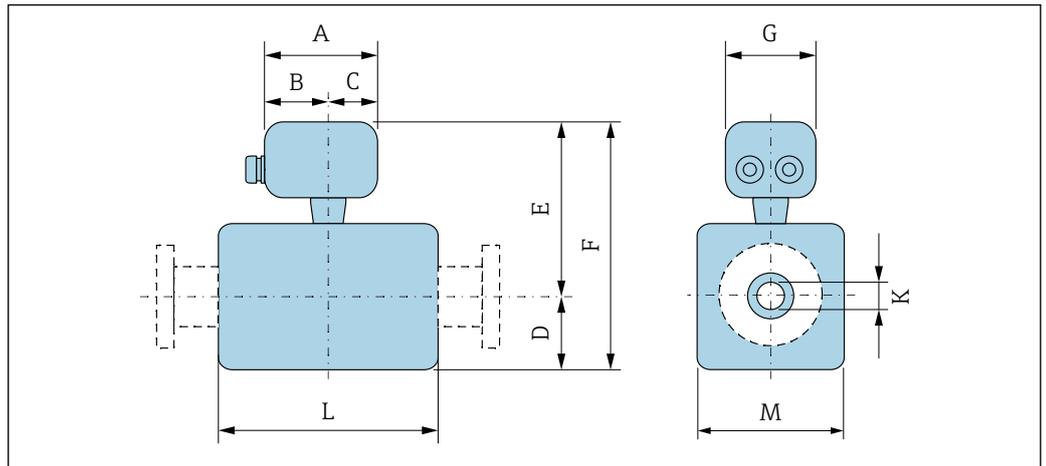

A0035761

Order code for "Sensor connection housing", option A "Aluminum, coated"

DN [in]	A [in]	B [in]	C [in]	D [in]	E [in]	F [in]	G [in]	K [in]	L ¹⁾ [in]	M [in]
1/12	5.83	3.70	2.13	2.17	7.01	9.17	5.35	0.09	3.39	1.69
1/8	5.83	3.70	2.13	2.17	7.01	9.17	5.35	0.18	3.39	1.69
3/8	5.83	3.70	2.13	2.17	7.01	9.17	5.35	0.35	3.39	1.69
1/2	5.83	3.70	2.13	2.17	7.01	9.17	5.35	0.63	3.39	1.69
1	5.83	3.70	2.13	2.17	7.01	9.17	5.35	0.89	3.39	2.20
1 1/2	5.83	3.70	2.13	2.13	7.01	9.13	5.35	1.37	5.51	4.21
2	5.83	3.70	2.13	2.36	7.24	9.61	5.35	1.87	5.51	4.72
3	5.83	3.70	2.13	2.91	7.80	10.7	5.35	2.87	5.51	5.83

DN [in]	A [in]	B [in]	C [in]	D [in]	E [in]	F [in]	G [in]	K [in]	L ¹⁾ [in]	M [in]
4	5.83	3.70	2.13	3.43	8.35	11.8	5.35	3.83	5.51	6.85
6	5.83	3.70	2.13	4.61	9.49	14.1	5.35	5.78	7.87	9.21

1) Total installed length depends on process connections. → ☰ 100

Order code for "Sensor connection housing", option B "Stainless, hygienic"

DN [in]	A [in]	B [in]	C [in]	D [in]	E [in]	F [in]	G [in]	K [in]	L ¹⁾ [in]	M [in]
$\frac{1}{12}$	5.39	3.07	2.32	2.17	6.85	9.02	5.28	0.09	3.39	1.69
$\frac{1}{8}$	5.39	3.07	2.32	2.17	6.85	9.02	5.28	0.18	3.39	1.69
$\frac{3}{8}$	5.39	3.07	2.32	2.17	6.85	9.02	5.28	0.35	3.39	1.69
$\frac{1}{2}$	5.39	3.07	2.32	2.17	6.85	9.02	5.28	0.63	3.39	1.69
1	5.39	3.07	2.32	2.17	6.85	9.02	5.28	0.89	3.39	2.20
1 ½	5.39	3.07	2.32	2.13	6.81	8.90	5.28	1.37	5.51	4.21
2	5.39	3.07	2.32	2.36	7.09	9.45	5.28	1.87	5.51	4.72
3	5.39	3.07	2.32	2.91	7.64	10.5	5.28	2.87	5.51	5.83
4	5.39	3.07	2.32	3.43	8.15	11.6	5.28	3.83	5.51	6.85
6	5.39	3.07	2.32	4.61	9.33	13.9	5.28	5.78	7.87	9.21

1) Total installed length depends on process connections. → ☰ 100

Order code for "Sensor connection housing", option C "Ultra-compact hygienic, stainless"

DN [in]	A [in]	B [in]	C [in]	D [in]	E [in]	F [in]	G [in]	K [in]	L ¹⁾ [in]	M [in]
$\frac{1}{12}$	4.88	2.68	2.20	2.17	6.81	8.98	4.41	0.09	3.39	1.69
$\frac{1}{8}$	4.88	2.68	2.20	2.17	6.81	8.98	4.41	0.18	3.39	1.69
$\frac{3}{8}$	4.88	2.68	2.20	2.17	6.81	8.98	4.41	0.35	3.39	1.69
$\frac{1}{2}$	4.88	2.68	2.20	2.17	6.81	8.98	4.41	0.63	3.39	1.69
1	4.88	2.68	2.20	2.17	6.85	9.02	4.41	0.89	3.39	2.20
1 ½	4.88	2.68	2.20	2.13	6.81	8.94	4.41	1.37	5.51	4.21
2	4.88	2.68	2.20	2.36	7.05	9.41	4.41	1.87	5.51	4.72
3	4.88	2.68	2.20	2.91	7.60	10.5	4.41	2.87	5.51	5.83
4	4.88	2.68	2.20	3.43	8.15	11.6	4.41	3.83	5.51	6.85
6	4.88	2.68	2.20	4.61	9.29	13.9	4.41	5.78	7.87	9.21

1) Total installed length depends on process connections. → ☰ 100

Sensor flange connection

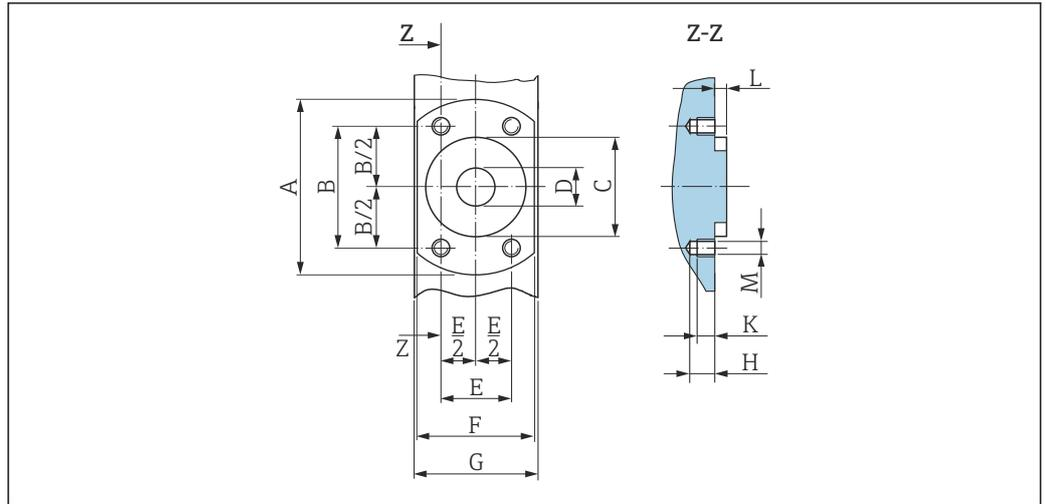

A0017657

62 Front view without process connections

DN	A	B	C	D	E	F	G	H	K	L	M
[in]	[in]	[in]	[in]	[in]	[in]	[in]	[in]	[in]	[in]	[in]	[mm]
1/12	2.44	1.64	1.34	0.35	0.94	1.65	1.69	0.33	0.24	0.16	M6
5/32	2.44	1.64	1.34	0.35	0.94	1.65	1.69	0.33	0.24	0.16	M6
5/16	2.44	1.64	1.34	0.35	0.94	1.65	1.69	0.33	0.24	0.16	M6
1/2	2.44	1.64	1.34	0.63	0.94	1.65	1.69	0.33	0.24	0.16	M6
1	2.83	1.98	1.73	0.89	1.14	2.17	2.20	0.33	0.24	0.16	M6

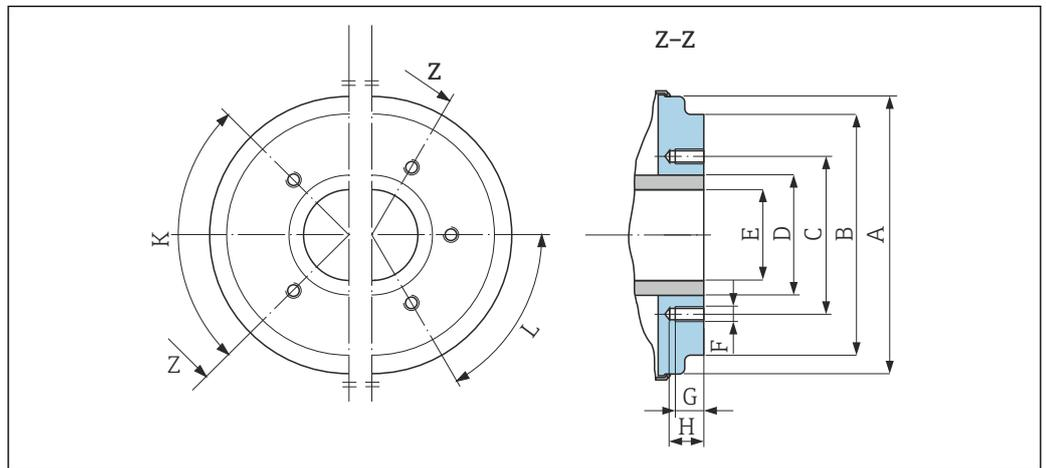

A0005528

63 Front view without process connections

DN	A	B	C	D	E	F	G	H	K	L
[in]	[in]	[in]	[in]	[in]	[in]	[mm]	[in]	[in]	90° ±0.5°	60° ±0.5°
									Tapped holes	
1 1/2	3.93	3.38	2.80	1.90	1.37	M8	0.47	0.67	4	-
2	4.44	3.89	3.29	2.37	1.87	M8	0.47	0.67	4	-
3	5.54	5.26	4.49	3.50	2.87	M8	0.47	0.67	-	6
4	6.56	6.28	5.55	4.50	3.83	M8	0.47	0.67	-	6

DN	A	B	C	D	E	F	G	H	K	L
[in]	[in]	[in]	[in]	[in]	[in]	[mm]	[in]	[in]	90° ±0.5°	60° ±0.5°
									Tapped holes	
5	7.82	7.54	6.73	5.50	4.72	M10	0.59	0.79	-	6
6	8.93	8.64	7.87	6.63	5.78	M10	0.59	0.79	-	6

Flange connections

Flanges with O-ring seal

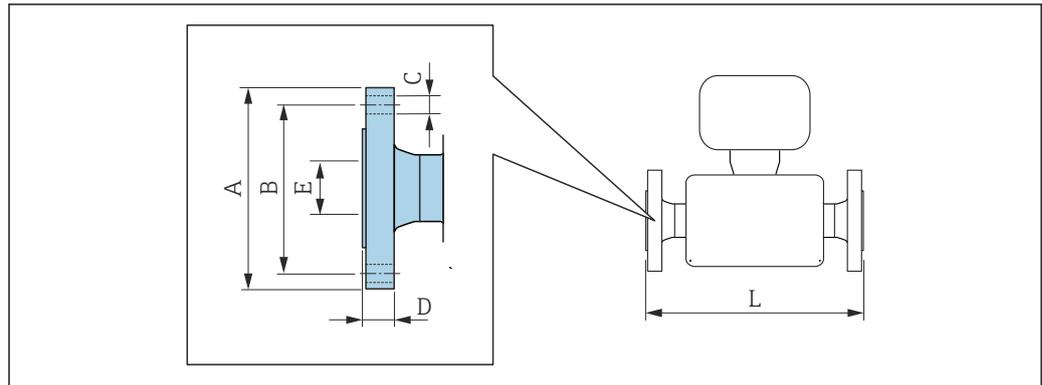

A0015621

Flange similar to ASME B16.5: Class 150 1.4404 (316L)

Order code for "Process connection", option A1S

DN [in]	A [in]	B [in]	C [in]	D [in]	E [in]	L [in]
1/12 to 3/8 ¹⁾	3.50	2.38	4 × Ø0.62	0.44	0.62	8.59
1/2	3.50	2.38	4 × Ø0.62	0.44	0.63	8.59
1	4.25	3.12	4 × Ø0.62	0.56	1.05	9.05

Surface roughness: Ra_{max} = 63 µin

- 1) DN 1/12 to 3/8 with DN 1/2" flanges as standard

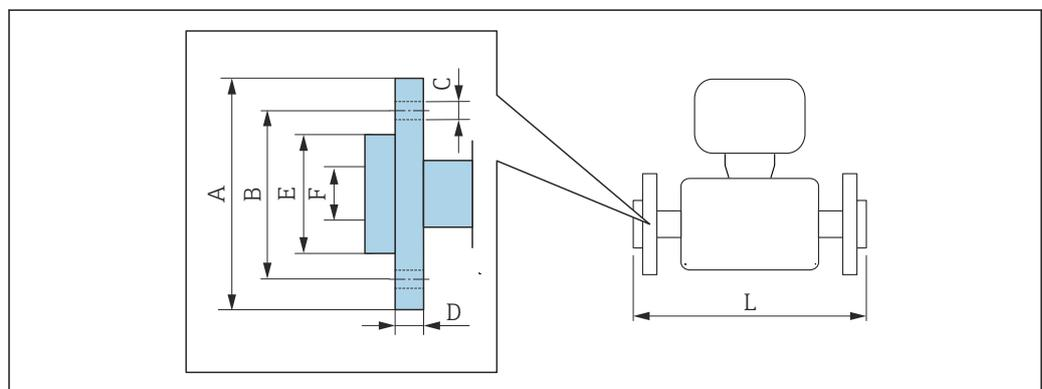

A0022221

Lap joint flange similar to ASME B16.5: Class 150							
PVDF							
<i>Order code for "Process connection", option A1P</i>							
DN [in]	A [in]	B [in]	C [in]	D [in]	E [in]	F [in]	L [in]
$\frac{1}{12}$ to $\frac{3}{8}$ ¹⁾	3.74	2.36	4 × Ø 0.62	0.59	1.38	0.63	7.87
$\frac{1}{2}$	3.74	2.36	4 × Ø 0.62	0.59	1.38	0.63	7.87

Surface roughness: Ra_{max} = 63 µin
 The required grounding rings can be ordered as accessories (order code: DK5HR-****).

1) DN $\frac{1}{12}$ to $\frac{3}{8}$ with DN $\frac{1}{2}$ " flanges as standard

Lap joint flange similar to ASME B16.5: Class 150							
PVDF							
<i>Order code for "Process connection", option A4P</i>							
DN [in]	A [in]	B [in]	C [in]	D [in]	E [in]	F [in]	L [in]
$\frac{1}{12}$ to $\frac{3}{8}$ ¹⁾	3.74	2.36	4 × Ø 0.62	0.59	1.38	0.63	7.87
$\frac{1}{2}$	3.74	2.36	4 × Ø 0.62	0.59	1.38	0.63	7.87

Surface roughness: Ra_{max} = 63 µin
 Grounding rings are not necessary.

1) DN $\frac{1}{12}$ to $\frac{3}{8}$ with DN $\frac{1}{2}$ " flanges as standard

Welding nipple

Welding nipple with aseptic gasket seal

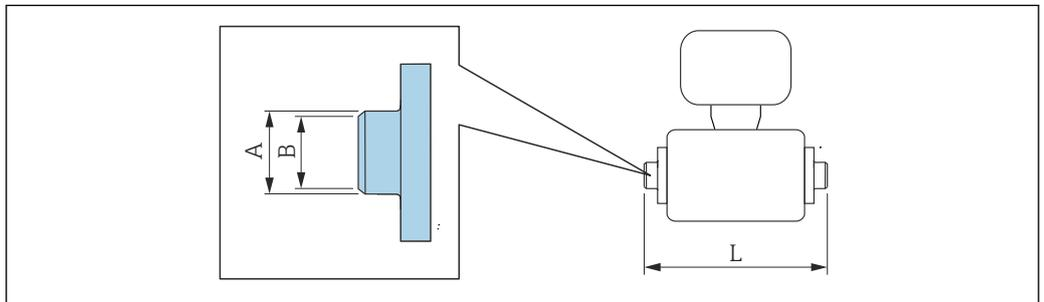

A0027510

Welding nipple according to ISO 2037				
1.4404 (316L), suitable for pipe ISO 2037				
<i>Order code for "Process connection", option IAS</i>				
DN [in]	Suitable for pipe ISO 2037 [in]	A [in]	B [in]	L [in]
$\frac{1}{12}$ to $\frac{3}{8}$	0.50 × 0.06	0.47	0.39	4.65
$\frac{1}{2}$	0.75 × 0.06	0.71	0.63	4.65
1	1.00 × 0.06	0.98	0.89	4.65
1 $\frac{1}{2}$	1.50 × 0.05	1.50	1.40	8.66
2	2.00 × 0.05	2.01	1.91	8.66
3	3.00 × 0.06	3.00	2.87	8.66
4	2.50 × 0.08	4.00	3.84	8.66
5	4.00 × 0.08	5.50	5.34	15.00

Welding nipple according to ISO 2037**1.4404 (316L), suitable for pipe ISO 2037**

Order code for "Process connection", option IAS

DN [in]	Suitable for pipe ISO 2037 [in]	A [in]	B [in]	L [in]
6	6.63 × 0.10	6.63	6.42	15.00

Surface roughness: $Ra_{max} = 31.5 \mu\text{in}$, optional order code for "Service", option HJ: $Ra_{max} = 15 \mu\text{in}$ electropolished
Please note the internal diameters of the measuring pipe and process connection (B) when cleaning with pigs.

Welding nipple according to ASME BPE**1.4404 (316L), suitable for pipe according to ASME BPE and DIN 11866 series C**

Order code for "Process connection", option AAS

DN [in]	Suitable for pipe according to ASME BPE [in]	A [in]	B [in]	L [in]
$\frac{1}{12}$ to $\frac{3}{8}$	0.50 × 0.06	0.50	0.35	4.65
$\frac{1}{2}$	0.75 × 0.06	0.75	0.63	4.65
1	1.00 × 0.06	1.00	0.89	4.65
1 $\frac{1}{2}$	1.50 × 0.06	1.50	1.37	8.66
2	2.00 × 0.06	2.00	1.87	8.66
3	3.00 × 0.06	3.00	2.87	8.66
4	4.00 × 0.08	4.00	3.83	8.66
6	6.00 × 0.11	6.00	5.78	11.80

Surface roughness: $Ra_{max} = 31.5 \mu\text{in}$, optional order code for "Service", option HJ: $Ra_{max} = 15 \mu\text{in}$ electropolished
Please note the internal diameters of the measuring pipe and process connection (B) when cleaning with pigs.

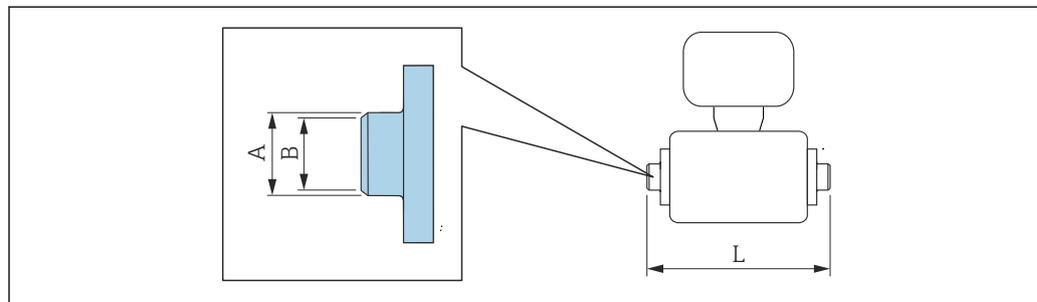
Welding nipple with O-ring seal

A0027510

Welding nipple according to ISO 1127**1.4404 (316L), suitable for pipe according to ISO 1127 series 1**

Order code for "Process connection", option A2S

DN [in]	Suitable for pipe according to ISO 1127 series 1 [in]	A [in]	B [in]	L [in]
$\frac{1}{12}$ to $\frac{3}{8}$	0.53 × 0.09	0.53	0.35	4.99
$\frac{1}{2}$	0.84 × 0.10	0.84	0.63	4.99

Surface roughness: $Ra_{max} = 63 \mu\text{in}$

Clamp connections

Clamp connections with aseptic gasket seal

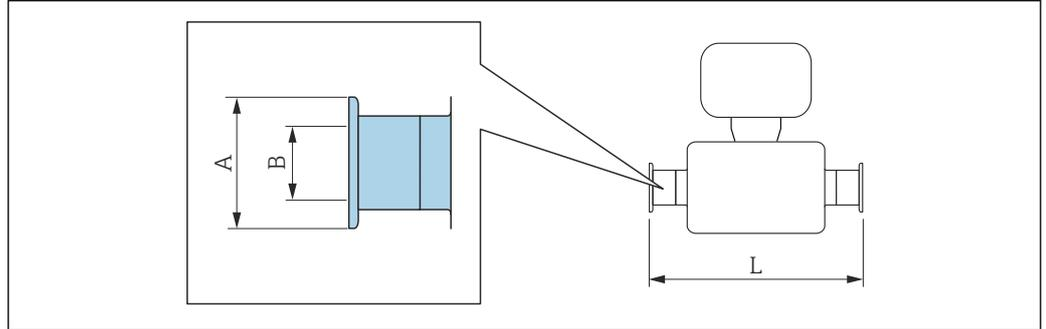

A0015625

Tri-Clamp
1.4404 (316L), suitable for pipe according to ASME BPE and DIN 11866 series C
Order code for "Process connection", option FAS

DN [in]	Suitable for pipe according to ASME BPE [in]	A [in]	B [in]	L [in]
1/12 to 3/8	1/2	1	0.37	5.63
1/2	3/4	1	0.62	5.63
1	1	2	0.87	5.63
1 1/2	1.50 × 0.06	1.98	1.37	8.66
2	2.00 × 0.06	2.52	1.87	8.66
3	3.00 × 0.06	3.58	2.87	8.66
4	4.00 × 0.08	4.68	3.83	8.66
6	6.00 × 0.11	6.57	5.90	11.80

Surface roughness: Ra_{max} = 31.5 µin, optional order code for "Service", option HJ: Ra_{max} = 15 µin electropolished
 Please note the internal diameters of the measuring pipe and process connection (B) when cleaning with pigs.

Clamp according to ISO 2852, Fig. 2
1.4404 (316L)
Order code for "Process connection", option IBS

DN [in]	Suitable for pipe ISO 2037 [in]	DN Clamp ISO 2852 [in]	A [in]	B [in]	L [in]
1	0.96 × 0.06	1	2.00	0.89	6.87
1 1/2	1.50 × 0.06	1.50	1.99	1.40	8.66
2	2.00 × 0.06	2.01	2.52	1.91	8.66
3	3.00 × 0.06	3.00	3.58	2.87	8.66
4	2.50 × 0.08	4.00	4.69	3.84	8.66
5	4.00 × 0.08	5.50	6.10	5.34	11.80
6	6.63 × 0.10	6.63	7.20	6.42	11.80

Surface roughness: Ra_{max} = 31.5 µin, optional order code for "Service", option HJ: Ra_{max} = 15 µin electropolished
 Please note the internal diameters of the measuring pipe and process connection (B) when cleaning with pigs.

Couplings

Thread with aseptic gasket seal

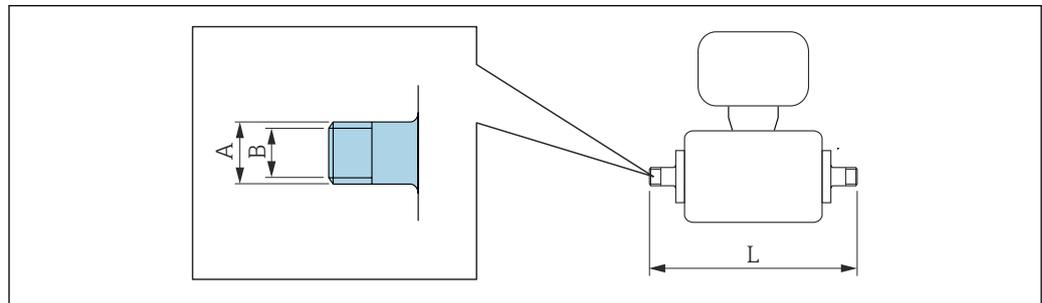

A0027509

Coupling DIN 11851, thread
1.4404 (316L), suitable for pipe EN 10357 series B
 Order code for "Process connection", option DCS

DN [in]	Suitable for pipe EN 10357 series B [in]	A [in]	B [in]	L [in]
$\frac{1}{12}$ to $\frac{5}{16}$	0.47×0.04 (DN 1/8)	Rd $1.10 \times \frac{1}{8}$	0.39	6.85
$\frac{1}{2}$	0.71×0.06	Rd $1.34 \times \frac{1}{8}$	0.63	6.85
1	1.10×0.04 or 1.10×0.06	Rd $2.05 \times \frac{1}{8}$	1.02	7.48

Surface roughness: $Ra_{max} = 31.5 \mu\text{m}$, optional order code for "Service", option HJ: $Ra_{max} = 15 \mu\text{m}$ electropolished
 Please note the internal diameters of the measuring pipe and process connection (B) when cleaning with pigs.

Coupling DIN 11851, thread
1.4404 (316L), suitable for pipe EN 10357 series A
 Order code for "Process connection", option DCS

DN [in]	Suitable for pipe EN 10357 series A [in]	A [in]	B [in]	L [in]
1 1/2	1.65×0.06	Rd $2.56 \times \frac{1}{8}$	1.50	10.20
2	2.13×0.06	Rd $3.07 \times \frac{1}{8}$	1.97	10.20
3	3.35×0.08	Rd $4.33 \times \frac{1}{4}$	3.19	11.00
4	4.09×0.08	Rd $5.12 \times \frac{1}{4}$	3.94	11.40
5	5.08×0.08	Rd $6.30 \times \frac{1}{4}$	4.92	15.00
6	6.06×0.08	Rd $6.30 \times \frac{1}{4}$	5.91	15.40

Surface roughness: $Ra_{max} = 31.5 \mu\text{m}$, optional order code for "Service", option HJ: $Ra_{max} = 15 \mu\text{m}$ electropolished
 Please note the internal diameters of the measuring pipe and process connection (B) when cleaning with pigs.

Coupling ISO 2853, thread
1.4404 (316L)
 Order code for "Process connection", option ICS

DN [in]	Suitable for pipe EN 10357 (DIN 11850) [in]	DN Clamp ISO 2853 [in]	A [in]	B [in]	L [in]
1 1/2	1.50×0.06	1.50	Tr 2.00×0.13	1.40	10.80
2	2.00×0.06	2.01	Tr 2.52×0.13	1.91	10.80
3	3.00×0.06	3.00	Tr 3.58×0.13	2.87	10.90
4	2.50×0.08	4.00	Tr 4.65×0.13	3.84	11.30

Surface roughness: $Ra_{max} = 31.5 \mu\text{m}$, optional order code for "Service", option HJ: $Ra_{max} = 15 \mu\text{m}$ electropolished
 Please note the internal diameters of the measuring pipe and process connection (B) when cleaning with pigs.

Coupling SMS 1145, thread 1.4404 (316L)
Order code for "Process connection", option SAS

DN [in]	Suitable for pipe [in]	DN SMS 1145 [in]	A [in]	B [in]	L [in]
1	1	1	Rd1.57 × 0.17	0.89	5.81
1 ½	1.50 × 0.06	1.50	Rd 2.36 × ¼	1.37	10.10
2	2.00 × 0.06	2.00	Rd 2.76 × ¼	1.87	10.10
3	3.00 × 0.06	3.00	Rd 3.86 × ¼	2.86	10.90
4	4.00 × 0.08	4.00	Rd 5.20 × ¼	3.83	11.30

Surface roughness: Ra_{max} = 31.5 µin, optional order code for "Service", option HJ: Ra_{max} = 15 µin electropolished
 Please note the internal diameters of the measuring pipe and process connection (B) when cleaning with pigs.

Thread with O-ring seal

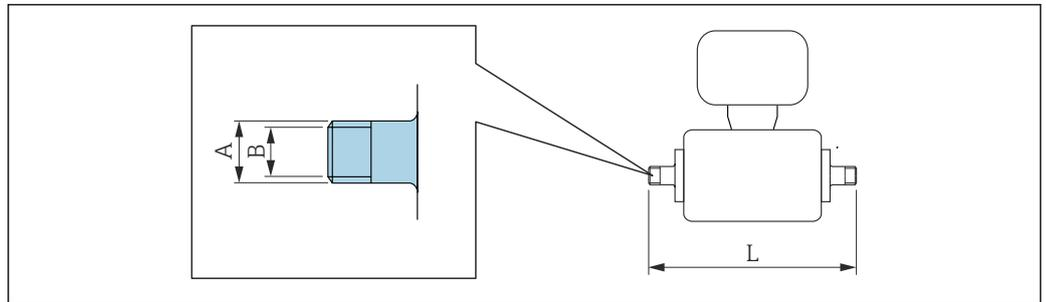

External thread according to ISO 228/DIN 2999 1.4404 (316L)
Order code for "Process connection", option I2S

DN [in]	Suitable for internal thread ISO 228/DIN 2999 [in]	A [in]	B [in]	L [in]
¼ ₁₂ to ¾ ₈	R ¾ ₈	R 0.40 × ¾ ₈	0.39	6.53
½	R ½	R 0.52 × ½	0.63	6.53
1	R 1	R 0.66 × 1	0.98	6.69

Surface roughness: Ra_{max} = 63 µin

Internal thread according to ISO 228/DIN 2999 1.4404 (316L)
Order code for "Process connection", option I3S

DN [in]	Suitable for external thread ISO 228/DIN 2999 [in]	A [in]	B [in]	L [in]
¼ ₁₂ to ¾ ₈	Rp ¾ ₈	Rp 0.51 × ¾ ₈	0.35	6.93
½	Rp ½	Rp 0.55 × ½	0.63	6.93
1	Rp 1	Rp 0.67 × 1	1.07	7.41

Surface roughness: Ra_{max} = 63 µin

Adhesive sleeves

Adhesive sleeves with O-ring seal

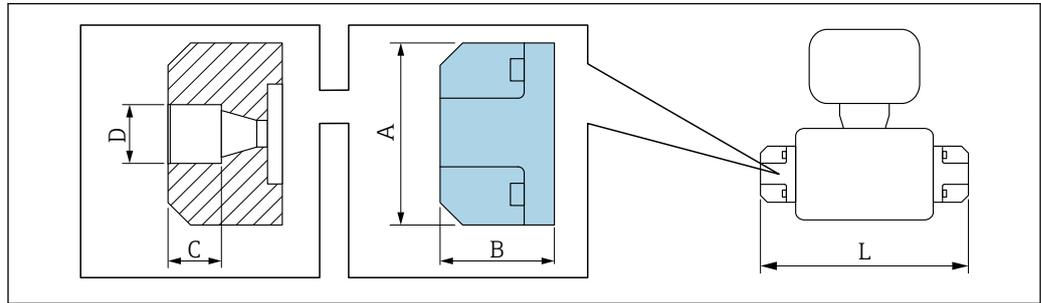

A0036663

**Adhesive sleeve
PVC**

Order code for "Process connection", option O1V

DN [in]	Suitable for pipe [in]	A [in]	B [in]	C [in]	D [in]	L [in]
1/12 to 3/8	1/2	2.44	1.52	0.71	0.85	6.42

Surface roughness: Ra_{max} = 63 µin

The required grounding rings can be ordered as accessories (order code: DK5HR-****).

Mounting kits

Wall mounting kit

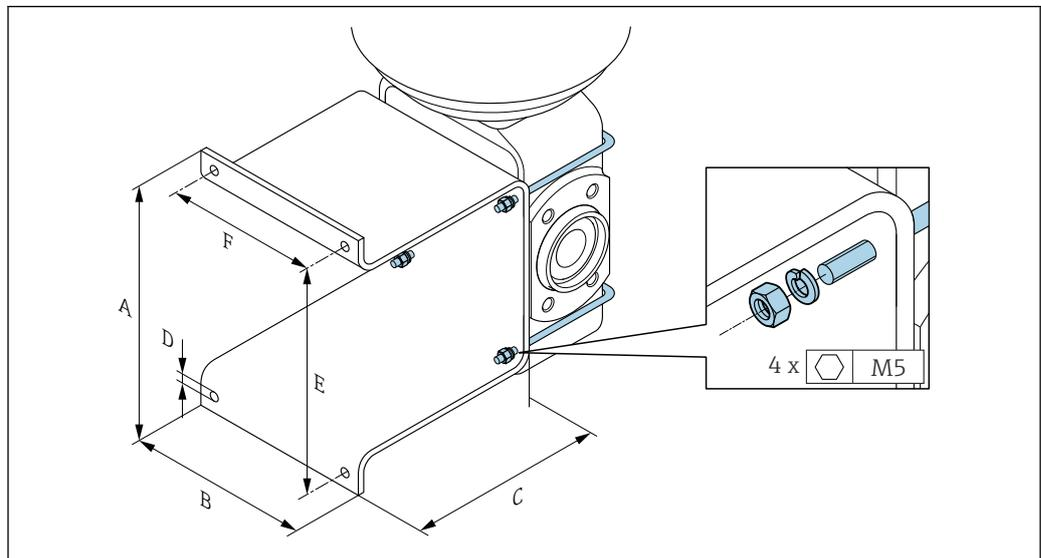

A0005537

A [in]	B [in]	C [in]	Ø D [in]	E [in]	F [in]
5.39	4.33	4.72	0.28	4.92	3.46

Accessories

Weather protection cover

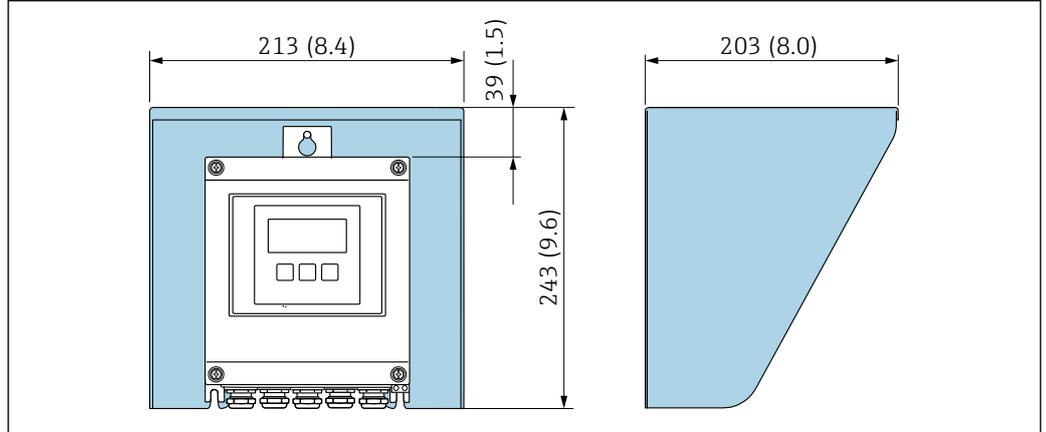

A0029552

64 Weather protection cover for Proline 500 – digital; engineering unit mm (in)

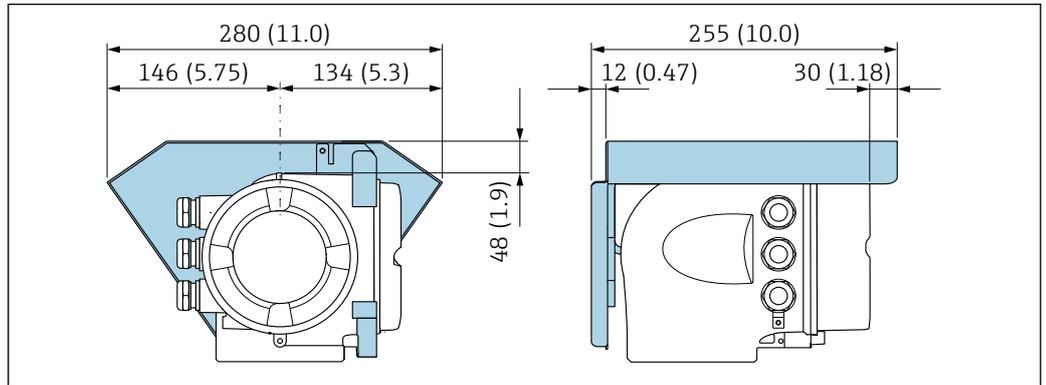

A0029553

65 Weather protection cover for Proline 500; engineering unit mm (in)

External WLAN antenna

i The external WLAN antenna is not suitable for use in hygienic applications.

Proline 500 – digital

External WLAN antenna mounted on device

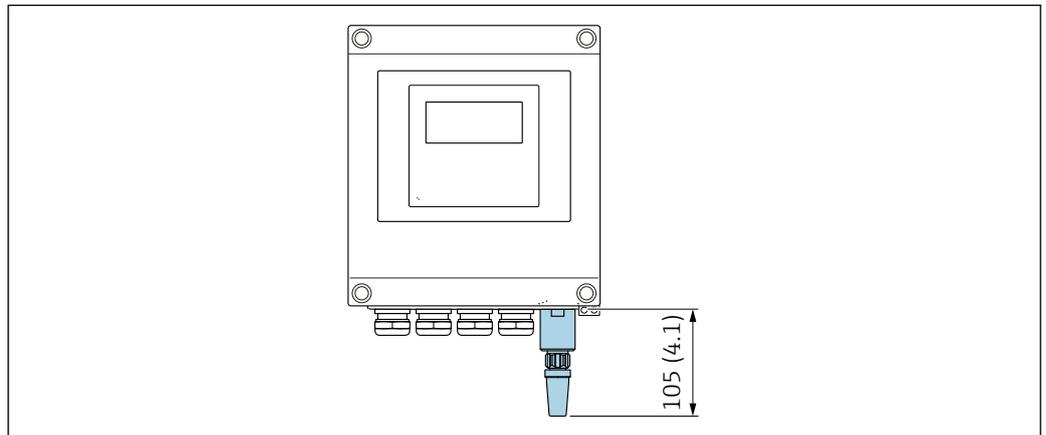

A0033607

66 Engineering unit mm (in)

External WLAN antenna mounted with cable

The external WLAN antenna can be mounted separately from the transmitter if the transmission/reception conditions at the transmitter mounting location are poor.

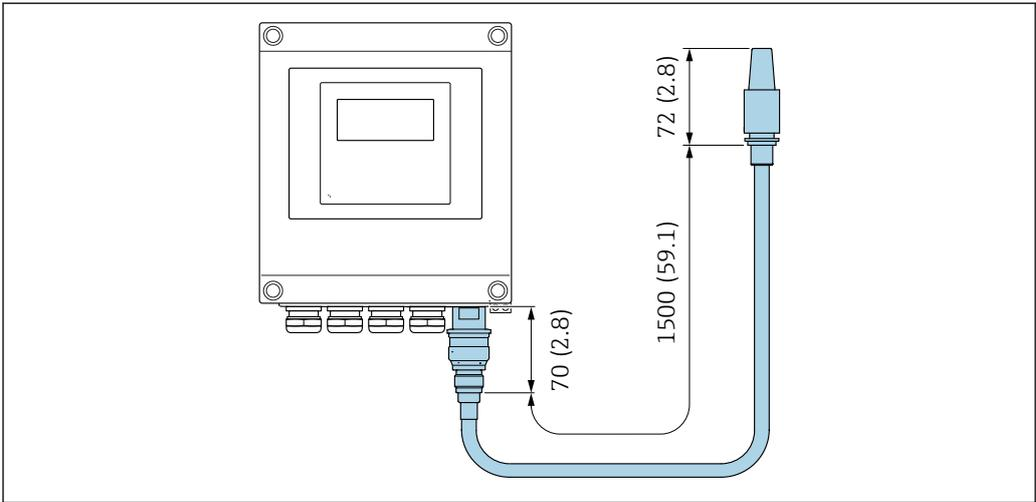

A0033606

67 Engineering unit mm (in)

Proline 500

External WLAN antenna mounted on device

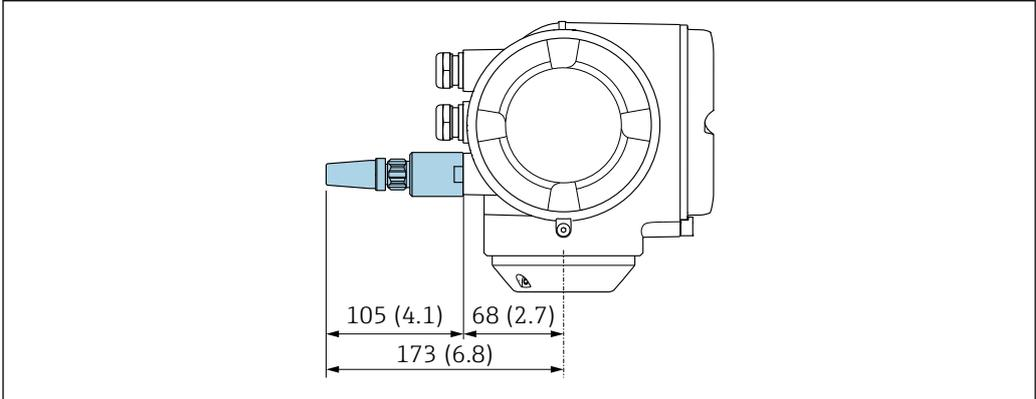

A0028923

68 Engineering unit mm (in)

External WLAN antenna mounted with cable

The external WLAN antenna can be mounted separately from the transmitter if the transmission/reception conditions at the transmitter mounting location are poor.

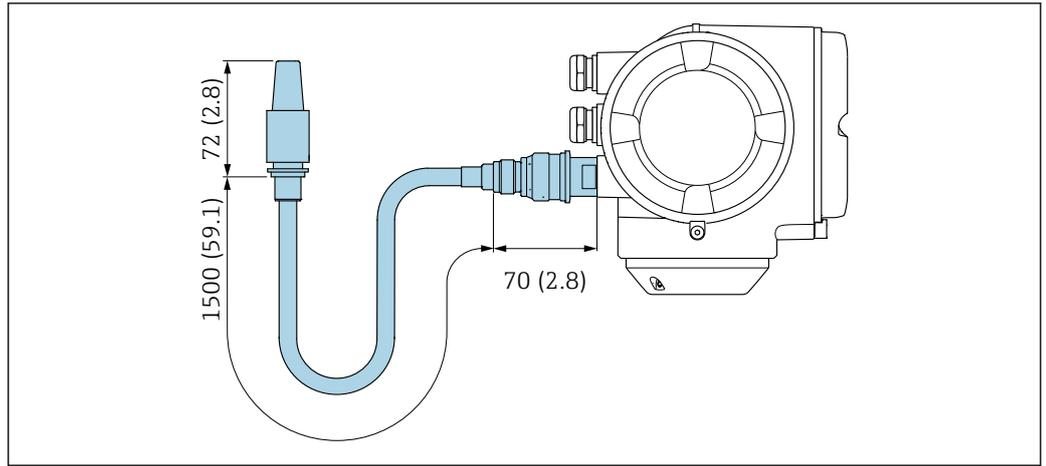

A0033597

69 Engineering unit mm (in)

Spacer

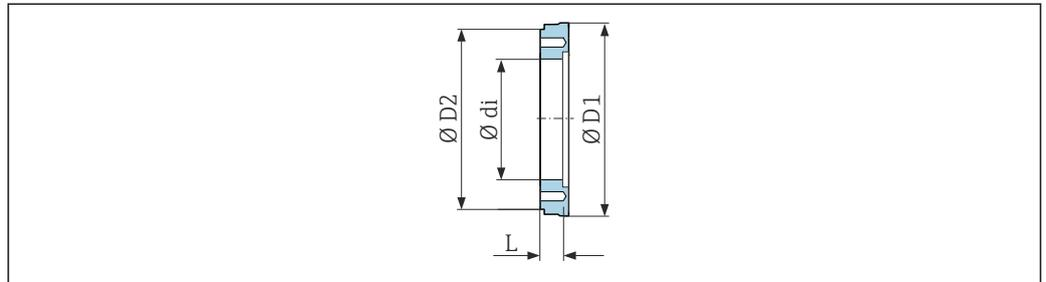

A0017294

Order code: DK5HB-****				
DN [in]	di [in]	D1 [in]	D2 [in]	L [in]
3	2.87	5.54	5.55	1.30
4	3.83	6.56	6.38	1.30

Clamp connections with aseptic gasket seal available for order

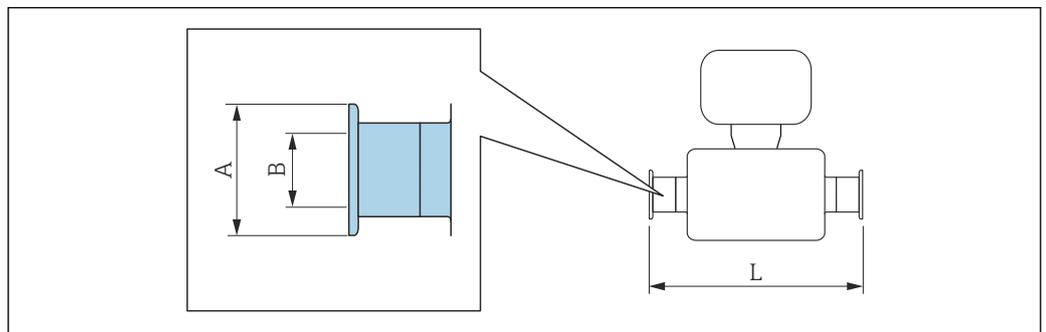

A0015625

70 Hygienic clamp adapter connection suitable for pipes with connection according to ASME BPE (reduction)

Tri-Clamp

1.4404 (316L), suitable for pipe according to ASME BPE and BS 4825, reduction from pipe OD 1" (Tri-Clamp connection) to device DN 15

Order code: DKH**-HF**

DN [in]	Suitable for pipe according to ASME BPE and BS 4825 (reduction) [in]	A [in]	B [in]	L [in]
½	Pipe OD 1"	2	0.87	5.63

Surface roughness: $Ra_{max} = 31.5 \mu\text{in}$, optional order code for "Design", option CB: $Ra_{max} = 15 \mu\text{in}$ electropolished
Please note the internal diameters of the measuring pipe and process connection (B) when cleaning with pigs.

Couplings with O-ring seal available for order

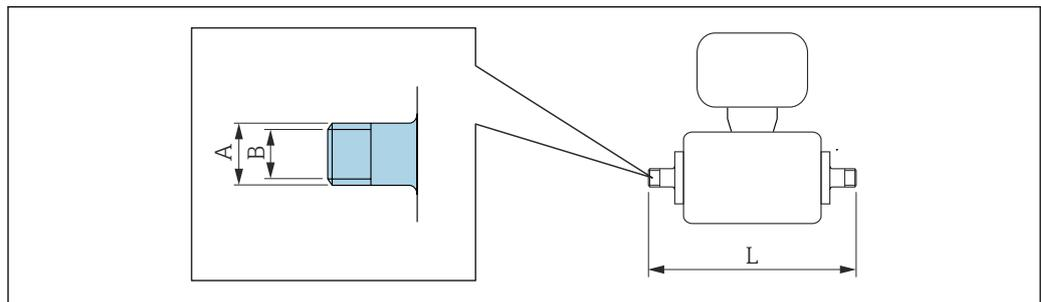

A0027509

External thread

1.4404 (316L)

Order code: DKH**-GD**

DN [in]	Suitable for internal thread NPT [in]	A [in]	B [in]	L [in]
½ to ¾	NPT ¾	R 0.61 × ¾	0.39	7.39
½	NPT ½	R 0.79 × ½	0.63	7.39
1	NPT 1	R 1 × 1	1.00	7.73

Surface roughness: $Ra_{max} = 63 \mu\text{in}$

Internal thread

1.4404 (316L)

Order code: DKH**-GC**

DN [in]	Suitable for external thread NPT [in]	A [in]	B [in]	L [in]
½ to ¾	NPT ¾	R 0.51 × ¾	0.35	6.93
½	NPT ½	R 0.55 × ½	0.63	6.93
1	NPT 1	R 0.67 × 1	1.07	7.41

Surface roughness: $Ra_{max} = 63 \mu\text{in}$

Grounding rings

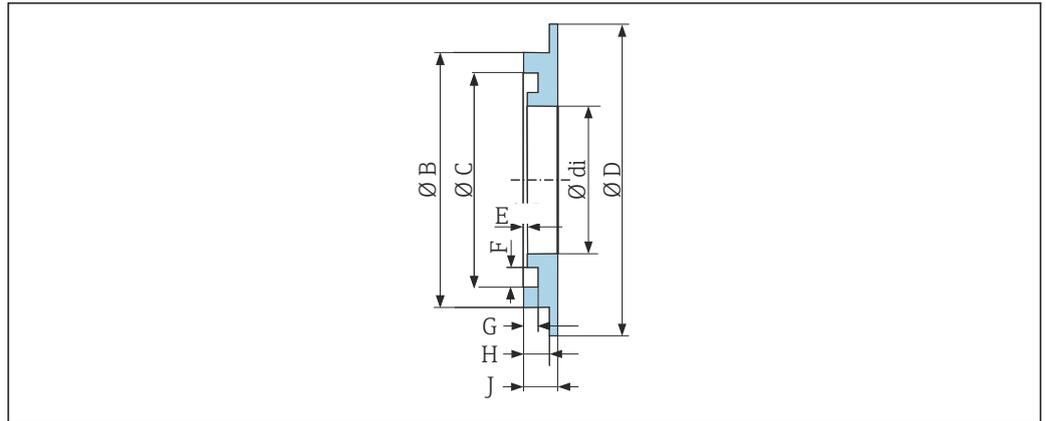

A0017673

For lap joint flange made of PVDF and PVC adhesive sleeve 1.4435 (316L), Alloy C22, tantalum Order code: DK5HR-****									
DN [in]	di [in]	B [in]	C [in]	D [in]	E [in]	F [in]	G [in]	H [in]	J [in]
1/12 to 3/8	0.35	0.87	0.69	1.33	0.02	0.14	0.07	0.13	0.18
1/2	0.63	1.14	0.97	1.33	0.02	0.14	0.07	0.13	0.18
1	0.89	1.44	1.23	1.73	0.02	0.14	0.07	0.13	0.18

Weight

All values (weight exclusive of packaging material) refer to devices with flanges of the standard pressure rating.

The weight may be lower than indicated depending on the pressure rating and design.

Transmitter

- Proline 500 – digital polycarbonate: 1.4 kg (3.1 lbs)
- Proline 500 – digital aluminum: 2.4 kg (5.3 lbs)
- Proline 500 aluminum: 6.5 kg (14.3 lbs)

Sensor

Sensor with aluminum connection housing version:

Nominal diameter		Weight	
[mm]	[in]	[kg]	[lbs]
2	1/12	2.00	4.41
4	5/32	2.00	4.41
8	5/16	2.00	4.41
15	1/2	1.90	4.19
25	1	2.80	6.17
40	1 1/2	4.10	9.04
50	2	4.60	10.1
65	-	5.40	11.9
80	3	6.00	13.2
100	4	7.30	16.1
125	5	12.7	28.0
150	6	15.1	33.3

Measuring tube specification

Nominal diameter		Pressure rating ¹⁾	Process connection internal diameter	
[mm]	[in]	EN (DIN)	PFA	
		[bar]	[mm]	[in]
2	1/12	PN 16/40	2.25	0.09
4	5/32	PN 16/40	4.5	0.18
8	5/16	PN 16/40	9.0	0.35
15	½	PN 16/40	16.0	0.63
-	1	PN 16/40	22.6 ²⁾	0.89 ²⁾
25	-	PN 16/40	26.0 ³⁾	1.02 ³⁾
40	1 ½	PN 16/25/40	35.3	1.39
50	2	PN 16/25	48.1	1.89
65	-	PN 16/25	59.9	2.36
80	3	PN 16/25	72.6	2.86
100	4	PN 16/25	97.5	3.84
125	5	PN 10/16	120.0	4.72
150	6	PN 10/16	146.5	5.77

1) Depending on process connection and seals used

2) Order code 5H**22

3) Order code 5H**26

Materials

Transmitter housing

Housing of Proline 500 – digital transmitter

Order code for "Transmitter housing":

- Option **A** "Aluminum coated": aluminum, AlSi10Mg, coated
- Option **D** "Polycarbonate": polycarbonate

Housing of Proline 500 transmitter

Order code for "Transmitter housing":

Option **A** "Aluminum coated": aluminum, AlSi10Mg, coated

Window material

Order code for "Transmitter housing":

- Option **A** "Aluminum, coated": glass
- Option **D** "Polycarbonate": plastic

Sensor connection housing

Order code for "Sensor connection housing":

- Option **A** "Aluminum coated": aluminum, AlSi10Mg, coated
- Option **B** "Stainless, hygienic":
Stainless steel 1.4301 (304)
- Option **C** "Ultra-compact hygienic, stainless":
Stainless steel 1.4301 (304)

Cable entries/cable glands

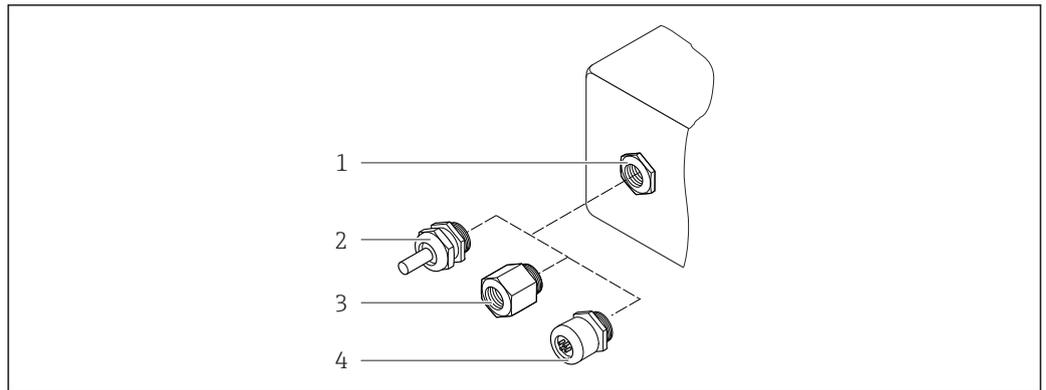

A0028352

71 Possible cable entries/cable glands

- 1 Female thread M20 × 1.5
- 2 Cable gland M20 × 1.5
- 3 Adapter for cable entry with female thread G ½" or NPT ½"
- 4 Device plug

Cable entries and adapters	Material
Cable gland M20 × 1.5	Plastic
<ul style="list-style-type: none"> ▪ Adapter for cable entry with female thread G ½" ▪ Adapter for cable entry with female thread NPT ½" <p>i Only available for certain device versions:</p> <ul style="list-style-type: none"> ▪ Order code for "Transmitter housing": <ul style="list-style-type: none"> ▪ Option A "Aluminum, coated" ▪ Option D "Polycarbonate" ▪ Order code for "Sensor connection housing": <ul style="list-style-type: none"> ▪ Proline 500 – digital: <ul style="list-style-type: none"> Option A "Aluminum coated" Option B "Stainless" ▪ Proline 500: <ul style="list-style-type: none"> Option A "Aluminum coated" Option C "Stainless, hygienic" 	Nickel-plated brass
<p>Adapter for device plug</p> <p>i</p> <ul style="list-style-type: none"> ▪ Device plug for digital communication: Only available for certain device versions → 33. ▪ Device plug for connecting cable: A device plug is always used for the device version, order code for "Sensor connection housing", option C (ultra-compact, hygienic, stainless). 	Stainless steel, 1.4404 (316L)

Device plug

Electrical connection	Material
Plug M12x1	<ul style="list-style-type: none"> ▪ Socket: Stainless steel, 1.4404 (316L) ▪ Contact housing: Polyamide ▪ Contacts: Gold-plated brass

Connecting cables

i UV rays can impair the cable outer sheath. Protect the cable from exposure to sun as much as possible.

Connecting cable for sensor - Proline 500 – digital transmitter

PVC cable with copper shield

Connecting cable for sensor - Proline 500 transmitter

PVC cable with copper shield

Sensor housing

Stainless steel 1.4301 (304)

Measuring tubes

Stainless steel 1.4301 (304)

Liner

PFA (USP Class VI, FDA 21 CFR 177.2600)

Process connections

- Stainless steel, 1.4404 (F316L)
- PVDF
- PVC adhesive sleeve

Electrodes

Standard: 1.4435 (316L)

Seals

- O-ring seal, DN 2 to 25 (1/12 to 1"): EPDM, FKM²⁾, Kalrez
- Aseptic³⁾ gasket seal, DN 2 to 150 (1/12 to 6"): EPDM, FKM²⁾, VMQ (silicone)

Accessories

Protective cover

Stainless steel, 1.4404 (316L)

External WLAN antenna

- Antenna: ASA plastic (acrylonitrile styrene acrylate) and nickel-plated brass
- Adapter: Stainless steel and nickel-plated brass
- Cable: Polyethylene
- Plug: Nickel-plated brass
- Angle bracket: Stainless steel

Grounding rings

- Standard: 1.4435 (316L)
- Optional: Alloy C22, tantalum

Wall mounting kit

Stainless steel, 1.4301 (304)⁴⁾

Centering star

1.4435 (F316L)

Fitted electrodes

- 2 measuring electrodes for signal detection
- 1 empty pipe detection electrode for empty pipe detection/temperature measurement (only DN 15 to 150 (½ to 6"))

Process connections

With O-ring seal:

- Welding nipple (DIN EN ISO 1127, ODT/SMS, ISO 2037)
- Flange (EN (DIN), ASME, JIS)
- Flange from PVDF (EN (DIN), ASME, JIS)

2) USP Class VI, FDA 21 CFR 177.2600, 3A

3) In this context, aseptic means hygienic design

4) Does not meet the hygienic design installation guidelines.

- Male thread
- Female thread
- Hose connection
- PVC adhesive sleeve

With aseptic gasket seal:

- Coupling (DIN 11851, DIN 11864-1, ISO 2853, SMS 1145)
- Flange DIN 11864-2



For information on the different materials used in the process connections → 114

Surface roughness

Electrodes:

- Stainless steel, 1.4435 (316L) electropolished $\leq 0.5 \mu\text{m}$ (19.7 μin)
- Alloy C22, 2.4602 (UNSN06022); tantalum $\leq 0.5 \mu\text{m}$ (19.7 μin)

(All data refer to parts in contact with the medium)

Liner with PFA:

$\leq 0.4 \mu\text{m}$ (15.7 μin)

(All data refer to parts in contact with the medium)

Stainless steel process connections:

- With O-ring seal: $\leq 1.6 \mu\text{m}$ (63 μin)
- With aseptic seal: $R_{\text{max}} = 0.76 \mu\text{m}$ (31.5 μin)
Optional: $R_{\text{max}} = 0.38 \mu\text{m}$ (15 μin) electropolished

(All data refer to parts in contact with the medium)

Operability

Operation concept

Operator-oriented menu structure for user-specific tasks

- Commissioning
- Operation
- Diagnosis
- Expert level

Quick and safe commissioning

- Guided menus ("Make-it-run" wizards) for applications
- Menu guidance with brief descriptions of the individual parameter functions
- Access to the device via web server
- WLAN access to the device via mobile handheld terminal, tablet or smart phone

Reliable operation

- Operation in local language
- Uniform operating philosophy applied to device and operating tools
- If replacing electronic modules, transfer the device configuration via the integrated memory (HistoROM backup) which contains the process and measuring device data and the event logbook. No need to reconfigure.

Efficient diagnostics increase measurement reliability

- Troubleshooting measures can be called up via the device and in the operating tools
- Diverse simulation options, logbook for events that occur and optional line recorder functions

Languages

Can be operated in the following languages:

- Via local operation
English, German, French, Spanish, Italian, Dutch, Portuguese, Polish, Russian, Turkish, Chinese, Japanese, Korean, Vietnamese, Czech, Swedish
- Via web browser
English, German, French, Spanish, Italian, Dutch, Portuguese, Polish, Russian, Turkish, Chinese, Japanese, Vietnamese, Czech, Swedish
- Via "FieldCare", "DeviceCare" operating tool: English, German, French, Spanish, Italian, Chinese, Japanese

Onsite operation**Via display module**

Features:

- Order code for "Display; operation", option F "4-line, illuminated, graphic display; touch control"
- Order code for "Display; operation", option G "4-line, illuminated, graphic display; touch control + WLAN"

 Information about WLAN interface →  123

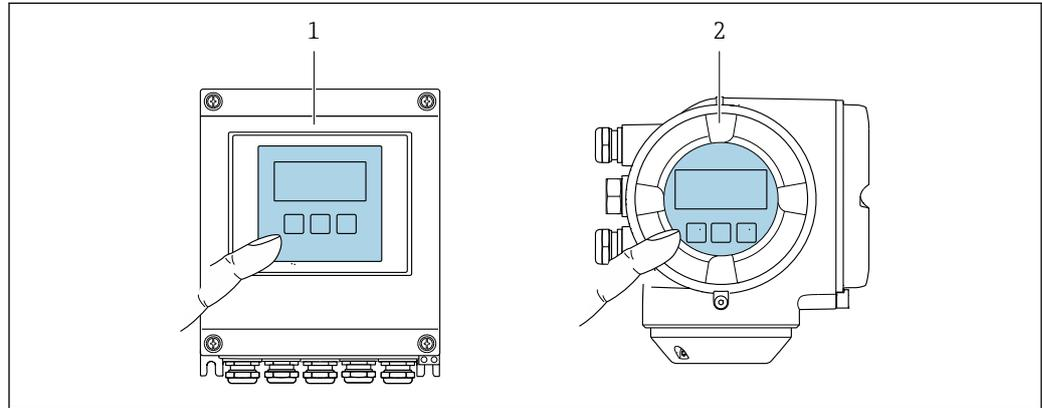

A0028232

 72 Operation with touch control

- 1 Proline 500 - digital
- 2 Proline 500

Display elements

- 4-line, illuminated, graphic display
- White background lighting; switches to red in event of device errors
- Format for displaying measured variables and status variables can be individually configured

Operating elements

- External operation via touch control (3 optical keys) without opening the housing: , , 
- Operating elements also accessible in the various zones of the hazardous area

Remote operation**Via HART protocol**

This communication interface is available in device versions with a HART output.

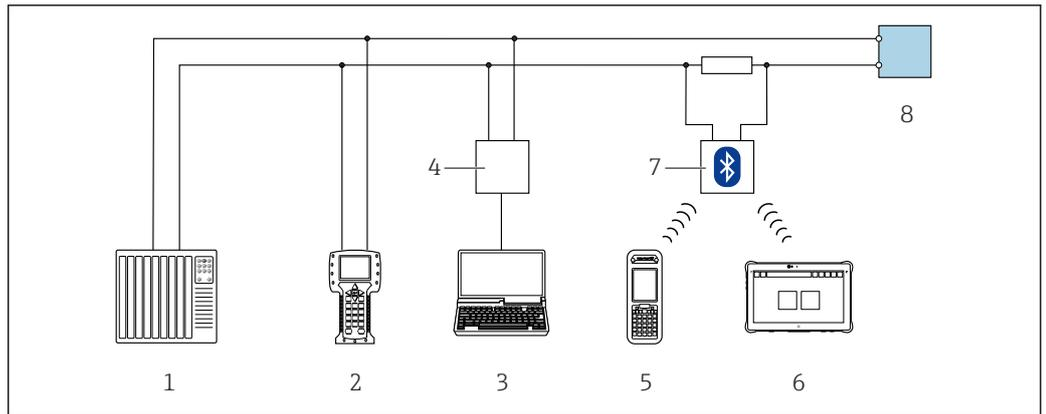

A0028747

73 Options for remote operation via HART protocol (active)

- 1 Control system (e.g. PLC)
- 2 Field Communicator 475
- 3 Computer with web browser (e.g. Microsoft Edge) to access the integrated device web server or computer with operating tool (e.g. FieldCare, DeviceCare, AMS Device Manager, SIMATIC PDM) with COM DTM "CDI Communication TCP/IP"
- 4 Commubox FXA195 (USB)
- 5 Field Xpert SFX350 or SFX370
- 6 Field Xpert SMT70
- 7 VIATOR Bluetooth modem with connecting cable
- 8 Transmitter

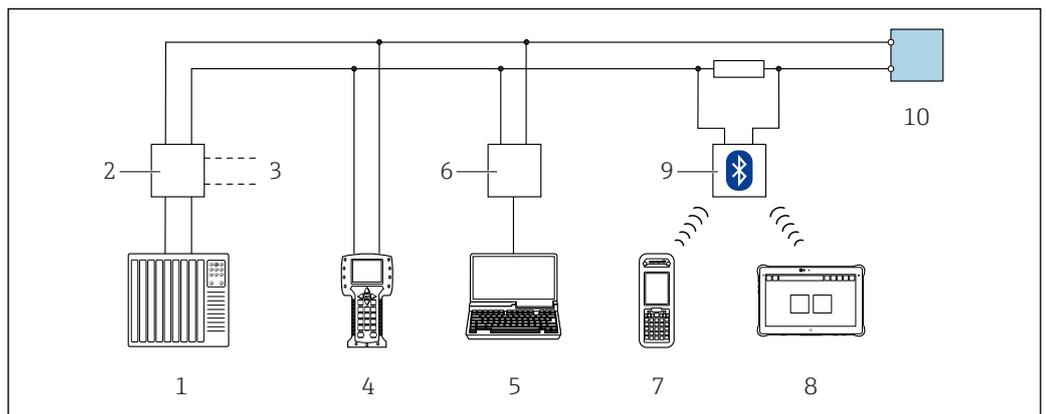

A0028746

74 Options for remote operation via HART protocol (passive)

- 1 Control system (e.g. PLC)
- 2 Transmitter power supply unit, e.g. RN221N (with communication resistor)
- 3 Connection for Commubox FXA195 and Field Communicator 475
- 4 Field Communicator 475
- 5 Computer with web browser (e.g. Microsoft Edge) to access the integrated device web server or computer with operating tool (e.g. FieldCare, DeviceCare, AMS Device Manager, SIMATIC PDM) with COM DTM "CDI Communication TCP/IP"
- 6 Commubox FXA195 (USB)
- 7 Field Xpert SFX350 or SFX370
- 8 Field Xpert SMT70
- 9 VIATOR Bluetooth modem with connecting cable
- 10 Transmitter

Via FOUNDATION Fieldbus network

This communication interface is available in device versions with FOUNDATION Fieldbus.

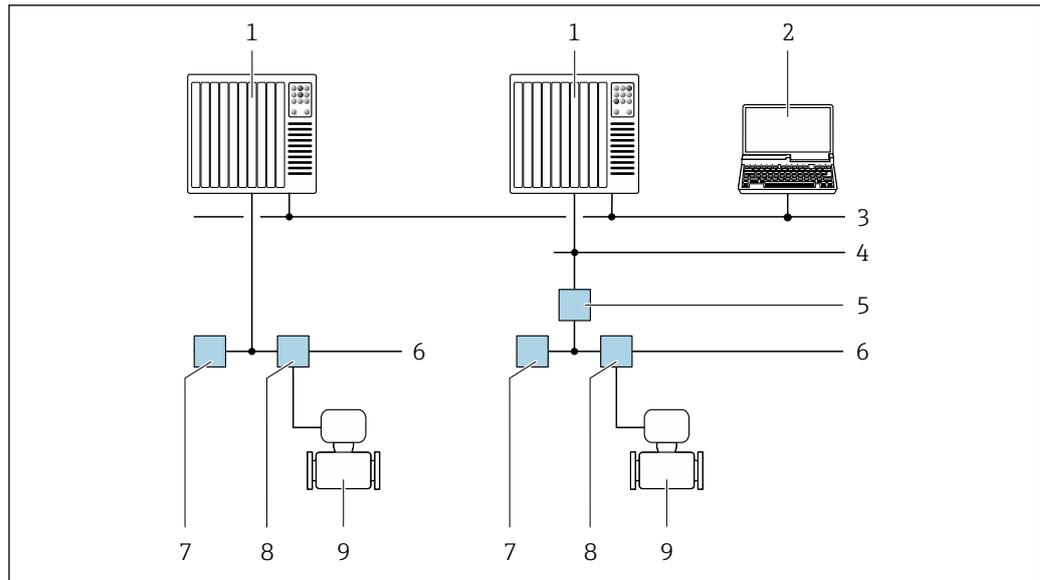

A0028837

75 Options for remote operation via FOUNDATION Fieldbus network

- 1 Automation system
- 2 Computer with FOUNDATION Fieldbus network card
- 3 Industry network
- 4 High Speed Ethernet FF-HSE network
- 5 Segment coupler FF-HSE/FF-H1
- 6 FOUNDATION Fieldbus FF-H1 network
- 7 Power supply FF-H1 network
- 8 T-box
- 9 Measuring device

Via PROFIBUS DP network

This communication interface is available in device versions with PROFIBUS DP.

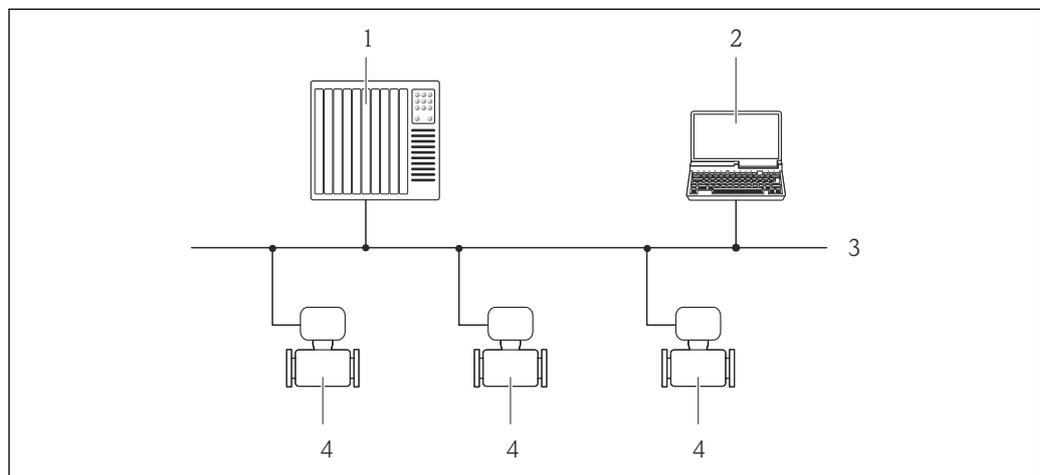

A0020903

76 Options for remote operation via PROFIBUS DP network

- 1 Automation system
- 2 Computer with PROFIBUS network card
- 3 PROFIBUS DP network
- 4 Measuring device

Via PROFIBUS PA network

This communication interface is available in device versions with PROFIBUS PA.

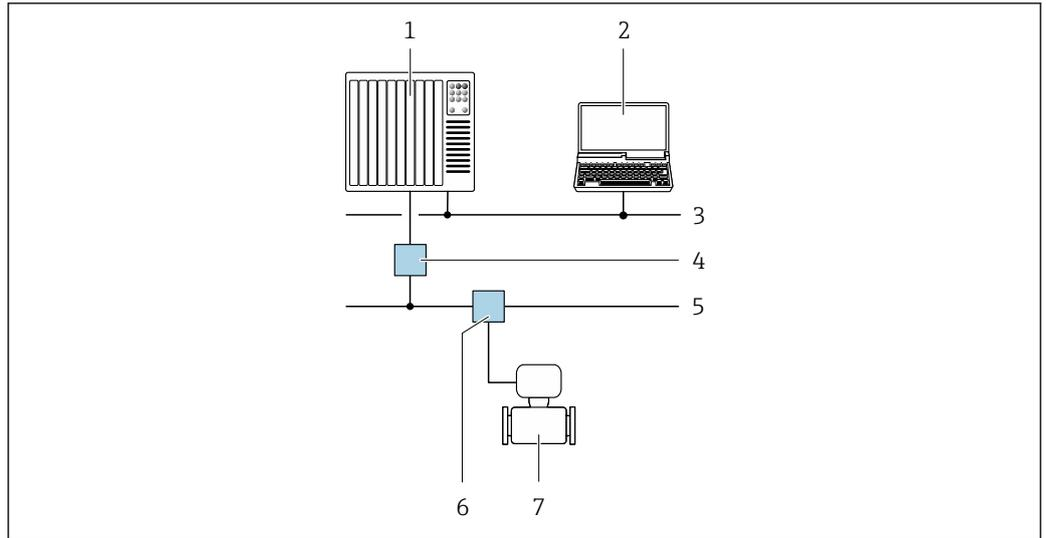

A0028838

77 Options for remote operation via PROFIBUS PA network

- 1 Automation system
- 2 Computer with PROFIBUS network card
- 3 PROFIBUS DP network
- 4 Segment coupler PROFIBUS DP/PA
- 5 PROFIBUS PA network
- 6 T-box
- 7 Measuring device

Via Modbus RS485 protocol

This communication interface is available in device versions with a Modbus RS485 output.

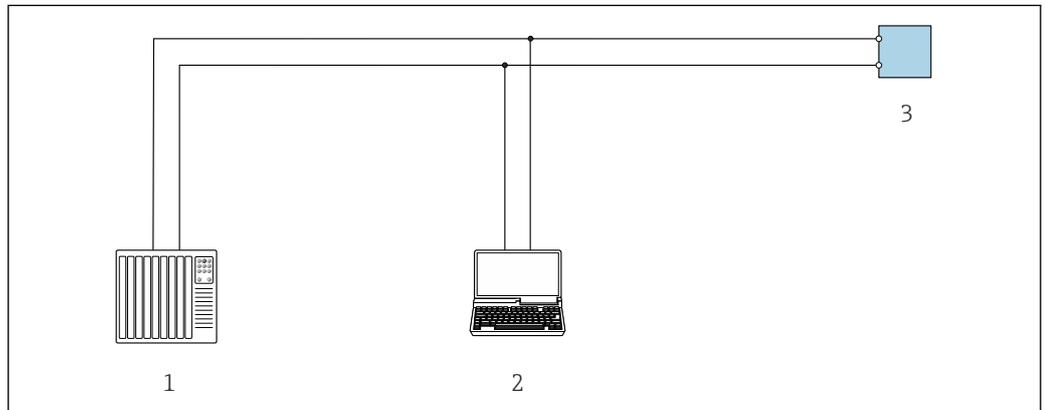

A0029437

78 Options for remote operation via Modbus RS485 protocol (active)

- 1 Control system (e.g. PLC)
- 2 Computer with web browser (e.g. Microsoft Edge) to access the integrated device web server or with operating tool (e.g. FieldCare, DeviceCare) with COM DTM "CDI Communication TCP/IP" or Modbus DTM
- 3 Transmitter

Via EtherNet/IP network

This communication interface is available in device versions with EtherNet/IP.

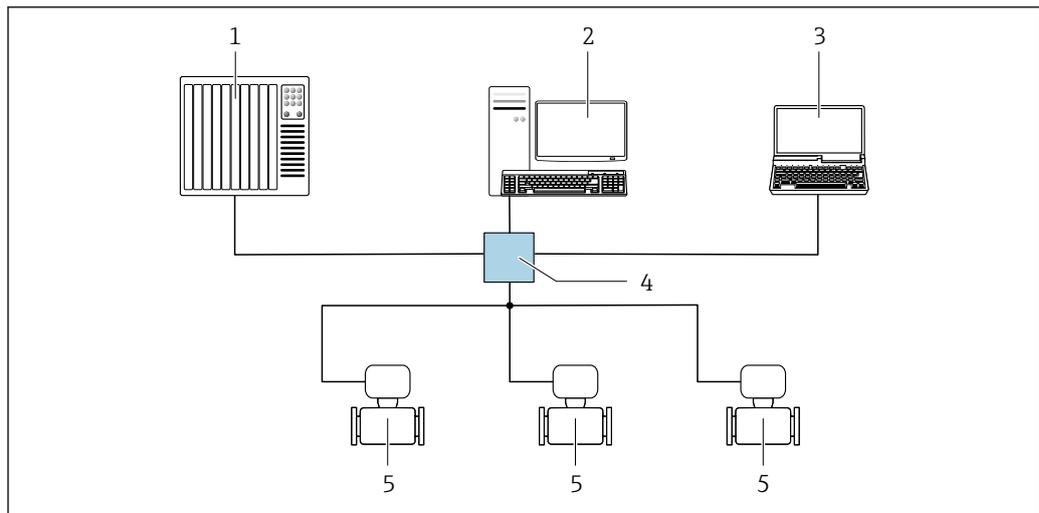
Star topology

A0032078

79 Options for remote operation via EtherNet/IP network: star topology

- 1 Automation system, e.g. "RSLogix" (Rockwell Automation)
- 2 Workstation for measuring device operation: with Custom Add-On Profile for "RSLogix 5000" (Rockwell Automation) or with Electronic Data Sheet (EDS)
- 3 Computer with Web browser (e.g. Internet Explorer) for accessing the integrated Web server or computer with operating tool (e.g. FieldCare, DeviceCare) with COM DTM "CDI Communication TCP/IP"
- 4 Standard Ethernet switch, e.g. Scalance X204 (Siemens)
- 5 Measuring device

Ring topology

The device is integrated via the terminal connection for signal transmission (output 1) and the service interface (CDI-RJ45).

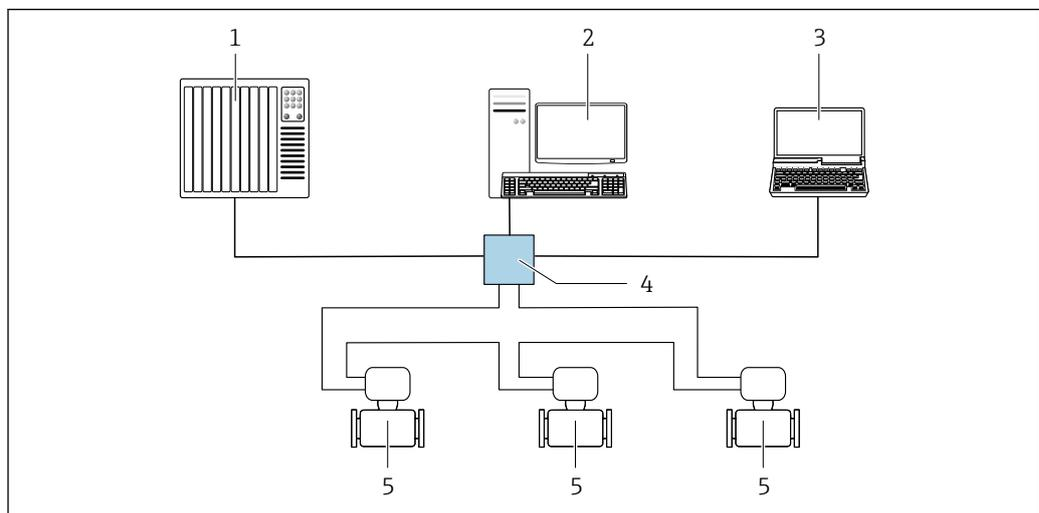

A0033725

80 Options for remote operation via EtherNet/IP network: ring topology

- 1 Automation system, e.g. "RSLogix" (Rockwell Automation)
- 2 Workstation for measuring device operation: with Custom Add-On Profile for "RSLogix 5000" (Rockwell Automation) or with Electronic Data Sheet (EDS)
- 3 Computer with Web browser (e.g. Internet Explorer) for accessing the integrated Web server or computer with operating tool (e.g. FieldCare, DeviceCare) with COM DTM "CDI Communication TCP/IP"
- 4 Standard Ethernet switch, e.g. Scalance X204 (Siemens)
- 5 Measuring device

Via PROFINET network

This communication interface is available in device versions with PROFINET.

Star topology

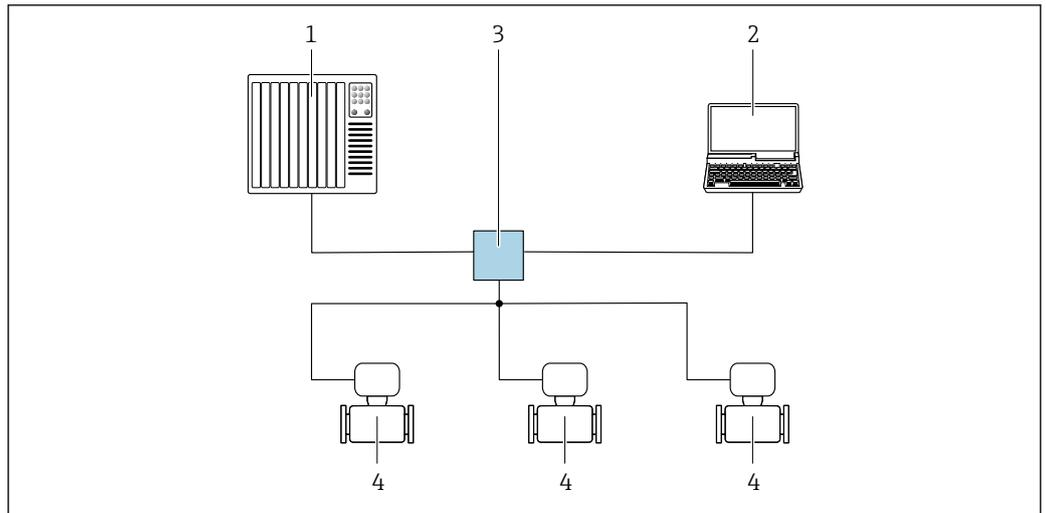

A0026545

81 Options for remote operation via PROFINET network: star topology

- 1 Automation system, e.g. Simatic S7 (Siemens)
- 2 Computer with Web browser (e.g. Internet Explorer) for accessing the integrated Web server or computer with operating tool (e.g. FieldCare, DeviceCare, SIMATIC PDM) with COM DTM "CDI Communication TCP/IP"
- 3 Standard Ethernet switch, e.g. Scalance X204 (Siemens)
- 4 Measuring device

Ring topology

The device is integrated via the terminal connection for signal transmission (output 1) and the service interface (CDI-RJ45).

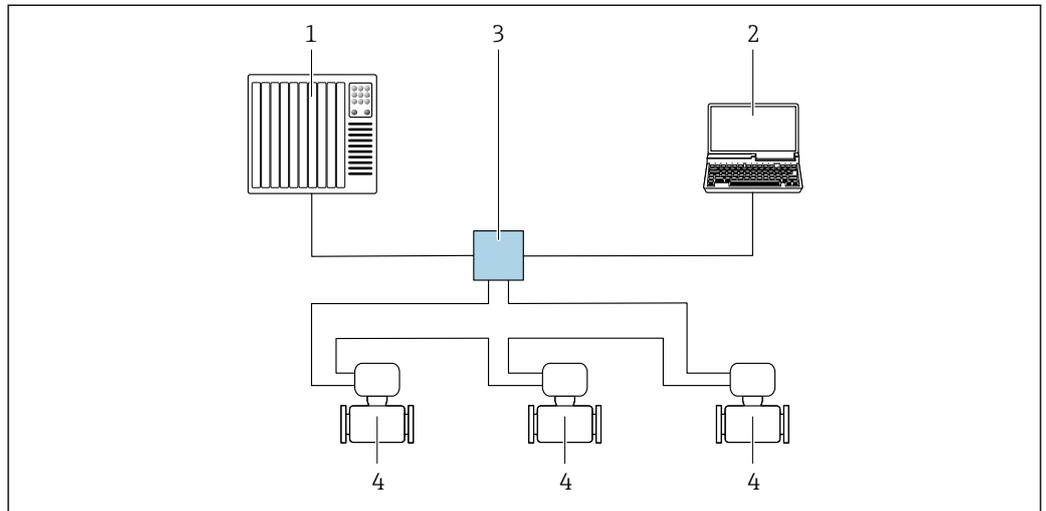

A0033719

82 Options for remote operation via PROFINET network: ring topology

- 1 Automation system, e.g. Simatic S7 (Siemens)
- 2 Computer with Web browser (e.g. Internet Explorer) for accessing the integrated Web server or computer with operating tool (e.g. FieldCare, DeviceCare, SIMATIC PDM) with COM DTM "CDI Communication TCP/IP"
- 3 Standard Ethernet switch, e.g. Scalance X204 (Siemens)
- 4 Measuring device

Via APL network

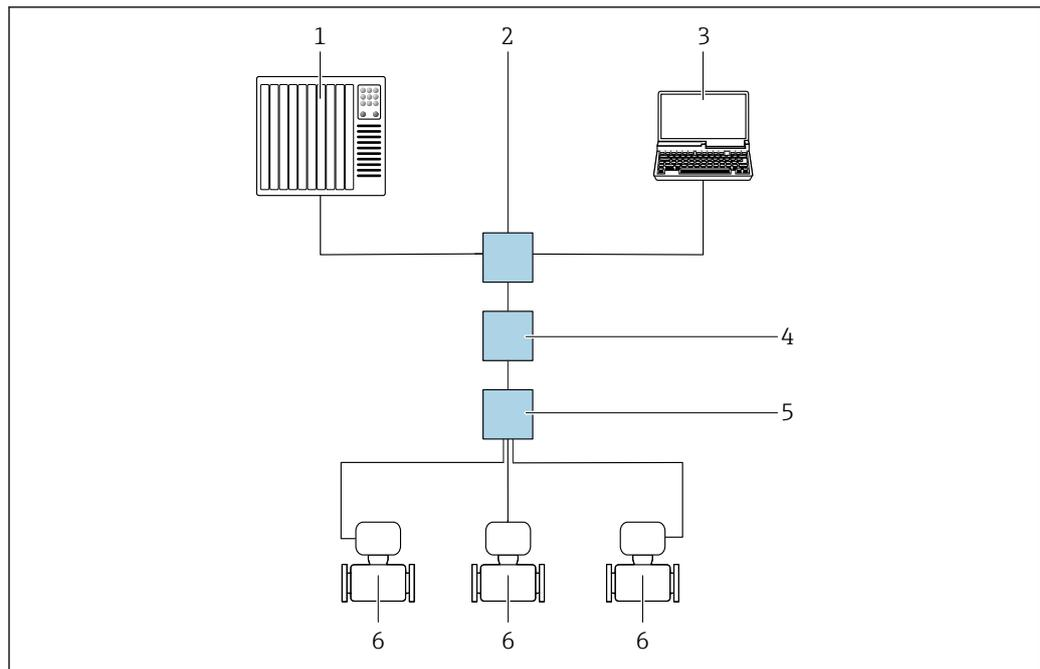

A0046117

 83 Options for remote operation via APL network

- 1 Automation system, e.g. Simatic S7 (Siemens)
- 2 Ethernet switch, e.g. Scalance X204 (Siemens)
- 3 Computer with Web browser (e.g. Internet Explorer) for access to integrated Web server or computer with operating tool (e.g. FieldCare, DeviceCare with PROFINET COM DTM or SIMATIC PDM with FDI-Package)
- 4 APL power switch (optional)
- 5 APL field switch
- 6 Measuring device

Service interface

Via service interface (CDI-RJ45)

A point-to-point connection can be established to configure the device onsite. With the housing open, the connection is established directly via the service interface (CDI-RJ45) of the device.



An adapter for the RJ45 to the M12 plug is optionally available for the non-hazardous area:

Order code for "Accessories", option **NB**: "Adapter RJ45 M12 (service interface)"

The adapter connects the service interface (CDI-RJ45) to an M12 plug mounted in the cable entry. The connection to the service interface can be established via an M12 plug without opening the device.

Proline 500 – digital transmitter

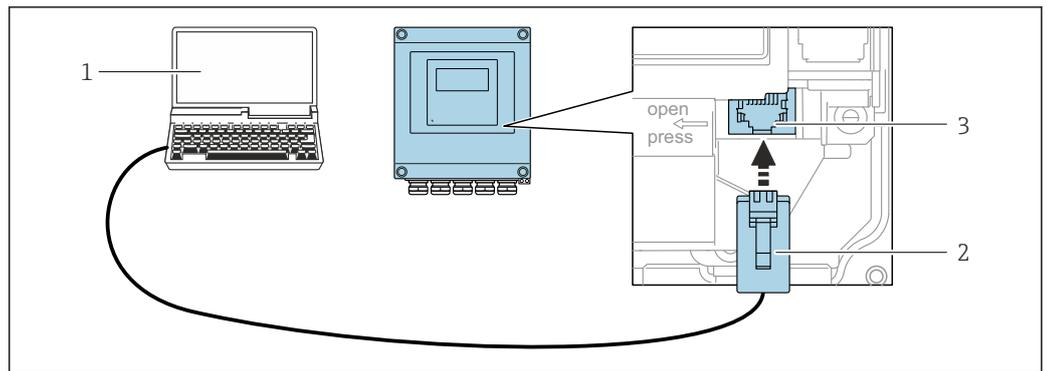

A0029163

84 Connection via service interface (CDI-RJ45)

- 1 Computer with web browser (e.g. Microsoft Internet Explorer, Microsoft Edge) for accessing the integrated web server or with "FieldCare" operating tool, "DeviceCare" with COM DTM "CDI Communication TCP/IP" or Modbus DTM
- 2 Standard Ethernet connecting cable with RJ45 plug
- 3 Service interface (CDI-RJ45) of the measuring device with access to the integrated Web server

Proline 500 transmitter

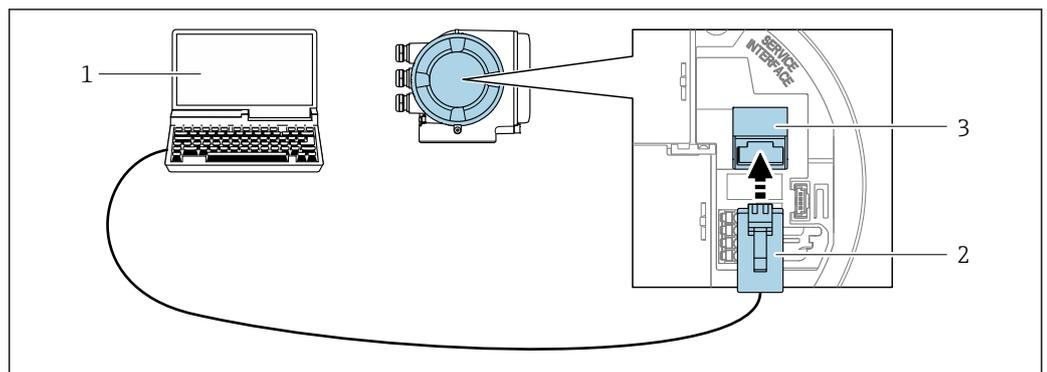

A0027563

85 Connection via service interface (CDI-RJ45)

- 1 Computer with web browser (e.g. Microsoft Internet Explorer, Microsoft Edge) for accessing the integrated web server or with "FieldCare" operating tool, "DeviceCare" with COM DTM "CDI Communication TCP/IP" or Modbus DTM
- 2 Standard Ethernet connecting cable with RJ45 plug
- 3 Service interface (CDI-RJ45) of the measuring device with access to the integrated Web server

Via WLAN interface

The optional WLAN interface is available on the following device version:

Order code for "Display; operation", option G "4-line, illuminated; touch control + WLAN"

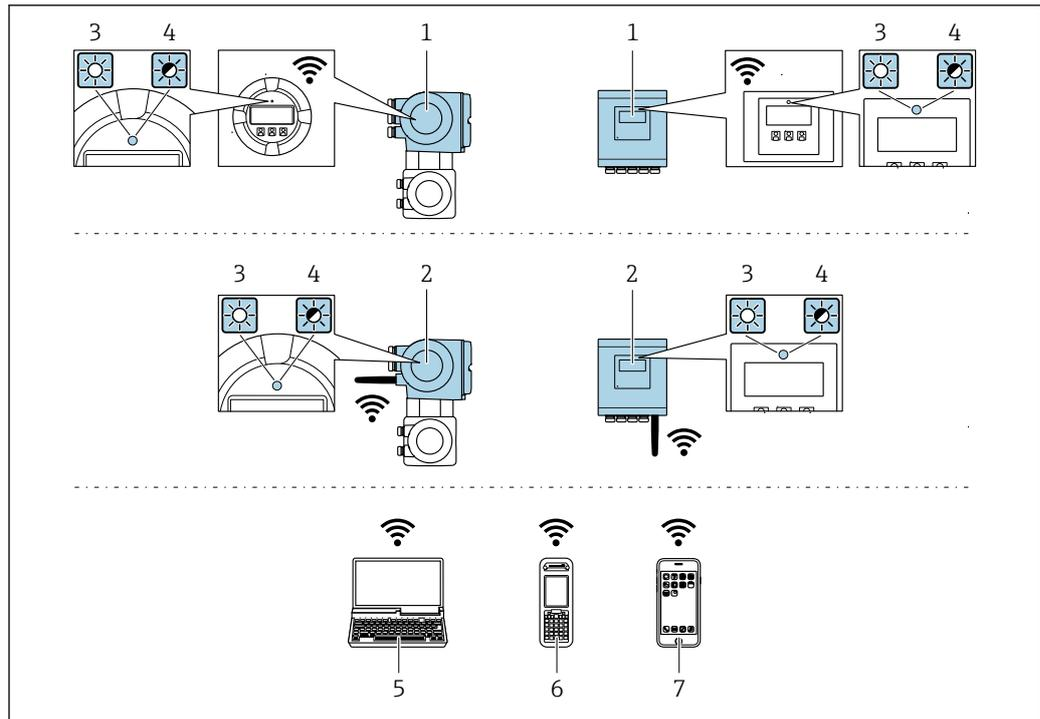

A0034569

- 1 Transmitter with integrated WLAN antenna
- 2 Transmitter with external WLAN antenna
- 3 LED lit constantly: WLAN reception is enabled on measuring device
- 4 LED flashing: WLAN connection established between operating unit and measuring device
- 5 Computer with WLAN interface and web browser (e.g. Microsoft Internet Explorer, Microsoft Edge) for accessing the integrated device web server or with operating tool (e.g. FieldCare, DeviceCare)
- 6 Mobile handheld terminal with WLAN interface and web browser (e.g. Microsoft Internet Explorer, Microsoft Edge) for accessing the integrated device web server or operating tool (e.g. FieldCare, DeviceCare)
- 7 Smart phone or tablet (e.g. Field Xpert SMT70)

Function	WLAN: IEEE 802.11 b/g (2.4 GHz) <ul style="list-style-type: none"> ▪ Access Point with DHCP server (factory setting) ▪ Network
Encryption	WPA2-PSK AES-128 (in accordance with IEEE 802.11i)
Configurable WLAN channels	1 to 11
Degree of protection	IP67
Available antennas	<ul style="list-style-type: none"> ▪ Internal antenna ▪ External antenna (optional) In the event of poor transmission/reception conditions at the place of installation. Available as an accessory → 136. <p> Only 1 antenna is active at any one time!</p>
Range	<ul style="list-style-type: none"> ▪ Internal antenna: typically 10 m (32 ft) ▪ External antenna: typically 50 m (164 ft)
Materials (external antenna)	<ul style="list-style-type: none"> ▪ Antenna: ASA plastic (acrylonitrile styrene acrylate) and nickel-plated brass ▪ Adapter: Stainless steel and nickel-plated brass ▪ Cable: Polyethylene ▪ Plug: Nickel-plated brass ▪ Angle bracket: Stainless steel

Network integration



Network integration is only available for the HART communication protocol.

With the optional "OPC-UA Server" application package, the device can be integrated into an Ethernet network via the service interface (CDI-RJ45 and WLAN) and communicate with OPC-UA clients. If the device is used in this way, IT security must be considered.

i Transmitters with an Ex de approval may **not** be connected via the service interface (CDI-RJ45)!
 Order code for "Approval transmitter + sensor", options (Ex de):
 BB, C2, GB, MB, NB

For permanent access to device data and for device configuration via the Web server, the device is incorporated directly in a network via the service interface (CDI-RJ45). In this way, the device can be accessed any time from the control station. The measured values are processed separately via the inputs and outputs through the automation system.

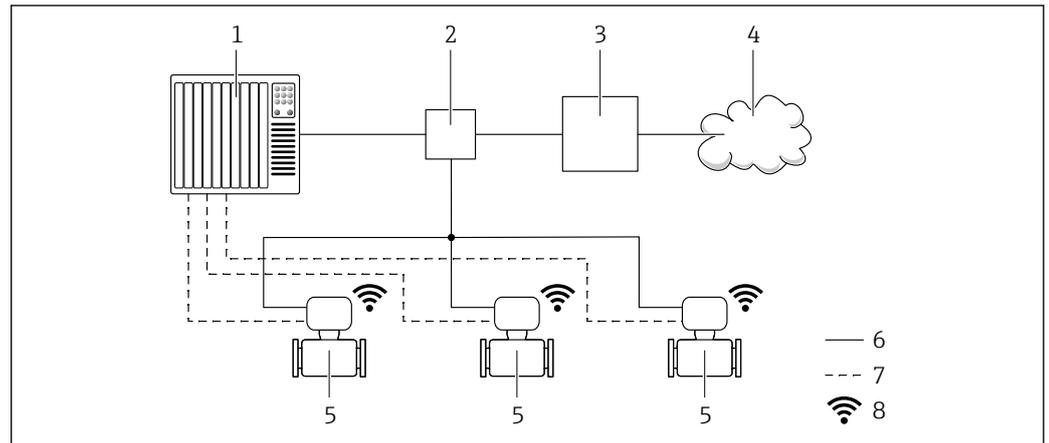

A0033618

- 1 Automation system, e.g. Simatic S7 (Siemens)
- 2 Ethernet switch
- 3 Edge Gateway
- 4 Cloud
- 5 Measuring device
- 6 Ethernet network
- 7 Measured values via inputs and outputs
- 8 Optional WLAN interface

i The optional WLAN interface is available on the following device version:
 Order code for "Display; operation", option G "4-line, backlit, graphic display; touch control + WLAN"

📖 Special Documentation for the OPC-UA Server application package → **📖** 140.

Supported operating tools

Different operating tools can be used for local or remote access to the measuring device. Depending on the operating tool used, access is possible with different operating units and via a variety of interfaces.

Supported operating tools	Operating unit	Interface	Additional information
Web browser	Notebook, PC or tablet with Web browser	<ul style="list-style-type: none"> ■ CDI-RJ45 service interface ■ WLAN interface ■ Ethernet-based fieldbus (EtherNet/IP, PROFINET) 	Special Documentation for device
DeviceCare SFE100	Notebook, PC or tablet with Microsoft Windows system	<ul style="list-style-type: none"> ■ CDI-RJ45 service interface ■ WLAN interface ■ Fieldbus protocol 	→ 📖 138
FieldCare SFE500	Notebook, PC or tablet with Microsoft Windows system	<ul style="list-style-type: none"> ■ CDI-RJ45 service interface ■ WLAN interface ■ Fieldbus protocol 	→ 📖 138

Supported operating tools	Operating unit	Interface	Additional information
Field Xpert	SMT70/77/50	<ul style="list-style-type: none"> ■ All fieldbus protocols ■ WLAN interface ■ Bluetooth ■ CDI-RJ45 service interface 	Operating Instructions BA01202S Device description files: Use update function of handheld terminal
SmartBlue app	Smartphone or tablet with iOS or Android	WLAN	→ 📄 138

 Other operating tools based on FDT technology with a device driver such as DTM/iDTM or DD/EDD can be used for device operation. These operating tools are available from the individual manufacturers. Integration into the following operating tools, among others, is supported:

- FactoryTalk AssetCentre (FTAC) from Rockwell Automation → www.rockwellautomation.com
- Process Device Manager (PDM) from Siemens → www.siemens.com
- Asset Management Solutions (AMS) from Emerson → www.emersonprocess.com
- FieldCommunicator 375/475 from Emerson → www.emersonprocess.com
- Field Device Manager (FDM) from Honeywell → www.process.honeywell.com
- FieldMate from Yokogawa → www.yokogawa.com
- PACTWare → www.pactware.com

The related device description files are available: www.endress.com → Download Area

Web server

With the integrated web server, the device can be operated and configured via a web browser using Ethernet-APL, and via the service interface (CDI-RJ45) or WLAN interface. The structure of the operating menu is the same as for the local display. In addition to the measured values, status information on the device is displayed and can be used to monitor device health. Furthermore the device data can be managed and the network parameters can be configured.

Access to the network is required for the Ethernet-APL connection.

A device that has a WLAN interface (can be ordered as an option) is required for the WLAN connection: order code for "Display; operation", option G "4-line, illuminated; touch control + WLAN". The device acts as an Access Point and enables communication by computer or a mobile handheld terminal.

Supported functions

Data exchange between the operating unit (such as a notebook, for example,) and measuring device:

- Upload the configuration from the measuring device (XML format, configuration backup)
- Save the configuration to the measuring device (XML format, restore configuration)
- Export event list (.csv file)
- Export parameter settings (.csv file or PDF file, document the measuring point configuration)
- Export the Heartbeat verification report (PDF file, only available with the **Heartbeat Verification** → 📄 134 application package)
- Flash firmware version for device firmware upgrade, for example
- Download driver for system integration
- Visualize up to 1000 saved measured values (only available with the **Extended HistoROM** application package → 📄 134)

HistoROM data management

The measuring device features HistoROM data management. HistoROM data management comprises both the storage and import/export of key device and process data, making operation and servicing far more reliable, secure and efficient.

 When the device is delivered, the factory settings of the configuration data are stored as a backup in the device memory. This memory can be overwritten with an updated data record, for example after commissioning.

Additional information on the data storage concept

There are different types of data storage units in which device data are stored and used by the device:

	HistoROM backup	T-DAT	S-DAT
Available data	<ul style="list-style-type: none"> ▪ Event logbook, e.g. diagnostic events ▪ Parameter data record backup ▪ Device firmware package ▪ Driver for system integration for exporting via web server, e.g.: <ul style="list-style-type: none"> ▪ GSD for PROFIBUS DP ▪ GSD for PROFIBUS PA ▪ GSDML for PROFINET ▪ EDS for EtherNet/IP ▪ DD for FOUNDATION Fieldbus 	<ul style="list-style-type: none"> ▪ Measured value logging ("Extended HistoROM" order option) ▪ Current parameter data record (used by firmware at run time) ▪ Indicator (minimum/maximum values) ▪ Totalizer value 	<ul style="list-style-type: none"> ▪ Sensor data: e.g. nominal diameter ▪ Serial number ▪ Calibration data ▪ Device configuration (e.g. SW options, fixed I/O or multi I/O)
Storage location	Fixed on the user interface PC board in the connection compartment	Can be plugged into the user interface PC board in the connection compartment	In the sensor plug in the transmitter neck part

Data backup

Automatic

- The most important device data (sensor and transmitter) are automatically saved in the DAT modules
- If the transmitter or measuring device is replaced: once the T-DAT containing the previous device data has been exchanged, the new measuring device is ready for operation again immediately without any errors
- If the sensor is replaced: once the sensor has been replaced, new sensor data are transferred from the S-DAT in the measuring device and the measuring device is ready for operation again immediately without any errors
- If exchanging the electronics module (e.g. I/O electronics module): Once the electronics module has been replaced, the software of the module is compared against the current device firmware. The module software is upgraded or downgraded where necessary. The electronics module is available for use immediately afterwards and no compatibility problems occur.

Manual

Additional parameter data record (complete parameter settings) in the integrated device memory HistoROM backup for:

- Data backup function
Backup and subsequent restoration of a device configuration in the device memory HistoROM backup
- Data comparison function
Comparison of the current device configuration with the device configuration saved in the device memory HistoROM backup

Data transmission

Manual

- Transfer of a device configuration to another device using the export function of the specific operating tool, e.g. with FieldCare, DeviceCare or Web server: to duplicate the configuration or to store in an archive (e.g. for backup purposes)
- Transmission of the drivers for system integration via Web server, e.g.:
 - GSD for PROFIBUS DP
 - GSD for PROFIBUS PA
 - GSDML for PROFINET
 - EDS for EtherNet/IP
 - DD for FOUNDATION Fieldbus

Event list

Automatic

- Chronological display of up to 20 event messages in the events list
- If the **Extended HistoROM** application package (order option) is enabled: up to 100 event messages are displayed in the events list along with a time stamp, plain text description and remedial measures
- The events list can be exported and displayed via a variety of interfaces and operating tools e.g. DeviceCare, FieldCare or Web server

Data logging**Manual**

If the **Extended HistoROM** application package (order option) is enabled:

- Recording of 1 to 4 channels of up to 1 000 measured values (up to 250 measured values per channel)
- User configurable recording interval
- Export the measured value log via a variety of interfaces and operating tools e.g. FieldCare, DeviceCare or web server

Certificates and approvals

Current certificates and approvals for the product are available at www.endress.com on the relevant product page:

1. Select the product using the filters and search field.
2. Open the product page.
3. Select **Downloads**.

CE mark

The device meets the legal requirements of the applicable EU Directives. These are listed in the corresponding EU Declaration of Conformity along with the standards applied.

Endress+Hauser confirms successful testing of the device by affixing to it the CE mark.

UKCA marking

The device meets the legal requirements of the applicable UK regulations (Statutory Instruments). These are listed in the UKCA Declaration of Conformity along with the designated standards. By selecting the order option for UKCA marking, Endress+Hauser confirms a successful evaluation and testing of the device by affixing the UKCA mark.

Contact address Endress+Hauser UK:

Endress+Hauser Ltd.
Floats Road
Manchester M23 9NF
United Kingdom
www.uk.endress.com

RCM marking

The measuring system meets the EMC requirements of the "Australian Communications and Media Authority (ACMA)".

Ex approval

The measuring device is certified for use in hazardous areas and the relevant safety instructions are provided in the separate "Safety Instructions" (XA) document. Reference is made to this document on the nameplate.

 The separate Ex documentation (XA) containing all the relevant explosion protection data is available from your Endress+Hauser sales center.

Proline 500 – digital

ATEX, IECEx

Currently, the following versions for use in hazardous areas are available:

Ex ia, Ex db

Transmitter		Sensor	
Category	Type of protection	Category	Type of protection
II(1)G	[Ex ia] IIC	II2G	Ex db ia IIC T6...T1 Gb
II3(1)G	Ex ec [ia Ga] IIC T5...T4 Gc	II2G	Ex db ia IIC T6...T1 Gb

Ex tb

Transmitter		Sensor	
Category	Type of protection	Category	Type of protection
II(1)D	[Ex ia] IIIC	II2D	Ex ia tb IIIC T** °C Db

Non-Ex, Ex ec

Transmitter		Sensor	
Category	Type of protection	Category	Type of protection
Non-Ex	Non-Ex	II3G	Ex ec ic IIC T5...T1 Gc
II3G	Ex ec IIC T5...T4 Gc	II3G	Ex ec ic IIC T5...T1 Gc

cCSAus

Currently, the following versions for use in hazardous areas are available:

IS (Ex nA, Ex i)

Transmitter	Sensor
Class I Division 2 Groups A - D	Class I, II, III Division 1 Groups A-G

NI (Ex nA)

Transmitter	Sensor
Class I Division 2 Groups A - D	

Ex nA, Ex i

Transmitter	Sensor
Class I, Zone 2 AEx/ Ex nA [ia Ga] IIC T5...T4 Gb	Class I, Zone 1 AEx/ Ex d ia IIC T6...T1 Gb

Ex nA

Transmitter	Sensor
Class I, Zone 2 AEx/ Ex nA IIC T5...T4 Gc	Class I, Zone 2 AEx/Ex nA ic IIC T5...T1 Gc

Ex tb

Transmitter	Sensor
[AEx / Ex ia] IIIC	Zone 21 AEx/ Ex ia tb IIIC T** °C Db

Proline 500

ATEX, IECEx

Currently, the following versions for use in hazardous areas are available:

Ex db eb

Category	Type of protection	
	Transmitter	Sensor
II2G	Ex db eb ia IIC T6...T4 Gb	Ex eb ia IIC T6...T1 Gb

Ex db

Category	Type of protection	
	Transmitter	Sensor
II2G	Ex db ia IIC T6...T4 Gb	Ex eb ia IIC T6...T1 Gb

Ex tb

Category	Type of protection	
	Transmitter	Sensor
II2G	Ex tb IIIC T85°C Db	Ex ia tb IIIC T** °C Db

Ex ec

Category	Type of protection	
	Transmitter	Sensor
II3G	Ex ec IIC T5...T4 Gc	Ex ec ic IIC T5...T1 Gc

cCSAus

Currently, the following versions for use in hazardous areas are available:

IS (Ex i), XP (Ex d)

Transmitter	Sensor
Class I, II, III Division 1 Groups A-G	

NI (Ex nA)

Transmitter	Sensor
Class I Division 2 Groups A - D	

Ex de

Transmitter	Sensor
Class I, Zone 1 AEx/ Ex de ia IIC T6...T4 Gb	Class I, Zone 1 AEx/Ex e ia IIC T6...T1 Gb

Ex d

Transmitter	Sensor
Class I, Zone 1 AEx/ Ex d ia IIC T6...T4 Gb	Class I, Zone 1 AEx/Ex e ia IIC T6...T1 Gb

Ex nA

Transmitter	Sensor
Class I, Zone 2 AEx/ Ex nA IIC T5...T4 Gc	Class I, Zone 2 AEx/Ex nA ic IIC T5...T1 Gc

Ex tb

Transmitter	Sensor
Zone 21 AEx/ Ex tb IIIC T85 °C Db	Zone 21 AEx/ Ex ia tb IIIC T** °C Db

Sanitary compatibility

- 3-A SSI 28-06 or more recent
 - Confirmation by affixing the 3-A logo for measuring devices with the order code for "Additional approval", option LP "3-A".
 - The 3-A approval refers to the measuring device.
 - When installing the measuring device, ensure that no liquid can accumulate on the outside of the measuring device.
Remote transmitters must be installed in accordance with the 3-A Standard.
 - Accessories (e.g. weather protection cover, wall holder unit) must be installed in accordance with the 3-A Standard.
Each accessory can be cleaned. Disassembly may be necessary under certain circumstances.
- EHEDG Type EL Class I
 - Confirmation by affixing the EHEDG symbol for measuring devices with the order code for "Additional approval", option LT "EHEDG".
 - EPDM is not a suitable seal material for fluids with a fat content > 8 %.
 - To meet the requirements for EHEDG certification, the device must be used with process connections in accordance with the EHEDG position paper entitled "Easy Cleanable Pipe Couplings and Process Connections" (www.ehedg.org).
- FDA 21 CFR 177
- Food Contact Materials Regulation (EC) 1935/2004
- Food Contact Materials Regulation China GB 4806
- Pasteurized Milk Ordinance (PMO)

Pharmaceutical compatibility

- FDA 21 CFR 177
- USP <87>
- USP <88> Class VI 121 °C
- TSE/BSE Certificate of Suitability
- cGMP
Devices with the order code for "Test, certificate", option JG "Conformity with cGMP-derived requirements, declaration" comply with the requirements of cGMP with regard to the surfaces of parts in contact with the medium, design, FDA 21 CFR material conformity, USP Class VI tests and TSE/BSE conformity.
A serial number-specific declaration is generated.

Functional safety

The measuring instrument can be used for flow monitoring systems (min., max., range) up to SIL 2 (single-channel architecture; order code for "Additional approval", option LA) and SIL 3 (multi-channel architecture with homogeneous redundancy) and is independently evaluated and certified in accordance with IEC 61508.

The following types of monitoring in safety-related systems are possible:

Restrictions

- Valid single gases:
 - Air
 - Methane (CH₄)
 - Carbon dioxide CO₂
 - Nitrogen (N₂)
 - Oxygen (O₂)
- Valid 4-component natural gas composition in mol%:
 - CH₄ 80 to 99 %
 - N₂ 0.3 to 12 %
 - C₂H₆ 0.3 to 12 %
 - CO₂ 0.3 to 12 %
- Extended natural gas range I: The listed 4-component natural gas composition may be extended by a selection of the following components up to a maximum proportion according to the following table:

Additional natural gas components	Max. mol%
Propane (C ₃ H ₈)	2 %
Butane (i-C ₄ H ₁₀ , n-C ₄ H ₁₀)	1 %
Pentane (i-C ₅ H ₁₂ , n-C ₅ H ₁₂)	0.2 %
Hexane (i-C ₆ H ₁₄ , n-C ₆ H ₁₄)	0.2 %
Oxygen (O ₂)	0.2 %

- Extended natural gas range II: Natural gas mixtures that correspond to the 4-component natural gas composition or extended natural gas range I, with CO₂ and/or N₂ proportions of less than 0.3 mol% each (as defined in the 4-component mixture) are possible, taking into account the special configuration instructions in "Configuring the extended natural gas range".
- Temperature range: -30 to +150 °C (-22 to +302 °F)
- Pressure range: 0.8 to 30 bar (11.6 to 435 psi)
- Nominal diameters: Up to 320 mm (12.6 in) internal diameter
- Circular pipe for insertion version (cannot be used in rectangular ducts)
- The maximum flow rate during operation must not exceed the specified calibrated maximum value for the sensor.
- Measurement uncertainty in the SIL mode (see "Guidelines for minimum measurement error" in the Special Documentation for Functional Safety).



Functional safety manual with information for the SIL device → 140

HART certification

HART interface

The measuring device is certified and registered by the FieldComm Group. The measuring system meets all the requirements of the following specifications:

- Certified according to HART 7
- The device can also be operated with certified devices of other manufacturers (interoperability)

FOUNDATION Fieldbus certification

FOUNDATION Fieldbus interface

The measuring device is certified and registered by the FieldComm Group. The measuring system meets all the requirements of the following specifications:

- Certified in accordance with FOUNDATION Fieldbus H1
- Interoperability Test Kit (ITK), revision version 6.2.0 (certificate available on request)
- Physical Layer Conformance Test
- The device can also be operated with certified devices of other manufacturers (interoperability)

Certification PROFIBUS

PROFIBUS interface

The measuring device is certified and registered by the PNO (PROFIBUS Nutzerorganisation e.V. / PROFIBUS User Organization). The measuring system meets all the requirements of the following specifications:

- Certified according to PA Profile 3.02
- The device can also be operated with certified devices of other manufacturers (interoperability)

EtherNet/IP certification

The measuring device is certified and registered by the ODVA (Open Device Vendor Association). The measuring system meets all the requirements of the following specifications:

- Certified in accordance with the ODVA Conformance Test
- EtherNet/IP Performance Test
- EtherNet/IP PlugFest compliance
- The device can also be operated with certified devices of other manufacturers (interoperability)

Certification PROFINET

PROFINET interface

The measuring device is certified and registered by the PNO (PROFIBUS Nutzerorganisation e.V. / PROFIBUS User Organization). The measuring system meets all the requirements of the following specifications:

- Certified according to:
 - Test specification for PROFINET devices
 - PROFINET Security Level 2- Netload Class 2 0 Mbps
- The device can also be operated with certified devices of other manufacturers (interoperability)
- The device supports PROFINET S2 system redundancy.

PROFINET with Ethernet-APL certification**PROFINET interface**

The measuring device is certified and registered by the PNO (PROFIBUS Nutzerorganisation e. V./ PROFIBUS User Organization). The measuring system meets all the requirements of the following specifications:

- Certified according to:
 - Test specification for PROFINET devices
 - PROFINET PA Profile 4
 - PROFINET netload robustness Class 2 10 Mbit/s
 - APL conformance test
- The device can also be operated with certified devices of other manufacturers (interoperability)
- The device supports PROFINET S2 system redundancy.

Radio approval

The measuring device has radio approval.



For detailed information on the radio approval, see the Special Documentation

Pressure Equipment Directive

The measuring devices can be ordered with or without PED or PESR. If a device with PED or PESR is required, this must be ordered explicitly. For devices with nominal diameters less than or equal to DN 25 (1"), this is neither possible nor necessary. A UK order option must be selected for PESR under the order code for "Approvals".

- With the marking
 - a) PED/G1/x (x = category) or
 - b) PESR/G1/x (x = category)
 on the sensor nameplate, Endress+Hauser confirms compliance with the "Essential Safety Requirements"
 - a) specified in Annex I of the Pressure Equipment Directive 2014/68/EU or
 - b) Schedule 2 of Statutory Instruments 2016 No. 1105.
- Devices bearing this marking (PED or PESR) are suitable for the following types of medium: Media in Group 1 and 2 with a vapor pressure greater than, or smaller and equal to 0.5 bar (7.3 psi)
- Devices not bearing this marking (without PED or PESR) are designed and manufactured according to sound engineering practice. They meet the requirements of
 - a) Art. 4 Para. 3 of the Pressure Equipment Directive 2014/68/EU or
 - b) Part 1, Para. 8 of Statutory Instruments 2016 No. 1105.
 The scope of application is indicated
 - a) in diagrams 6 to 9 in Annex II of the Pressure Equipment Directive 2014/68/EU or
 - b) Schedule 3, Para. 2 of Statutory Instruments 2016 No. 1105.

Additional certification**PWIS-free**

PWIS = paint-wetting impairment substances

Order code for "Service":

- Option **HC**: PWIS-free (version A)
- Option **HD**: PWIS-free (version B)
- Option **HE**: PWIS-free (version C)



For more information on PWIS-free certification, see "Test specification" document TS01028D

External standards and guidelines

- EN 60529
Degrees of protection provided by enclosures (IP code)
- EN 61010-1
Safety requirements for electrical equipment for measurement, control and laboratory use - general requirements
- EN 61326-1/-2-3
EMC requirements for electrical equipment for measurement, control and laboratory use
- NAMUR NE 21
Electromagnetic compatibility (EMC) of industrial process and laboratory control equipment
- NAMUR NE 32
Data retention in the event of a power failure in field and control instruments with microprocessors
- NAMUR NE 43
Standardization of the signal level for the breakdown information of digital transmitters with analog output signal.

- NAMUR NE 53
Software of field devices and signal-processing devices with digital electronics
- NAMUR NE 105
Specifications for integrating fieldbus devices in engineering tools for field devices
- NAMUR NE 107
Self-monitoring and diagnosis of field devices
- NAMUR NE 131
Requirements for field devices for standard applications
- ETSI EN 300 328
Guidelines for 2.4 GHz radio components.
- EN 301489
Electromagnetic compatibility and radio spectrum matters (ERM).

Ordering information

Detailed ordering information is available from your nearest sales organization www.addresses.endress.com or in the Product Configurator at www.endress.com:

1. Select the product using the filters and search field.
2. Open the product page.
3. Select **Configuration**.

Product Configurator - the tool for individual product configuration

- Up-to-the-minute configuration data
- Depending on the device: Direct input of measuring point-specific information such as measuring range or operating language
- Automatic verification of exclusion criteria
- Automatic creation of the order code and its breakdown in PDF or Excel output format
- Ability to order directly in the Endress+Hauser Online Shop

Application packages

Many different application packages are available to enhance the functionality of the device. Such packages might be needed to address safety aspects or specific application requirements.

The application packages can be ordered with the device or subsequently from Endress+Hauser. Detailed information on the order code in question is available from your local Endress+Hauser sales center or on the product page of the Endress+Hauser website: www.endress.com.

Diagnostic functionality

Order code for "Application package", option EA "Extended HistoROM"

Comprises extended functions concerning the event log and the activation of the measured value memory.

Event log:

Memory volume is extended from 20 message entries (standard version) to up to 100 entries.

Data logging (line recorder):

- Memory capacity for up to 1000 measured values is activated.
- 250 measured values can be output via each of the 4 memory channels. The recording interval can be defined and configured by the user.
- Measured value logs can be accessed via the local display or operating tool e.g. FieldCare, DeviceCare or Web server.



For detailed information, see the Operating Instructions for the device.

Heartbeat Technology

Order code for "Application package", option EB "Heartbeat Verification + Monitoring"

Heartbeat Verification

Meets the requirement for traceable verification to DIN ISO 9001:2008 Chapter 7.6 a) "Control of monitoring and measuring equipment".

- Functional testing in the installed state without interrupting the process.
- Traceable verification results on request, including a report.
- Simple testing process via local operation or other operating interfaces.
- Clear measuring point assessment (pass/fail) with high test coverage within the framework of manufacturer specifications.
- Extension of calibration intervals according to operator's risk assessment.

Heartbeat Monitoring

Continuously supplies data, which are characteristic of the measuring principle, to an external condition monitoring system for the purpose of preventive maintenance or process analysis. These data enable the operator to:

- Draw conclusions - using these data and other information - about the impact process influences (e.g. buildup, interference from the magnetic field) have on the measuring performance over time.
- Schedule servicing in time.
- Monitor the process or product quality .



For detailed information, see the Special Documentation for the device.

Cleaning

Order code for "Application package", option EC "ECC electrode cleaning "

The electrode cleaning circuit (ECC) function has been developed to have a solution for applications where magnetite (Fe_3O_4) deposits frequently occur (e.g. hot water). Since magnetite is highly conductive this build up leads to measuring errors and ultimately to the loss of signal. The application package is designed to avoid build-up of very conductive matter and thin layers (typical of magnetite).



For detailed information, see the Operating Instructions for the device.

OPC-UA Server

Order code for "Application package", option EL "OPC-UA Server"

The application package provides an integrated OPC-UA server for comprehensive device services for IoT and SCADA applications.



For detailed information, see the Special Documentation for the device.

Accessories

Various accessories, which can be ordered with the device or subsequently from Endress+Hauser, are available for the device. Detailed information on the order code in question is available from your local Endress+Hauser sales center or on the product page of the Endress+Hauser website: www.endress.com.

Device-specific accessories

For the transmitter

Accessories	Description
Transmitter <ul style="list-style-type: none"> ▪ Proline 500 – digital ▪ Proline 500 	Transmitter for replacement or storage. Use the order code to define the following specifications: <ul style="list-style-type: none"> ▪ Approvals ▪ Output ▪ Input ▪ Display/operation ▪ Housing ▪ Software <p> <ul style="list-style-type: none"> ▪ Proline 500 – digital transmitter: Order number: 5X5BXX-*****A ▪ Proline 500 transmitter: Order number: 5X5BXX-*****B </p> <p> Proline 500 transmitter for replacement: It is essential to specify the serial number of the current transmitter when ordering. On the basis of the serial number, the device-specific data (e.g. calibration factors) of the replaced device can be used for the new transmitter.</p> <p> <ul style="list-style-type: none"> ▪ Proline 500 – digital transmitter: Installation Instructions EA01151D ▪ Proline 500 transmitter: Installation Instructions EA01152D </p>
External WLAN antenna	External WLAN antenna with 1.5 m (59.1 in) connecting cable and two angle brackets. Order code for "Accessory enclosed", option P8 "Wireless antenna wide area". <ul style="list-style-type: none">  <ul style="list-style-type: none"> ▪ The external WLAN antenna is not suitable for use in hygienic applications. ▪ Additional information regarding the WLAN interface →  123.  Order number: 71351317  Installation Instructions EA01238D
Pipe mounting set	Pipe mounting set for transmitter. <ul style="list-style-type: none">  Proline 500 – digital transmitter Order number: 71346427  Installation Instructions EA01195D  Proline 500 transmitter Order number: 71346428
Weather protection cover Transmitter <ul style="list-style-type: none"> ▪ Proline 500 – digital ▪ Proline 500 	Is used to protect the measuring device from the effects of the weather: e.g. rainwater, excess heating from direct sunlight. <ul style="list-style-type: none">  <ul style="list-style-type: none"> ▪ Proline 500 – digital transmitter Order number: 71343504 ▪ Proline 500 transmitter Order number: 71343505  Installation Instructions EA01191D
Display guard Proline 500 – digital	Is used to protect the display against impact or scoring, for example from sand in desert areas. <ul style="list-style-type: none">  Order number: 71228792  Installation Instructions EA01093D

Connecting cable Proline 500 – digital Sensor – Transmitter	<p>The connecting cable can be ordered directly with the measuring device (order code for "Cable, sensor connection) or as an accessory (order number DK5012).</p> <p>The following cable lengths are available: order code for "Cable, sensor connection"</p> <ul style="list-style-type: none"> ▪ Option B: 20 m (65 ft) ▪ Option E: User-configurable up to max. 50 m ▪ Option F: User-configurable up to max. 165 ft <p> Maximum possible cable length for a Proline 500 – digital connecting cable: 300 m (1000 ft)</p>
Connecting cables Proline 500 Sensor – Transmitter	<p>The connecting cable can be ordered directly with the measuring device (order code for "Cable, sensor connection") or as an accessory (order number DK5012).</p> <p>The following cable lengths are available: order code for "Cable, sensor connection"</p> <ul style="list-style-type: none"> ▪ Option 1: 5 m (16 ft) ▪ Option 2: 10 m (32 ft) ▪ Option 3: 20 m (65 ft) ▪ Option 4: User-configurable cable length (m) ▪ Option 5: User-configurable cable length (ft) <p> Possible cable length for a Proline 500 connecting cable: depending on the medium conductivity, max. 200 m (660 ft)</p>

For the sensor

Accessories	Description
Adapter set	<p>Adapter connections for installing a Promag H instead of a Promag 30/33 A or Promag 30/33 H (DN 25).</p> <p>Consists of:</p> <ul style="list-style-type: none"> ▪ 2 process connections ▪ Screws ▪ Seals
Seal set	For the regular replacement of seals for the sensor.
Spacer	If replacing a DN 80/100 sensor in an existing installation, a spacer is needed if the new sensor is shorter.
Welding jig	Welding socket as process connection: welding jig for installation in pipe.
Grounding rings	<p>Are used to ground the medium in lined measuring tubes to ensure proper measurement.</p> <p> Grounding rings can be ordered via the device order structure or configured and ordered as an accessory via the DK5HR order structure.</p>
Ground disks	<p>Are used to ground the medium in lined measuring tubes to ensure proper measurement.</p> <p> For details, see Installation Instructions EA00070D</p>
Mounting kit	<p>Consists of:</p> <ul style="list-style-type: none"> ▪ 2 process connections ▪ Screws ▪ Seals
Wall mounting kit	Wall mounting kit for measuring device (only DN 2 to 25 (1/12 to 1"))

Communication-specific accessories

Accessories	Description
Commubox FXA195 HART	<p>For intrinsically safe HART communication with FieldCare via the USB port</p> <p> Technical Information TI00404F</p>
HART Loop Converter HMX50	<p>Is used to evaluate and convert dynamic HART process variables to analog current signals or limit values.</p> <p> <ul style="list-style-type: none"> ▪ Technical Information TI00429F ▪ Operating Instructions BA00371F </p>

Fieldgate FXA42	<p>Transmission of the measured values of connected 4 to 20 mA analog measuring devices, as well as digital measuring devices</p> <ul style="list-style-type: none">  Technical Information TI01297S  Operating Instructions BA01778S  Product page: www.endress.com/fxa42
Field Xpert SMT50	<p>The Field Xpert SMT50 tablet PC for device configuration enables mobile plant asset management. It is suitable for commissioning and maintenance staff to manage field instruments with a digital communication interface and to record progress. This tablet PC is designed as an all-in-one solution with a preinstalled driver library and is an easy-to-use, touch-sensitive tool which can be used to manage field instruments throughout their entire life cycle.</p> <ul style="list-style-type: none">  Technical Information TI01555S  Operating Instructions BA02053S  Product page: www.endress.com/smt50
Field Xpert SMT70	<p>The Field Xpert SMT70 tablet PC for device configuration enables mobile plant asset management in hazardous and non-hazardous areas. It is suitable for commissioning and maintenance staff to manage field instruments with a digital communication interface and to record progress. This tablet PC is designed as an all-in-one solution with a preinstalled driver library and is an easy-to-use, touch-sensitive tool which can be used to manage field instruments throughout their entire life cycle.</p> <ul style="list-style-type: none">  Technical Information TI01342S  Operating Instructions BA01709S  Product page: www.endress.com/smt70
Field Xpert SMT77	<p>The Field Xpert SMT77 tablet PC for device configuration enables mobile plant asset management in areas categorized as Ex Zone 1.</p> <ul style="list-style-type: none">  Technical Information TI01418S  Operating Instructions BA01923S  Product page: www.endress.com/smt77

Service-specific accessories

Accessories	Description
Applicator	<p>Software for selecting and sizing Endress+Hauser measuring devices:</p> <ul style="list-style-type: none">  Choice of measuring devices for industrial requirements  Calculation of all the necessary data for identifying the optimum flowmeter: e.g. nominal diameter, pressure loss, flow velocity and accuracy.  Graphic illustration of the calculation results  Determination of the partial order code, administration, documentation and access to all project-related data and parameters over the entire life cycle of a project. <p>Applicator is available:</p> <ul style="list-style-type: none">  Via the Internet: https://portal.endress.com/webapp/applicator  As a downloadable DVD for local PC installation.
Netilion	<p>IIoT ecosystem: Unlock knowledge</p> <p>Endress+Hauser's Netilion IIoT ecosystem enables you to optimize your plant performance, digitize workflows, share knowledge and improve collaboration. Based on decades of experience in process automation, Endress+Hauser offers the process industry an IIoT ecosystem that enables you to gain useful insights from data. This knowledge can be used to optimize processes, leading to higher plant availability, efficiency and reliability, and ultimately to a more profitable plant.</p> <p>www.netilion.endress.com</p>
FieldCare	<p>FDT-based plant asset management tool from Endress+Hauser. It can configure all smart field units in your system and helps you manage them. By using the status information, it is also a simple but effective way of checking their status and condition.</p> <ul style="list-style-type: none">  Operating Instructions BA00027S and BA00059S
DeviceCare	<p>Tool to connect and configure Endress+Hauser field devices.</p> <ul style="list-style-type: none">  Innovation brochure IN01047S

System components	Accessories	Description
	Memograph M graphic data manager	The Memograph M graphic data manager provides information on all the relevant measured variables. Measured values are recorded correctly, limit values are monitored and measuring points analyzed. The data are stored in the 256 MB internal memory and also on a SD card or USB stick.  <ul style="list-style-type: none"> ▪ Technical Information TI00133R ▪ Operating Instructions BA00247R
	iTEMP	The temperature transmitters can be used in all applications and are suitable for the measurement of gases, steam and liquids. They can be used to read in the medium temperature.  "Fields of Activity" document FA00006T

Supplementary documentation

-  For an overview of the scope of the associated Technical Documentation, refer to the following:
- *Device Viewer* (www.endress.com/deviceviewer): Enter the serial number from the nameplate
 - *Endress+Hauser Operations app*: Enter serial number from nameplate or scan matrix code on nameplate.

Standard documentation

-  Supplementary information on the semi-standard options is available in the relevant Special Documentation in the TSP database.

Brief Operating Instructions

Brief Operating Instructions for the sensor

Measuring device	Documentation code
Proline Promag H	KA01289D

Brief Operating Instructions for the transmitter

Measuring device	Documentation code							PROFINET with Ethernet-APL
	HART	FOUNDATION Fieldbus	PROFIBUS PA	PROFIBUS DP	Modbus RS485	EtherNet/IP	PROFINET	
Proline 500 – digital	KA01313D	KA01292D	KA01407D	KA01388D	KA01317D	KA01343D	KA01349D	KA01519D
Proline 500	KA01312D	KA01293D	KA01406D	KA01387D	KA01316D	KA01342D	KA01348D	KA01518D

Operating Instructions

Measuring device	Documentation code							PROFINET with Ethernet-APL
	HART	FOUNDATION Fieldbus	PROFIBUS PA	PROFIBUS DP	Modbus RS485	EtherNet/IP	PROFINET	
Promag H 500	BA01398D	BA01479D	BA01404D	BA01866D	BA01401D	BA01720D	BA01723D	BA02103D

Description of Device Parameters

Measuring device	Documentation code							
	HART	FOUNDATION Fieldbus	PROFIBUS PA	PROFIBUS DP	Modbus RS485	EtherNet/IP	PROFINET	PROFINET with Ethernet-APL
Promag 500	GP01054D	GP01099D	GP01056D	GP01136D	GP01055D	GP01118D	GP01119D	GP01169D

Supplementary device-dependent documentation

Safety instructions

Safety instructions for electrical equipment for hazardous areas.

Contents	Documentation code
ATEX/IECEX Ex i	XA01522D
ATEX/IECEX Ex ec	XA01523D
cCSAus IS	XA01524D
cCSAus Ex e ia/Ex d ia	XA01525D
cCSAus Ex nA	XA01526D
INMETRO Ex i	XA01527D
INMETRO Ex ec	XA01528D
NEPSI Ex i	XA01529D
NEPSI Ex nA	XA01530D
EAC Ex i	XA01658D
EAC Ex nA	XA01659D
JPN	XA01776D

Functional Safety Manual

Contents	Documentation code
Promag 500	SD01741D

Special Documentation

Contents	Documentation code
Information on the Pressure Equipment Directive	SD01614D
Radio approvals for WLAN interface for A309/A310 display module	SD01793D
OPC-UA server ¹⁾	SD02044D

1) This Special Documentation is only available for device versions with a HART output.

Contents	Documentation code							
	HART	FOUNDATION Fieldbus	PROFIBUS PA	PROFIBUS DP	Modbus RS485	PROFINET	EtherNet/IP	PROFINET with Ethernet-APL
Heartbeat Technology	SD01641D	SD01745D	SD01747D	SD02207D	SD01746D	SD01987D	SD01981D	SD02730D
Web server	SD01658D	SD01661D	SD01660D	SD02236D	SD01659D	SD01979D	SD01978D	SD02760D

Installation instructions

Contents	Note
Installation instructions for spare part sets and accessories	Documentation code: specified for each individual accessory →  136.

Registered trademarks**HART®**

Registered trademark of the FieldComm Group, Austin, Texas USA

PROFIBUS®

Registered trademark of the PROFIBUS Nutzerorganisation e.V. (PROFIBUS User Organization), Karlsruhe, Germany

FOUNDATION™ Fieldbus

Registration-pending trademark of the FieldComm Group, Austin, Texas, USA

Modbus®

Registered trademark of SCHNEIDER AUTOMATION, INC.

EtherNet/IP™

Trademark of ODVA, Inc.

Ethernet-APL™

Registered trademark of the PROFIBUS Nutzerorganisation e.V. (PROFIBUS User Organization), Karlsruhe, Germany

PROFINET®

Registered trademark of the PROFIBUS Nutzerorganisation e.V. (PROFIBUS User Organization), Karlsruhe, Germany

TRI-CLAMP®

Registered trademark of Ladish & Co., Inc., Kenosha, USA



www.addresses.endress.com
