

Operating Instructions

TDL measurement cell

(0.1, 0.8, 8 and 28 m)

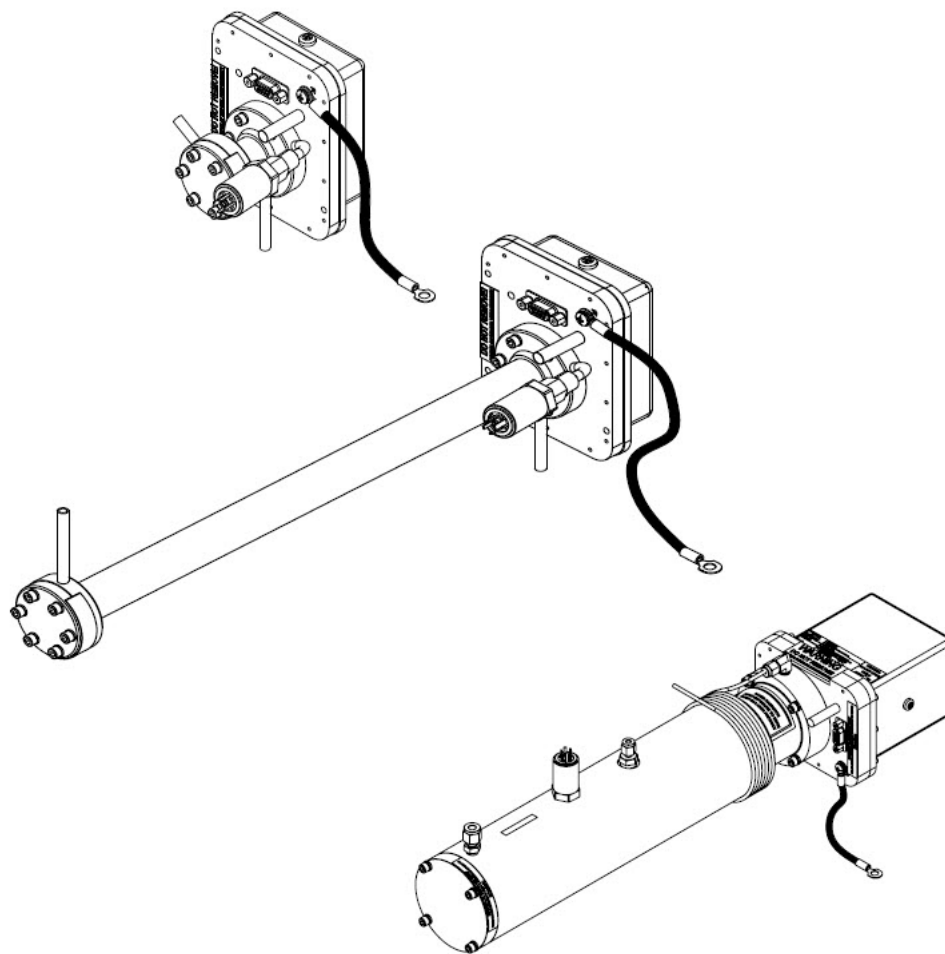



Table of Contents





1 About this document	3	3.3 Mounting the measurement cell	12
1.1 Warnings.....	3	3.4 Connecting the Optical Head to the Junction Box	16
1.2 Symbols on the device.....	3	3.5 Connecting the Gas Lines.....	16
1.3 U.S. export compliance	3	4 Appendix A: specifications.....	18
1.4 List of abbreviations.....	4	4.1 Spare Parts.....	20
2 Introduction.....	6	5 Appendix B: troubleshooting.....	22
2.1 Who should read this manual.....	6	5.1 Cleaning the mirrors.....	22
2.2 How to use this manual	6	5.2 Determining the type of cell mirror	22
2.3 Warning labels	6	5.3 Electrical noise	26
2.4 About the gas analyzer	7	5.4 Instrument problems	26
2.5 How the analyzer works	7	5.5 Disclaimers	27
3 Installation	12	5.6 Warranty.....	28
3.1 What is included in the shipping box.....	12	6 Index	29
3.2 Inspecting the analyzer	12		

1 About this document

1.1 Warnings

Structure of Information	Meaning
<p> WARNING</p> <p>Causes (/consequences) Consequences of noncompliance (if applicable) ▶ Corrective action</p>	<p>This symbol alerts you to a dangerous situation. Failure to avoid the dangerous situation can result in a fatal or serious injury.</p>
<p> CAUTION</p> <p>Causes (/consequences) Consequences of noncompliance (if applicable) ▶ Corrective action</p>	<p>This symbol alerts you to a dangerous situation. Failure to avoid this situation can result in minor or more serious injuries.</p>
<p>NOTICE</p> <p>Cause/situation Consequences of noncompliance (if applicable) ▶ Action/note</p>	<p>This symbol alerts you to situations which may result in damage to property.</p>

1.2 Symbols on the device

Symbol	Description
	The Laser Radiation symbol is used to alert the user to the danger of exposure to hazardous visible laser radiation when using the system.
	The High Voltage symbol that alerts people to the presence of electric potential large enough to cause injury or damage. In certain industries, high voltage refers to voltage above a certain threshold. Equipment and conductors that carry high voltage warrant special safety requirements and procedures.
	The ETL Listed Mark provides proof of product compliance with North American safety standards. Authorities Having Jurisdiction (AHJ) and code officials across the US and Canada accept the ETL Listed Mark as proof of product compliance to published industry standards.
	The WEEE symbol indicates that the product should not be discarded as unsorted waste but must be sent to separate collection facilities for recovery and recycling.
	The CE Marking indicates conformity with health, safety, and environmental protection standards for products sold within the European Economic Area (EEA).

1.3 U.S. export compliance

The policy of Endress+Hauser is in strict compliance with U.S. export control laws as detailed on the website of the [Bureau of Industry and Security](#) at the U.S. Department of Commerce.

1.4 List of abbreviations

Term	Description
AC	alternating current
ALT	alternate
ANSI	American National Standards Institute
ATX	advanced technology extended
ATEX	atmosphere explosible
AWG	American wire gauge
°C	Celsius
CAL	calibration
CDRH	Center for Devices and Radiological Health
CFR	Code of Federal Regulations
cm	centimeter
COLL	collection
CSM	calibration switching module
CSV	comma separated value
DC	direct current
EMC	electromagnetic compatibility
EO	electro-optical
EPL	equipment protection level
EU	European Union
EXC	excitation
FAT	factory acceptance test
FC	fiber channel
G	gas
GLP	good laboratory practice
GMP	good manufacturing practice
HCA	Raman calibration accessory
HPLC	high performance liquid chromatography
Hz	hertz
I/O	input/output
IEC	International Electrotechnical Commission
INTLK	interlock
IP	internet protocol
IPA	isopropyl alcohol
IS	intrinsically safe
LED	light emitting diode
LVS	low voltage safety
mm	millimeter

Term	Description
MPE	maximum permissible exposure
MT	mechanical transfer
mW	milliwatt
NA	numerical aperture
NAT	network address translation
nm	nanometer
NOHD	nominal ocular hazard distance
OPC	Open Platform Communications
OPC UA	OPC Unified Architecture
QbD	quality by design
PAT	process analytical technology
PCM	power control module
PDF	portable document format
PLC	programmable logic controllers
RTU	remote terminal unit
SAT	site acceptance test
SOP	standard operating procedure
SPC	spectrum
TCP	transmission control protocol
UDP	user datagram protocol
UPS	uninterruptible power supply
USB	universal serial bus
USP	SIMCA project file
V	volt
W	watt
WEEE	waste electrical and electronic equipment

2 Introduction

Endress+Hauser systems are high-speed, diode laser-based extractive analyzers designed for extremely reliable monitoring of very low (trace) to standard concentrations of specific components in various background gases. This manual addresses the specifics of the measurement cells used in each analyzer rather than the analyzer as a whole. To ensure that the analyzer performs as specified, it is important to pay close attention to the details of the installation and operation.

2.1 Who should read this manual

This manual should be read and referenced by anyone installing, operating, or having contact with the analyzer.

2.2 How to use this manual

Take a moment to familiarize yourself with the content included in this Operator's Manual by reading the Table of Contents. Read each section in the manual carefully so you can quickly and easily install and operate the measurement cell.

Images, tables, and charts are included to provide a comprehensive understanding of the measurement cell and its functions. Carefully read the section on special symbols which provide key information on the system's configuration and/or operation.

2.3 Warning labels

Instructional icons are provided in all equipment manuals and on the measurement cell to alert the user of potential hazards, important information and valuable tips. Following are the symbols and associated warning and caution types to observe when installing or servicing the cell. Some of these symbols are provided for instructional purposes only and are not labeled on the components.

2.3.1 Equipment labels

This manual uses the following symbols to represent potential hazards, caution alerts, and important information associated with the measurement cells. Every symbol has significant meaning that must be heeded.



This icon denotes a warning statement. Warning statements indicate a potentially hazardous situation, which, if not avoided, may result in serious injury or death.



Failure to follow all directions may result in damage or malfunction of the analyzer.



CLASS 3B LASER PRODUCT- Invisible laser radiation. Avoid direct exposure to beam.



CLASS 1 LASER PRODUCT - Invisible laser radiation when open. Avoid direct exposure to the beam.

2.3.2 Instructional symbols



Important information concerning the installation and operation of the analyzer.

This icon denotes a warning statement. Warning statements indicate a potentially hazardous situation, which, if not avoided, may result in serious injury or death.



Failure to follow all directions may result in damage or malfunction of the analyzer.



Invisible laser radiation when open. Failure to follow all directions could result in personnel injury.



Failure to follow directions may result in fire.

2.4 About the gas analyzer

Endress+Hauser analyzers are tunable diode laser (TDL) absorption spectrometers operating in the near-to short-wavelength infrared. Each compact sensor consists of a TDL light source, sample cell and detector specifically configured to enable high sensitivity measurement of a particular component within the presences of other gas phase constituents in the stream. The sensor is controlled by microprocessor-based electronics with embedded software that incorporates advanced operational and data processing algorithms.

2.5 How the analyzer works

Endress+Hauser analyzers employ tunable diode laser absorption spectroscopy (TDLAS) to detect the presence of trace substances in process gases. Absorption spectroscopy is a widely used technique for sensitive trace species detection. Because the measurement is made in the volume of the gas, the response

is much faster, more accurate and significantly more reliable than traditional surface-based sensors that are subject to surface contamination.

In its simplest form, a diode laser absorption spectrometer typically consists of a sample cell with a mirror at one end and a mirror or window at the other end through which the laser beam can pass, as shown in the figure. The laser beam enters the cell and reflects off the mirror(s) making one or more trips through the sample gas and eventually exiting the cell where the remaining beam intensity is measured by a detector. With the SS2100 analyzer, sample gas flows continuously through the sample cell ensuring that the sample is always representative of the flow in the main pipe.

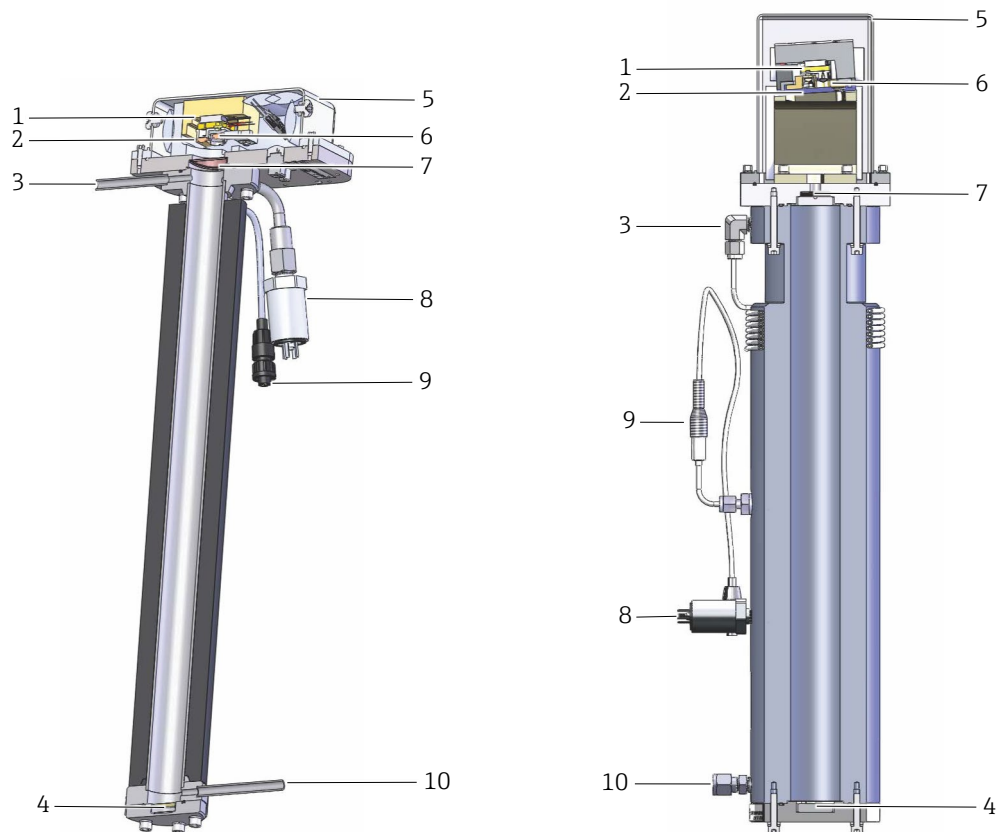

Figure 1: Schematic of a typical laser diode absorption spectrometer: 0.8 m (left) and 8/28 (right)

#	Description
1	TEC
2	Laser
3	Inlet
4	Far mirror
5	Optical head
6	Detector
7	Window
8	Pressure sensor
9	Temperature sensor
10	Outlet

Due to their inherent structure, the molecules in the sample gas each have characteristic natural frequencies (or resonances). When the output of the laser is tuned to one of those natural frequencies, the molecules with that particular resonance can absorb energy from the incident beam. That is, as the beam of incident intensity, $I_0(\lambda)$, passes through the sample, attenuation occurs via absorption by the trace gas with absorption cross section $\sigma(\lambda)$. According to the Beer-Lambert absorption law, the intensity remaining, $I(\lambda)$, as measured by the detector at the end of the beam path of length l (cell length \times number of passes), is given by

$$(1) \quad I(\lambda) = I_0(\lambda) \exp[-\sigma(\lambda)lN],$$

where N represents the species concentration. Thus, the ratio of the absorption measured when the laser is tuned on-resonance versus off-resonance is directly proportional to the number of molecules of that particular species in the beam path, or

$$(2) \quad N = \frac{-1}{\sigma(\lambda)l} \ln \left[\frac{I(\lambda)}{I_0(\lambda)} \right].$$

The figure shows typical raw data (in arbitrary units [a.u.]) from a laser absorption spectrometer scan including the incident laser intensity, $I_0(\lambda)$, and the transmitted intensity, $I(\lambda)$, for a clean system and one with contaminated mirrors (shown to illustrate the systems relative insensitivity to mirror contamination).

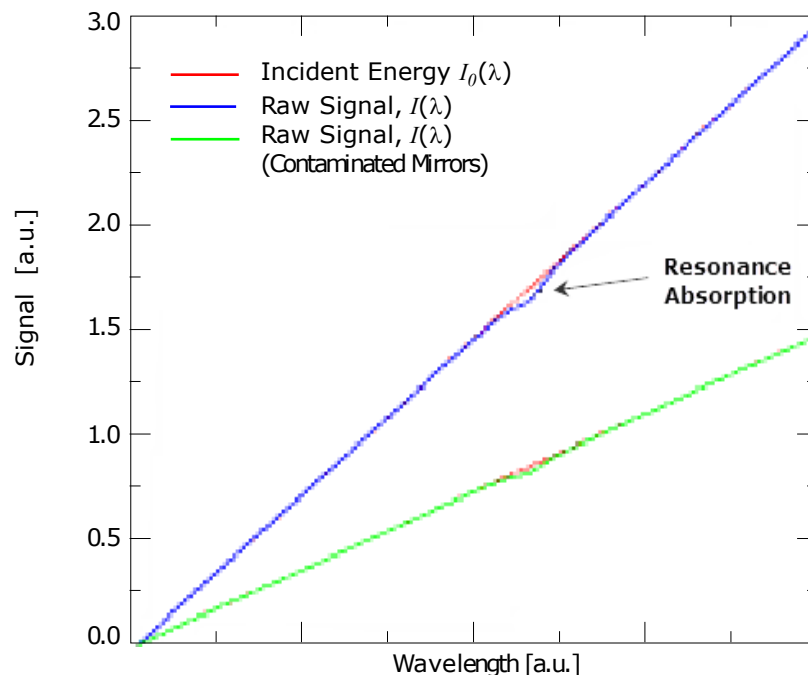

Figure 2: Typical raw signal from a laser diode absorption spectrometer with and without mirror contamination

The positive slope of the raw data results from ramping the current to tune the laser, which not only increases the wavelength with current, but also causes the corresponding output power to increase. By normalizing the signal by the incident intensity, any laser output fluctuations are canceled, and a typical, yet more pronounced, absorption profile results, as shown in the figure.

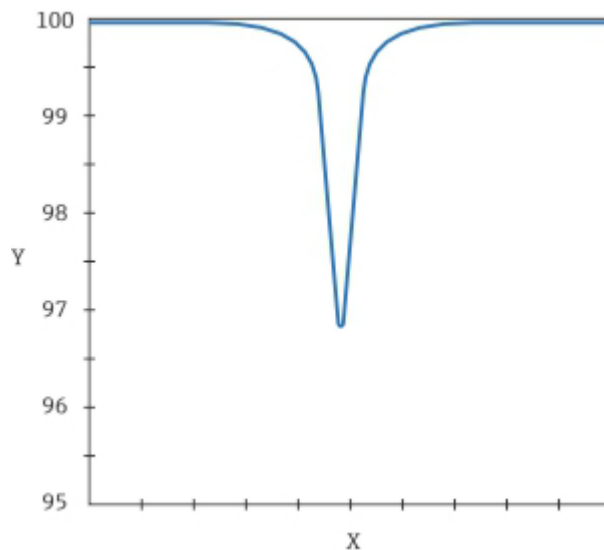

Figure 3: Typical normalized absorption signal from a laser diode absorption spectrometer

Note that contamination of the mirrors results solely in lower overall signal. However, by tuning the laser off-resonance as well as on-resonance and normalizing the data, the technique self-calibrates every scan resulting in measurements that are unaffected by mirror contamination.

Endress+Hauser takes the fundamental absorption spectroscopy concept a step further by using a sophisticated signal detection technique called wavelength modulation spectroscopy (WMS). When employing WMS, the laser drive current is modulated with a kHz sine wave as the laser is rapidly tuned. A lock-in amplifier is then used to detect the harmonic component of the signal that is at twice the modulation frequency ($2f$). Refer to the figure.

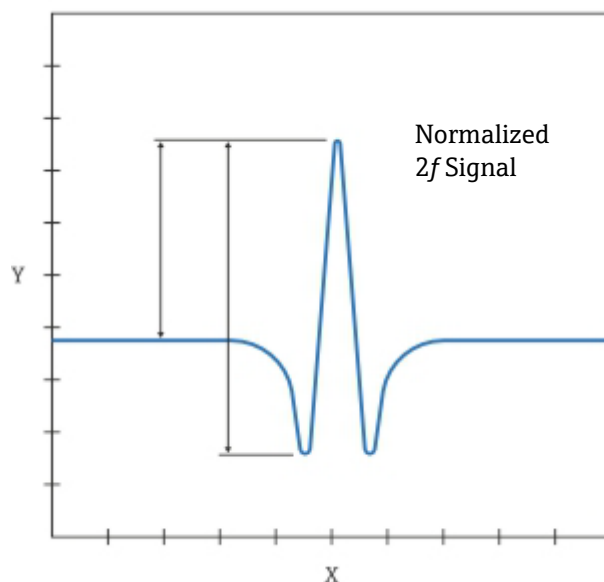

Figure 4: Typical normalized $2f$ signal; species concentration is proportional to the peak height

This phase-sensitive detection enables the filtering of low-frequency noise caused by turbulence in the sample gas, temperature and/or pressure fluctuations, low-frequency noise in the laser beam or thermal noise in the detector.

With the resulting low-noise signal and use of fast post-processing algorithms combined with careful calibration to correct for secondary effects caused by temperature and pressure variations and occasional spectral overlap with background species, reliable parts per million (ppm) or even parts per billion (ppb) detection levels are possible (depending on target and background species) at real-time response rates (on the order of 1 second).

All Endress+Hauser TDL gas analyzers employ the same design and hardware platform. Measuring different trace gases such as H₂O, H₂S, and CO₂, in various mixed hydrocarbon background streams, including natural gas (alkanes), ethylene, propylene, refinery fuel gas, hydrogen reformer gas, syngas and others, is accomplished by simply choosing a different optimum diode laser wavelength between 700 nm and 3000 nm which provides the least amount of sensitivity to background stream variations. Use of ultra-high reliability optical telecommunications diode lasers (manufactured to stringent Telcordia GR 468 specifications), 316L stainless steel, coated optical reflectors, absence of any moving parts, tolerance to condensation of process liquids and accumulation of particulates from gas streams eliminates requirements for field calibration and frequent maintenance making Endress+Hauser TDL analyzers the most reliable gas analyzer platform with the lowest total cost of ownership.

3 Installation

This section describes the processes used to initially install and configure the measurement cell. Once the analyzer arrives, take a few minutes to examine the contents before installing the unit.

3.1 What is included in the shipping box

The contents of the box include:

- Measurement cell
- Measurement cell mounting kit
- Temperature/pressure sensor cable (application-dependent)
- Optical head cable (application dependent)
- A USB with this manual

If any of these contents are missing, contact *Service* → .

3.2 Inspecting the analyzer

Unpack and place the measurement cell on a flat surface. Carefully inspect all pieces for dents, dings, or general damage. Inspect the supply and return connections for damage, such as bent tubing. Report any damage to the carrier.



Avoid jolting the cell by dropping it or banging it against a hard surface. This action could disturb the optical alignment.

3.3 Mounting the measurement cell

The measurement cell is designed for mounting on a panel inside a protective enclosure with a rating of IP54 or better. A mounting kit is included with the measurement cell.



It is critical to mount the analyzer so that the supply and return lines reach the supply and return connections on the chassis while still maintaining flexibility so that the sample lines are not under excessive stress.

3.3.1 To mount a 8 m or 28 m measurement cell

Select a location to mount the measurement cell with an environment that conforms to the specified operating conditions. The measurement cell may be mounted vertically (with the optical head on top) or horizontally.

1. Mark the mounting holes on the panel. Refer to the figure. Drill four clearance holes, if using machine screws, or drill and tap four 1/4-20 holes, if using studs.

1. Mark the mounting holes on the panel. Refer to the figure. Drill and tap the 1/4-20 holes.



The 0.1 m cell uses the two mounting holes at the top only. The 0.8 m cell uses both mounting holes at the top and bottom.

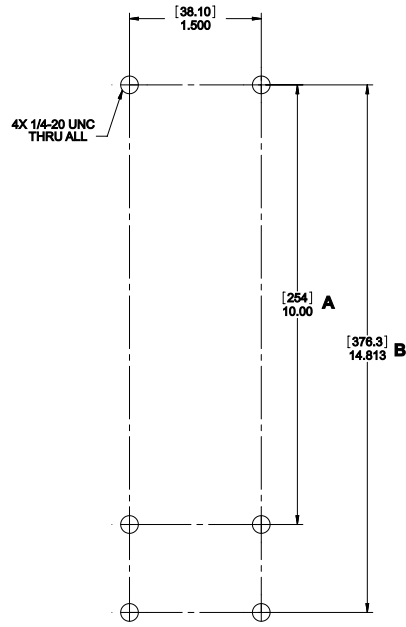

Figure 7: Hole pattern for mounting 0.1 m and 0.8 m measurement cell

#	Description
A	Vertical mounting dimension for SS2100i-1
B	Vertical mounting dimension for SS2100i-2

2. Mount cell with bracket. Refer to the figures.

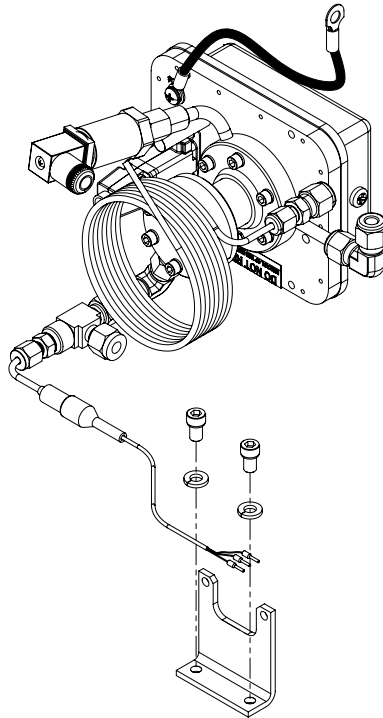

Figure 8: Mounting bracket assembly drawing for 0.1 m measurement cell

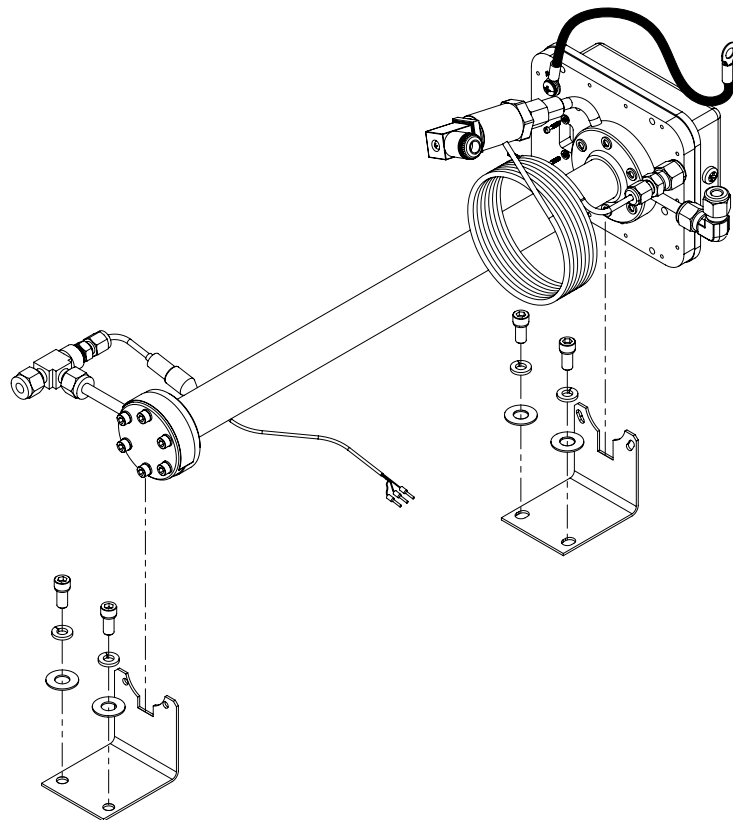



Figure 9: Mounting bracket assembly drawing for 0.8 m measurement cell

3.4 Connecting the Optical Head to the Junction Box

For systems with remotely mounted electronics, the cables connecting the optical head to the electronics must be installed. Sample cell cable assemblies of the appropriate type and length, as shown in the figure, should have been provided with the cell. If a different length than what was provided is required, please contact *Service* → . All work must be performed by qualified personnel in compliance with local regulations.



This equipment must be protected against transients or surges. Transient or surge protection is located in the accompanying electronics.



For detailed wiring diagrams, please refer to the electrical schematics provided in the system Operating Instruction.

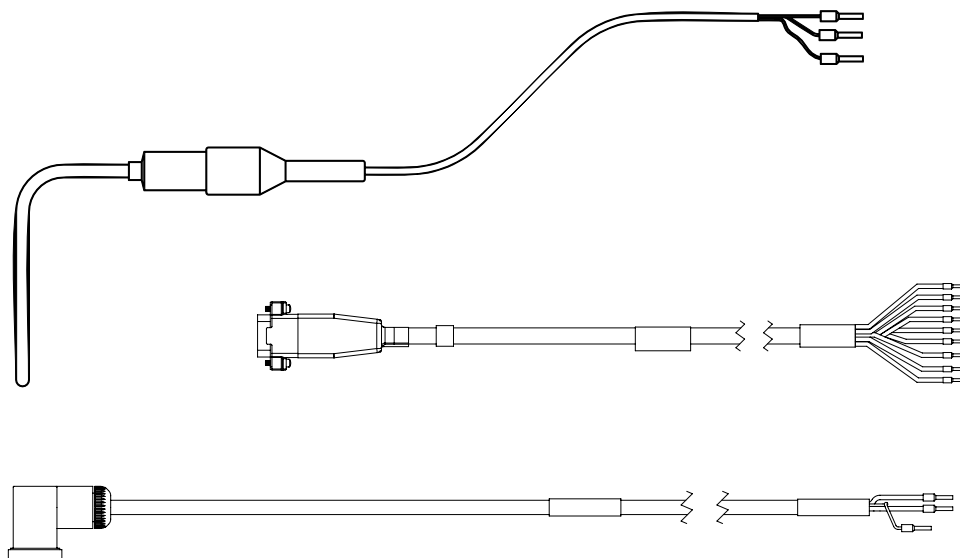

Figure 10: Sample cell cable assemblies

3.5 Connecting the Gas Lines



A 7- μ m particle filter must be installed in series upstream of the measurement cell.

Once you have verified that the analyzer is functional and that the analyzer circuit is de-energized, you are ready to connect the sample supply and return gas lines. All work needs to be performed by technicians qualified in pneumatic tubing.

Endress+Hauser recommends using 1/4 in. O.D x 0.035 in. wall thickness, seamless stainless steel tubing. Refer to the measurement cell outline drawings in Appendix A for supply and return port locations.

3.5.1 To connect the sample supply line

1. Determine appropriate tubing route from the sample system to the measurement cell.
2. Run stainless steel tubing from the sample system supply port (set for the specified supply pressure) to the sample supply port of the measurement cell. Bend tubing using industrial grade benders, check tubing fit to ensure proper seating between the tubing and fittings. Fully ream all tubing ends. Blow out the lines for 10 to 15 seconds with clean, dry nitrogen or air prior to making the connection.
3. Connect the sample supply tube to the measurement cell using the 1/4 in. stainless steel compression-type fitting provided.
4. Tighten all new fittings 1-1/4 turns with a wrench from finger tight. For connections with previously swaged ferrules, thread the nut to the previously pulled up position, then tighten slightly with a wrench. Secure tubing to appropriate structural supports as required.
5. Check all connections for gas leaks. Endress+Hauser recommends using a liquid leak detector.



Do not exceed 0.7 barg (10 PSIG) in sample cell. Damage to cell may result.

3.5.2 To connect the sample return

1. Determine appropriate tubing route from the measurement cell to the sample system return.
2. Run stainless steel tubing from the sample return port of the measurement cell to the sample system return port. Bend tubing using industrial grade benders, check tubing fit to ensure proper seating between the tubing and fittings. Fully ream all tubing ends. Blow out the lines for 10 to 15 seconds with clean, dry nitrogen or air prior to making the connection.
3. Connect the sample return tube to the measurement cell using the 1/4 in. stainless steel compression-type fitting provided.
4. Tighten all new fittings 1-1/4 turns with a wrench from finger tight. For connections with previously swaged ferrules, thread the nut to the previously pulled up position, then tighten slightly with a wrench. Secure tubing to appropriate structural supports as required.
5. Check all connections for gas leaks. A liquid leak detector is recommended.



Do not exceed 0.7 barg (10 PSIG) in sample cell. Damage to cell may result.

4 Appendix A: specifications

Performance	
Wavelength	760 to 3000 nm
Laser output power	2 to 20 mW
Scan rate	3.8 Hz
Application Data	
Environmental temperature range	-20 °C to 50 °C (-4 °F to 122 °F) -10 °C to 60 °C (-14 °F to 140 °F) - <i>Optional</i>
Environmental relative humidity	5% to 95%, Non-condensing
Altitude	Up to 2000 m (6,550 ft.)
Cell operating pressure	-0.3 to 0.7 barg (-4.5 to 10 PSIG)
Filtration	7- μ m particle filtration
Measurement cell flow rate	3 LPM (6.3 CFH) [28 m and 8 m] 1 LPM (2.1 CFH) [0.8 m]
Contaminant sensitivity	None for gas phase glycol, methanol, amines, or mercaptans.
Electrical	
Laser input	250 mA max, 3 VDC max
TE cooler input	1.6 A max, 3 VDC max
Photodiode bias	2.5 VDC
Physical specifications	
Size	149 mm H \times 103 mm W \times 107 mm D [0.1 m] (5.86 in. H \times 4.05 in. W \times 4.21 in. D) 439 mm H \times 125 mm W \times 118 mm D [0.8 m] (17.3 in. H \times 4.9 in. W \times 4.6 in. D) 515 mm H \times 153 mm W \times 182 mm D [8 m] (20.3 in. H \times 6.0 in. W \times 7.1 in. D)

	556 mm H × 153 mm W × 182 mm D [28 m] (21.9 in. H × 6.0 in. W × 7.1 in. D)
Weight	0.91 kg (Approx. 2 lbs) [0.1 m] 2.3 kg (Approx. 5.0 lbs) [0.8 m] 10.3 kg (Approx. 22.7 lbs) [8 m] 11.1 kg (Approx. 24.5 lbs) [28 m]
Construction	316L series polished stainless steel
Area classification	
Standards	IEC 60079-0 : 2017 Ed.7 EN IEC 60079-0 : 2018 IEC/EN 60079-15 : 2010 Ed.4 IEC/EN 60079-28 : 2015 Ed.2
Certification	Ex II 3G Ex nA, op is IIC Gc LCIE 10 ATEX 1002U IECEX EPS 12.0011U

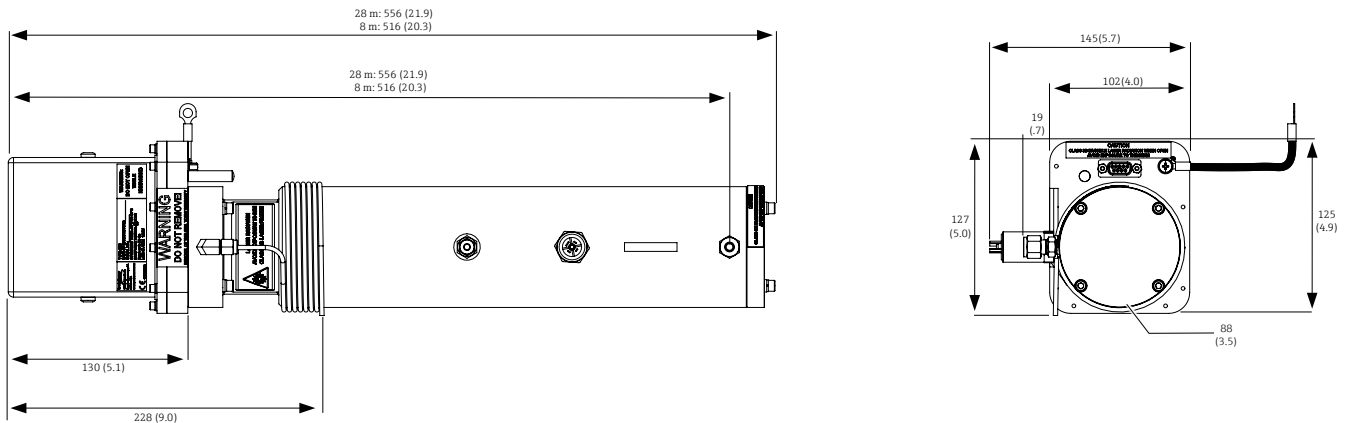

Figure 11: Outline schematic of 8 m and 28 m measurement cells. Dimensions: mm (in)

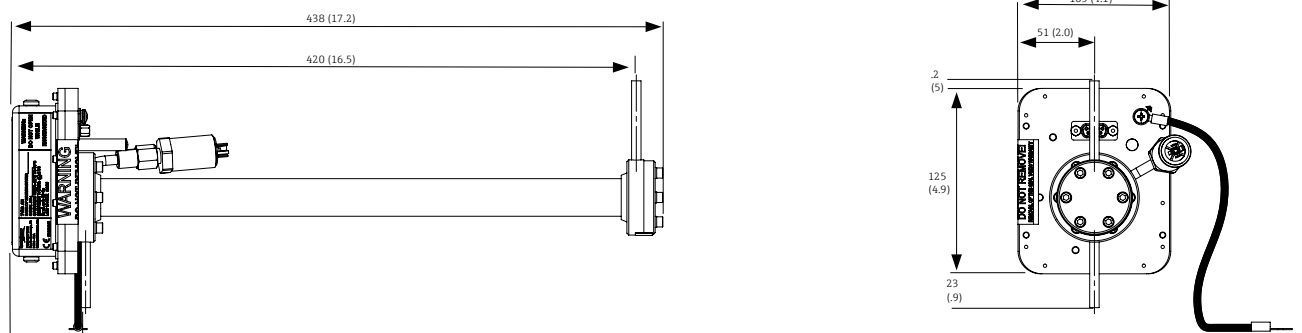

Figure 12: Outline schematic of 0.8 measurement cells. Dimensions: mm (in)

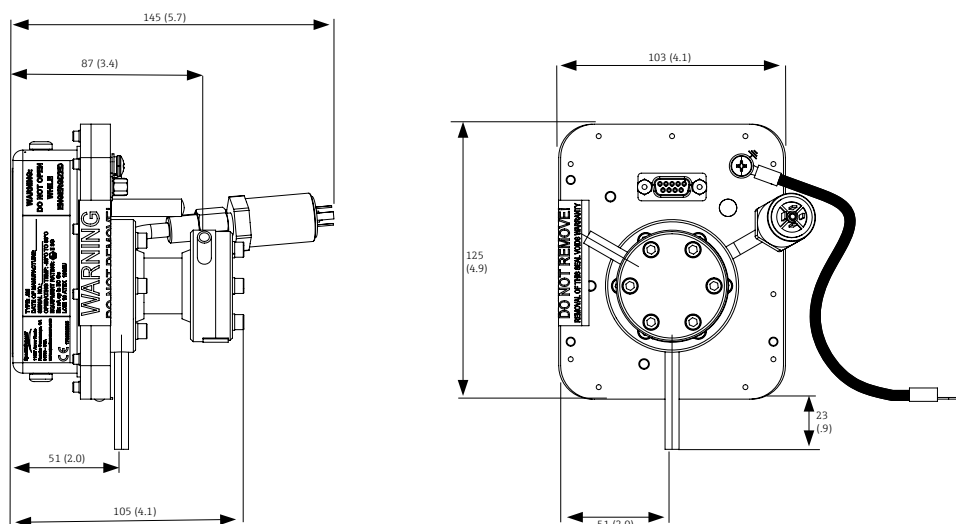

Figure 13: Outline schematic of 0.1 m measurement cells. Dimensions: mm (in)

4.1 Spare Parts

Below is a list of spare parts for the TDL Sample Cell analyzer with recommended quantities for 2 years of operation.

Due to a policy of continuous improvement, parts and part numbers may change without notice. Not all parts listed are included on every analyzer. When ordering, please specify the system serial number (SN) to ensure that the correct parts are identified.

Part Number	Description	2 YR QTY
Cell (0.1 m)		
70162334	Pressure Sensor	1
70156899	Thermistor	-
70156810	Stainless Steel Mirror	1
Cell (0.8 m)		
70162334	Pressure Sensor	1
70162334	Thermistor	-
70156809	Kit, Spares (O-rings, Screws), Viton, 0.8 m Cell	1
70156817	Kit, Cleaning Tools, Optical Cell (USA/Canada only) ¹	-
70156818	Kit, Cleaning Tools, Optical Cell (International) ¹	-

Cell [8 m and 28 m]		
70162334	Pressure Sensor	1
70156899	Thermistor	-
70156703	Kit, Spares (O-rings, Screws), Viton, 2-Pass Cell	1
70156817	Kit, Cleaning Tools, Optical Cell (USA/Canada only) ¹	-
70156818	Kit, Cleaning Tools, Optical Cell (International) ¹	-



For a complete listing of new or updated certificates, please visit the product page at www.endress.com.

¹1. Refer to Endress+Hauser *Service* →  before attempting use. Servicing this component without technical support could cause damage to other components.

5 Appendix B: troubleshooting

This section presents recommendations and solutions to common problems. If the sample cell demonstrates issues not mentioned here, refer to *Service* →  for additional assistance.

5.1 Cleaning the mirrors

If contamination makes its way into the cell and accumulates on the internal optics, a **Laser Power too Low** fault can result. If mirror contamination is suspected, please refer to *Service* →  for additional assistance before attempting to clean the mirror. If advised to do so, use the following procedure.

Do not attempt to clean the cell mirror until you have consulted with a technical service representative and have been advised to do so.



The sample cell assembly contains a low-power, 20 mW MAX, CW Class 3b invisible laser with a wavelength between 700-3000 nm. Never remove the end mirror unless the power is turned off.

5.1.1 Tools and supplies

- Lens cleaning cloth (Cole Parmer® EW-33677-00 TEXWIPE® Alphawipe® Low-Particulate Clean Room Wipes or equivalent)
- Reagent-grade Isopropyl alcohol (ColeParmer® EW-88361-80 or equivalent)
- Small drop dispenser bottle (Nalgene® 2414 FEP Drop Dispenser Bottle or equivalent)
- Acetone-impenetrable gloves (North NOR CE412W Nitrile Chemsoft™ CE Clean-room Gloves or equivalent)
- Hemostat (Fisherbrand™ 13-812-24 Rochester-Pean Serrated Forceps)
- Bulb blower or dry compressed air/nitrogen
- Torque wrench
- Marker
- Flashlight

5.2 Determining the type of cell mirror

Measurement cells come equipped with either a glass or stainless steel mirror. Before determining whether to clean or replace the mirror, identify the type of measurement cell (0.1 m, 0.8 m, 8/28 m) being used in the analyzer.

The stainless steel mirrors are identified with either an “X” engraved on the outside bottom of the mirror or a groove around the rim of the mirror. Glass mirrors have no external markings. To determine the type of mirror being used for the system cell:

1. Feel at the bottom of the cell for the engraved ‘X’ marking. Refer to the figure.

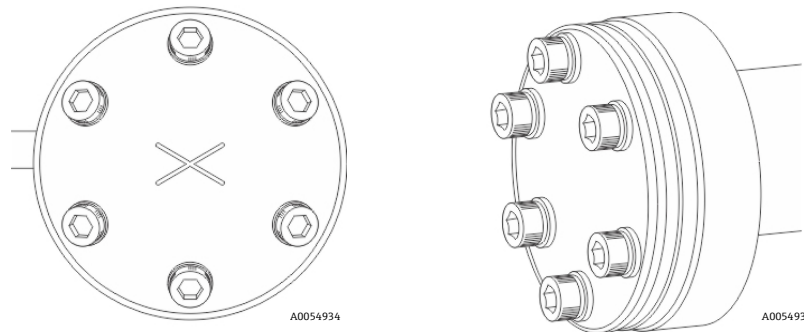

Figure 14: Stainless steel mirror marked with an 'x' (left) and mirror grooved rim (right)

- a. If the surface is smooth, a glass mirror is being used.
- b. If the surface is rough, or an engraving is detected, a stainless steel mirror is being used.



A stainless steel mirror may only be replaced with a stainless steel mirror. A glass mirror cannot be replaced. Do not attempt to replace a glass mirror with a stainless steel mirror of system calibration may be adversely affected.

To clean the mirror, refer to the instructions *To clean the mirror* → . To replace a stainless steel mirror, refer to the instructions for *To replace the stainless steel mirror* → .

5.2.1 To clean the mirror

1. Power down the analyzer following the procedure outlined in the section called Powering Down the Analyzer in the Firmware Operator's Manual.
2. Isolate the analyzer from the sample bypass flow by shutting off the appropriate valve(s) and/or pressure regulator. Follow the procedure outlined in Isolating the Measurement Cell for Short-term Shutdown in the Firmware Operator's Manual.



Operate all valves, regulators, and switches in accordance with site lock-out/tag-out procedures.

3. If possible, purge the measurement cell with nitrogen for 10 minutes.



Process samples may contain hazardous material in potentially flammable and/or toxic concentrations. Personnel must have a thorough knowledge and understanding of the physical properties and safety precautions for the sample contents before operating the SCS.

4. Carefully mark the orientation of the mirror assembly on the cell body.

Careful marking of the mirror orientation is critical to restoring system performance upon reassembly after cleaning.

5. Gently remove the mirror assembly from the cell by removing the socket-head cap screws and set on a clean, stable and flat surface.



The sample cell assembly contains a low-power, 20 mW MAX, CW Class 3b invisible laser with a wavelength between 750-3000 nm. Never open the sample cell flanges or the optical assembly unless the power is turned off.



Always handle the optical assembly by the edge of the mount. Never touch the coated surfaces of the mirror.

6. Look inside the sample cell at the top mirror using a flashlight to ensure that there is no contamination on the top mirror.



Endress+Hauser does not recommend cleaning the top mirror. If the top mirror is visibly contaminated, refer to *Service* → .

7. Remove dust and other large particles of debris using a bulb blower or dry compressed air/nitrogen. Pressurized gas duster products are not recommended as the propellant may deposit liquid droplets onto the optic surface.
8. Put on clean acetone-impenetrable gloves.
9. Double fold a clean sheet of lens cleaning cloth and clamp near and along the fold with the hemostats or fingers to form a “brush.”
10. Place a few drops of Isopropyl alcohol onto the mirror and rotate the mirror to spread the liquid evenly across the mirror surface.
11. With gentle, uniform pressure, wipe the mirror from one edge to the other with the cleaning cloth only once and only in one direction to remove the contamination. Discard the cloth.



Never rub an optical surface, especially with dry tissues, as this can mar or scratch the coated surface.

12. Repeat with a clean sheet of lens cleaning cloth to remove the streak left by the first wipe. Repeat, if necessary, until there is no visible contamination on the mirror.
13. Carefully replace the mirror assembly onto the cell in the same orientation as previously marked making sure the O-ring is properly seated.
14. Tighten the socket-head cap screws evenly with a torque wrench to 13 in-lbs.

5.2.2 To replace the stainless steel mirror

If your system has been configured with a stainless steel mirror in the 0.1 m or 0.8 m measurement cell, use the following instructions for replacing the mirror.



Refer to *Service* →  if a glass mirror requires replacement. Do not attempt to replace a glass mirror with a stainless steel mirror or system calibration may be adversely affected.

1. Power down the analyzer following the procedure outlined in the section called Powering down the analyzer in the Firmware operator's manual.
2. Isolate the analyzer from the sample bypass flow by shutting off the appropriate valve(s) and/or pressure regulator.



Operate all valves, regulators, and switches in accordance with site lock-out/tag-out procedures.

3. If possible, purge the measurement cell with nitrogen for 10 minutes.



Process samples may contain hazardous material in potentially flammable and/or toxic concentrations. Personnel must have a thorough knowledge and understanding of the physical properties and safety precautions for the sample contents before operating the SCS.

4. Gently remove the mirror assembly from the cell by removing the socket-head cap screws and set on a clean, stable and flat surface.



The sample cell assembly contains a low-power, 20 mW MAX, CW Class 3b invisible laser with a wavelength between 750 to 3000 nm. Never open the sample cell flanges or the optical assembly unless the power is turned off.



Always handle the optical assembly by the edge of the mount. Never touch the optical surfaces of the mirror.



5. Confirm need to replace mirror due to contamination. If yes, set mirror aside.
6. Put on clean acetone-impenetrable gloves.
7. Obtain the new stainless steel mirror.
8. Check the O-ring.
 - a. If a new O-ring is needed, apply grease on fingertips and then to the new O-ring.
 - b. Place newly greased O-ring into the groove around the outside of the mirror taking care not to touch the mirror surface.
9. Carefully place the new stainless steel mirror onto the cell making sure the O-ring is properly seated.
10. Tighten the socket-head cap screws evenly with a torque wrench to 13 in-lbs.

5.3 Electrical noise

High levels of electrical noise can interfere with laser operation and cause it to become unstable. Always connect the analyzer to a properly grounded power source.

5.4 Instrument problems

Refer to the table for solutions to possible measurement cell issues before contacting Service.

Symptom	Response
Laser Power too Low fault	Turn off the power to the unit and check the optical head cables for a loose connection. Do not disconnect or reconnect any optical head cables with the power connected.
	Check the inlet and outlet tubes to see if they are under any stress. Remove the connections to the inlet and outlet tubes and see if the power goes up. Perhaps the existing tubing needs to be replaced with stainless steel flexible tubing.
	Possible alignment problem. Contact <i>Service</i> →  .
	Possible mirror contamination issue. Contact <i>Service</i> →  . If advised to do so, clean the mirrors by following the instructions under <i>To clean the mirror</i> →  .

Pressure too Low or Pressure too High fault	Check that the actual pressure in the measurement cell is within specification (Table A-1 on page A-1).
	If the pressure reading is incorrect, check that the pressure/temperature cable is tight. Check the connector on the pressure transducer. Check the pressure connector on the backplane board.

Symptom	Response
Temperature too Low or Temperature too High fault	Check that the actual temperature in the measurement cell is within specification (Table A-1 on page A-1). For systems with a heated enclosure, check that the temperature in the measurement cell is within $\pm 5\text{ }^{\circ}\text{C}$ of the specified enclosure temperature.
	If the temperature reading is incorrect, check the pressure/temperature cable tight. Check the connector on the cell temperature sensor. Check the temperature connector on the backplane board. (NOTE: A temperature reading greater than $150\text{ }^{\circ}\text{C}$ indicates a short circuit on the temperature sensor leads; a reading of less than $-40\text{ }^{\circ}\text{C}$ indicates an open circuit).

5.4.1 Renewity returns

Returns can also be made inside the USA through the Renewity system. From a computer, navigate to www.endress.com and complete the online form.

5.5 Disclaimers

Endress+Hauser accepts no responsibility for consequential damages arising from the use of this equipment. Liability is limited to replacement and/or repair of defective components.

This manual contains information protected by copyright. No part of this guide may be photocopied or reproduced in any form without prior written consent from Endress + Hauser.

5.6 Warranty

For a period of 18 months from date of shipment or 12 months in operation, whichever comes first, Endress+Hauser warrants that all products sold by it must be free from defects in material and workmanship under normal use and service when correctly installed and maintained. Endress+Hauser's sole liability and Customer's sole and exclusive remedy for a breach of warranty is limited to Endress+Hauser's repair or replacement (at Endress+Hauser's sole option) of the product or part thereof which is returned at Customer's expense to Endress+Hauser's plant. This warranty must apply only if Customer notifies Endress + Hauser in writing of the defective product promptly after the discovery of the defect and within the warranty period. Products may only be returned by Customer when accompanied by a return authorization reference number (SRO) issued by Endress+Hauser. Freight expenses for products returned by Customer is be prepaid by Customer. Endress+Hauser must pay for shipment back to Customer for products repaired under warranty. For products returned for repair that are not covered under warranty, Endress+Hauser's standard repair charges must be applicable in addition to all shipping expenses.

6 Index

- Absorption, 7, 9
- Absorption coefficient, 9
- Absorption profile, 9
- Acetone-impenetrable gloves, 22, 24, 26
- Attenuation, 9
- Background gas, 6
- Beam path, 9
- Beer-Lambert absorption law, 9
- Cleaning
 - Mirrors, 22
- Connecting the sample return line, 17
- Connecting the sample supply line, 17
- Contamination, 10
- Current tuning, 9
- Data, 9
 - Raw, 9
- De-energizing the circuit, 16
- Detection levels, 11
- Detector, 8, 9
- Diode laser absorption spectrometer, 8
- Electrical noise, 26
- export
 - compliance, 3
- Faults
 - Laser Power too Low, 22, 26
 - Pressure too High, 27
 - Pressure too Low, 27
 - Temperature too High, 27
- Gas leaks, 17
- Gas lines, 16
- glossary, 4
- Incident energy, 9
- Incident intensity, 9
- Isopropyl alcohol, 22, 24
- Laser absorption spectrometer, 9
- Laser beam, 8
- Laser output fluctuations, 9
- Leak detector, 17
- Lens cleaning cloth, 22, 24
- Lock-in amplifier, 10
- Mirror contamination, 9, 10, 22
- Natural frequencies, 9
- Port
 - Sample return, 17
 - Sample supply, 17
- Potential hazards, 6
- Resonances. See Natural Frequencies, 9
- Sample condition system (SCS), 23, 25
- Sample gas, 8, 9
- Species concentration, 9
- Spectral overlap, 11
- Stainless steel tubing, 16, 17
- symbols, 3
- Symbols, 6
- Tools and supplies, 22
- Trace species detection, 7
- Tunable diode laser absorption spectroscopy (TDLAS), 7
- us export compliance, 3
- Variations, 11
 - Pressure, 11
 - Temperature, 11
- Wavelength modulation spectroscopy, 10

www.addresses.endress.com
