

Brief Operating Instructions

Liquiphant FTL43

IO-Link

Vibronic
Point level switch for liquids



These Instructions are Brief Operating Instructions; they are not a substitute for the Operating Instructions pertaining to the device.

Detailed information about the device can be found in the Operating Instructions and the other documentation:

Available for all device versions via:

- Internet: www.endress.com/deviceviewer
- Smart phone/tablet: *Endress+Hauser Operations App*

1 Associated documentation



2 About this document

2.1 Document function

The Brief Operating Instructions contain all the essential information from incoming acceptance to initial commissioning.

2.2 Symbols

2.2.1 Safety symbols

DANGER

This symbol alerts you to a dangerous situation. Failure to avoid this situation will result in serious or fatal injury.

WARNING

This symbol alerts you to a dangerous situation. Failure to avoid this situation can result in serious or fatal injury.

CAUTION

This symbol alerts you to a dangerous situation. Failure to avoid this situation can result in minor or medium injury.

NOTICE

This symbol contains information on procedures and other facts which do not result in personal injury.

2.2.2 Tool symbols

 Open-ended wrench

2.2.3 Communication-specific symbols

Bluetooth®: 

Wireless data transmission between devices over a short distance.

IO-Link:  **IO-Link**

Communications system for connecting intelligent sensors and actuators to an automation system. In the IEC 61131-9 standard, IO-Link is standardized under the description "Single-drop digital communication interface for small sensors and actuators (SDCI)".

2.2.4 Symbols for certain types of Information

Permitted: 

Procedures, processes or actions that are permitted.

Forbidden: 

Procedures, processes or actions that are forbidden.

Additional information: 

Reference to documentation: 

Reference to page: 

Series of steps: [1.](#), [2.](#), [3.](#)

Result of an individual step: 

2.2.5 Symbols in graphics

Item numbers: 1, 2, 3 ...

Series of steps: [1.](#), [2.](#), [3.](#)

Views: A, B, C, ...

2.3 Documentation

 For an overview of the scope of the associated Technical Documentation, refer to the following:

- *Device Viewer* (www.endress.com/deviceviewer): Enter the serial number from the nameplate
- *Endress+Hauser Operations app*: Enter serial number from nameplate or scan matrix code on nameplate.

2.4 Registered trademarks

Apple®

Apple, the Apple logo, iPhone, and iPod touch are trademarks of Apple Inc., registered in the U.S. and other countries. App Store is a service mark of Apple Inc.

Android®

Android, Google Play and the Google Play logo are trademarks of Google Inc.

Bluetooth®

The *Bluetooth*® word mark and logos are registered trademarks owned by the Bluetooth SIG, Inc. and any use of such marks by Endress+Hauser is under license. Other trademarks and trade names are those of their respective owners.

IO-Link®

Is a registered trademark. It may only be used in conjunction with products and services by members of the IO-Link Community or by non-members who hold an appropriate license. For more detailed information on its use, refer to the rules of the IO-Link Community at:

www.io.link.com.

3 Basic safety instructions

3.1 Requirements for the personnel

The personnel must fulfill the following requirements for its tasks:

- ▶ Trained, qualified specialists must have a relevant qualification for this specific function and task.
- ▶ Are authorized by the plant owner/operator.
- ▶ Are familiar with federal/national regulations.
- ▶ Before starting work, read and understand the instructions in the manual and supplementary documentation as well as the certificates (depending on the application).
- ▶ Follow instructions and comply with basic conditions.

3.2 Intended use

The device described in this manual is intended only for the level measurement of liquids.

Incorrect use

The manufacturer is not liable for damage caused by improper or unintended use.

Avoid mechanical damage:

- ▶ Do not touch or clean device surfaces with pointed or hard objects.

Clarification for borderline cases:

- ▶ For special media and fluids for cleaning, Endress+Hauser is glad to provide assistance in verifying the corrosion resistance of fluid-wetted materials, but does not accept any warranty or liability.

Residual risks

Due to the transfer of heat from the process and power dissipation within the electronics, the temperature of the housing may increase to up to 80 °C (176 °F) during operation. When in operation, the sensor can reach a temperature close to the medium temperature.

Danger of burns from contact with surfaces!

- ▶ In the event of elevated fluid temperatures, ensure protection against contact to prevent burns.

3.3 Workplace safety

When working on and with the device:

- ▶ Wear the required personal protective equipment as per national regulations.
- ▶ Switch off the supply voltage before connecting the device.

3.4 Operational safety

Risk of injury!

- ▶ Operate the device only if it is in proper technical condition, free from errors and faults.
- ▶ The operator is responsible for trouble-free operation of the device.

Modifications to the device

Unauthorized modifications to the device are not permitted and can lead to unforeseeable dangers:

- ▶ If modifications are nevertheless required, consult with the manufacturer.

Repair

To ensure continued operational safety and reliability:

- ▶ Only use original accessories.

Hazardous area

To eliminate the risk of danger to persons or the facility when the device is used in the hazardous area (e.g. explosion protection, pressure equipment safety):

- ▶ Check the nameplate to verify if the device ordered can be put to its intended use in the hazardous area.
- ▶ Comply with the instructions in the separate supplementary documentation, which is an integral part of this manual.

3.5 Product security

This state-of-the-art device is designed and tested in accordance with good engineering practice to meet operational safety standards. It left the factory in a condition in which it is safe to operate.

The device fulfills general safety requirements and legal requirements. It also complies with the EU directives listed in the device-specific EU Declaration of Conformity. Endress+Hauser confirms this fact by affixing the CE mark.

3.6 IT security

Our warranty is valid only if the product is installed and used as described in the Operating Instructions. The product is equipped with security mechanisms to protect it against any inadvertent changes to the settings.

IT security measures, which provide additional protection for the product and associated data transfer, must be implemented by the operators themselves in line with their security standards.

3.7 Device-specific IT security

The device offers specific functions to support protective measures by the operator. These functions can be configured by the user and guarantee greater in-operation safety if used correctly. The user role can be changed with an access code (applies to operation via Bluetooth or FieldCare, DeviceCare or asset management tools (e.g. AMS, PDM).

3.7.1 Access via Bluetooth® wireless technology

Secure signal transmission via Bluetooth® wireless technology uses an encryption method tested by the Fraunhofer Institute.

- Without the SmartBlue app, the device is not visible via Bluetooth® wireless technology.
- Only one point-to-point connection is established between the device and a smartphone or tablet.
- The Bluetooth® wireless technology interface can be disabled via onsite operation or via SmartBlue.

4 Incoming acceptance and product identification

4.1 Incoming acceptance

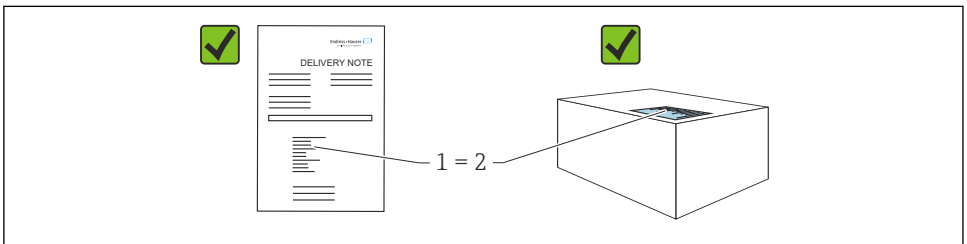

A0016870

Check the following during incoming acceptance:

- Is the order code on the delivery note (1) identical to the order code on the product sticker (2)?
- Are the goods undamaged?
- Do the data on the nameplate correspond to the order specifications and the delivery note?
- Is the documentation provided?
- If required (see nameplate), are the Safety Instructions (XA) provided?



If one of these conditions is not met, please contact the manufacturer's sales office.

4.2 Product identification

The following options are available for identification of the device:

- Nameplate specifications
- Order code with breakdown of the device features on the delivery note
- Enter the serial numbers from the nameplates in *Device Viewer* (www.endress.com/deviceviewer): all the information about the device is displayed.

4.2.1 Nameplate

The information that is required by law and is relevant to the device is shown on the nameplate, e.g.:

- Manufacturer identification
- Order number, extended order code, serial number
- Technical data, degree of protection

- Firmware version, hardware version
- Approval-specific information
- DataMatrix code (information about the device)

Compare the data on the nameplate with your order.

4.2.2 Manufacturer address

Endress+Hauser SE+Co. KG
Hauptstraße 1
79689 Maulburg, Germany

Place of manufacture: See nameplate.

4.3 Storage and transport

4.3.1 Storage conditions

- Use the original packaging
- Store the device in clean and dry conditions and protect from damage caused by shocks

Storage temperature

-40 to +85 °C (-40 to +185 °F)

4.3.2 Transporting the product to the measuring point

⚠ WARNING

Incorrect transport!

Housing and tuning fork may become damaged, and there is a risk of injury.

- ▶ Transport the device to the measuring point in the original packaging.
- ▶ Hold the device by the housing, temperature spacer, process connection or extension pipe.
- ▶ Do not bend, shorten or extend the tuning fork.

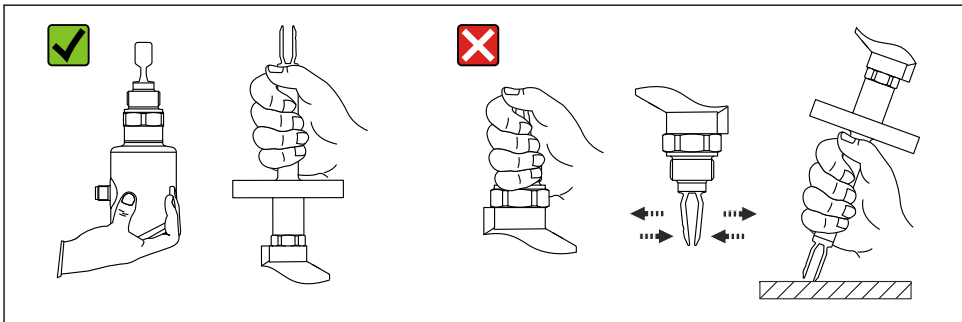

A0053361

1 Handling the device

5 Mounting

- Any orientation for compact version or version with a tube length up to approx. 500 mm (19.7 in)
- Vertical orientation from above for device with long pipe
- Minimum distance between the tuning fork and the tank wall or pipe wall: 10 mm (0.39 in)

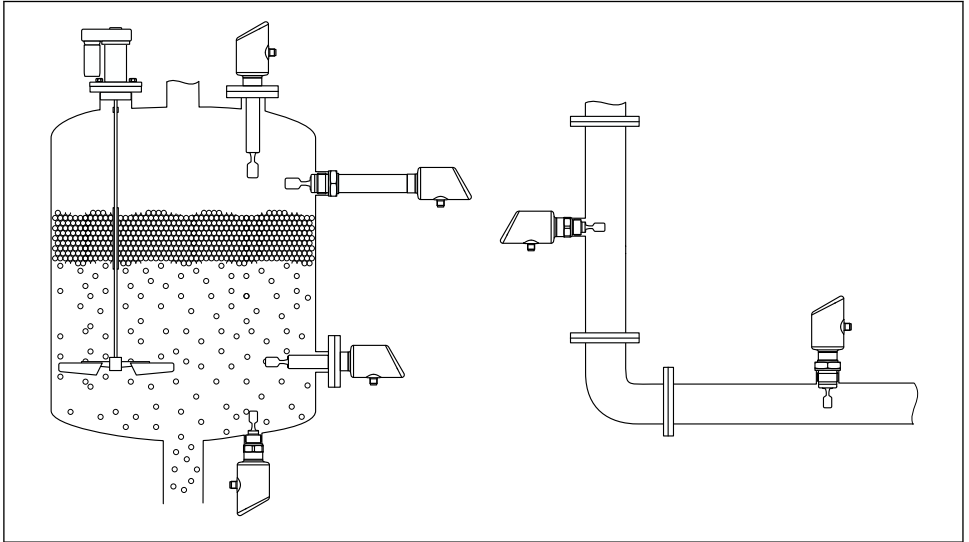

A0053113

2 Installation examples for a vessel, tank or pipe

5.1 Mounting requirements

5.1.1 Mounting instructions

i During installation, it is important to ensure that the sealing element used has an operating temperature that corresponds to the maximum temperature of the process.

- Devices with CSA approval are intended for indoor use
Devices are suitable for use in wet environments in accordance with IEC/EN 61010-1
- Protect housing against impact

5.1.2 Take switch point into consideration

The following are typical switch points, depending on the orientation of the point level switch.

Water +23 °C (+73 °F)

- i** Minimum distance between the tuning fork and the tank wall or pipe wall:
10 mm (0.39 in)

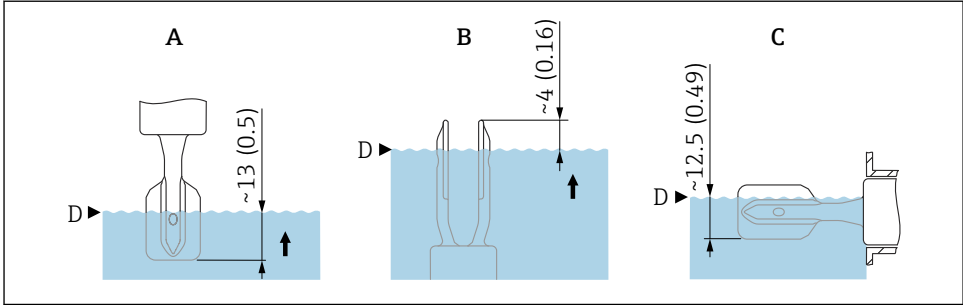

A0037915

3 Typical switch points. Unit of measurement mm (in)

- A Installation from above
- B Installation from below
- C Installation from the side
- D Switch point

5.1.3 Take viscosity into consideration

i Viscosity values

- Low viscosity: < 2 000 mPa·s
- High viscosity: > 2 000 to 10 000 mPa·s

Low viscosity

i Low viscosity, e.g. water: < 2 000 mPa·s

It is permitted to position the tuning fork within the installation socket.

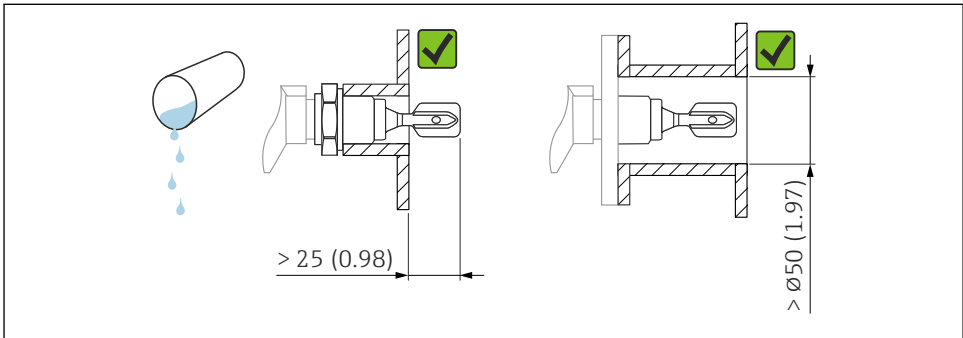

A0033297

4 Installation example for low-viscosity liquids. Unit of measurement mm (in)

High viscosity

NOTICE

Highly viscous liquids may cause switching delays.

- ▶ Make sure that the liquid can run off the tuning fork easily.
- ▶ Deburr the socket surface.



High viscosity, e.g. viscous oils: $\leq 10\,000$ mPa·s

The tuning fork must be located outside the installation socket!

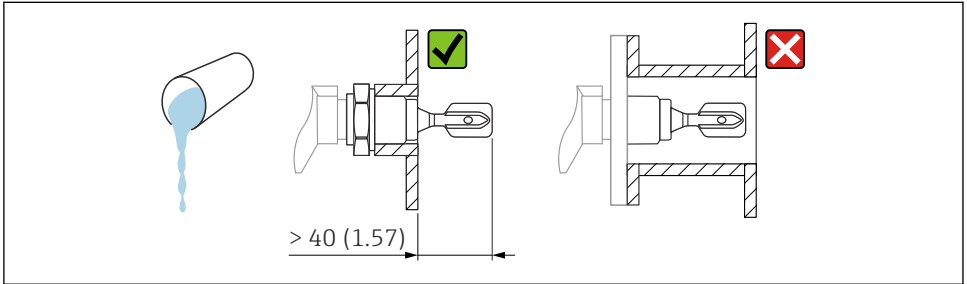

A0037348

5 Installation example for a highly viscous liquid. Unit of measurement mm (in)

5.1.4 Avoid buildup

- Use short installation sockets to ensure that the tuning fork projects freely into the vessel
- Leave sufficient distance between the buildup expected on the tank wall and the tuning fork

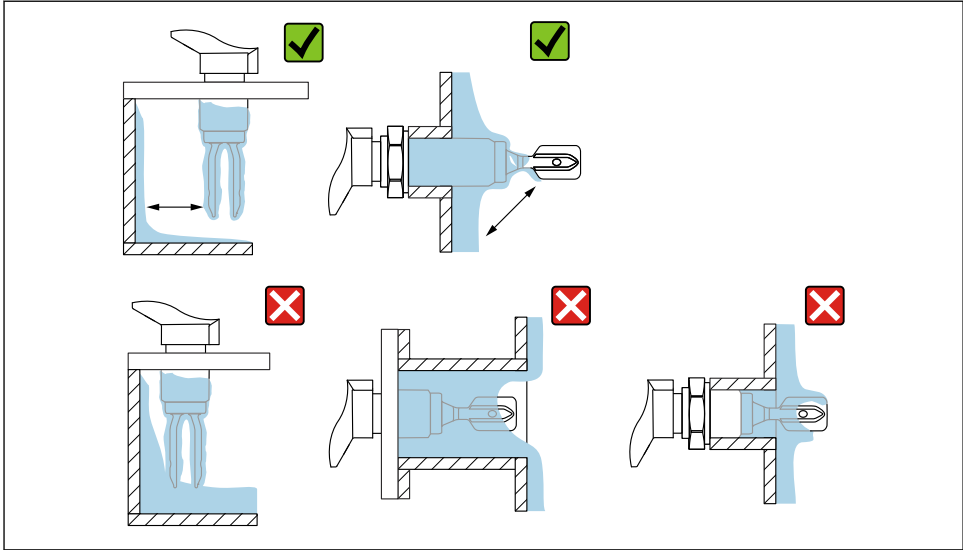

A0033239

6 Installation examples for a highly viscous process medium

5.1.5 Take clearance into consideration.

Allow sufficient clearance outside the tank for mounting and electrical connection.

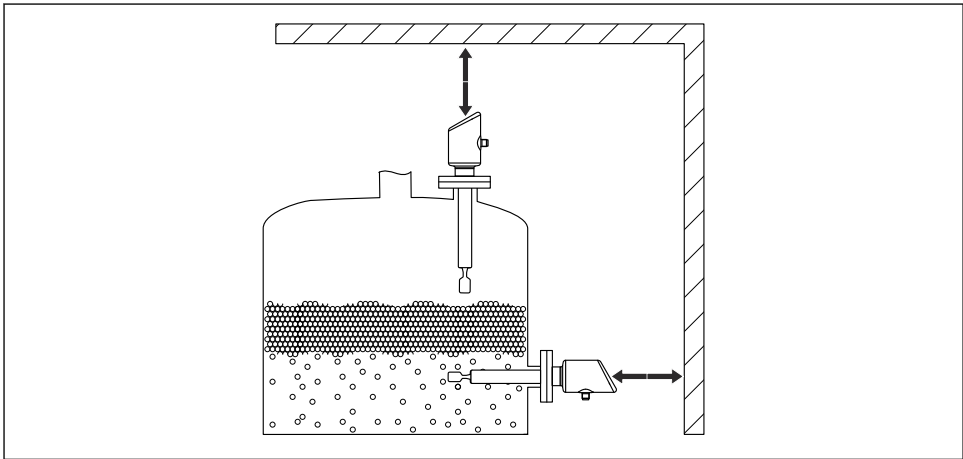

A0053359

7 Take clearance into consideration.

5.1.6 Support the device

Support the device in the event of severe dynamic load. Maximum lateral loading capacity of the pipe extensions and sensors: 75 Nm (55 lbf ft).

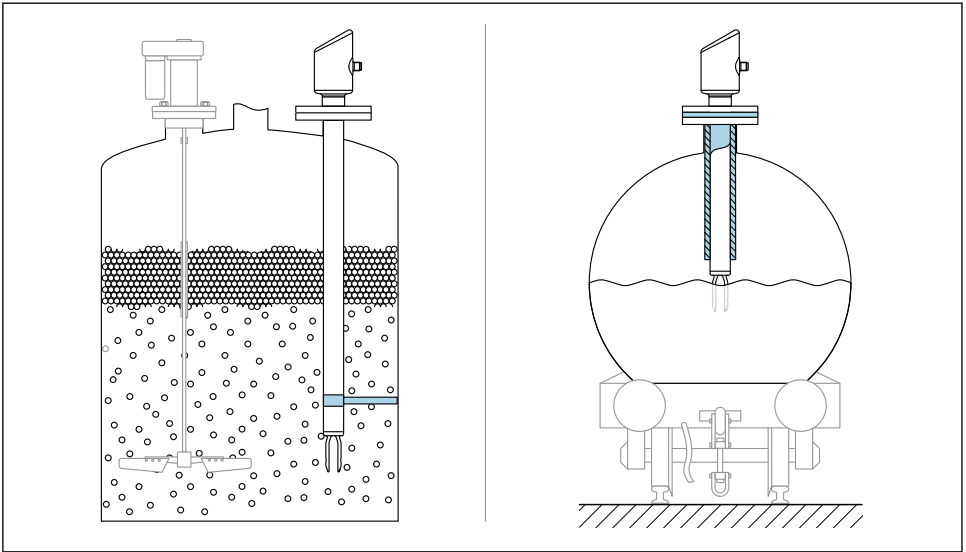

A0053109

8 Examples of support in the event of dynamic load

5.1.7 Weld-in adapter with leakage hole

Weld in the weld-in adapter in such a way that the leakage hole is pointing downwards. This enables any leaks to be detected quickly.

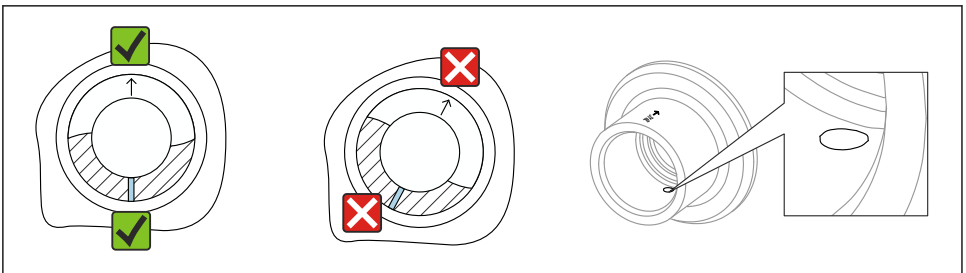

A0039230

9 Weld-in adapter with leakage hole

5.2 Mounting the device

5.2.1 Required tools

Open-ended wrench for sensor installation

5.2.2 Installation

Aligning the tuning fork using the marking

The tuning fork can be aligned using the marking in such a way that the medium drains off easily and buildup is avoided.

Markings on process connection:

Material specification, thread designation, circle, line or double line

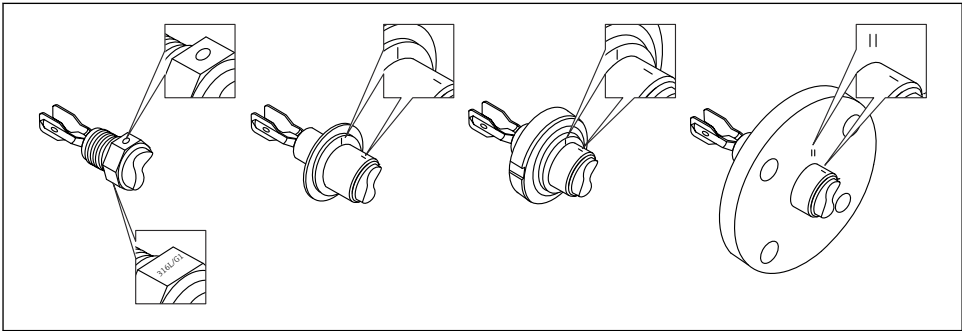

A0039125

 10 Position of the tuning fork when installed horizontally in the vessel using the marking

Installing the device in piping

- Flow velocity up to 5 m/s with a viscosity of 1 mPa·s and density of 1 g/cm³ (62.4 lb/ft³) (SGU).

Check for correct functioning in the event of other process medium conditions.

- The flow will not be significantly impeded if the tuning fork is correctly aligned and the marking is pointing in the direction of flow.
- The marking is visible when installed.

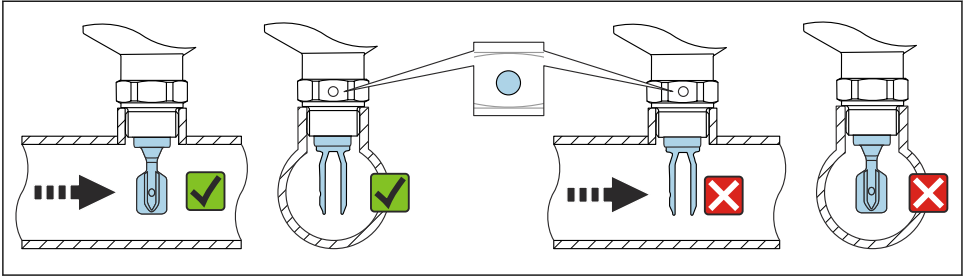

A0034851

11 Installation in pipes (take fork position and marking into consideration)

Screwing in the device (for process connections with thread)

- Turn by the hex bolt only, 15 to 30 Nm (11 to 22 lbf ft)
- Do not turn at the housing!

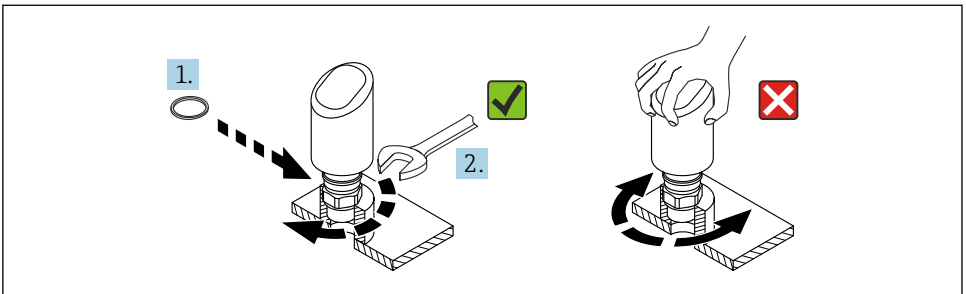

A0054233

12 Screwing in the device

5.3 Post-mounting check

- Is the device undamaged (visual inspection)?
- Are the measuring point identification and labeling correct (visual inspection)?
- Is the device properly secured?
- Does the device comply with the measuring point specifications?

For example:

- Process temperature
- Process pressure
- Ambient temperature
- Measuring range

6 Electrical connection

6.1 Connecting the device

6.1.1 Potential equalization

If necessary, establish potential equalization using the process connection or the grounding clamp supplied by the customer.

6.1.2 Supply voltage

12 to 30 V_{DC} on a direct current power unit

IO-Link communication is guaranteed only if the supply voltage is at least 18 V.



The power unit must be safety-approved (e.g. PELV, SELV, Class 2) and must comply with the relevant protocol specifications.

Protective circuits against reverse polarity, HF influences and overvoltage peaks are installed.

6.1.3 Power consumption

To meet device safety specifications according to the IEC/EN 61010 standard, the installation must ensure that the maximum current is limited to 500 mA.

6.1.4 Overvoltage protection

The device satisfies the IEC/DIN EN IEC 61326-1 product standard (Table 2 Industrial environment). Depending on the type of port (DC supply, input/output port) different test levels against transient overvoltages (IEC/DIN EN 61000-4-5 Surge) are applied according to IEC/DIN EN 61326-1: Test level on DC power ports and input/output ports is 1 000 V line to earth.

Overvoltage protection category

According to IEC/DIN EN 61010-1, the device is intended for use in overvoltage protection category II networks.

6.1.5 Range of adjustment

Switch points can be configured via IO-Link.

6.1.6 Switching capacity

- Switch status ON: $I_a \leq 200 \text{ mA}$ ¹⁾; Switch status OFF: $I_a < 0.1 \text{ mA}$ ²⁾
- Switch cycles: $> 1 \cdot 10^7$
- Voltage drop PNP: $\leq 2 \text{ V}$
- Overload protection: Automatic load testing of switching current;
 - Max. capacitive load: $1 \mu\text{F}$ at max. supply voltage (without resistive load)
 - Max. cycle duration: 0.5 s ; min. t_{on} : $40 \mu\text{s}$
 - Periodic disconnection from protective circuit in the event of overcurrent ($f = 1 \text{ Hz}$)

6.1.7 Terminal assignment

WARNING

Supply voltage might be connected!

Risk of electric shock and/or explosion

- ▶ Ensure that no supply voltage is applied when connecting.
- ▶ The supply voltage must match the specifications on the nameplate.
- ▶ A suitable circuit breaker should be provided for the device in accordance with IEC/EN 61010.
- ▶ The cables must be adequately insulated, with due consideration given to the supply voltage and the overvoltage category.
- ▶ The connecting cables must offer adequate temperature stability, with due consideration given to the ambient temperature.
- ▶ Protective circuits against reverse polarity, HF influences and overvoltage peaks are installed.

WARNING

An incorrect connection compromises electrical safety!

- ▶ Non-hazardous area: To meet device safety specifications according to the IEC/EN 61010 standard, the installation must ensure that the maximum current is limited to 500 mA.

NOTICE

Damage to analog input of PLC resulting from incorrect connection

- ▶ Do not connect the active PNP switch output of the device to the 4 to 20 mA input of a PLC.

Connect the device in the following order:

1. Check that the supply voltage corresponds to the supply voltage indicated on the nameplate.
2. Connect the device as indicated in the following diagram.
3. Switch on the supply voltage.

-
- 1) If the "1 x PNP + 4 to 20 mA" outputs are used at the same time, the switch output OUT1 can be loaded with up to 100 mA load current over the entire temperature range. The switching current may be up to 200 mA up to an ambient temperature of $50 \text{ }^\circ\text{C}$ ($122 \text{ }^\circ\text{F}$) and up to a process temperature of $85 \text{ }^\circ\text{C}$ ($185 \text{ }^\circ\text{F}$). If the "1 x PNP" or "2 x PNP" configuration is used, the switch outputs can be loaded with a total of up to 200 mA over the entire temperature range.
 - 2) Different for switch output OUT2, for switch status OFF: $I_a < 3.6 \text{ mA}$ and $U_a < 2 \text{ V}$ and for switch status ON: voltage drop PNP: $\leq 2.5 \text{ V}$

2-wire

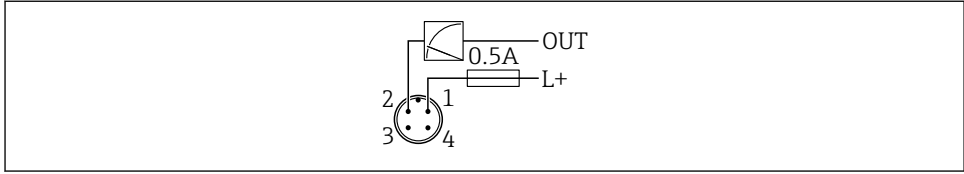

A0052660

- 1 Supply voltage L+, brown wire (BN)
- 2 OUT (L-), white wire (WH)

3-wire or 4-wire

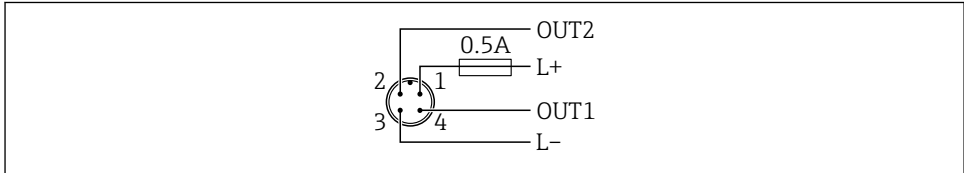

A0052457

- 1 Supply voltage L+, brown wire (BN)
- 2 Switch or analog output (OUT2), white wire (WH)
- 3 Supply voltage L-, blue wire (BU)
- 4 Switching or IO-Link output (OUT1), black wire (BK)

The functionality of output 1 and 2 can be configured.

Connection examples

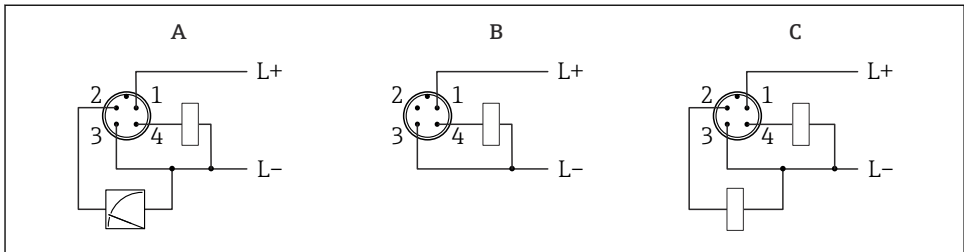

A0052458

- A 1 x PNP switch and analog output (default setting)
- B 1 x PNP switch output (current output must be deactivated. If the current output has not been deactivated, a message appears. In the case of onsite display: error is displayed. In the case of LED indicator: operating status LED permanently red.)
- C 2 x PNP switch output (set second output to switch output)

6.2 Ensuring the degree of protection

For mounted M12 connecting cable: IP66/68/69, NEMA type 4X/6P

NOTICE

Loss of IP protection class due to incorrect installation!

- ▶ The degree of protection only applies if the connecting cable used is plugged in and screwed tight.
- ▶ The degree of protection only applies if the connecting cable used is specified according to the intended protection class.

6.3 Post-connection check

- Is the device or cable undamaged (visual check)?
- Does the cable used comply with the requirements?
- Is the mounted cable strain-relieved?
- Is the screw connection properly mounted?
- Does the supply voltage match the specifications on the nameplate?
- No reverse polarity, terminal assignment correct?
- If power is supplied: Is the device ready for operation and is the operating status LED lit?

7 Operation options

See Operating Instructions.

8 Commissioning

8.1 Preliminaries



WARNING

Settings on the current output can result in a safety-related condition (e.g., product overflow)!

- ▶ Check current output settings.
- ▶ The setting of the current output depends on the setting in the **Measuring mode current output** parameter.

8.2 Installation and function check

Before commissioning the measuring point, check that the post-installation and post-connection checks have been performed:

-  "Post-mounting check" section
-  "Post-connection check" section

8.3 Switching on the device

Once the supply voltage has been switched on, the device adopts the normal mode after a maximum of 4 s. During the start-up phase, the outputs are in the same state as when switched off.

8.4 Overview of commissioning options

- Commissioning via LED indicator operating key
- Commissioning with the SmartBlue app
- Commissioning via FieldCare/DeviceCare/Field Xpert
- Commissioning via additional operating tools (AMS, PDM, etc.)

8.5 Commissioning via FieldCare/DeviceCare

1. Download IO-Link IODD Interpreter DTM: <http://www.endress.com/download>.
Download IODD: <https://ioddfinder.io-link.com/>.
2. Integrate the IODD (IO Device Description) in IODD Interpreter. Then start FieldCare and update the DTM catalog.

8.5.1 Establishing a connection via FieldCare, DeviceCare and FieldXpert

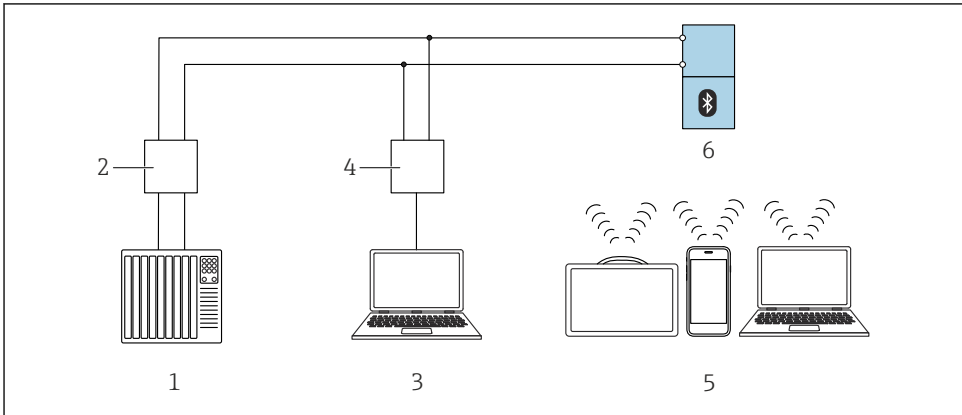

A0053130

13 Options for remote operation via IO-Link

- 1 PLC (programmable logic controller)
- 2 IO-Link master
- 3 Computer with operating tool e.g. DeviceCare/FieldCare)
- 4 FieldPort SFP20
- 5 Field Xpert SMT70/SMT77, smartphone or computer with operating tool (e.g. DeviceCare/FieldCare)
- 6 Transmitter

8.5.2 Information on the IODD

The following parameters are relevant for basic commissioning:

"Basic settings" submenu

- **Density setting** parameter
- **Safety function** parameter
 - **MIN** option
 - **MAX** option

8.5.3 Operation

See Operating Instructions.

8.6 Commissioning via additional operating tools (AMS, PDM, etc.)

Download the device-specific drivers: <https://www.endress.com/en/downloads>

For more details, see the help for the relevant operating tool.

8.7 Configuring the device

8.7.1 Configuring process monitoring

Digital process monitoring (switch output)

It is possible to select defined switch points and switchback points which act as NO or NC contacts depending on whether a window function or hysteresis function is configured.

Possible setting				Output (OUT1/OUT2)
Function (Config. Mode)	Invert (Config. Logic)	Switch points (Param.SP _x)	Hysteresis (Config. Hyst)	
Two point	High active (MIN)	SP1 (float32)	N/A	Normally open contact (NO ¹⁾)
		SP2 (float32)		
	Low active (MAX)	SP1 (float32)	N/A	Normally closed contact (NC ²⁾)
		SP2 (float32)		
Window	High active	SP1 (float32)	Hyst (float32)	Normally open contact (NO ¹⁾)
		SP2 (float32)		
	Low active	SP1 (float32)	Hyst (float32)	Normally closed contact (NC ²⁾)
		SP2 (float32)		
Single point	High active (MIN)	SP1 (float32)	Hyst (float32)	Normally open contact (NO ¹⁾)
	Low active (MAX)	SP2 (float32)	Hyst (float32)	Normally closed contact (NC ²⁾)

1) NO = normally open

2) NC = normally closed

If the device is restarted within the given hysteresis, the switch output is open (0 V present at the output).

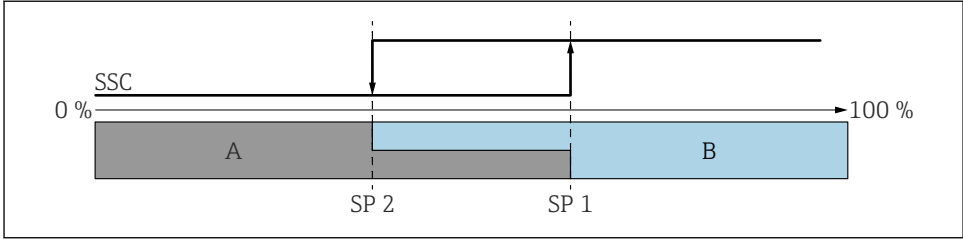

A0054230

14 SSC, Two-point

SP 2 Switch point with lower measured value

SP 1 Switch point with higher measured value

A Inactive

B Active

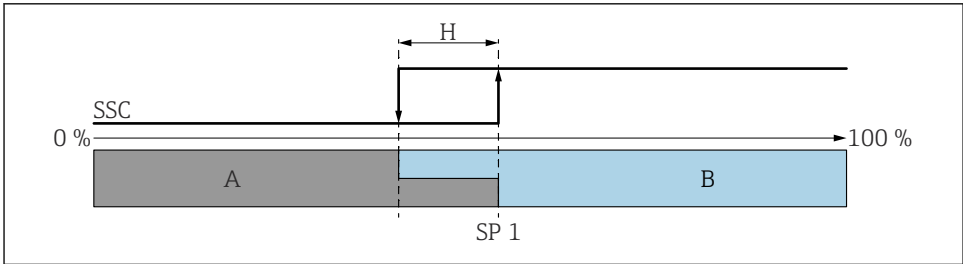

A0054231

15 SSC, single point

H Hysteresis

SP 1 Switch point

A Inactive

B Active

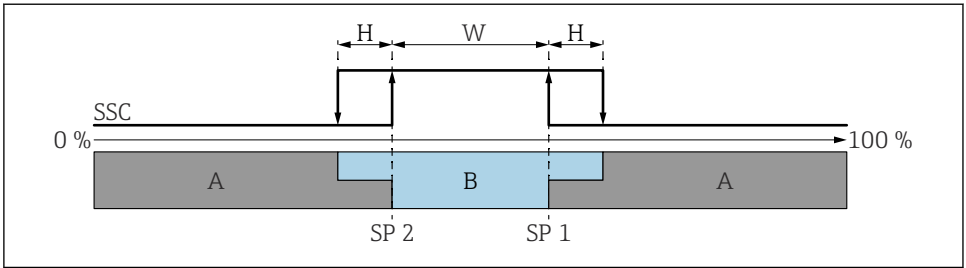

A0054232

16 SSC, window

H Hysteresis

W Window

$SP\ 2$ Switch point with lower measured value

$SP\ 1$ Switch point with higher measured value

A Inactive

B Active

Teach process (IODD)

A switch point is not entered manually for the teach process, but is defined by assigning the current process value of a switching signal channel (SSC) to the switch point. To assign the process value, the corresponding switch point, e.g. "SP 1", is selected in the next step in the "System command" parameter.

By activating "Teach SP 1" or "Teach SP 2", the current process measured values can be adopted as switch point SP 1 or SP 2. The hysteresis is entered manually for both!

8.8 Protecting settings from unauthorized access

8.8.1 Software locking or unlocking

Locking via password in FieldCare/DeviceCare/SmartBlue app

Access to parameter configuration of the device can be locked by assigning a password. When the device is delivered from the factory, the user role is set to **Maintenance** option. The device parameters can be fully configured with the **Maintenance** option user role. Afterwards, access to the configuration can be locked by assigning a password. The **Maintenance** option switches to the **Operator** option as a result of this locking. The configuration can be accessed by entering the password.

The password is defined under:

System menu **User management** submenu

The user role is changed from the **Maintenance** option to **Operator** option under:

System → User management

Deactivating the lock via FieldCare/DeviceCare/SmartBlue app

After entering the password, you can enable parameter configuration of the device as an **Operator** option with the password. The user role then changes to **Maintenance** option.

If necessary, the password can be deleted in User management: System → User management



71647157

www.addresses.endress.com
