

Operating Instructions

Liquiphant FTL43

HART

Vibronic
Point level switch for liquids





A0023555

- Make sure the document is stored in a safe place such that it is always available when working on or with the device
- Avoid danger to individuals or the facility: read the "Basic safety instructions" section carefully, as well as all other safety instructions in the document that are specific to working procedures

The manufacturer reserves the right to modify technical data without prior notice. The Endress+Hauser sales organization will supply you with current information and updates to these instructions.

Table of contents

1	About this document	5	9.2	Installation and function check	26
1.1	Document function	5	9.3	Overview of commissioning options	26
1.2	Symbols	5	9.4	Commissioning via FieldCare/DeviceCare	26
1.3	List of abbreviations	6	9.5	Commissioning via additional operating tools (AMS, PDM, etc.)	27
1.4	Documentation	6	9.6	Configuring the device address via software ..	27
1.5	Registered trademarks	6	9.7	Simulation	27
2	Basic safety instructions	7	9.8	Protecting settings from unauthorized access	28
2.1	Requirements for the personnel	7	10	Operation	28
2.2	Intended use	7	10.1	Reading off the device locking status	28
2.3	Workplace safety	7	10.2	Reading off measured values	28
2.4	Operational safety	8	10.3	Adapting the device to process conditions	29
2.5	Product security	8	10.4	Heartbeat Technology (optional)	29
2.6	IT security	8	10.5	Proof test for WHG devices (optional)	31
2.7	Device-specific IT security	8	10.6	Displaying the measured value history	31
3	Product description	9	11	Diagnostics and troubleshooting ...	31
3.1	Product design	9	11.1	General troubleshooting	31
4	Incoming acceptance and product identification	10	11.2	Diagnostic information on operating status LED	33
4.1	Incoming acceptance	10	11.3	Diagnostic event in the operating tool	34
4.2	Product identification	10	11.4	Adapting the diagnostic information	34
4.3	Storage and transport	11	11.5	Pending diagnostic messages	34
5	Mounting	11	11.6	Diagnostic list	34
5.1	Mounting requirements	12	11.7	Event logbook	37
5.2	Mounting the device	15	11.8	Resetting the device	38
5.3	Post-mounting check	16	11.9	Device information	38
6	Electrical connection	17	11.10	Firmware history	39
6.1	Connecting the device	17	12	Maintenance	39
6.2	Ensuring the degree of protection	19	12.1	Maintenance work	39
6.3	Post-connection check	19	13	Repair	39
7	Operation options	20	13.1	General information	39
7.1	Overview of operation options	20	13.2	Return	39
7.2	Structure and function of the operating menu	20	13.3	Disposal	40
7.3	Access to operating menu via LED indicator ..	21	14	Accessories	40
7.4	Access to the operating menu via the operating tool	23	14.1	Device-specific accessories	40
8	System integration	25	14.2	DeviceCare SFE100	41
8.1	Overview of device description files	25	14.3	FieldCare SFE500	41
8.2	Measured variables via HART protocol	25	14.4	Device Viewer	41
9	Commissioning	26	14.5	Field Xpert SMT70	41
9.1	Preliminaries	26	14.6	Field Xpert SMT77	41
			14.7	SmartBlue app	41
			15	Technical data	42
			15.1	Output	42
			15.2	Environment	44

Index..... **46**

1 About this document

1.1 Document function

These Operating Instructions contain all the information required in the various life cycle phases of the device: from product identification, incoming acceptance and storage, to installation, connection, operation and commissioning, through to troubleshooting, maintenance and disposal.

1.2 Symbols

1.2.1 Safety symbols

 DANGER

This symbol alerts you to a dangerous situation. Failure to avoid this situation will result in serious or fatal injury.

 WARNING

This symbol alerts you to a dangerous situation. Failure to avoid this situation can result in serious or fatal injury.

 CAUTION

This symbol alerts you to a dangerous situation. Failure to avoid this situation can result in minor or medium injury.

NOTICE

This symbol contains information on procedures and other facts which do not result in personal injury.

1.2.2 Tool symbols

 Open-ended wrench

1.2.3 Communication-specific symbols

Bluetooth®: 

Wireless data transmission between devices over a short distance.

1.2.4 Symbols for certain types of Information

Permitted: 

Procedures, processes or actions that are permitted.

Forbidden: 

Procedures, processes or actions that are forbidden.

Additional information: 

Reference to documentation: 

Reference to page: 

Series of steps: [1.](#), [2.](#), [3.](#)

Result of an individual step: 

1.2.5 Symbols in graphics

Item numbers: 1, 2, 3 ...

Series of steps: [1.](#), [2.](#), [3.](#)

Views: A, B, C, ...

1.3 List of abbreviations

PN

Nominal pressure

MWP

Maximum working pressure

The MWP is indicated on the nameplate.

DTM

Device Type Manager

Operating tool

The term "operating tool" is used in place of the following operating software:

- FieldCare / DeviceCare, for operation via HART communication and PC
- SmartBlue app for operation using an Android or iOS smartphone or tablet

PLC

Programmable logic controller (PLC)

1.4 Documentation

 For an overview of the scope of the associated Technical Documentation, refer to the following:

- *Device Viewer* (www.endress.com/deviceviewer): Enter the serial number from the nameplate
- *Endress+Hauser Operations app*: Enter serial number from nameplate or scan matrix code on nameplate.

1.5 Registered trademarks

Apple®

Apple, the Apple logo, iPhone, and iPod touch are trademarks of Apple Inc., registered in the U.S. and other countries. App Store is a service mark of Apple Inc.

Android®

Android, Google Play and the Google Play logo are trademarks of Google Inc.

Bluetooth®

The *Bluetooth®* word mark and logos are registered trademarks owned by the Bluetooth SIG, Inc. and any use of such marks by Endress+Hauser is under license. Other trademarks and trade names are those of their respective owners.

HART®

Registered trademark of the FieldComm Group, Austin, Texas USA

2 Basic safety instructions

2.1 Requirements for the personnel

The personnel for installation, commissioning, diagnostics and maintenance must fulfill the following requirements:

- ▶ Trained, qualified specialists must have a relevant qualification for this specific function and task.
- ▶ Are authorized by the plant owner/operator.
- ▶ Are familiar with federal/national regulations.
- ▶ Before starting work, read and understand the instructions in the manual and supplementary documentation as well as the certificates (depending on the application).
- ▶ Follow instructions and comply with basic conditions.

The operating personnel must fulfill the following requirements:

- ▶ Are instructed and authorized according to the requirements of the task by the facility's owner-operator.
- ▶ Follow the instructions in this manual.

2.2 Intended use

The device described in this manual is intended only for the level measurement of liquids.

Incorrect use

The manufacturer is not liable for damage caused by improper or unintended use.

Avoid mechanical damage:

- ▶ Do not touch or clean device surfaces with pointed or hard objects.

Clarification for borderline cases:

- ▶ For special media and fluids for cleaning, Endress+Hauser is glad to provide assistance in verifying the corrosion resistance of fluid-wetted materials, but does not accept any warranty or liability.

Residual risks

Due to the transfer of heat from the process and power dissipation within the electronics, the temperature of the housing may increase to up to 80 °C (176 °F) during operation. When in operation, the sensor can reach a temperature close to the medium temperature.

Danger of burns from contact with surfaces!

- ▶ In the event of elevated fluid temperatures, ensure protection against contact to prevent burns.

2.3 Workplace safety

When working on and with the device:

- ▶ Wear the required personal protective equipment as per national regulations.
- ▶ Switch off the supply voltage before connecting the device.

2.4 Operational safety

Risk of injury!

- ▶ Operate the device only if it is in proper technical condition, free from errors and faults.
- ▶ The operator is responsible for trouble-free operation of the device.

Modifications to the device

Unauthorized modifications to the device are not permitted and can lead to unforeseeable dangers:

- ▶ If modifications are nevertheless required, consult with the manufacturer.

Repair

To ensure continued operational safety and reliability:

- ▶ Only use original accessories.

Hazardous area

To eliminate the risk of danger to persons or the facility when the device is used in the hazardous area (e.g. explosion protection, pressure equipment safety):

- ▶ Check the nameplate to verify if the device ordered can be put to its intended use in the hazardous area.
- ▶ Comply with the instructions in the separate supplementary documentation, which is an integral part of this manual.

2.5 Product security

This state-of-the-art device is designed and tested in accordance with good engineering practice to meet operational safety standards. It left the factory in a condition in which it is safe to operate.

The device fulfills general safety requirements and legal requirements. It also complies with the EU directives listed in the device-specific EU Declaration of Conformity. Endress+Hauser confirms this fact by affixing the CE mark.

2.6 IT security

Our warranty is valid only if the product is installed and used as described in the Operating Instructions. The product is equipped with security mechanisms to protect it against any inadvertent changes to the settings.

IT security measures, which provide additional protection for the product and associated data transfer, must be implemented by the operators themselves in line with their security standards.

2.7 Device-specific IT security

The device offers specific functions to support protective measures by the operator. These functions can be configured by the user and guarantee greater in-operation safety if used correctly. The user role can be changed with an access code (applies to operation via Bluetooth or FieldCare, DeviceCare or asset management tools (e.g. AMS, PDM)).

2.7.1 Access via Bluetooth® wireless technology

Secure signal transmission via Bluetooth® wireless technology uses an encryption method tested by the Fraunhofer Institute.

- Without the SmartBlue app, the device is not visible via Bluetooth® wireless technology.
- Only one point-to-point connection is established between the device and a smartphone or tablet.
- The Bluetooth® wireless technology interface can be disabled via onsite operation or via SmartBlue.

3 Product description

Point level switch for all liquids, for minimum or maximum detection in tanks, vessels and pipes.

3.1 Product design

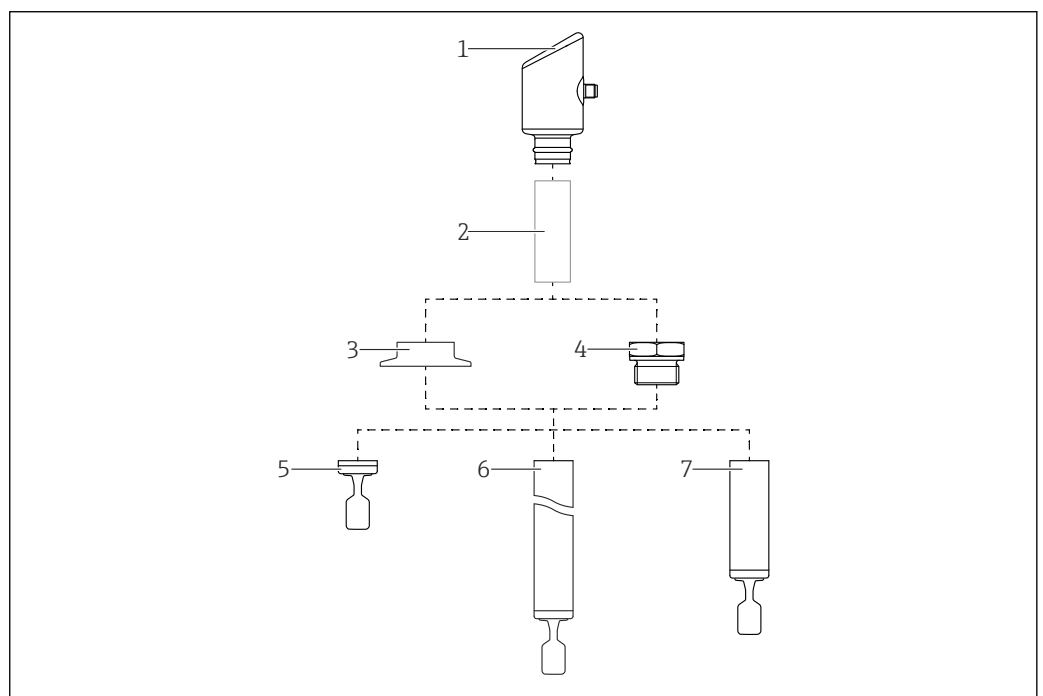

A0053358

1 Product design

- 1 Housing with electronics module
- 2 Temperature spacer, pressure-tight feedthrough (second line of defense), optional
- 3 Process connection, e.g. clamp/Tri-Clamp
- 4 Process connection, e.g. thread
- 5 Compact probe version with tuning fork
- 6 Pipe extension probe with tuning fork
- 7 Short pipe version of probe with tuning fork

4 Incoming acceptance and product identification

4.1 Incoming acceptance

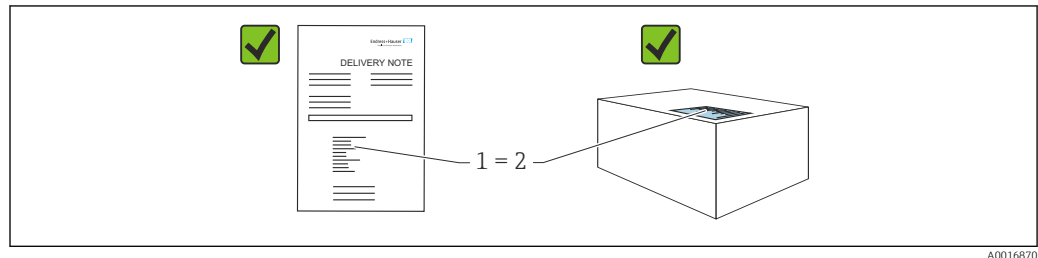

Check the following during incoming acceptance:

- Is the order code on the delivery note (1) identical to the order code on the product sticker (2)?
- Are the goods undamaged?
- Do the data on the nameplate correspond to the order specifications and the delivery note?
- Is the documentation provided?
- If required (see nameplate), are the Safety Instructions (XA) provided?



If one of these conditions is not met, please contact the manufacturer's sales office.

4.2 Product identification

The following options are available for identification of the device:

- Nameplate specifications
- Order code with breakdown of the device features on the delivery note
- Enter the serial numbers from the nameplates in *Device Viewer* (www.endress.com/deviceviewer): all the information about the device is displayed.

4.2.1 Nameplate

The information that is required by law and is relevant to the device is shown on the nameplate, e.g.:

- Manufacturer identification
- Order number, extended order code, serial number
- Technical data, degree of protection
- Firmware version, hardware version
- Approval-specific information
- DataMatrix code (information about the device)

Compare the data on the nameplate with your order.

4.2.2 Manufacturer address

Endress+Hauser SE+Co. KG
 Hauptstraße 1
 79689 Maulburg, Germany
 Place of manufacture: See nameplate.

4.3 Storage and transport

4.3.1 Storage conditions

- Use the original packaging
- Store the device in clean and dry conditions and protect from damage caused by shocks

Storage temperature

-40 to +85 °C (-40 to +185 °F)

4.3.2 Transporting the product to the measuring point

⚠ WARNING

Incorrect transport!

Housing and tuning fork may become damaged, and there is a risk of injury.

- ▶ Transport the device to the measuring point in the original packaging.
- ▶ Hold the device by the housing, temperature spacer, process connection or extension pipe.
- ▶ Do not bend, shorten or extend the tuning fork.

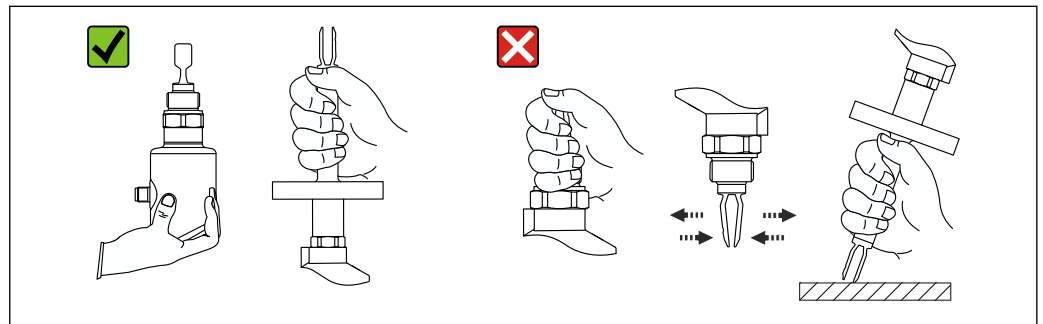

2 Handling the device

A0053361

5 Mounting

- Any orientation for compact version or version with a tube length up to approx. 500 mm (19.7 in)
- Vertical orientation from above for device with long pipe
- Minimum distance between the tuning fork and the tank wall or pipe wall: 10 mm (0.39 in)

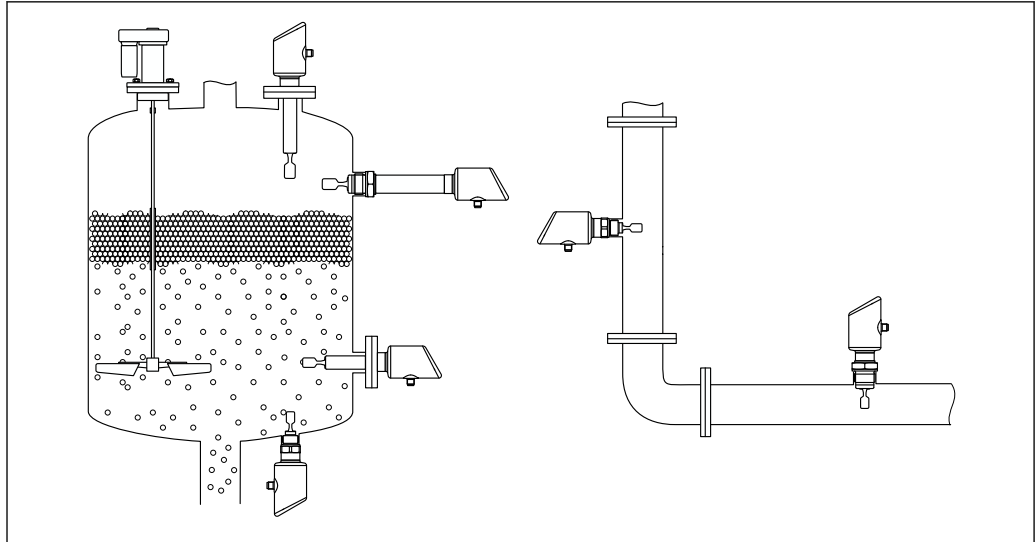

A0053113

3 Installation examples for a vessel, tank or pipe

5.1 Mounting requirements

5.1.1 Mounting instructions

i During installation, it is important to ensure that the sealing element used has an operating temperature that corresponds to the maximum temperature of the process.

- Devices with CSA approval are intended for indoor use
Devices are suitable for use in wet environments in accordance with IEC/EN 61010-1
- Protect housing against impact

5.1.2 Take switch point into consideration

The following are typical switch points, depending on the orientation of the point level switch.

Water +23 °C (+73 °F)

i Minimum distance between the tuning fork and the tank wall or pipe wall:
10 mm (0.39 in)

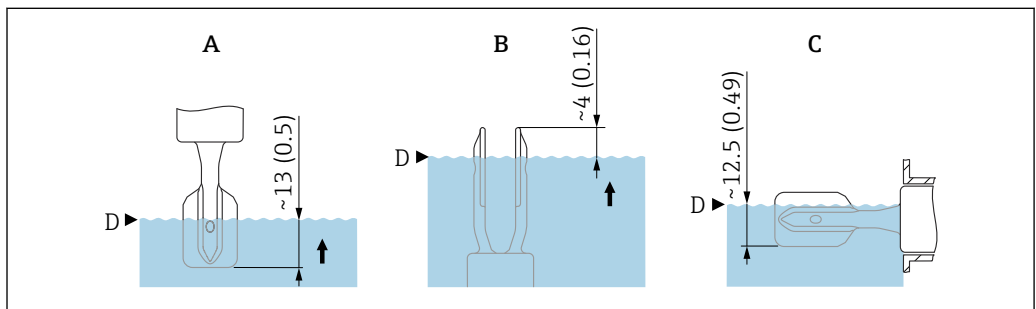

A0037915

4 Typical switch points. Unit of measurement mm (in)

- A Installation from above
- B Installation from below
- C Installation from the side
- D Switch point

5.1.3 Take viscosity into consideration

- i** Viscosity values
- Low viscosity : < 2 000 mPa·s
 - High viscosity: > 2 000 to 10 000 mPa·s

Low viscosity

- i** Low viscosity, e.g. water: < 2 000 mPa·s
- It is permitted to position the tuning fork within the installation socket.

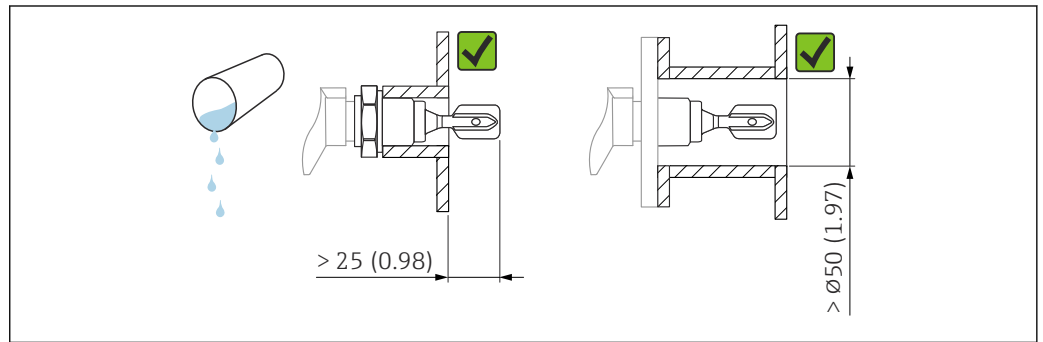

5 Installation example for low-viscosity liquids. Unit of measurement mm (in)

High viscosity

NOTICE

Highly viscous liquids may cause switching delays.

- ▶ Make sure that the liquid can run off the tuning fork easily.
- ▶ Deburr the socket surface.

- i** High viscosity, e.g. viscous oils: ≤ 10 000 mPa·s
- The tuning fork must be located outside the installation socket!

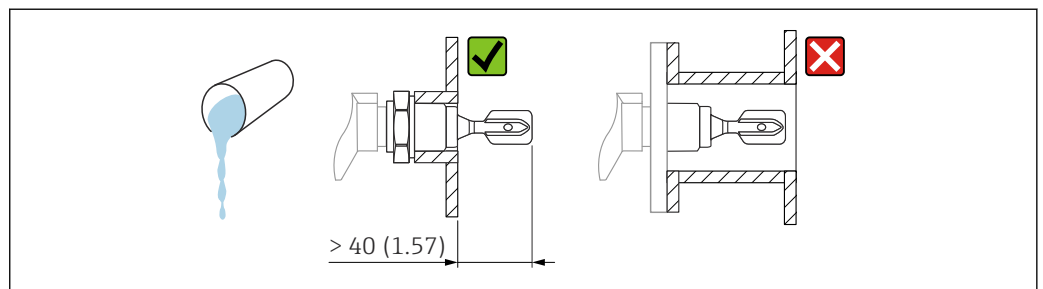

6 Installation example for a highly viscous liquid. Unit of measurement mm (in)

5.1.4 Avoid buildup

- Use short installation sockets to ensure that the tuning fork projects freely into the vessel
- Leave sufficient distance between the buildup expected on the tank wall and the tuning fork

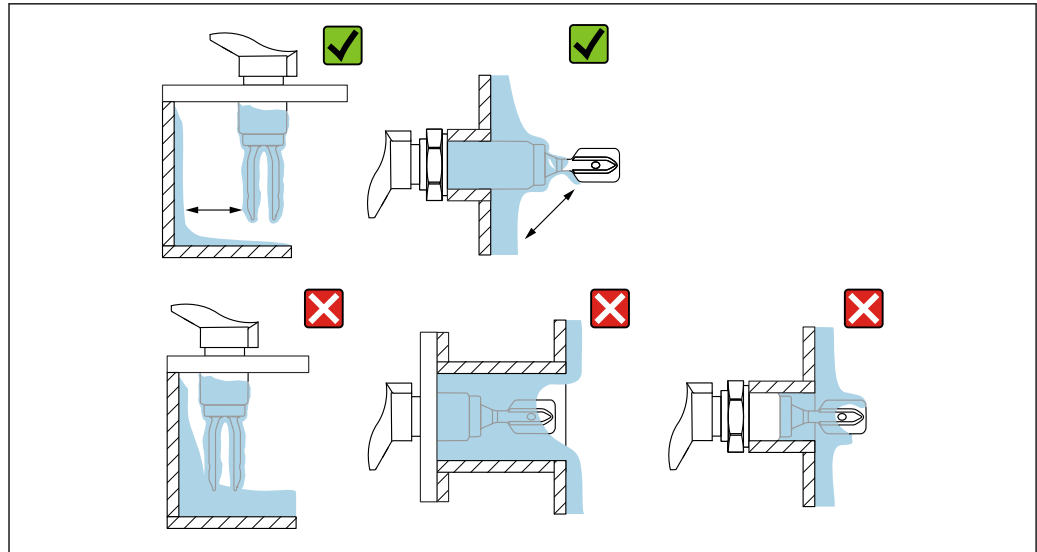

A0033239

7 Installation examples for a highly viscous process medium

5.1.5 Take clearance into consideration.

Allow sufficient clearance outside the tank for mounting and electrical connection.

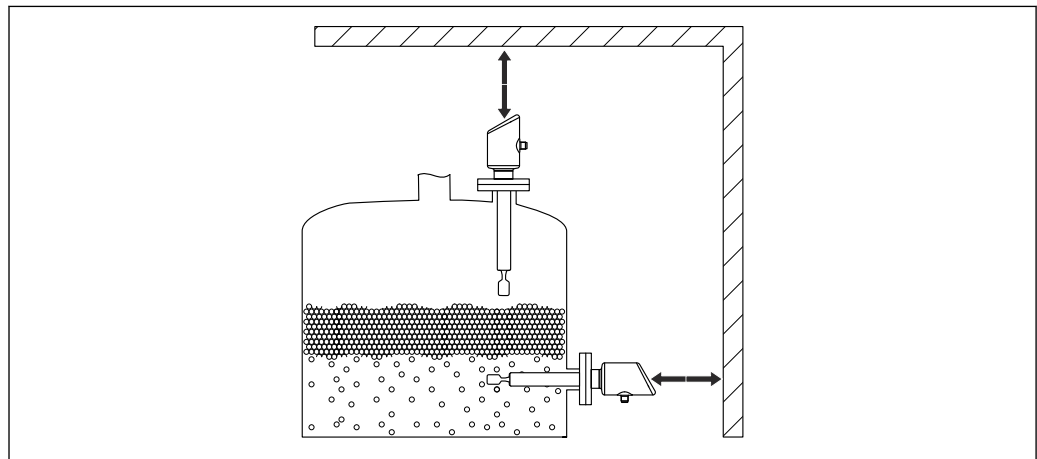

A0053359

8 Take clearance into consideration.

5.1.6 Support the device

Support the device in the event of severe dynamic load. Maximum lateral loading capacity of the pipe extensions and sensors: 75 Nm (55 lbf ft).

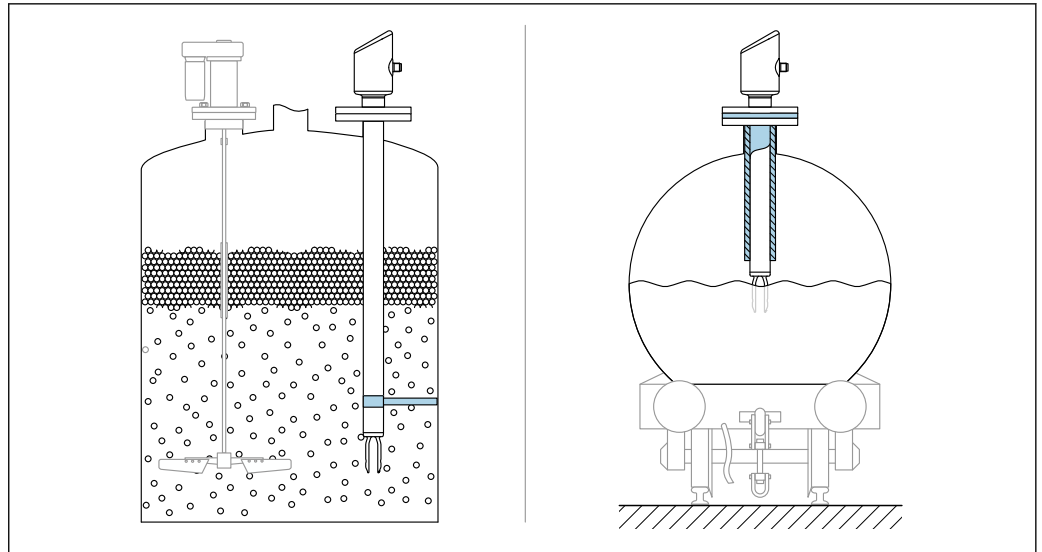

A0053109

9 Examples of support in the event of dynamic load

5.1.7 Weld-in adapter with leakage hole

Weld in the weld-in adapter in such a way that the leakage hole is pointing downwards. This enables any leaks to be detected quickly.

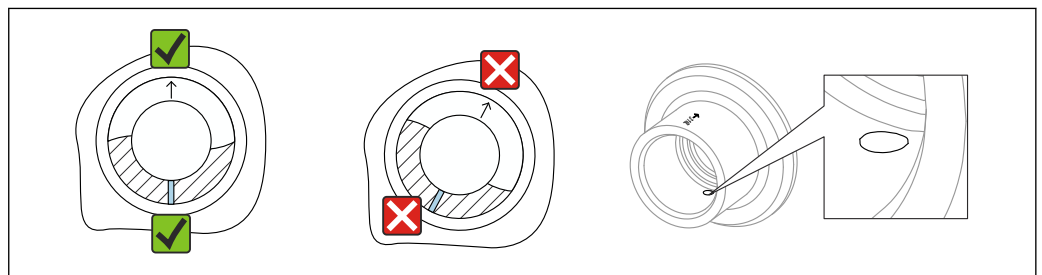

A0039230

10 Weld-in adapter with leakage hole

5.2 Mounting the device

5.2.1 Required tools

Open-ended wrench for sensor installation

5.2.2 Installation

Aligning the tuning fork using the marking

The tuning fork can be aligned using the marking in such a way that the medium drains off easily and buildup is avoided.

Markings on process connection:

Material specification, thread designation, circle, line or double line

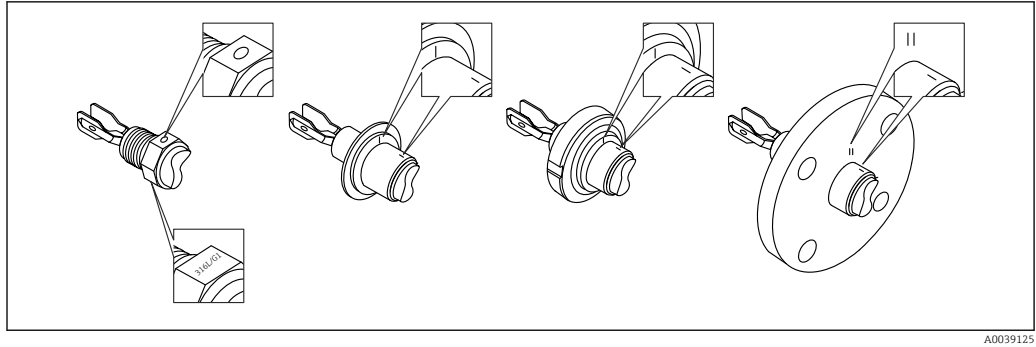

11 Position of the tuning fork when installed horizontally in the vessel using the marking

Installing the device in piping

- Flow velocity up to 5 m/s with a viscosity of 1 mPa·s and density of 1 g/cm³ (62.4 lb/ft³) (SGU).
Check for correct functioning in the event of other process medium conditions.
- The flow will not be significantly impeded if the tuning fork is correctly aligned and the marking is pointing in the direction of flow.
- The marking is visible when installed.

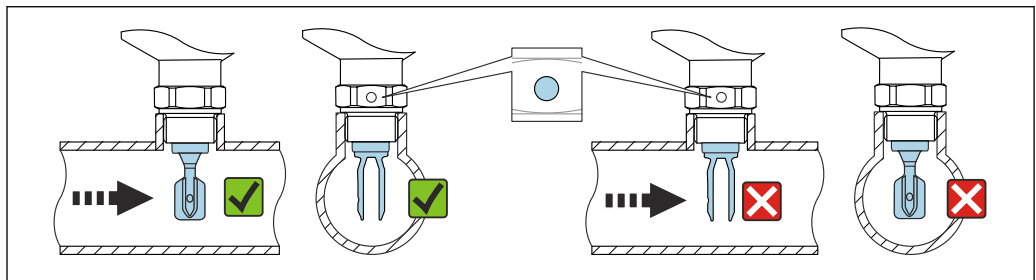

12 Installation in pipes (take fork position and marking into consideration)

Screwing in the device (for process connections with thread)

- Turn by the hex bolt only, 15 to 30 Nm (11 to 22 lbf ft)
- Do not turn at the housing!

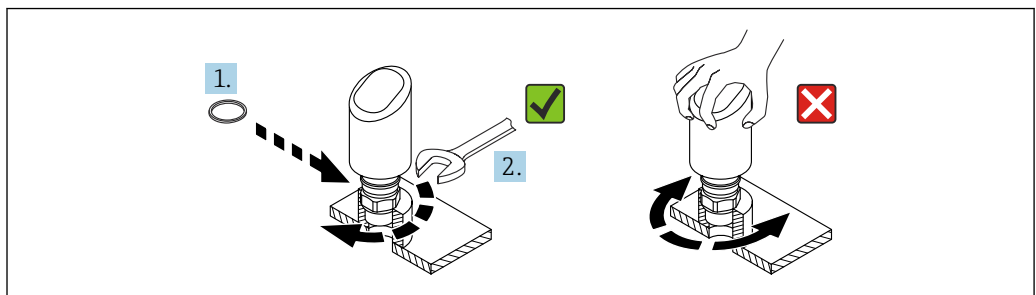

13 Screwing in the device

5.3 Post-mounting check

- Is the device undamaged (visual inspection)?
- Are the measuring point identification and labeling correct (visual inspection)?

- Is the device properly secured?
- Does the device comply with the measuring point specifications?

For example:

- Process temperature
- Process pressure
- Ambient temperature
- Measuring range

6 Electrical connection

6.1 Connecting the device

6.1.1 Potential equalization

If necessary, establish potential equalization using the process connection or the grounding clamp supplied by the customer.

6.1.2 Supply voltage

12 to 30 V_{DC} on a direct current power unit



The power unit must be safety-approved (e.g. PELV, SELV, Class 2) and must comply with the relevant protocol specifications.

For 4 to 20 mA, the same requirements apply as for HART. A galvanically isolated active barrier must be used for devices approved for use in explosion hazardous areas.

Protective circuits against reverse polarity, HF influences and overvoltage peaks are installed.

6.1.3 Power consumption

- Non-hazardous area: To meet device safety specifications according to the IEC/EN 61010 standard, the installation must ensure that the maximum current is limited to 500 mA.
- Hazardous area: The maximum current is restricted to $I_i = 100$ mA by the transmitter power supply unit when the device is used in an intrinsically safe circuit (Ex ia).

6.1.4 4 to 20 mA HART

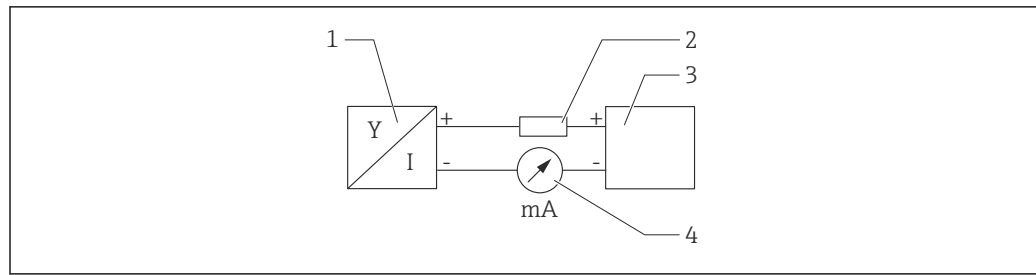

14 Block diagram of HART connection

- 1 Device with HART communication
- 2 HART communication resistor
- 3 Power supply
- 4 Multimeter or ammeter

i The HART communication resistor of 250 Ω in the signal line is always necessary in the case of a low-impedance power supply.

Take the voltage drop into consideration:

Maximum 6 V for a communication resistor of 250 Ω

6.1.5 Overvoltage protection

The device satisfies the IEC/DIN EN IEC 61326-1 product standard (Table 2 Industrial environment). Depending on the type of port (DC supply, input/output port) different test levels against transient overvoltages (IEC/DIN EN 61000-4-5 Surge) are applied according to IEC/DIN EN 61326-1: Test level on DC power ports and input/output ports is 1000 V line to earth.

Overvoltage protection category

According to IEC/DIN EN 61010-1, the device is intended for use in overvoltage protection category II networks.

6.1.6 Terminal assignment

WARNING

Supply voltage might be connected!

Risk of electric shock and/or explosion

- ▶ Ensure that no supply voltage is applied when connecting.
- ▶ The supply voltage must match the specifications on the nameplate.
- ▶ A suitable circuit breaker should be provided for the device in accordance with IEC/EN 61010.
- ▶ The cables must be adequately insulated, with due consideration given to the supply voltage and the overvoltage category.
- ▶ The connecting cables must offer adequate temperature stability, with due consideration given to the ambient temperature.
- ▶ Protective circuits against reverse polarity, HF influences and overvoltage peaks are installed.

⚠ WARNING**An incorrect connection compromises electrical safety!**

- ▶ Non-hazardous area: To meet device safety specifications according to the IEC/EN 61010 standard, the installation must ensure that the maximum current is limited to 500 mA.
- ▶ Hazardous area: The maximum current is restricted to $I_i = 100$ mA by the transmitter power supply unit when the device is used in an intrinsically safe circuit (Ex ia).
- ▶ When using the device in hazardous areas, comply with the corresponding national standards and the information in the Safety Instructions (XAs).
- ▶ All explosion-protection information is provided in separate explosion-protection (Ex) documentation. This Ex documentation can be requested. The Ex documentation is supplied as standard with all devices approved for use in explosion hazardous areas.

Connect the device in the following order:

1. Check that the supply voltage corresponds to the supply voltage indicated on the nameplate.
2. Connect the device as indicated in the following diagram.
3. Switch on the supply voltage.

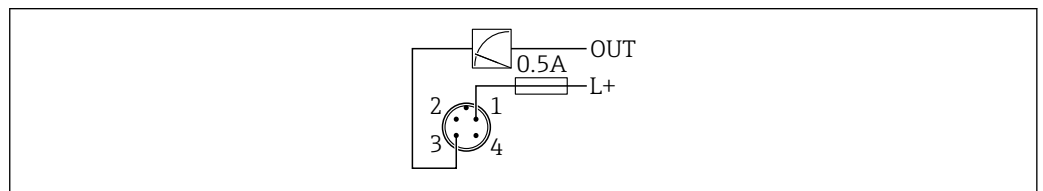
2-wire

- 1 Supply voltage L+, brown wire (BN)
 3 OUT (L-), blue wire (BU)

6.2 Ensuring the degree of protection

For mounted M12 connecting cable: IP66/68/69, NEMA type 4X/6P

NOTICE**Loss of IP protection class due to incorrect installation!**

- ▶ The degree of protection only applies if the connecting cable used is plugged in and screwed tight.
- ▶ The degree of protection only applies if the connecting cable used is specified according to the intended protection class.

6.3 Post-connection check

- Is the device or cable undamaged (visual check)?
- Does the cable used comply with the requirements?
- Is the mounted cable strain-relieved?
- Is the screw connection properly mounted?
- Does the supply voltage match the specifications on the nameplate?
- No reverse polarity, terminal assignment correct?
- If power is supplied: Is the device ready for operation and is the operating status LED lit?

7 Operation options

7.1 Overview of operation options

- Operation via LED indicator operating key
- Operation via Bluetooth®
- Operation via Endress+Hauser operating tool
- Operation via handheld, Fieldcare, DeviceCare, AMS and PDM

7.2 Structure and function of the operating menu

The complete operating menu is available via the operating tools (FieldCare, DeviceCare, SmartBlue) in order to make more complex settings on the device.

Wizards help the user to commission the various applications. The user is guided through the individual configuration steps.

7.2.1 Overview of the operating menu

"Guidance" menu

The Guidance main menu contains functions that enable the user to carry out basic tasks quickly, e.g. commissioning. This menu primarily consists of guided wizards and special functions covering multiple areas.

"Diagnostics" menu

Diagnostic information and settings as well as help for troubleshooting.

"Application" menu

Functions for detailed adjustment of the process for optimum integration of the device into the application.

"System" menu

System settings for device management, user administration or safety.

7.2.2 User roles and related access authorization

This device supports 2 user roles: **Maintenance** and **Operator**

- The **Maintenance** user role (as delivered to customer) has read/write access.
- The **Operator** user role has read access only.

The current user role is displayed in the main menu.

The device parameters can be fully configured with the **Maintenance** user role. Afterwards, access to the configuration can be locked by assigning a password. This password acts as an access code and protects device configuration from unauthorized access.

Blocking changes the **Maintenance** user role to the **Operator** user role. The configuration can be accessed again by entering the access code.

If an incorrect access code is entered, the user obtains the access rights of the **Operator** role.

Assign password, change user role:

- ▶ Navigation: System → User management

7.3 Access to operating menu via LED indicator

7.3.1 Overview

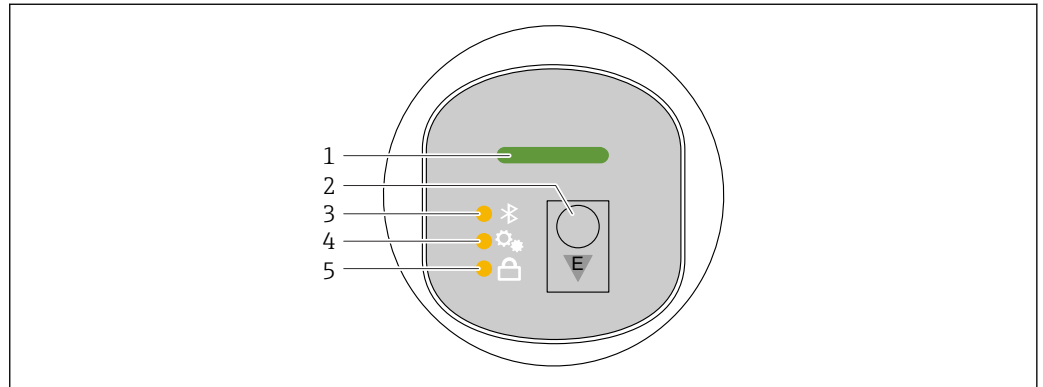

A0052426

- 1 Operating status LED
- 2 Operating key "E"
- 3 Bluetooth LED
- 4 Trigger proof test or function test LED
- 5 Keypad lock LED



Operation via the LED indicator is not possible if the Bluetooth connection is enabled.

Operating status LED (1)

See diagnostic events section.

Bluetooth LED (3)

- LED lit: Bluetooth enabled
- LED not lit: Bluetooth disabled or Bluetooth option not ordered
- LED flashing: Bluetooth connection established

Trigger proof test or function test LED (4)

LED (4) flashing: Proof test or function test currently running.

See "Proof test function" section

Keypad lock LED (5)

- LED lit: Key locked
- LED not lit: Key released

7.3.2 Operation

The device is operated by pressing operating key "E" briefly (< 2 s) or pressing and holding it (> 2 s).

Navigation

- The LED for the selected function flashes
- Press the "E" operating key briefly to switch between the functions
- Press and hold down the "E" operating key to select a particular function

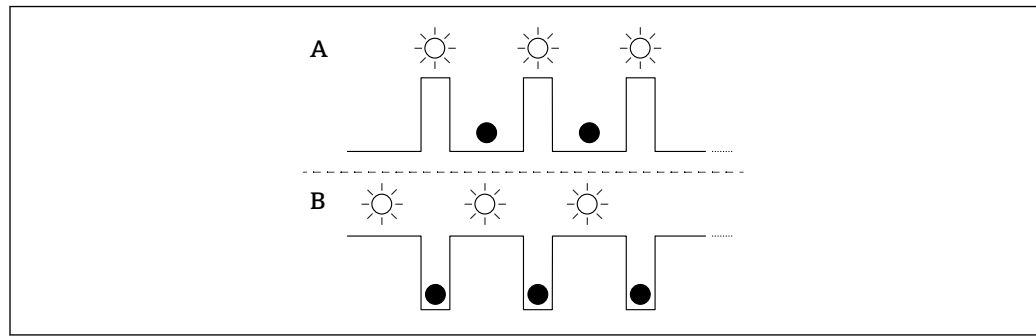
Flashing behavior of LEDs (active/inactive)

A Function selected but not active

B Function selected and active

Disabling the keypad lock

1. Press and hold down operating key "E".
↳ Bluetooth LED flashes.
2. Briefly press operating key "E" repeatedly until the keypad lock LED flashes.
3. Press and hold down operating key "E".
↳ Keypad lock is disabled.

Enabling or disabling Bluetooth

1. If necessary, disable the keypad lock.
2. Repeatedly press the "E" key briefly until the Bluetooth LED flashes.
3. Press and hold down operating key "E".
↳ Bluetooth is enabled (Bluetooth LED is lit) or Bluetooth is disabled (Bluetooth LED goes out).

7.3.3 Proof test function

For proof testing in safety instrumented systems according to WHG

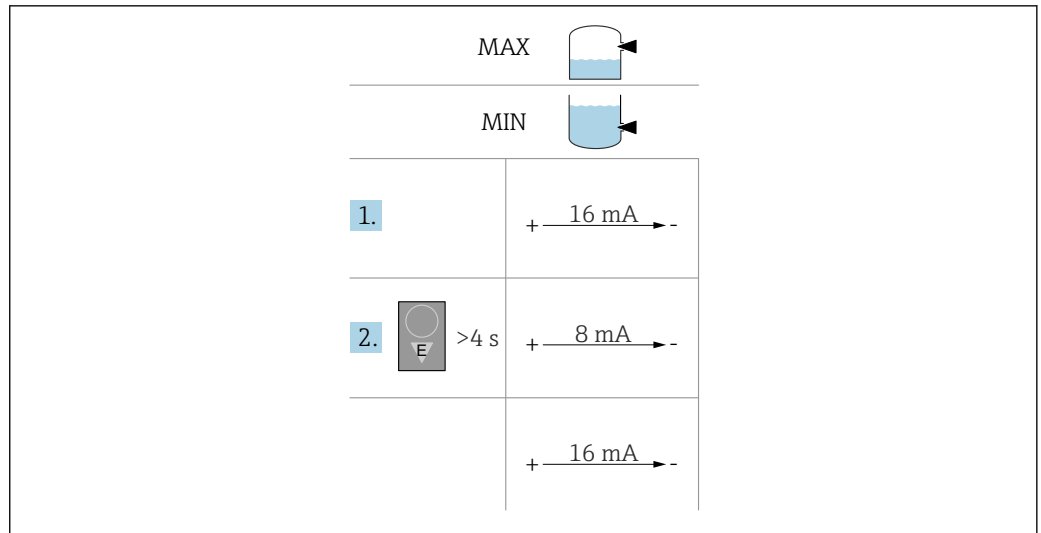

A0054340

1. Make sure that no undesired switching operations are triggered!
 - ↳ The function test must take place when the device condition is OK (16 mA): MAX safety and sensor uncovered or MIN safety and sensor covered. If necessary, disable the keypad lock (see "Disabling the keypad lock" section). Repeatedly press the "E" key briefly until the 'Trigger proof test or function test' LED flashes.
2. Press and hold down operating key "E" for more than 4 s.
 - ↳ The device function check is performed. The output changes from the OK status to the demand state (8 mA). The proof test or function test LED flashes while the function check is ongoing.

The proof test/function test LED is lit continuously for 12 s on successful completion of the function check. The keypad lock LED and Bluetooth LED are off. The device switches back to normal operation.

The 'Trigger proof test/function test' LED flashes quickly for 12 s if the function check is not completed successfully. The keypad lock LED and Bluetooth LED are off. The device remains in normal operation.

Duration of function check: 10 s at least

The function test can also be performed via digital communication interfaces (e.g. HART, DeviceCare, SmartBlue app).

7.4 Access to the operating menu via the operating tool

7.4.1 Connecting the operating tool

Access via the operating tool is possible:

- Via HART communication, e.g. Commubox FXA195
- Via Bluetooth (optional)

FieldCare

Function range

FDT-based plant asset management tool from Endress+Hauser. FieldCare can configure all smart field devices in a system and helps you manage them. By using the status information, FieldCare is also a simple but effective way of checking their status and condition.

Access is via digital communication (Bluetooth, HART communication)

Typical functions:

- Configuration of transmitter parameters
- Loading and saving of device data (upload/download)
- Documentation of the measuring point
- Visualization of the measured value memory (line recorder) and event logbook

 For additional information on FieldCare: See Operating Instructions for FieldCare

DeviceCare

Function range

Tool to connect and configure Endress+Hauser field devices.

Together with the device type managers (DTMs), DeviceCare offers a convenient, comprehensive solution.

 For details, see Innovation Brochure IN01047S

FieldXpert SMT70, SMT77

The Field Xpert SMT70 tablet PC for device configuration enables mobile plant asset management in hazardous (Ex Zone 2) and non-hazardous areas. It is suitable for commissioning and maintenance staff. It manages Endress+Hauser and third-party field instruments with a digital communication interface and documents the progress of the work. The SMT70 is designed as a complete solution. It comes with a pre-installed driver library and is an easy-to-use, touch-enabled tool for managing field devices throughout their entire life cycle.

 Technical Information TI01342S

The Field Xpert SMT77 tablet PC for device configuration enables mobile plant asset management in areas categorized as Ex Zone 1.

 Technical Information TI01418S

7.4.2 Operation via SmartBlue App

The device can be operated and configured with the SmartBlue App.

- The SmartBlue App must be downloaded onto a mobile device for this purpose.
- For information on the compatibility of the SmartBlue App with mobile devices, see **Apple App Store (iOS devices)** or **Google Play Store (Android devices)**.
- Incorrect operation by unauthorized persons is prevented by means of encrypted communication and password encryption.
- The Bluetooth® function can be deactivated after initial device setup.

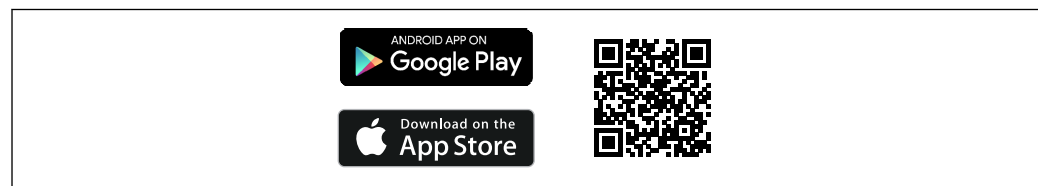

 15 QR code for free Endress+Hauser SmartBlue App



A0033202

Download and installation:

1. Scan the QR code or enter **SmartBlue** in the search field of the Apple App Store (iOS) or Google Play Store (Android).

2. Install and start the SmartBlue App.
3. For Android devices: enable location tracking (GPS) (not required for iOS devices).
4. Select a device that is ready to receive from the device list displayed.

Login:

1. Enter the user name: admin
 2. Enter the initial password: serial number of the device
-  Change the password after logging in for the first time.
 -  Forgotten your password? Contact Endress+Hauser Service.

8 System integration

8.1 Overview of device description files

- Manufacturer ID: 17 (0x0011)
- Device type ID: 0x11DF
- HART specification: 7.6
- DD files, information and files can be found at:
 - www.endress.com
 - www.fieldcommgroup.org

8.2 Measured variables via HART protocol

The following measured values are assigned to the device variables at the factory:

Device variable	Measured value
The Primary variable (PV) (Primary variable) ¹⁾	The Level limit detection option ²⁾
Secondary variable (SV) (Secondary variable)	The Sensor frequency option ³⁾
Tertiary variable (TV) (Third variable)	The Fork state option ⁴⁾
Quaternary variable (QV) (Quaternary variable)	Sensor temperature

- 1) Primary variable (PV) is always applied to the current output.
- 2) **Level limit detection** option is the initial state depending on the fork state (uncovered/covered) and the safety function (MIN/MAX)
- 3) **Sensor frequency** option is the oscillation frequency of the fork
- 4) **Fork state** option describes the fork state (Fork covered/Fork uncovered)

 The assignment of the measured values to the device variables can be changed in the following submenu:
Application → HART output → HART output

 In a HART Multidrop loop, only one device may use the analog current value for signal transmission. For all other devices in the "**Loop current mode**" parameter, select the **Disable** option.

8.2.1 Device variables and measured values

The following codes are assigned to the device variables at the factory:

 The device variables can be queried via HART® command 9 or 33 from a HART® master.

8.2.2 System units

The oscillation frequency is specified in Hz. The temperature can be displayed in °C, °F or K.

9 Commissioning

9.1 Preliminaries



WARNING

Settings on the current output can result in a safety-related condition (e.g., product overflow)!

- ▶ Check current output settings.
- ▶ The setting of the current output depends on the setting in the **Assign PV** parameter.

9.2 Installation and function check

Before commissioning the measuring point, check that the post-installation and post-connection checks have been performed:

-  "Post-mounting check" section
-  "Post-connection check" section

9.3 Overview of commissioning options

- Commissioning via LED indicator operating key
- Commissioning with the SmartBlue app
- Commissioning via FieldCare/DeviceCare/Field Xpert
- Commissioning via additional operating tools (AMS, PDM, etc.)

9.4 Commissioning via FieldCare/DeviceCare

1. Download the DTM: <http://www.endress.com/download> -> Device Driver -> Device Type Manager (DTM)
2. Update the catalog.
3. Click the **Guidance** menu and start the **Commissioning** wizard.

9.4.1 Notes on the "Commissioning" wizard

The **Commissioning** wizard allows you to carry out easy, user-guided commissioning.

1. Once you have started the **Commissioning** wizard, enter the appropriate value in each parameter or select the appropriate option. These values are written directly to the device.
2. Click "Next" to go to the next page.
3. Once all the pages have been completed, click "End" to close the **Commissioning** wizard.

 If the **Commissioning** wizard is cancelled before all necessary parameters have been configured, the device may be in an undefined state. In such situations, it is advisable to reset the device to the factory default settings.

9.4.2 Establishing a connection via FieldCare, DeviceCare and FieldXpert

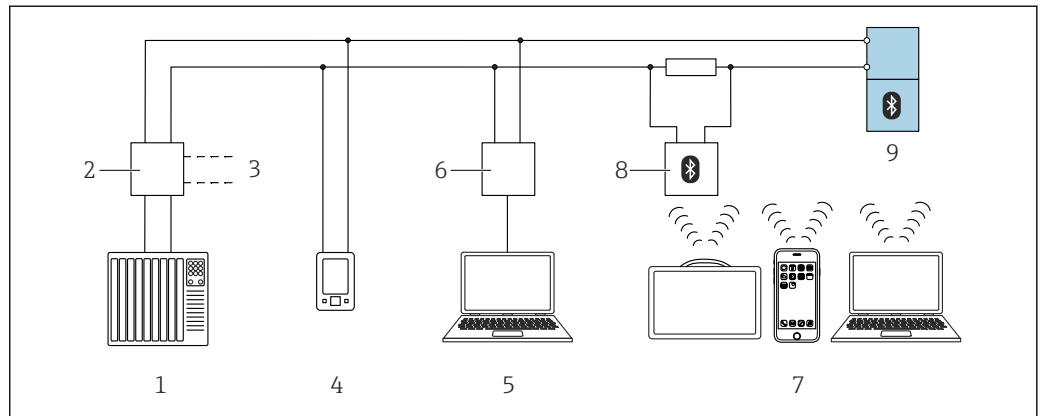

16 Options for remote operation via HART protocol

- 1 PLC (programmable logic controller)
- 2 Transmitter power supply unit, e.g. RN42
- 3 Connection for Commubox FXA195 and AMS Trex™ device communicator
- 4 AMS Trex™ device communicator
- 5 Computer with operating tool (e.g. DeviceCare/FieldCare, AMS Device View, SIMATIC PDM)
- 6 Commubox FXA195 (USB)
- 7 Field Xpert SMT70/SMT77, Smartphone or computer with operating tool (e.g. DeviceCare/FieldCare, AMS Device View, SIMATIC PDM)
- 8 Bluetooth modem with connecting cable (e.g. VIATOR)
- 9 Transmitter

9.5 Commissioning via additional operating tools (AMS, PDM, etc.)

Download the device-specific drivers: <https://www.endress.com/en/downloads>

For more details, see the help for the relevant operating tool.

9.6 Configuring the device address via software

See "HART address" parameter

Enter the address to exchange data via the HART protocol.

- Guidance → Commissioning → HART address
- Application → HART output → Configuration → HART address
- Default HART address: 0

9.7 Simulation

9.7.1 "Simulation" submenu

Process variables and diagnostic events can be simulated with the **Simulation** submenu.

Navigation: Diagnostics → Simulation

During simulation of the switch output or current output, the device issues a warning message for the duration of the simulation.

9.8 Protecting settings from unauthorized access

9.8.1 Software locking or unlocking

Locking via password in FieldCare/DeviceCare/SmartBlue app

Access to parameter configuration of the device can be locked by assigning a password. When the device is delivered from the factory, the user role is set to **Maintenance** option. The device parameters can be fully configured with the **Maintenance** option user role. Afterwards, access to the configuration can be locked by assigning a password. The **Maintenance** option switches to the **Operator** option as a result of this locking. The configuration can be accessed by entering the password.

The password is defined under:

System menu **User management** submenu

The user role is changed from the **Maintenance** option to **Operator** option under:

System → User management

Deactivating the lock via FieldCare/DeviceCare/SmartBlue app

After entering the password, you can enable parameter configuration of the device as an **Operator** option with the password. The user role then changes to **Maintenance** option.

If necessary, the password can be deleted in User management: System → User management

10 Operation

10.1 Reading off the device locking status

10.1.1 LED indicator

Keypad lock LED

-  LED lit: Device is locked
-  LED not lit: Device is unlocked

10.1.2 Operating tool

 Operating tool (FieldCare/DeviceCare/FieldXpert/SmartBlue app)

Navigation: System → Device management → Locking status

10.2 Reading off measured values

The measured values can be read off via the operating tool.

Navigation: **Application** menu → **Measured values** submenu

10.3 Adapting the device to process conditions

The following menus are available for this purpose:

- Basic settings in the **Guidance** menu
- Advanced settings in:
 - **Diagnostics** menu
 - **Application** menu
 - **System** menu



For details, see the "Description of device parameters" documentation.

10.4 Heartbeat Technology (optional)

10.4.1 Heartbeat Verification

"Heartbeat Verification" wizard

This wizard is used to start an automatic verification of the device functionality. The results can be documented as a verification report.

- The wizard can be used via the operating tools
- The wizard guides the user through the entire process for creating the verification report

10.4.2 Heartbeat Verification/Monitoring



The **Heartbeat** submenu is only available during operation via FieldCare, DeviceCare or the SmartBlue app. The submenu contains the wizards that are available with the Heartbeat Verification and Heartbeat Monitoring application packages.



Documentation on the Heartbeat Technology: Endress+Hauser website: www.endress.com → Downloads.

10.4.3 "Medium detection" operating mode



Default setting of operating mode (as-delivered state): point level detection of liquids. This setting covers most applications.

In addition, the following operating modes can be selected in combination with the Heartbeat package:

- Foam detection
- Foam suppression

Foam detection

Area of application: point level detection in liquids with foam generation.

The device detects the foam and switches as soon as the tuning fork is immersed in the foam.



Application in accordance with the WHG (German Water Resources Act) is not possible in this operating mode.

Detection of light foams such as:

- Beer foam
- Milk foam

Influence on switching behavior:

- Particularly large air bubbles in the foam
- Significantly reduced liquid content in the foam
- Change in the properties of the foam during operation

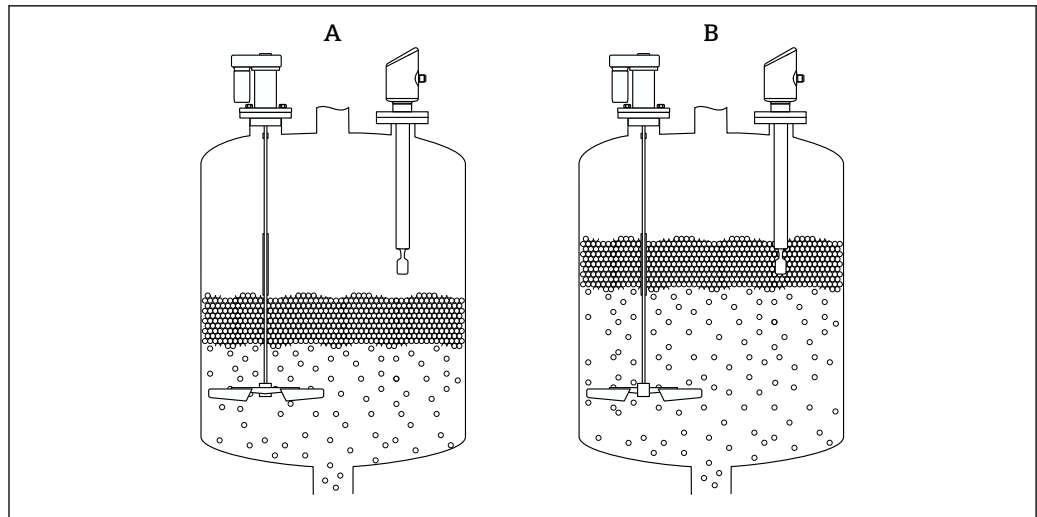

A0054926

17 Operating principle for foam detection

A uncovered
B covered

Foam suppression

Area of application: point level detection in liquids with foam generation.

The device only switches when immersed in a homogeneous liquid.

The device does not react to the foam in this setting (the foam is suppressed).

i Application in accordance with the WHG (German Water Resources Act) is not possible in this operating mode.

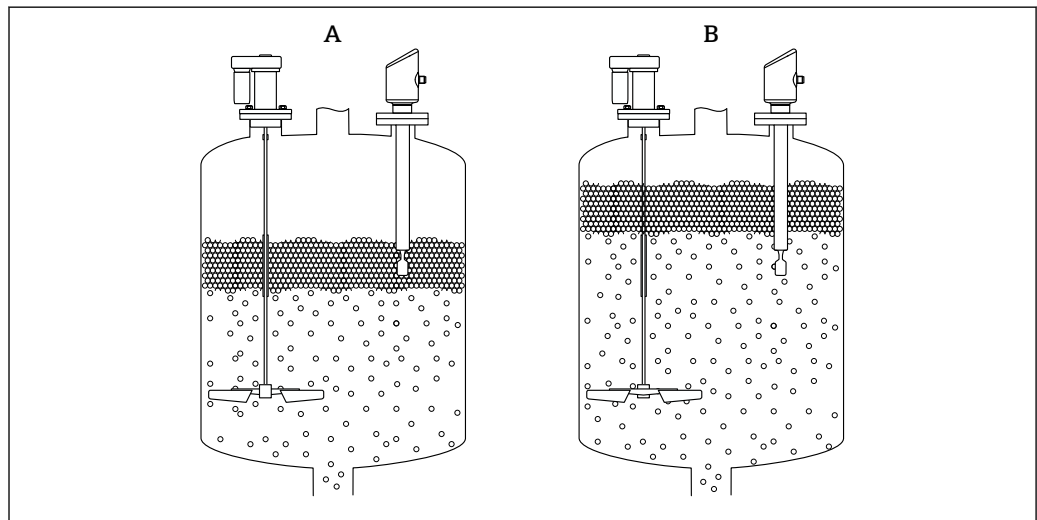

A0054924

18 Operating principle for foam suppression

A uncovered
B covered

10.5 Proof test for WHG devices (optional) ¹⁾

The "Proof test" module contains the **Proof test** wizard required at appropriate intervals for the following applications: WHG (German Water Resources Act):

- The wizard can be used via the operating tools (SmartBlue app, DTM).
- The wizard guides the user through the entire process for creating the verification report.
- The verification report can be saved as a PDF file.

10.6 Displaying the measured value history

 See Special Documentation for SD Heartbeat Technology.

11 Diagnostics and troubleshooting

11.1 General troubleshooting

11.1.1 General errors

Device not starting

- Possible cause: Supply voltage does not match the specification on the nameplate
Remedial action: Apply the correct voltage
- Possible cause: The polarity of the supply voltage is wrong
Remedial action: Correct the polarity
- Possible cause: Load resistance too high
Remedial action: Increase the supply voltage to reach the minimum terminal voltage

LEDs flashing when device is started

Possible cause: Electromagnetic interference influence
Remedial action: Check grounding of the device

HART communication not working

- Possible cause: Communication resistor missing or incorrectly installed
Remedial action: Install the communication resistor (250 Ω) correctly
- Possible cause: Commubox is connected incorrectly
Remedial action: Connect Commubox correctly

11.1.2 Error - SmartBlue operation with Bluetooth®

Operation via SmartBlue is only possible on devices that have a display with Bluetooth (optionally available).

1) Only available for devices with WHG approval

Device is not visible in the live list

- Possible cause: No Bluetooth connection available
Remedial action: Enable Bluetooth in the field device via display or software tool and/or in the smartphone/tablet
- Possible cause: Bluetooth signal outside range
Remedial action: Reduce distance between field device and smartphone/tablet
The connection has a range of up to 25 m (82 ft)
Operating radius with intervisibility 10 m (33 ft)
- Possible cause: Geopositioning is not enabled on Android devices or is not permitted for the SmartBlue app
Remedial action: Enable/permit the geopositioning service on Android device for the SmartBlue app
- Display does not have Bluetooth

Device appears in the live list but a connection cannot be established

- Possible cause: The device is already connected with another smartphone/tablet via Bluetooth
Only one point-to-point connection is permitted
Remedial action: Disconnect the smartphone/tablet from the device
- Possible cause: Incorrect user name and password
Remedial action: The standard user name is "admin" and the password is the device serial number indicated on the device nameplate (only if the password was not changed by the user beforehand)
If the password has been forgotten, contact Endress+Hauser Service (www.addresses.endress.com)

Connection via SmartBlue not possible

- Possible cause: Incorrect password entered
Remedial action: Enter the correct password, paying attention to lower/upper case
- Possible cause: Forgotten password
If the password has been forgotten, contact Endress+Hauser Service (www.addresses.endress.com)

Login via SmartBlue not possible

- Possible cause: Device is being put into operation for the first time
Remedial action: Enter the user name "admin" and the password (device serial number), paying attention to lower/upper case
- Possible cause: The electric current and voltage are not correct.
Remedial action: Increase the supply voltage.

Device cannot be operated via SmartBlue

- Possible cause: Incorrect password entered
Remedial action: Enter the correct password, paying attention to lower/upper case
- Possible cause: Forgotten password
If the password has been forgotten, contact Endress+Hauser Service (www.addresses.endress.com)
- Possible cause: **Operator** option has no authorization
Remedial action: Change to the **Maintenance** option

11.1.3 Measures

For information on measures in the case of an error message: See  "Pending diagnostic messages" section.

If the measures do not rectify the problem, contact your Endress+Hauser office.

11.1.4 Additional tests

If no clear cause of the error can be identified or the source of the problem can be both the device and the application, the following additional tests can be performed:

1. Check that the device concerned is functioning correctly. Replace the device if the digital value does not correspond to the expected value.
2. Switch on simulation and check the current output. Replace the device if the current output does not correspond to the simulated value.
3. Reset the device to the factory setting.

11.1.5 Behavior of the device in the event of a power outage

In the event of an unexpected power outage, the dynamic data are stored permanently (according to NAMUR NE 032).

11.1.6 Behavior of the current output in the event of a failure

The behavior of the current output in the event of failures is defined by the **Failure behavior current output** parameter.

 The device does not have a DIP switch

Parameter overview with brief description

Parameter	Description	Selection / User entry
Failure behavior current output	Defines which current the output assumes in the case of an error. Min: < 3.6 mA Max: >21.5 mA Note: The hardware DIP Switch for alarm current (if available) has priority over software setting.	<ul style="list-style-type: none"> ■ Min. ■ Max.
Failure current	Enter current output value in alarm condition	21.5 to 23 mA

11.2 Diagnostic information on operating status LED

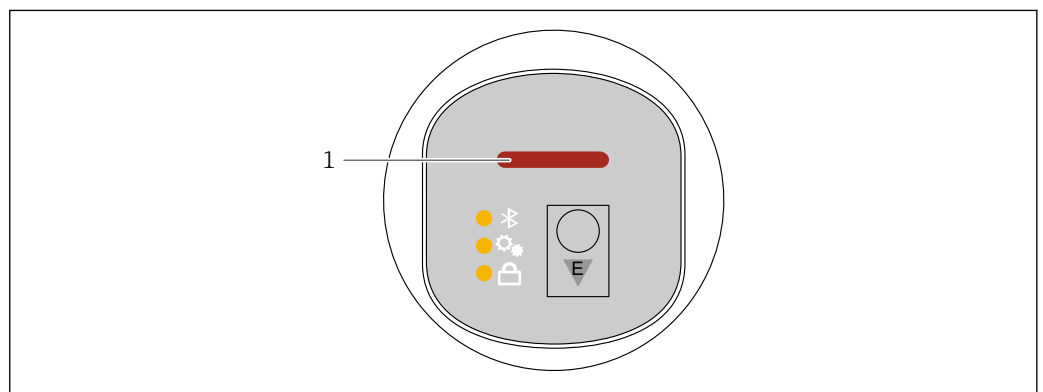

1 Operating status LED

A0052452

- MIN connection, fork uncovered: LED is lit in yellow (8 mA)
MIN connection, fork covered: LED is lit in green (16 mA)
MIN connection, error: LED is lit in red (< 3.6 mA/> 21 mA)
- MAX connection, fork uncovered: LED is lit in green (16 mA)
MAX connection, fork covered: LED is lit in yellow (8 mA)
MAX connection, error: LED is lit in red (< 3.6 mA/> 21 mA)
- When searching for a device (Squawk HART) or device identification or when establishing Bluetooth connection: operating status LED flashes while the function is running
LED flashes independently of the LED color

11.3 Diagnostic event in the operating tool

If a diagnostic event has occurred in the device, the status signal appears in the top left status area of the operating tool together with the corresponding symbol for the event level according to NAMUR NE 107:

- Failure (F)
- Function check (C)
- Out of specification (S)
- Maintenance required (M)

Click the status signal to see the detailed status signal.

The diagnostic events and remedial measures can be printed from the **Diagnostic list** submenu.

11.4 Adapting the diagnostic information

The event level can be configured:

Navigation: Diagnostics → Diagnostic settings → Configuration

11.5 Pending diagnostic messages

Pending diagnostic messages can be displayed in the **Active diagnostics** parameter.

Navigation: Diagnostics → Active diagnostics

11.6 Diagnostic list

All of the diagnostic messages currently pending can be displayed in the **Diagnostic list** submenu.

Navigation: Diagnostics → Diagnostic list

11.6.1 List of diagnostic events

 Electronics replacement or flashing is not possible.

The device must be replaced in these cases.

Diagnostic number	Short text	Remedy instructions	Status signal [from the factory]	Diagnostic behavior [from the factory]
Diagnostic of sensor				
004	Sensor defective	1. Restart device 2. Replace electronics 3. Replace device	F	Alarm

Diagnostic number	Short text	Remedy instructions	Status signal [from the factory]	Diagnostic behavior [from the factory]
007	Sensor defective	1. Check fork 2. Replace device	F	Alarm
042	Sensor corroded	1. Check fork 2. Replace device	F	Alarm
049	Sensor corroded	1. Check fork 2. Replace device	M	Warning ¹⁾
061	Sensor electronics faulty	Replace electronics	F	Alarm
062	Sensor connection faulty	1. Check Main to sensor connection 2. Replace electronics	F	Alarm
081	Sensor initialization faulty	1. Restart device 2. Contact service	F	Alarm
Diagnostic of electronic				
201	Electronics faulty	1. Restart device 2. Replace electronics	F	Alarm
203	HART Device Malfunction	Check device specific diagnosis.	S	Warning
204	HART Electronic Defect	Check device specific diagnosis.	F	Alarm
242	Firmware incompatible	1. Check software 2. Flash or change main electronic module	F	Alarm
252	Module incompatible	1. Check if correct electronic module is plugged 2. Replace electronic module	F	Alarm
263	Electronic incompatible	Check electronic module type	F	Alarm
270	Main electronics defective	Replace main electronics	F	Alarm
272	Main electronics faulty	1. Restart device 2. Contact service	F	Alarm
273	Main electronics defective	Replace main electronics	F	Alarm
282	Data storage inconsistent	Restart device	F	Alarm
283	Memory content inconsistent	1. Restart device 2. Contact service	F	Alarm
287	Memory content inconsistent	1. Restart device 2. Contact service	M	Warning
388	Electronics and HistoROM defective	1. Restart device 2. Replace electronics and HistoROM 3. Contact service	F	Alarm
Diagnostic of configuration				
410	Data transfer failed	1. Retry data transfer 2. Check connection	F	Alarm
412	Processing download	Download active, please wait	C	Warning
420	HART Device Configuration Locked	Check device locking configuration.	S	Warning
421	HART Loop Current fixed	Check Multi-drop mode or current simulation.	S	Warning
431	Trim required	Carry out trim	C	Warning

Diagnostic number	Short text	Remedy instructions	Status signal [from the factory]	Diagnostic behavior [from the factory]
437	Configuration incompatible	1. Update firmware 2. Execute factory reset	F	Alarm
438	Dataset different	1. Check dataset file 2. Check device parameterization 3. Download new device parameterization	M	Warning
441	Current output 1 saturated	1. Check process 2. Check current output settings	S	Warning
484	Failure mode simulation active	Deactivate simulation	C	Alarm
485	Process variable simulation active	Deactivate simulation	C	Warning
491	Current output simulation active	Deactivate simulation	C	Warning
495	Diagnostic event simulation active	Deactivate simulation	S	Warning
538	Configuration Sensor Unit invalid	1. Check sensor configuration 2. Check device configuration	M	Warning
Diagnostic of process				
801	Supply voltage too low	Increase supply voltage	F	Alarm
802	Supply voltage too high	Decrease supply voltage	S	Warning
805	Loop current faulty	1. Check wiring 2. Replace electronics	F	Alarm
806	Loop diagnostics	1. Check supply voltage 2. Check wiring and terminals	M	Warning ¹⁾
807	No Baseline due to insuf. volt. at 20 mA	Increase supply voltage	M	Warning
825	Electronics temperature	1. Check ambient temperature 2. Check process temperature	S	Warning
826	Sensor temperature out of range	1. Check ambient temperature 2. Check process temperature	S	Warning ¹⁾
842	Process limit	1. Check process density 2. Check fork	F	Alarm
846	HART Non-Primary Variable Out of Limit	Check device specific diagnosis.	S	Warning
847	HART Primary Variable Out of Limit	Check device specific diagnosis.	S	Warning
848	HART Device Variable Alert	Check device specific diagnosis.	S	Warning
900	Process alert frequency too low	Check process conditions	M	Warning ¹⁾
901	Supply voltage too low	Increase supply voltage	C	Warning

1) Diagnostic behavior can be changed.

11.7 Event logbook

11.7.1 Event history

The **"Event logbook"** submenu provides a chronological overview of the event messages that have occurred ²⁾.

Navigation: Diagnostics → Event logbook

A maximum of 100 event messages can be displayed in chronological order.

The event history includes entries for:

- Diagnostic events
- Information events

In addition to the operating time when the event occurred, each event is also assigned a symbol that indicates whether the event has occurred or is finished:

- Diagnostic event
 - ☹: Occurrence of the event
 - ☺: End of the event
- Information event
 - ☹: Occurrence of the event

11.7.2 Filtering the event logbook

Filters can be used to determine which category of event messages is displayed in the **Event logbook** submenu.

Navigation: Diagnostics → Event logbook

Filter categories

- All
- Failure (F)
- Function check (C)
- Out of specification (S)
- Maintenance required (M)
- Information

11.7.3 Overview of information events

 I11284 and I11285 cannot occur
The device has no DIP switches

Info number	Info name
I1000	----- (Device ok)
I1089	Power on
I1090	Configuration reset
I1091	Configuration changed
I11074	Device verification active
I1110	Write protection switch changed
I11104	Loop diagnostics
I11284	DIP MIN setting to HW active
I11285	DIP SW setting active

2) If the device is operated via FieldCare, the events list can be displayed using the FieldCare function "Event List".

Info number	Info name
I1151	History reset
I1154	Reset terminal voltage min/max
I1155	Reset electronics temperature
I1157	Memory error event list
I1256	Display: access status changed
I1264	Safety sequence aborted
I1335	Firmware changed
I1397	Fieldbus: access status changed
I1398	CDI: access status changed
I1440	Main electronic module changed
I1444	Device verification passed
I1445	Device verification failed
I1461	Sensor verification failed
I1512	Download started
I1513	Download finished
I1514	Upload started
I1515	Upload finished
I1551	Assignment error fixed
I1552	Failed: Main electronic verification
I1554	Safety sequence started
I1555	Safety sequence confirmed
I1556	Safety mode off
I1956	Reset

11.8 Resetting the device

11.8.1 Reset via digital communication

The device can be reset with the **Device reset** parameter.

Navigation: System → Device management

 Any customer-specific configuration carried out at the factory is not affected by a reset (customer-specific configuration remains).

11.8.2 Resetting the password via the operating tool

Enter a code to reset the current 'Maintenance' password.
The code is delivered by your local support.

Navigation: System → User management → Reset password → Reset password

 For details see the "Description of device parameters" documentation.

11.9 Device information

All device information is contained in the **Information** submenu.

Navigation: System → Information

 For details see the "Description of device parameters" documentation.

11.10 Firmware history

11.10.1 Version

01.00.00

Initial software

12 Maintenance

12.1 Maintenance work

12.1.1 Exterior cleaning

The cleaning agents used should not corrode the surface and the seals.

The following cleaning agents can be used:

- Ecolab P3 topaktive 200
- Ecolab P3 topaktive 500
- Ecolab P3 topaktive OKTO
- Ecolab P3 topax 66
- Ecolab TOPAZ AC5
- 30 % H₂O₂ solution (vaporisation)

Observe the degree of protection of the device.

13 Repair

13.1 General information

13.1.1 Repair concept

The Endress+Hauser repair concept is devised in such a way that repairs can only be carried out through device replacement.

13.1.2 Replacing a device

After the device is replaced, previously saved parameters can be copied to the newly installed device.

After an entire device has been replaced, the parameters can be downloaded to the device again via the communication interface. The data must have been uploaded to the PC beforehand using the "FieldCare/DeviceCare" software.

13.2 Return

The requirements for safe device return can vary depending on the device type and national legislation.

1. Refer to the web page for information:
<https://www.endress.com/support/return-material>
↳ Select the region.

2. If returning the device, pack the device in such a way that it is reliably protected against impact and external influences. The original packaging offers the best protection.

13.3 Disposal



If required by the Directive 2012/19/EU on waste electrical and electronic equipment (WEEE), the product is marked with the depicted symbol in order to minimize the disposal of WEEE as unsorted municipal waste. Do not dispose of products bearing this marking as unsorted municipal waste. Instead, return them to the manufacturer for disposal under the applicable conditions.

14 Accessories

Accessories currently available for the product can be selected via the Product Configurator at www.endress.com:

1. Select the product using the filters and search field.
2. Open the product page.
3. Select **Spare parts & Accessories**.

14.1 Device-specific accessories

14.1.1 M12 socket

M12 socket, straight

- Material:
Body: PA; union nut: stainless steel; seal: EPDM
- Degree of protection (fully locked): IP69
- Order number: 71638191

M12 socket, elbowed

- Material:
Body: PA; union nut: stainless steel; seal: EPDM
- Degree of protection (fully locked): IP69
- Order number: 71638253

14.1.2 Cables

Cable 4 x 0.34 mm² (20 AWG) with M12 socket, elbowed, screw plug, length 5 m (16 ft)

- Material: body: TPU; union nut: nickel-plated die-cast zinc; cable: PVC
- Degree of protection (fully locked): IP68/69
- Order number: 52010285
- Wire colors
 - 1 = BN = brown
 - 2 = WT = white
 - 3 = BU = blue
 - 4 = BK = black

14.1.3 Welding neck, process adapter and flange

 For details, refer to TI00426F/00/EN "Weld-in adapters, process adapters and flanges".

14.2 DeviceCare SFE100

Configuration tool for IO-Link, HART, PROFIBUS and FOUNDATION Fieldbusfield devices
DeviceCare is available for download free of charge at www.software-products.endress.com. You need to register in the Endress+Hauser software portal to download the application.

 Technical Information TI01134S

14.3 FieldCare SFE500

FDT-based plant asset management tool

It can configure all intelligent field units in your system and helps you manage them. By using the status information, it is also a simple but effective way of checking their status and condition.

 Technical Information TI00028S

14.4 Device Viewer

All the spare parts for the device, along with the order code, are listed in the *Device Viewer* (www.endress.com/deviceviewer).

14.5 Field Xpert SMT70

Universal, high-performance tablet PC for device configuration in Ex Zone 2 and non-Ex areas

 For details, see "Technical Information" TI01342S

14.6 Field Xpert SMT77

Universal, high-performance tablet PC for device configuration in Ex Zone 1 areas

 For details, see "Technical Information" TI01418S

14.7 SmartBlue app

Mobile app for easy configuration of devices on site via Bluetooth wireless technology

15 Technical data

15.1 Output

15.1.1 Output signal

SIO

8/16 mA (SIO) with superimposed digital communication protocol HART, 2-wire

Continuous operation

4 to 20 mA proportional to the oscillation frequency with superimposed digital communication protocol HART, 2-wire

The current output offers a choice of three different operating modes:

- 4.0 to 20.5 mA
- NAMUR NE 43: 3.8 to 20.5 mA (factory setting)
- US mode: 3.9 to 20.5 mA

15.1.2 Signal on alarm for devices with current output

Current output

Signal on alarm in accordance with NAMUR recommendation NE 43.

- Max. alarm: can be set from 21.5 to 23 mA
- Min. alarm: < 3.6 mA (factory setting)

15.1.3 Load

In order to guarantee sufficient terminal voltage, a maximum load resistance R_L (including line resistance) must not be exceeded, depending on the supply voltage U of the supply unit.

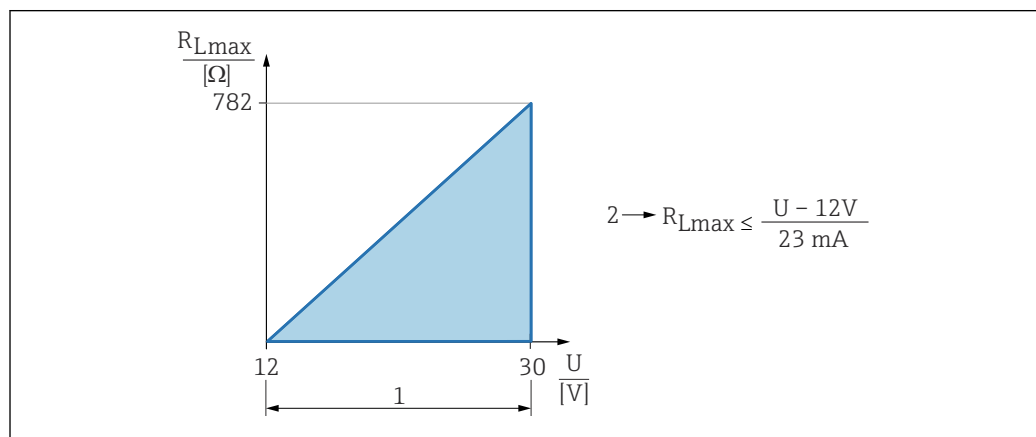

A0052602

- 1 Power supply 12 to 30 V
 2 R_{Lmax} maximum load resistance
 U Supply voltage

 Operation via handheld terminal or PC with operating program: take minimum communication resistance of 250 Ω into consideration.

15.1.4 Damping

A damping affects all continuous outputs. Damping can be enabled as follows:

- Via Bluetooth, handheld terminal or PC with operating program, continuous from 0 to 999 s, in steps of 0.1 s
- Factory setting: 1 s (can be configured from 0 to 999 s)

15.1.5 Ex connection data

 See the separate technical documentation (Safety Instructions (XA)) on www.endress.com/download.

15.1.6 Protocol-specific data

Manufacturer ID:

17(0x0011)

Device type ID:

0x11DF

Device revision:

1

HART specification:

7.6

DD version:

1

Device description files (DTM, DD)

Information and files available at:

- www.endress.com
On the product page for the device: Documents/Software → Device drivers
- www.fieldcommgroup.org

HART load:

Min. 250 Ω

The following measured values are assigned to the device variables at the factory:

Device variable	Measured value
Primary variable (PV) ¹⁾	Level limit detection ²⁾
Secondary variable (SV)	Sensor frequency ³⁾
Tertiary variable (TV)	Fork state ⁴⁾
Quaternary variable (QV)	Sensor temperature

- 1) The PV is always applied to the current output.
- 2) Level limit detection is the initial state depending on the fork state (uncovered/covered) and the safety function (MIN/MAX)
- 3) Sensor frequency is the oscillation frequency of the fork
- 4) Fork state describes the fork state (Fork covered/Fork uncovered)

Choice of HART device variables

- Level limit detection
- Sensor frequency
- Fork state
- Sensor temperature
- Electronics temperature

- Measured current³⁾
- Terminal voltage³⁾
- Not used

15.2 Environment

15.2.1 Ambient temperature range

-40 to +85 °C (-40 to +185 °F)

The permitted ambient temperature is reduced at higher process temperatures.

i The following information only takes functional aspects into consideration. Additional restrictions may apply for certified device versions.

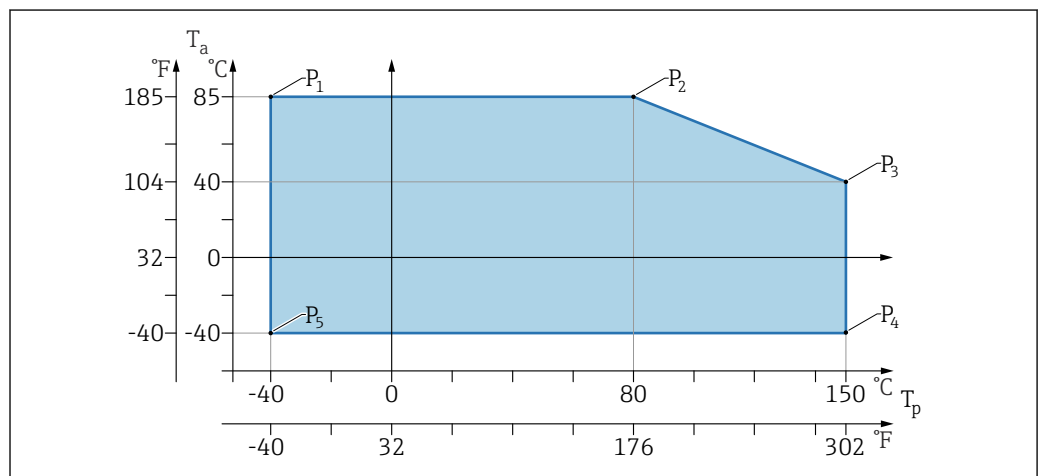

19 Ambient temperature T_a depending on the process temperature T_p

P	T_p	T_a
P1	-40 °C (-40 °F)	+85 °C (+185 °F)
P2	+80 °C (+176 °F)	+85 °C (+185 °F)
P3	+150 °C (+302 °F)	+40 °C (+77 °F)
P4	+150 °C (+302 °F)	-40 °C (-40 °F)
P5	-40 °C (-40 °F)	-40 °C (-40 °F)

15.2.2 Storage temperature

-40 to +85 °C (-40 to +185 °F)

15.2.3 Operating height

Up to 5 000 m (16 404 ft) above sea level

15.2.4 Climate class

According to IEC 60068-2-38 test Z/AD (relative humidity 4 to 100 %).

3) Visible depending on the order options or device settings

15.2.5 Degree of protection

Test as per IEC 60529 Edition 2.2 2013-08/ DIN EN 60529:2014-09 DIN EN 60529:2014-09 and NEMA 250-2014

For mounted M12 connecting cable: IP66/68/69, NEMA type 4X/6P
/IP68,: (1.83 mH₂O for 24 h))

15.2.6 Pollution degree

Pollution degree 2 according to IEC/EN 61010-1

15.2.7 Vibration resistance

- Stochastic noise (random sweep) as per DIN EN 60068-2-64 Case 2/
IEC 60068-2-64 Case 2
- Guaranteed for 5 to 2 000 Hz: 1.25 (m/s²)²/Hz, ~ 5 g

15.2.8 Shock resistance

- Test standard: DIN EN 60068-2-27 Case 2
- Shock resistance: 30 g (18 ms) in all 3 axes

15.2.9 Electromagnetic compatibility (EMC)

- Electromagnetic compatibility as per EN 61326 series and NAMUR recommendation
EMC (NE21)
- Maximum deviation under the effect of disturbance: < 0.5%

For more details refer to the EU Declaration of Conformity.

Index

A

Access authorization to parameters	
Read access	20
Write access	20
Access code	20
Incorrect input	20

C

CE mark	8
Cleaning	39

D

Declaration of Conformity	8
Device locking, status	28
Device replacement	39
DeviceCare	24
Diagnostic event	
In the operating tool	34
Diagnostic events	33
Diagnostic list	34
Display values	
For locking status	28
Disposal	40
Document	
Function	5
Document function	5

E

Event history	37
Events list	37
Exterior cleaning	39

F

Field of application	
Residual risks	7
FieldCare	23
Function	23
Filtering the event logbook	37
FV (HART variable)	25

H

HART variables	25
--------------------------	----

I

Intended use	7
------------------------	---

M

Mounting requirements	
Switch point	12

N

Nameplate	10
---------------------	----

O

Operational safety	8
------------------------------	---

P

Post-connection check	19
Product security	8
PV (HART variable)	25

R

Read access	20
Reading off measured values	28
Repair concept	39
Replacing a device	39
Requirements for personnel	7
Return	39

S

Settings	
Adapting the device to process conditions	29
Submenu	
Events list	37
SV (HART variable)	25

T

Troubleshooting	31
TV (HART variable)	25

U

Use of measuring devices	
Borderline cases	7
Incorrect use	7
Use of the device	
see Intended use	

W

Workplace safety	7
Write access	20



71646083

www.addresses.endress.com
