

Brief Operating Instructions

NAR300 system

Oil leak detector float sensor



These Instructions are Brief Operating Instructions; they are not a substitute for the Operating Instructions pertaining to the device.

Detailed information about the device can be found in the Operating Instructions and the other documentation:

Available for all device versions via:

- Internet: www.endress.com/deviceviewer
- Smart phone/tablet: *Endress+Hauser Operations App*



A0023555

Table of contents

1	Document information	4
1.1	Symbols used	4
1.2	Documentation	6
2	Safety-related basic instructions	7
2.1	Basic safety instructions	7
2.2	Intended use	7
2.3	Workplace safety	7
2.4	Operational safety	7
2.5	Product safety	8
3	Product description	9
3.1	Product design	9
4	Incoming acceptance and product identification	10
4.1	Incoming acceptance	10
4.2	Product identification	10
4.3	Manufacturer address	16
4.4	Storage and transport	17
5	Installation	18
5.1	Mounting NAR300 system	18
5.2	Adjustment	26
6	Electrical connection	28
6.1	NRR261-4/A/B/C wiring	28
6.2	NRR262-4/A/B/C wiring	30
6.3	NRR261-5 wiring	32
6.4	Wiring diagram	34
6.5	Alarm activation principle	36

1 Document information

1.1 Symbols used

1.1.1 Safety symbols

DANGER

This symbol alerts you to a dangerous situation. Failure to avoid this situation will result in serious or fatal injury.

WARNING

This symbol alerts you to a dangerous situation. Failure to avoid this situation can result in serious or fatal injury.

CAUTION

This symbol alerts you to a dangerous situation. Failure to avoid this situation can result in minor or medium injury.

NOTICE

This symbol contains information on procedures and other facts which do not result in personal injury.

1.1.2 Electrical symbols



Alternating current



Direct current and alternating current



Direct current



Ground connection

A grounded terminal which, as far as the operator is concerned, is grounded via a grounding system.

Protective earth (PE)

Ground terminals that must be connected to ground prior to establishing any other connections.

The ground terminals are located on the interior and exterior of the device:

- Interior ground terminal: protective earth is connected to the mains supply.
- Exterior ground terminal: device is connected to the plant grounding system.

1.1.3 Tool symbols



Phillips head screwdriver



Flat blade screwdriver



Torx screwdriver



Allen key



Open-ended wrench

1.1.4 Symbols for certain types of information and graphics

Permitted

Procedures, processes or actions that are permitted

Preferred

Procedures, processes or actions that are preferred

Forbidden

Procedures, processes or actions that are forbidden

Tip

Indicates additional information



Reference to documentation



Reference to graphic



Notice or individual step to be observed

1, 2, 3

Series of steps



Result of a step



Visual inspection



Operation via operating tool



Write-protected parameter

1, 2, 3, ...

Item numbers

A, B, C, ...

Views

→ **Safety instructions**

Observe the safety instructions contained in the associated Operating Instructions



Temperature resistance of the connection cables

Specifies the minimum value of the temperature resistance of the connection cables

1.2 Documentation

The following documentation types are available in the Downloads area of the Endress +Hauser website (www.endress.com/downloads).



For an overview of the scope of the associated Technical Documentation, refer to the following:

W@M Device Viewer (www.endress.com/deviceviewer): Enter the serial number on the nameplate.

1.2.1 Technical Information (TI)

Planning aid

The document contains all the technical data on the device and provides an overview of the accessories and other products that can be ordered for the device.

1.2.2 Brief Operating Instructions (KA)

Guide that takes you quickly to the first measured value

The Brief Operating Instructions contain all the essential information from incoming acceptance to initial commissioning.

1.2.3 Operating Instructions (BA)

The Operating Instructions contain all the information that is required in various phases of the life cycle of the device: from product identification, incoming acceptance, and storage, to mounting, connection, operation, and commissioning, through to troubleshooting, maintenance, and disposal.

1.2.4 Safety Instructions (XA)

Depending on the approval, the following Safety Instructions (XA) are supplied with the device. They are an integral part of the Operating Instructions.



The nameplate indicates the Safety Instructions (XA) that are relevant to the device.

2 Safety-related basic instructions

2.1 Basic safety instructions

2.1.1 Requirements for the personnel

The personnel must fulfill the following requirements for its tasks:

- ▶ Trained, qualified specialists must have a relevant qualification for this specific function and task.
- ▶ Are authorized by the plant owner/operator.
- ▶ Are familiar with federal/national regulations.
- ▶ Before starting work, read and understand the instructions in the manual and supplementary documentation as well as the certificates (depending on the application).
- ▶ Follow instructions and comply with basic conditions.

2.2 Intended use

Applications and measured materials

Equipment intended for use in hazardous locations, sanitary applications, or high-risk applications due to process pressure have the corresponding label attached to their nameplates.

To ensure that the device remains in proper condition for the operation time:

- ▶ Only use the device in full compliance with the data on the nameplate and the general conditions listed in the Operating Instructions and supplementary documentation.
- ▶ Check the nameplate to ensure that the ordered equipment has the correct specifications for the certification-related area (example: explosion proof, safety of pressure vessels).
- ▶ If the device is not operated at an atmospheric temperature, compliance with the relevant basic conditions specified in the relevant device documentation is absolutely essential.
- ▶ Provide permanent protection for the equipment against corrosion caused by environmental effects.
- ▶ Do not exceed the limit values in "Technical Information."

The manufacturer is not liable for damage caused by improper or non-designated use.

2.3 Workplace safety

For work on and with the device:

- ▶ Wear the required personal protective equipment according to local/national regulations.

2.4 Operational safety

Risk of injury!

- ▶ Operate the device only if it is in proper technical condition, free from errors and faults.
- ▶ The operator is responsible for interference-free operation of the device.

Hazardous area

To eliminate danger to persons or the facility when the device is used in the hazardous area (e.g. explosion protection):

- ▶ Check the nameplate to verify if the device ordered can be put to its intended use in the hazardous area.
- ▶ Observe the specifications in the separate supplementary documentation that is an integral part of these instructions.

2.5 Product safety

This device was designed in accordance with GEP (Good Engineering Practice) to meet state-of-the-art safety requirements, has been tested, and left the factory in a condition in which it is safe to operate. It meets the general safety standards and legal requirements.

2.5.1 CE mark

This measuring system meets the legal requirements of the applicable EU Directive. These are listed in the corresponding EU Declaration of Conformity along with the standards applied.

Endress+Hauser affixes the CE mark to this equipment as a sign of guarantee that this equipment has successfully passed testing.

3 Product description

NAR300 system is designed to be installed in a pit within an oil retaining dike, a plant, or a sump pit near a pump yard, where it can provide the ultimate in leak detection function for oils, such as petrochemicals and vegetable oils. The system utilizes two different detection principles, conductivity and tuning fork, to monitor detection status individually. With a two-stage alarm logic process, it has an extremely low false alarm rate, and this ensures the safety of the tank yard with an accurate yet simple device configuration.

NOTICE

TIIS specifications

These operating instructions are not intended for products with TIIS specifications.

- ▶ If you are using a product with TIIS specifications, download and refer to KA01577G/33/JA/01.22-00 or an earlier version from our website (www.endress.com/downloads).

3.1 Product design

NAR300 system is configured in combination with mainly the following products.

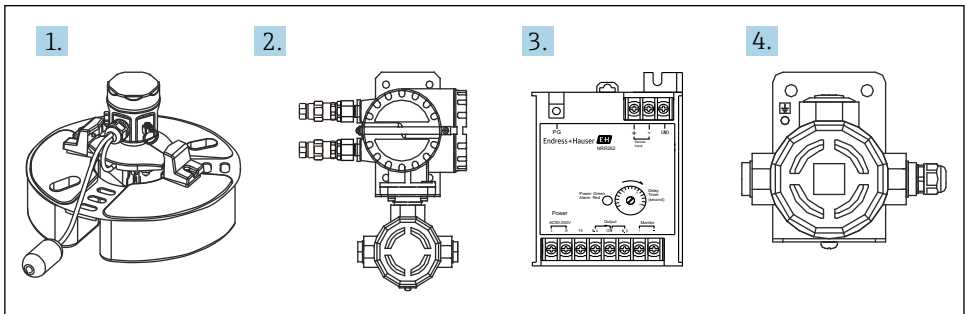

A0047557

1 Product design

- 1 Float sensor NAR300
- 2 Ex d [ia] converter NRR261
- 3 Ex [ia] converter NRR262
- 4 Ex [ia] sensor I/F Ex box

4 Incoming acceptance and product identification

4.1 Incoming acceptance

Upon receipt of the goods, check the following:

- Are the order codes on the delivery note and the product label identical?
- Are the goods undamaged?
- Do the nameplate data match the ordering information on the delivery note?
- If required (see nameplate): Are the Safety Instructions (XA) enclosed?



If one or more of these conditions are not satisfied, contact your Endress+Hauser Sales Center or distributor.

4.2 Product identification

The following options are available for identification of the device:

- Nameplate specifications
- Extended order code on the delivery note (including details of the device specification codes)
- Entering the serial number from the nameplate in *W@M Device Viewer* (www.endress.com/deviceviewer) will display all the information about the device.



Note that the information on a nameplate may be changed without notice when credentials and certificates are updated.

4.2.1 Nameplate specifications

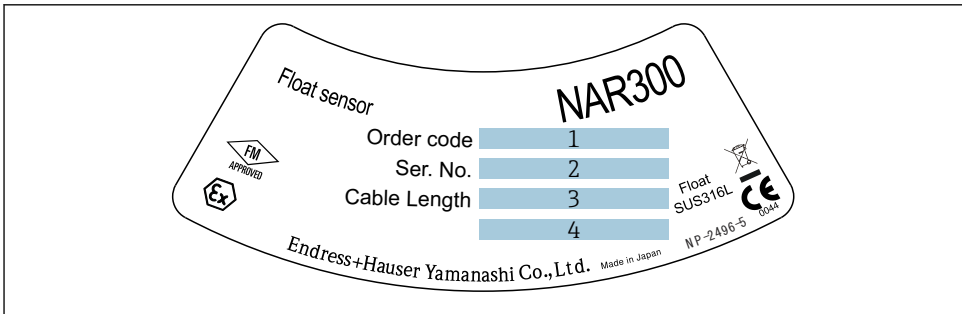

A0038619

2 NAR300 model nameplate

- 1 Order code
- 2 Serial number
- 3 Cable length (order code 040)
- 4 Explosion-proof performance

<p>A</p> <div style="border: 1px solid black; padding: 5px;"> <p>Endress+Hauser </p> <p>Order code 1</p> <p>Ser. no. 2</p> <p> S. Cl. I, Div. 1, Gr. C, D, T4 Cl. I, Zone 1 [0] AEx ia[ia] IIB T4</p> <p>APPROVED</p> <p>Intrinsic safety circuit (Power) U_i=28V I_i=93mA P_i=0,65W L_i=48 μH C_i=0</p> <p>Intrinsic safety circuit 2: U_o=13V I_o=46,8mA P_o=152,1mW L_o=58,3mH C_o=0,25 μF</p> <p>Ambient Temp. : -20~+60°C</p> <p>Process Temp. : -20~+60°C </p> <p>Endress+Hauser Yamanashi Co.,Ltd. Yamamashi 406-0846 Made in Japan NP-2668</p> </div> <div style="border: 1px solid black; padding: 5px; margin-top: 5px;"> <p>Caution :</p> <ul style="list-style-type: none"> ▪ Do not modify parts and circuits of this instrument. ▪ Use the cables which thermal endurance is over 70°C. ▪ Refer to control drawing Ex1087-1281- * IP67 Type 4X <p>Endress+Hauser Yamanashi Co.,Ltd. Yamamashi 406-0846 Made in Japan NP-2742</p> </div>	<p>B</p> <div style="border: 1px solid black; padding: 5px;"> <p>Endress+Hauser </p> <p style="text-align: right;">NAR300</p> <p>Order code 1</p> <p>Ser. no. 2</p> <p> II 1/2G Ex ia[ia] Gaj IIB T4 Gb FM 14ATEX0048X</p> <p>Ex ia[ia] Gaj IIB T4 Gb IECEX FMG 14,0024X</p> <p>Intrinsic safety circuit (Power) U_i=28V I_i=93mA P_i=0,65W L_i=48μH C_i=0</p> <p>Intrinsic safety circuit 2: U_o=13V I_o=46,8mA P_o=152,1mW L_o=58,3mH C_o=0,25μF</p> <p>Ambient Temp. : -20~+60°C</p> <p>Process Temp. : -20~+60°C </p> <p>Endress+Hauser Yamanashi Co.,Ltd. Yamamashi 406-0846 Made in Japan NP-2678-1</p> </div> <div style="border: 1px solid black; padding: 5px; margin-top: 5px;"> <p>Caution :</p> <ul style="list-style-type: none"> ▪ Do not modify parts and circuits of this instrument. ▪ Use the cables which thermal endurance is over 70°C. ▪ Refer to instruction manual IP67 XA01741G-A/08/EN <p>Endress+Hauser Yamanashi Co.,Ltd. Yamamashi 406-0846 Made in Japan NP-2743-1</p> </div>
---	---

A0039861

3 Nameplate for NAR300

- A NAR300 nameplate for FM
- B NAR300 nameplate for ATEX / IECEX
- 1 Order code
- 2 Serial number

A



Endress+Hauser 
NRR261

Order Code
Seri. no.

 XP-AIS Class I, Div. 1,2, Gp. C, D, T4
Class I, Zone 1[0], AEx db ia[ja] IIB T4
Ambient temperature: -20°C ~ +60°C

Non Intrinsically safe circuit:
Power supply :
Um : AC 250 V 50/60 Hz, DC 250 V
Contact output : 5 A 250 V AC, 5 A 30 V DC
Manufacturing date:
Conduit entry of the main body: M26 x 1.5

Caution: A seal shall be installed within 18 inches of the enclosure.
: Do not modify internal parts or circuits.
: Use supply wires suitable 70°C minimum.
: Do not open the cover when energized.
: Refer to control drawing XA1745G-*/08/EN.

 0044

Endress+Hauser Yamanashi Co., Ltd
Yamanashi 406-0846 Made in Japan NP-2745-1



B



Endress+Hauser 
NRR261

Order Code
Seri. no.

 ATEX: II 1/2G Ex db ia[ja Ga] IIB T4 Gb
FM 14ATEX0048X
IECEX: Ex db ia [ja Ga] IIB T4 Gb
IECEX FMG 14.0024X
Ambient temperature: -20°C ~ +60°C NEMA 4X, IP67

Non Intrinsically safe circuit:
Power supply :
Um : AC 250 V 50/60 Hz, DC 250 V
Contact output : 5 A 250 V AC, 5 A 30 V DC
Manufacturing date:
Conduit entry of the main body: M26 x 1.5

Caution: Do not modify internal parts or circuits.
: Use supply wires suitable 70°C minimum.
: Do not open the cover when energized.   
: Refer to Ex instruction manual XA01742G-*/08/EN

 0044

Endress+Hauser Yamanashi Co., Ltd
Yamanashi 406-0846 Made in Japan NP-2744-1

A0039862

 4 Nameplate for NRR261

- A NRR261 nameplate for FM (NAR300 integrated type)
- B NRR261 nameplate for ATEX / IECEX (NAR300 integrated type)
- 1 Order code

- 2 *Serial number*
- 3 *Power supply voltage*
- 4 *Manufacturing date*

A

Endress+Hauser 

NRR262

Order code 1



Seri. no. 2

 **FM** APPROVED AIS Class I, Div. 1, Gp. C, D
 Class I, Zone 0, AEx [ia] IIB
 Ambient temperature: -20°C ~ + 60°C IP20

Intrinsically safe circuit:
 $U_o = 28\text{ V}$ $I_o = 85\text{ mA}$ $P_o = 595\text{ mW}$ $C_o = 0.083\ \mu\text{F}$ $L_o = 2.4\text{mH}$

non Intrinsically safe circuit :
 Power supply : 3
 U_m : AC 250 V 50/60 Hz, DC 250 V
 Contact output : 5 A 250 V AC, 5 A 30 V DC

Manufacturing date: 4 

Caution: • NRR262 must be installed in non-hazardous area.
 • Do not modify internal parts or circuits
 • Refer to control drawing XA01746G-*/08/EN.  

Endress + Hauser Yamanashi Co., Ltd
 Yamanashi 406-0846 NP-2741-1
 Made in Japan

B

Endress+Hauser 

NRR262

Order code 1



Seri. no. 2

 ATEX: II 2G [Ex ia] IIB Gb
 FM 14ATEX0048X
 IECEx: [Ex ia] IIB Gb
 IECEx FMG 14.0024X
 Ambient temperature: -20°C ~ + 60°C IP20

Intrinsically safe circuit:
 $U_o = 28\text{ V}$ $I_o = 85\text{ mA}$ $P_o = 595\text{ mW}$ $C_o = 0.083\ \mu\text{F}$ $L_o = 2.4\text{mH}$

non Intrinsically safe circuit :
 Power supply : 3
 U_m : AC 250 V 50/60 Hz, DC 250 V
 Contact output : 5 A 250 V AC, 5 A 30 V DC

Manufacturing date: 4 



Caution: • NRR262 must be installed in non-hazardous area.
 • Do not modify internal parts or circuits
 • Refer to Ex-instruction manual XA01743-*/08/EN.  

Endress + Hauser Yamanashi Co., Ltd
 Yamanashi 406-0846 NP-2740-1
 Made in Japan

A0039864

 5 Nameplate for NRR262



- A NRR262 nameplate for FM
- B NRR262 nameplate for ATEX / IECEx
- 1 Order code
- 2 Serial number
- 3 Power supply voltage
- 4 Manufacturing date

A	B	C
Endress+Hauser  NAR300	Endress+Hauser  NRR261	Endress+Hauser  NRR261
Order code: <u>1</u>	Order code: <u>1</u>	Order code: <u>1</u>
Ser. no.: <u>2</u>	Ser. no.: <u>2</u>	Ser. no.: <u>2</u>
漏油検出器 (Order code 参照) 防爆性能 Ex ia[ia Ga] IIB T4 Gb 本安回路(電源回路): $U_i = 28\text{ V}$, $I_i = 93\text{ mA}$, $P_i = 0.65\text{ W}$, $L_i = 48\text{ }\mu\text{H}$, C_i : 無視できる値 本安回路 2: $U_o = 13\text{ V}$, $I_o = 38\text{ mA}$, $P_o = 123.5\text{ mW}$, $L_o = 80\text{ mH}$, $C_o = 0.25\text{ }\mu\text{F}$ 周囲温度: $-20 \sim +60^\circ\text{C}$ 被測定物温度: $-20 \sim +60^\circ\text{C}$ エンドレスハウザー山梨株式会社 Made in Japan NP-2766	変換器 / Converter: 防爆型式 / Ex model(Order code 参照/Refer to Order code) 防爆性能 / Protection class : $\text{Ex db ia[ia Ga] IIB T4 Gb}$ 非本安回路 / Non intrinsic safety circuit: 電源 / Supply : <u>3</u> 許容電圧 / Um: AC 250 V 50/60 Hz, DC 250 V 周囲温度 / Ambient temperature : $-20 \sim +60^\circ\text{C}$ 被測定物温度 / Medium temperature: $-20 \sim +60^\circ\text{C}$ 製造日/Manufacturing date: <u>4</u> 注意: ・機器内部の部品及び配線の変更、改造等を行わないでください。 ・許容温度 70°C 以上のケーブルを使用してください。 ・通電中は容器の蓋を開けないでください。 ・防爆注意事項説明書(XA01840G)を参照して下さい。 警告: 容器の開放は、電源遮断後10分以上経過してから行って下さい。 Caution: ・Do not modify internal parts or circuits. ・Use supply wires suitable for 70°C minimum. ・Do not open the cover when energized. ・Refer to Ex-instruction manual (XA01840G). $\triangle \rightarrow \square$ WARNING: AFTER DE-ENERGIZING, DELAY 10 MINUTES BEFORE OPENING. IP67 エンドレスハウザー山梨株式会社 Endress+Hauser Yamanashi Co.,Ltd. Yamamashi 406-0846 Made in Japan NP-2768	変換器 / Converter 防爆型式 / Ex model(Order code 参照/Refer to Order code) 防爆性能 / Protection class : Ex db [ia Gb] IIB T6 Gb 本安回路 / Intrinsically safe circuit $U_o = 28\text{ V}$ $I_o = 85\text{ mA}$ $P_o = 595\text{ mW}$ $C_o = 0.083\text{ }\mu\text{F}$ $L_o = 2.4\text{ mH}$ 非本安回路 / Non Intrinsically safe circuit 電源 : <u>3</u> Power supply: 許容電圧: AC 250 V 50/60 Hz, DC 250 V Maximum voltage(Um): 周囲温度 / Ambient temperature $-20 \sim +60^\circ\text{C}$ 製造日/Manufacturing date: <u>4</u> 注意: ・機器内部の部品及び配線の変更、改造等を行わないでください。 ・許容温度 70°C 以上のケーブルを使用してください。 ・通電中は容器の蓋を開けないでください。 ・防爆注意事項説明書(XA01840G)を参照して下さい。 警告: 容器の開放は、電源遮断後10分以上経過してから行って下さい。 Caution: ・Do not modify internal parts or circuits. ・Use supply wires suitable for 70°C minimum. ・Do not open the cover when energized. ・Refer to Ex-instruction manual (XA01840G). $\triangle \rightarrow \square$ WARNING: AFTER DE-ENERGIZING, DELAY 10 MINUTES BEFORE OPENING. IP67 エンドレスハウザー山梨株式会社 Endress+Hauser Yamanashi Co.,Ltd. Yamamashi 406-0846 Made in Japan NP-2769
注意: ・機器内部の部品及び配線の変更、改造等を行わないで下さい。 ・許容温度 70°C 以上のケーブルを使用して下さい。 ・防爆注意事項説明書(XA01839G)を参照して下さい。 エンドレスハウザー山梨株式会社 IP67 Made in Japan NP-2767		

A0039865

 6 NAR300/NRR261 nameplates

- A NAR300 nameplate for JPN Ex
 B NRR261 nameplate for JPN Ex (NAR300 integrated type)
 C NRR261 nameplate for JPN Ex (NAR300 separate type)
 1 Order code
 2 Serial number
 3 Power supply voltage
 4 Manufacturing date

NRR262	Endress+Hauser 	
Order code	1	
Ser. no.	2	
変換器 / Converter : (Order Code 参照) / (Refer to Order Code)		
防爆性能 / Protection class : [Ex ia Gb] IIB Ta 60 °C		
本安回路 / Intrinsically safe circuit :		
U _o = 28 V, I _o = 85 mA, P _o = 595 mW, C _o = 0.083 μF, L _o = 2.4 mH		
非本安回路 / Non Intrinsically safe circuit :		
電源 / Power supply:	3	
許容電圧(U _m):	AC 250 V 50/60 Hz, DC 250 V	
周囲温度 / Ambient temperature :	-20 ~ +60 °C	
製造日/Manufacturing date:	4	
<p>注意: ・NRR262は、非危険場所に設置してください。</p> <ul style="list-style-type: none"> ・機器内部の部品及び配線の変更、改造等を行わないでください。 ・防爆注意事項説明書(XA01841)を参照してください。 <p>Note: ・NRR262 must be installed in non-hazardous area.</p> <ul style="list-style-type: none"> ・Do not modify internal parts or circuits.  →  ・Refer to Ex-instruction manual (XA01841G). 		
<p>エンドレスハウザー山梨株式会社 Endress+Hauser Yamanashi Co.,Ltd. Yamanashi 406-0846 Made in Japan</p>		IP20 NP - 2770

A0039866

7 NRR262 nameplate for JPN Ex

- 1 Order code
- 2 Serial number
- 3 Power supply voltage
- 4 Manufacturing date

4.3 Manufacturer address

Endress+Hauser Yamanashi Co., Ltd.
406-0846
862-1 Mitsukunugi, Sakaigawa-cho, Fuefuki-shi, Yamanashi

4.4 Storage and transport

4.4.1 Transport

NOTICE

The housing may become damaged or dislodged.

Risk of injury

- ▶ When transporting the device to the measuring point, either use the device's original packaging or hold by the process connector.
- ▶ Secure a hoisting device (such as a hoisting ring or a lifting eye bolt) to the process connector, not to the housing. Pay attention to the device's center of gravity to prevent unexpected tilting.
- ▶ Comply with the safety precautions and transportation conditions for devices that weigh 18 kg (39.6 lbs) or more (IEC61010).

5 Installation

5.1 Mounting NAR300 system

5.1.1 Handling precautions

When transporting NAR300, be sure to hold the float with both hands. Avoid holding the parts shown in the diagram below, and do not lift by the top of the float sensor. In addition, do not rotate the housing. Doing so may cause the device to malfunction.

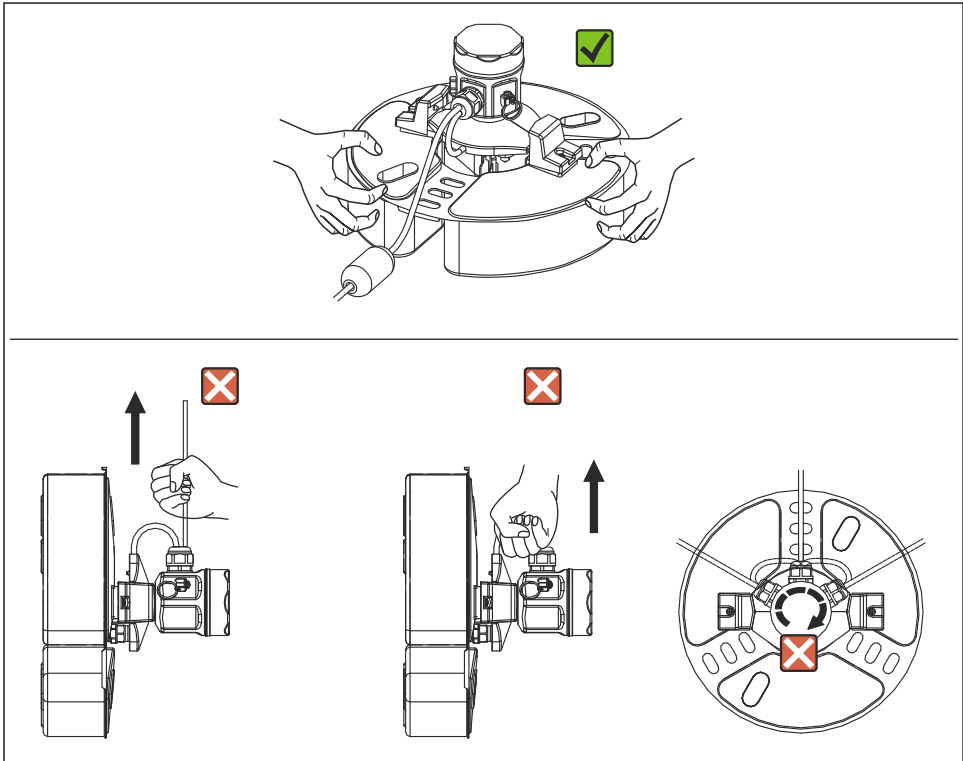

A0039878

8 Handling NAR300

5.1.2 Mounting the float guide

NAR300 can be mounted onto a float guide that has been installed for existing products (CFD10, CFD30, UFD10, NAR291, NAR292).

The float guide is 2 000 mm (78.74 in) in size. If a length shorter than 2 000 mm (78.74 in) is required for use, cut it to size. If a float guide longer than 2 000 mm (78.74 in) is required, contact your Endress+Hauser Sales Center.

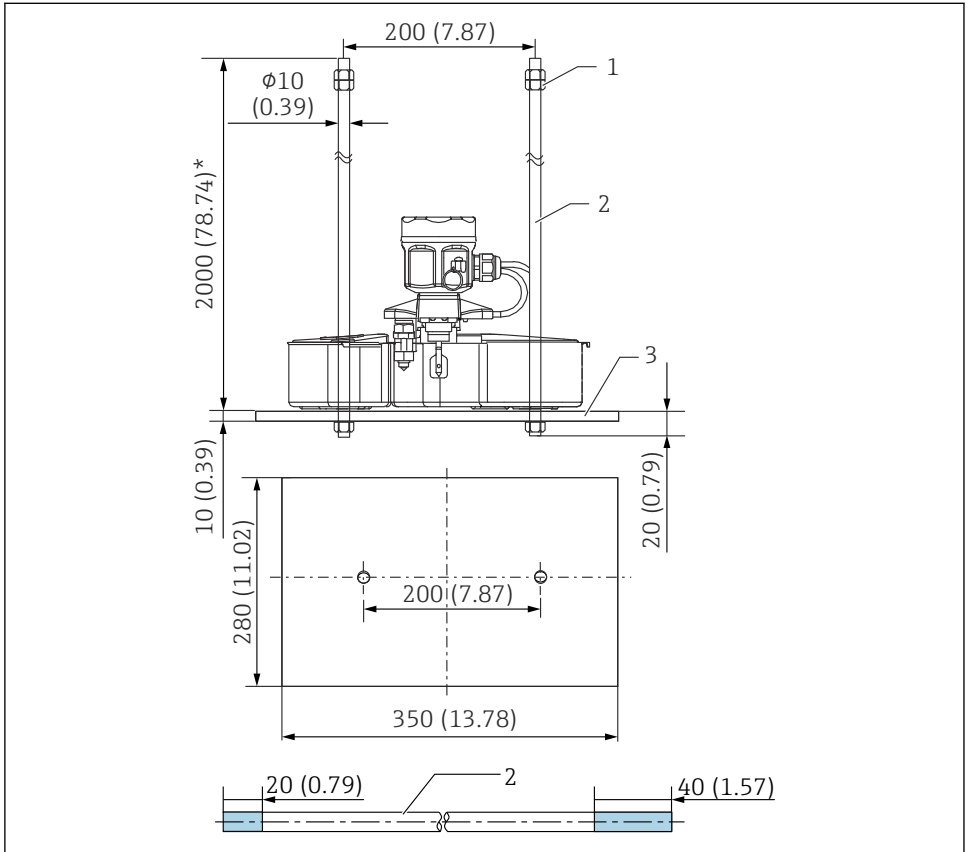

A0039879

9 NAR300, float guide. Unit of measurement mm (in)

- 1 Nut (M10)
- 2 Float guide
- 3 Weight

i The 20 mm (0.73 in) and 40 mm (1.57 in) of the float guide in the diagram indicate the lengths of screw thread grooves.

5.1.3 NRR261-4xx (integrated type) cable mounting

Mounting procedure

1. Remove the intrinsically safe terminal box cover [5] and the circuit board guard [4].
2. Pass the float sensor cable [2] through the cable gland [1] and the cable entry of the intrinsically safe terminal box.
3. Connect the cable to the terminal block (refer to "Electrical connection").
4. Tighten the main unit of the cable gland and the seal nut.
 - ↳ Tightening torque (main unit, seal nut): Approx. 1.96 N·m (20 kgf ·cm)
5. Secure the cable in place with the cable holder [3].
6. Attach the circuit board guard and close the cover of the intrinsically safe terminal box.

This completes the mounting procedure.

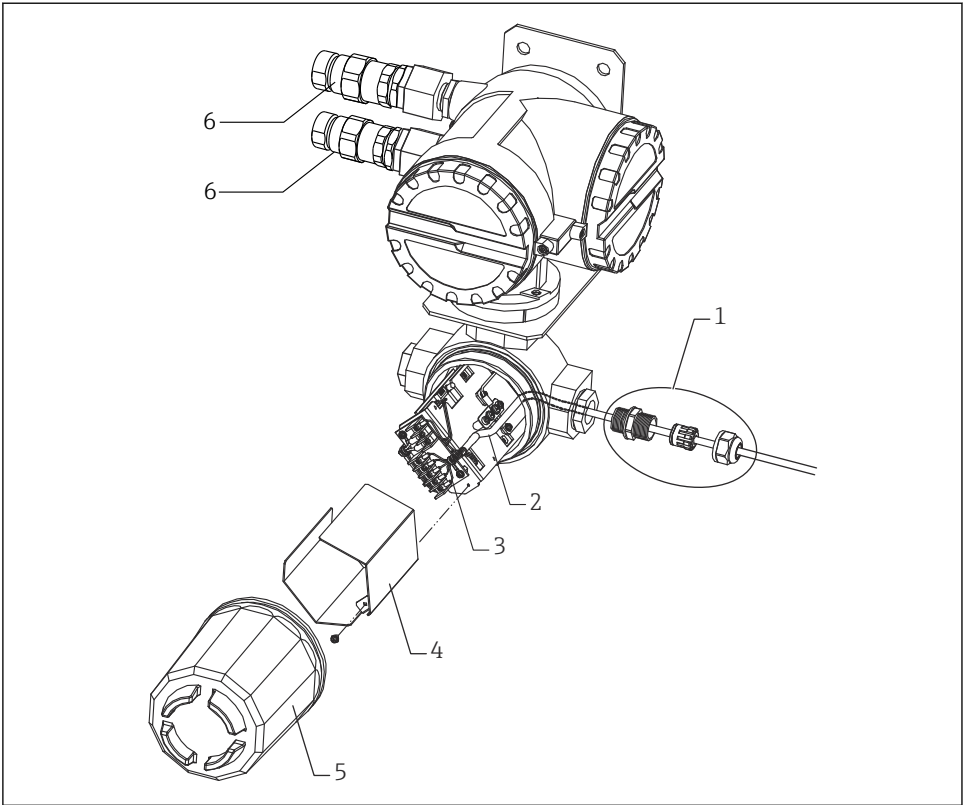

A0039881

10 NRR261-4xx cable mounting

- 1 Cable gland (waterproof connection)
- 2 Float sensor cable
- 3 Cable holder
- 4 Circuit board guard
- 5 Intrinsically safe terminal box cover
- 6 Cable gland (Ex d) (supplied with JPN Ex specifications only)



Since the cable gland [1] shown in the diagram is not supplied with products that do not have JPN Ex specifications, a water-proof cable gland that is IP67 or higher must be procured separately.

5.1.4 Mounting NAR300-x5xxxx and sensor I/F Ex box

Mounting procedure

1. Remove the intrinsically safe terminal box cover [5] and the circuit board guard [4].
2. Pass the float sensor cable [2] through the cable gland [1] and the cable entry of the intrinsically safe terminal box.
3. Connect the cable to the terminal block (refer to "Electrical connection").
4. Tighten the main unit of the cable gland [1] and the seal nut.
 - ↳ Tightening torque (main unit, seal nut): Approx. 1.96 N·m (20 kgf ·cm)
5. Pass the NRR262/NRR261 connecting cable through the cable entry of the terminal box, and connect it to the terminal block.
6. Secure the cable in place with the cable holder [3].
7. Attach the circuit board guard and close the cover of the intrinsically safe terminal box.

This completes the mounting procedure.

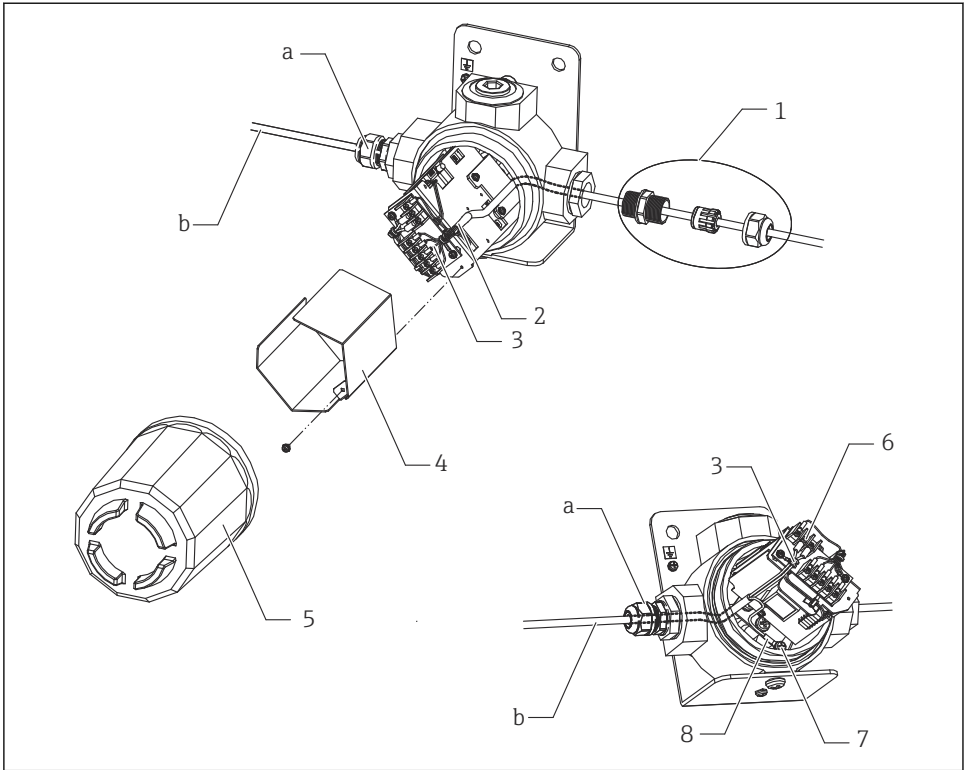

A0039882

11 NAR300-x5xxxx and sensor I/F Ex box cable mounting

- a Cable gland*
- b Shielded cable for NRR261/262 (must be procured separately)*
- 1 Cable gland (waterproof connection)*
- 2 Float sensor cable*
- 3 Cable holder*
- 4 Circuit board guard*
- 5 Intrinsically safe terminal box cover*
- 6 Screw (M3) for shielded cable*
- 7 Screw (M5)*
- 8 Shielded cable gland*

i Since the cable gland [a] shown in the diagram is not supplied with products that do not have JPN Ex specifications, a water-proof cable gland that is IP67 or higher must be procured separately.

5.1.5 NRR261-5xx cable mounting

Mounting procedure

1. Remove the intrinsically safe terminal box cover [4] and the terminal block cover [3].
2. Pass the float sensor cable [2] through the cable gland [1] and the cable entry of the intrinsically safe terminal box.
3. Connect the cable to the terminal block (refer to "Electrical connection").
4. Mount the cable gland [1] according to the operating instructions.
5. Secure the cable in place with the cable holder.
6. Attach the terminal block cover and close the cover of the intrinsically safe terminal box.

This completes the mounting procedure.

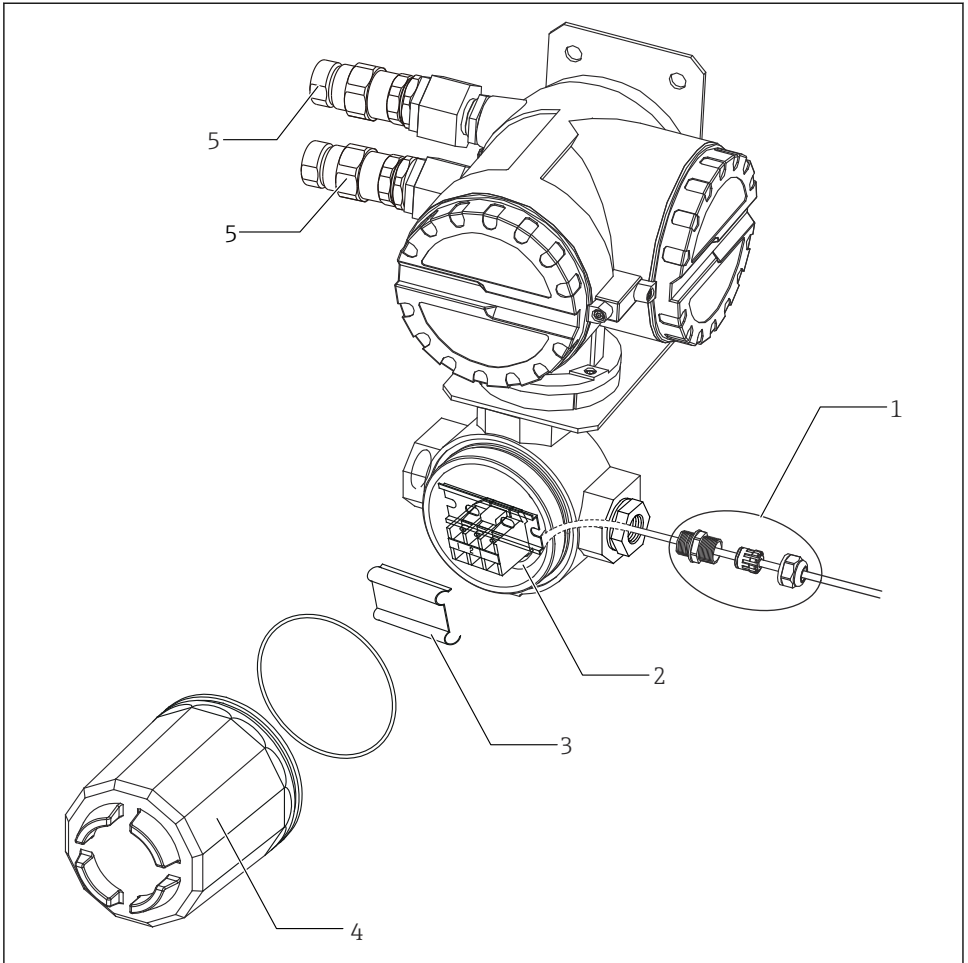

A0039883

12 NRR261-5xx cable mounting

- 1 Cable gland (waterproof connection)
- 2 Float sensor cable
- 3 Terminal block cover
- 4 Intrinsically safe terminal box cover
- 5 Cable gland (Ex d) (supplied with JPN Ex specifications only)



Since the cable gland [1] shown in the diagram is not supplied with products that do not have JPN Ex specifications, a water-proof cable gland that is IP67 or higher must be procured separately.

5.2 Adjustment

5.2.1 Verification of detection sensitivity with actual liquid

Verification of detection sensitivity with water in the bottom layer and oil in the top layer

When the tip of an electrode is pulled out from the water in the bottom layer, water may cling to the electrode tip like an icicle even when it is in the oil layer due to increased thickness of the oil layer, and this will increase the detection sensitivity by 1 to 2 mm. If accurate sensitivity verification is required, apply a small amount of neutral detergent to the electrode tip to improve water release.

Verification of oil layer thickness with a transparent container

Be cautious as liquid surface tension and adhesion of liquid onto the container wall may cause a reading error.

5.2.2 Adjustment of alarm output

Only the delay operation time (ON delay) setting of the alarm output relay can be adjusted on the converter. Time can be set using the delay trimmer. In NRR261, the delay trimmer can be found by turning off the power supply and opening the main unit's cover. In NRR262, the delay trimmer is found on the case surface. Match the setting to the necessary delay time in units of seconds. Delay operation is used to prevent false alarms by activating the alarm when an alarm state persists continuously over a certain period of time and not activating the alarm for operation that occurs within the set delay time. This can be set up to a maximum of 15 seconds for SIL specifications.

-  The response delay time of approximately 6 seconds on the detection circuit is always added to the delay time of the delay trimmer.
- When opening the main unit cover of NRR261, ensure that at least 10 minutes have passed after the power supply was cut.

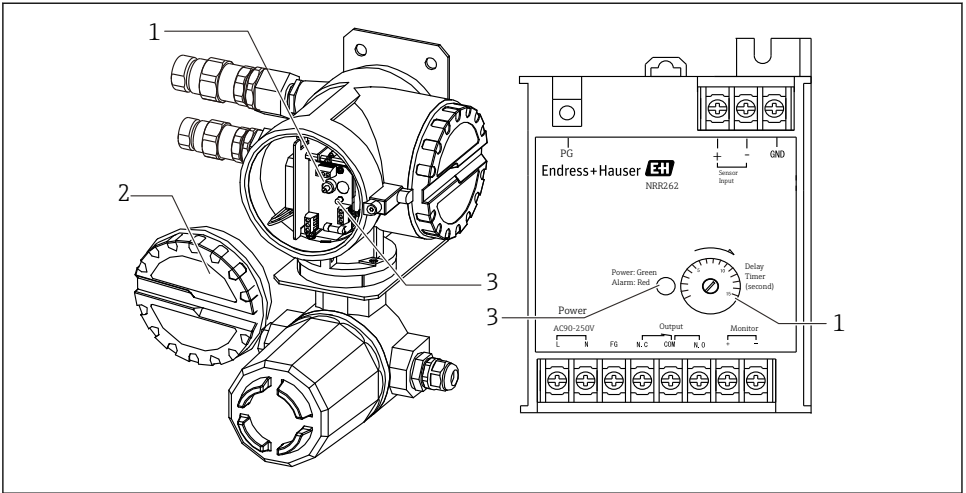

A0039891

13 Alarm output relay

- 1 Delay trimmer
- 2 Cover
- 3 LED power (green) / alarm (red)

6 Electrical connection

6.1 NRR261-4/A/B/C wiring

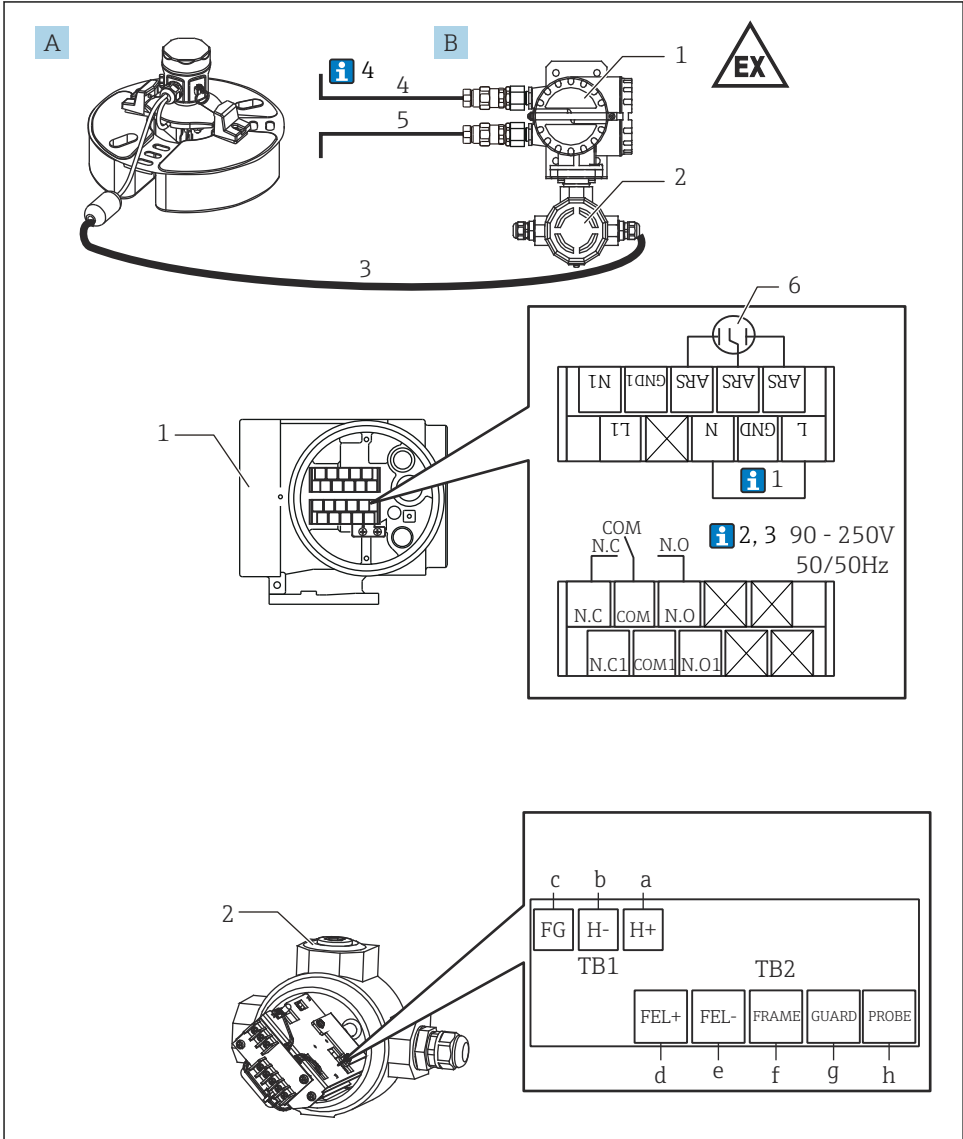

A0039887

14 Wiring of Ex d [ia] converter NRR261-4/A/B/C

- A *Float sensor NAR300-x1xxxx*
- B *Ex d [ia] converter NRR261 (integrated type)*
- a *Blue 1 (already wired upon delivery), screw (M3)*
- b *Blue 2 (already wired upon delivery), screw (M3)*
- c *Green, screw (M3)*
- d *Red, screw (M3)*
- e *Blue 3, screw (M3)*
- f *Yellow, screw (M3)*
- g *Black, screw (M3)*
- h *White, screw (M3)*
- 1 *Ex d terminal*
- 2 *Ex [ia] terminal*
- 3 *Using an Ex [ia]-dedicated connection cable (6 to 30 m (19.69 to 98.43 ft): included with the product depending on the option code)*
- 4 *Power supply: AC/DC*
- 5 *Alarm output: Alarm/PLC/DCS, etc.*
- 6 *Power supply arrester (installed)*



Below, the numbers correspond to the description in the diagram.

1. GND between "L" and "N" of NRR261 is connected when an AC cable with FG is used.
2. When using 22 to 26 V_{DC} power supply, the terminal number "L" becomes positive (+) and "N" becomes negative (-).
3. To maintain the Ex [ia] performance, ensure that the power supply voltage does not exceed 250 V_{AC}50/60 Hz during normal times and 250 V_{DC} during emergencies.
4. Cable (3) which connects NAR300 and NRR261 is included with NAR300. Alarm output cable (4) from NRR261 and power supply cable (5) to NRR261 are not included and must be procured by the customer. For more details on connection cables, refer to "Process conditions."

6.2 NRR262-4/A/B/C wiring

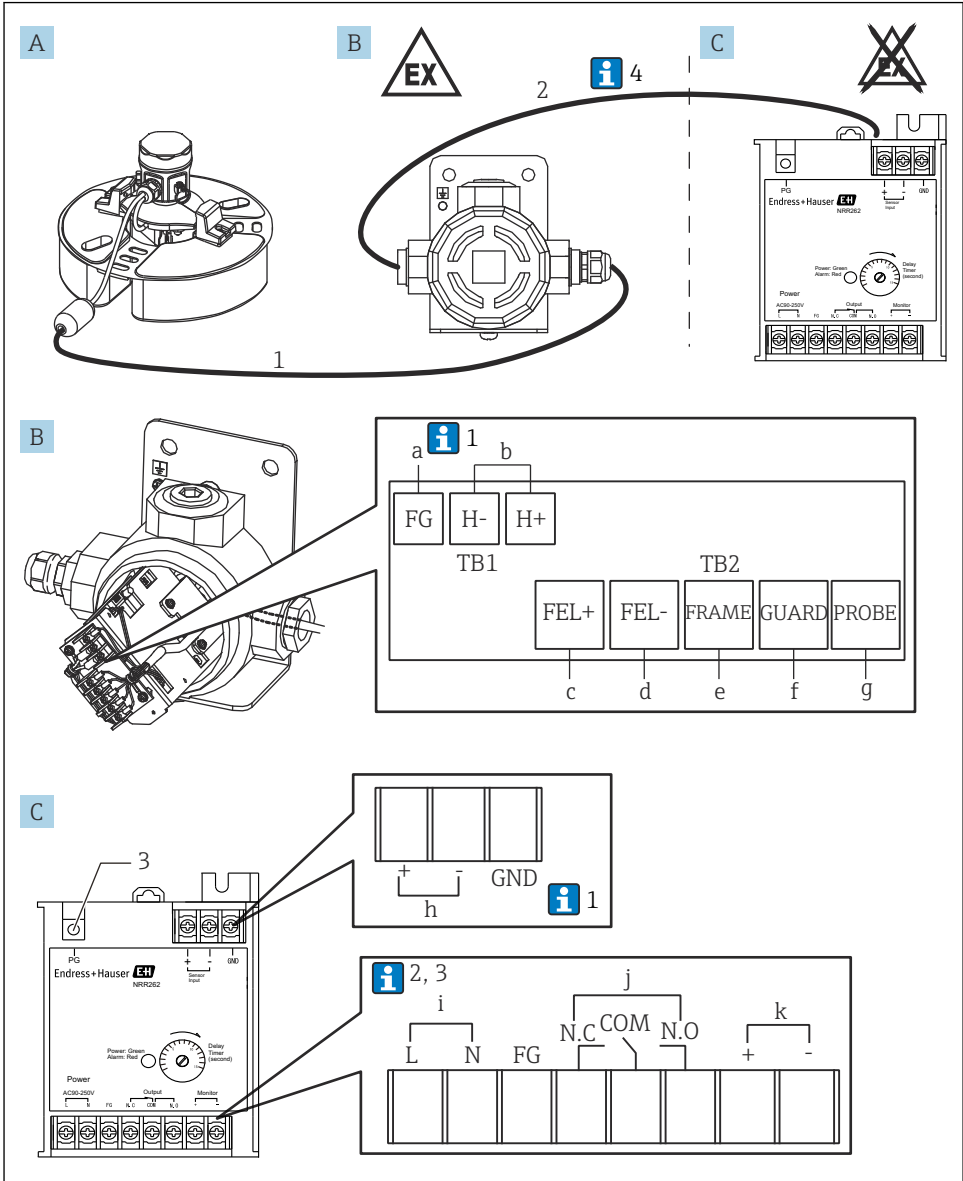

A0039688

15 Wiring of Ex [ia] converter NRR262-4/A/B/C

- A *Float sensor NAR300-x5xxxx (sensor I/F Ex box is also included in the code)*
- B *Sensor I/F Ex box*
- C *Ex [ia] converter NRR262*
- a *Green, screw (M3) (see Note 1 below)*
- b *Output to NRR262, screw (M3)*
- c *Red, screw (M3)*
- d *Blue, screw (M3)*
- e *Yellow, screw (M3)*
- f *Black, screw (M3)*
- g *White, screw (M3)*
- h *Input from sensor I/F Ex box, screw (M3)*
- i *Power supply: AC/DC, screw (M3)*
- j *Alarm output, screw (M3)*
- k *Checking monitor output, screw (M3)*
- 1 *Using an Ex [ia]-dedicated connection cable (6 to 30 m (19.69 to 98.43 ft): included with the product depending on the option code)*
- 2 *Cable for sensor I/F Ex box and NRR262 (to be prepared by the customer)*
- 3 *For protective grounding, screw (M4)*



Below, the numbers correspond to the description in the diagram.

1. Normally, only the FG of a sensor I/F Ex box is connected to the cable's shielded wire; however, depending on the installation environment, either the GND of NRR262 alone or both the FG of the sensor I/F Ex box and the GND of NRR262 are connected.
2. When using 22 to 26 V_{DC} power supply, the terminal number "L" becomes positive (+) and "N" becomes negative (-).
3. To maintain the Ex [ia] performance, ensure that the power supply voltage does not exceed 250 V_{AC} 50/60 Hz during normal times and 250 V_{DC} during emergencies.
4. While cable (1) for connecting NAR300 and sensor I/F Ex box is included with the device, cable (2) for connecting sensor I/F Ex box and NRR262 is not included with the device and must be procured by the customer. For more details on connection cables, refer to "Process conditions."

6.3 NRR261-5 wiring

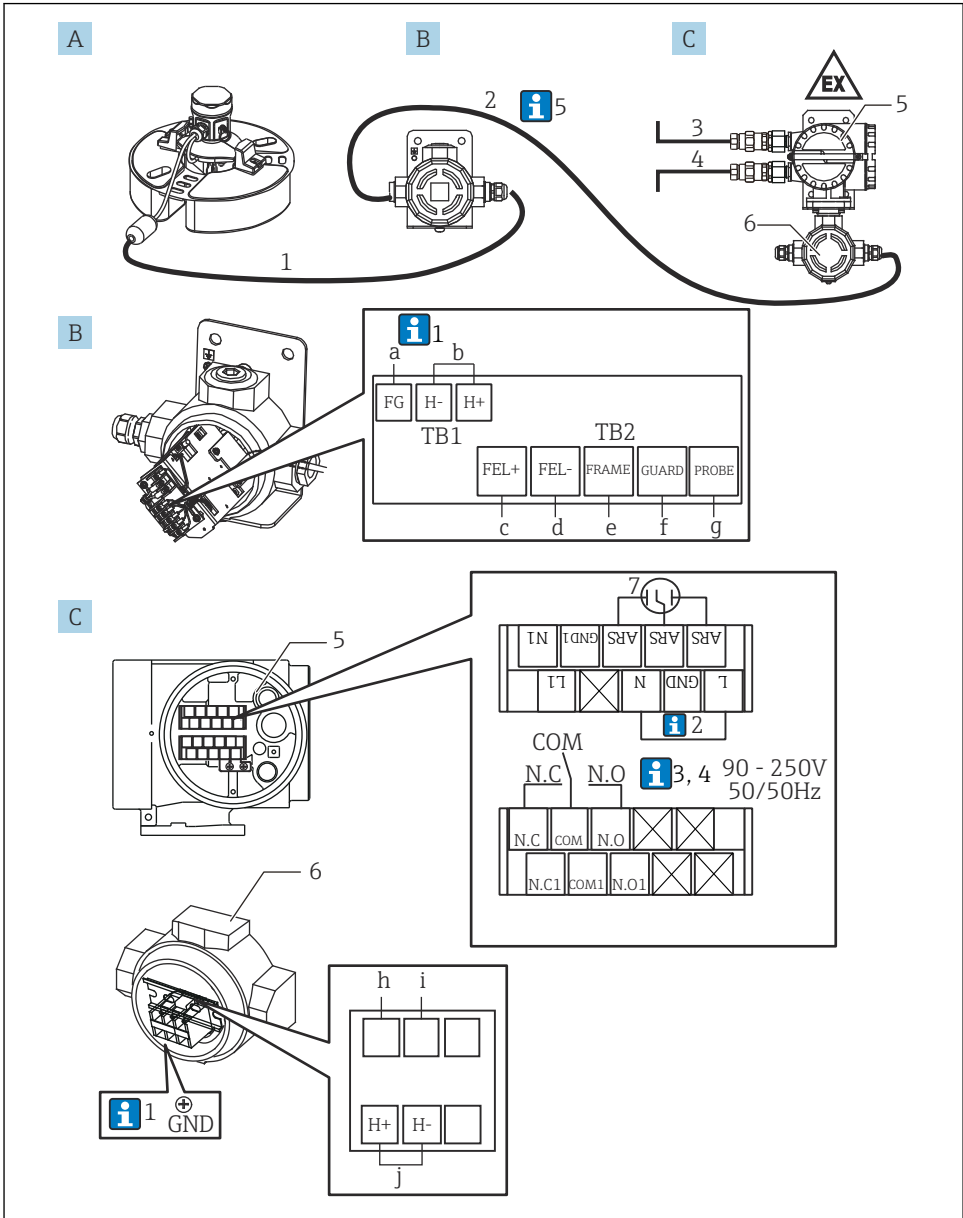

A0039889

16 Wiring of Ex d [ia] converter NRR261-5

- A Float sensor NAR300-x5xxxx (sensor I/F Ex box is also included in the code)
- B Sensor I/F Ex box
- C Ex d [ia] converter NRR261 (separate type)
- a Green, screw (M3) (see Note 1 below)
- b Output to NRR261-3/5xx, screw (M3)
- c Red, screw (M3)
- d Blue 1, screw (M3)
- e Yellow, screw (M3)
- f Black, screw (M3)
- g White, screw (M3)
- h Blue 2, screw (M4) (already wired upon delivery)
- i Blue 3, screw (M4) (already wired upon delivery)
- j Input from sensor I/F Ex box, screw (M4)
- 1 Using an Ex [ia]-dedicated connection cable (6 to 30 m (19.69 to 98.43 ft): included with the product depending on the option code)
- 2 Cable for sensor I/F Ex box and NRR261 (to be prepared by the customer)
- 3 Power supply: AC/DC
- 4 Alarm output: Alarm/PLC/DCS, etc.
- 5 Ex d terminal
- 6 Intrinsically safe terminal
- 7 Power supply arrester (installed), screw (M3)



Below, the numbers correspond to the description in the diagram.

1. Normally, only the FG of a sensor I/F Ex box is connected to the cable's shielded wire; however, depending on the installation environment, either the GND of NRR262 alone or both the FG of the sensor I/F Ex box and the GND of NRR262 are connected.
2. GND between "L" and "N" of NRR261 is connected when an AC cable with FG is used.
3. When using 22 to 26 V_{DC} power supply, the terminal number "L" becomes positive (+) and "N" becomes negative (-).
4. To maintain the Ex [ia] performance, ensure that the power supply voltage does not exceed 250 V_{AC} 50/60 Hz during normal times and 250 V_{DC} during emergencies.
5. Cable (1) which connects NAR300 and sensor I/F Ex box is included with NAR300. Cable (2) which connects sensor I/F Ex box and NRR262, alarm out cable (3) from NRR261, and power supply cable (4) for NRR261 are not included and must be procured by the customer. For more details on connection cables, refer to "Process conditions."

6.4 Wiring diagram

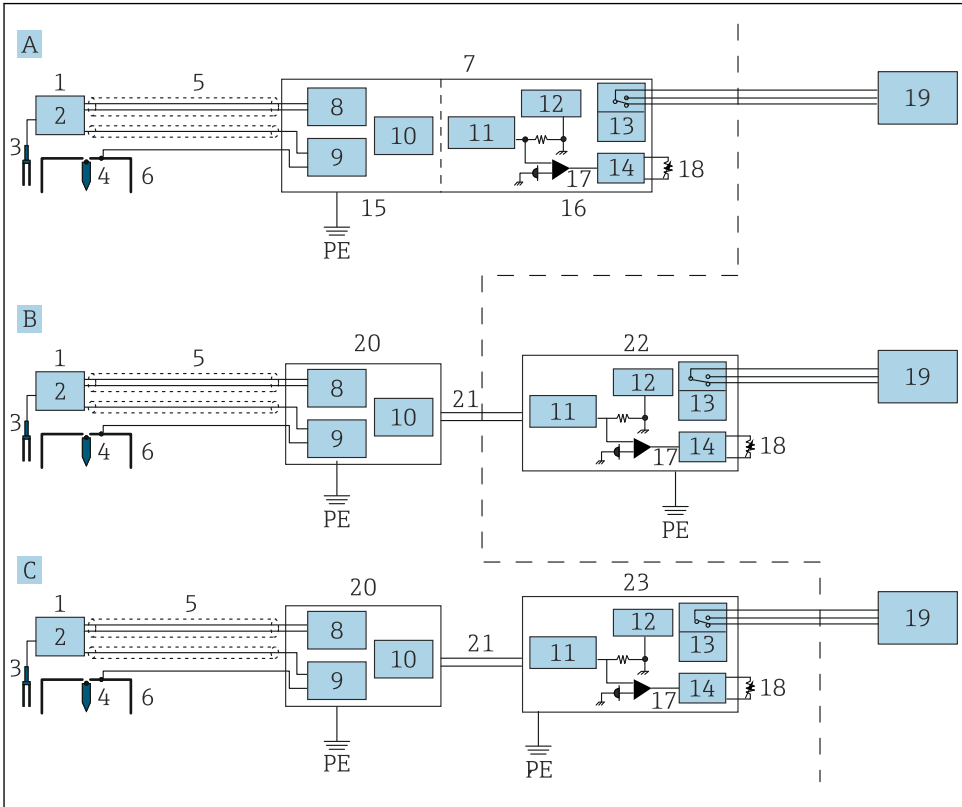

A0039890

17 Wiring diagram

A Explosion proof-type converter system (integrated type)

B Intrinsically safe converter system (separate type)

C Intrinsically safe, explosion proof-type converter (separate type)

PE Protective earth (protective grounding)

1 Float sensor NAR300

2 Tuning fork drive unit

3 Tuning fork

4 Conductivity detection electrode (sensor)

5 Dedicated cable

6 Conductivity detection electrode (float)

7 Converter NRR261 (integrated type)

8 Liquid detection circuit

9 Conductivity detection circuit

10 Current output circuit

11 Safety barrier

12 Power supply circuit

- 13 *Relay*
- 14 *Delay circuit*
- 15 *Ex [ia] circuit*
- 16 *Ex d circuit*
- 17 *Current detection*
- 18 *Delay trimmer*
- 19 *Alarm*
- 20 *Sensor I/F Ex box*
- 21 *Current signal*
- 22 *Converter NRR262*
- 23 *Converter NRR261 (separate type)*

6.5 Alarm activation principle

An oil leak detection signal detected by NAR300 float sensor is converted into a current signal inside the converter or sensor I/F Ex box. The signal is then connected to the current detection circuit through the intrinsically safe safety barrier inside the converter. In the current detection circuit, the presence or absence of an oil leak alarm signal is determined based on the size of current value, and the alarm out relay is turned ON/OFF through the operation delay circuit. The alarm delay circuit is equipped with a trimmer that can be used to set the delay time. Fail-safe operation is also available for relay contact point output, which is explained in the following "Alarm output operation table."

Alarm output operation table

NRR261/NRR262 terminals		Between NC and COM	Between NO and COM
State	Non-alarm	Open contact point	Closed contact point
	Oil leak alarm	Closed contact point	Open contact point
	Power OFF		
	Frozen liquid		

NAR300 current value	
Non-alarm	12 mA
Oil leak alarm	16 mA
Other trouble	< 10 mA or 14 mA <



71663997

www.addresses.endress.com
